



Standard Test Methods for Structural Panels in Planar Shear (Rolling Shear)¹

This standard is issued under the fixed designation D 2718; the number immediately following the designation indicates the year of original adoption or, in the case of revision, the year of last revision. A number in parentheses indicates the year of last reapproval. A superscript epsilon (ϵ) indicates an editorial change since the last revision or reapproval.

1. Scope

1.1 These test methods determine the shear properties of structural panels associated with shear distortion of the planes parallel to the edge planes of the panels. Both shear strength and modulus of rigidity may be determined. Primarily, the tests measure the planar shear (rolling shear) strength developed in the plane of the panel.

1.2 Structural panels in use include plywood, waferboard, oriented strand board, and composites of veneer and of wood-based layers.

1.3 Two test methods are included:

1.3.1 *Test Method A*—Planar shear loaded by plates.

1.3.2 *Test Method B*—Planar shear induced by five-point bending.

1.3.3 The choice of method will be dictated by the purpose of the test and equipment available.

1.3.4 *Test Method A, Planar Shear Loaded by Plates*—This test method uses a rectangular panel section adhered between steel plates with protruding knife edges to create load at the panel faces. This test method has been used to develop shear properties of plywood and oriented strand board for the purpose of confirming design values. This test method does not produce pure shear, but the specimen length is prescribed so that the secondary stresses have a minimum effect. The method determines shear strength and modulus of rigidity.

1.3.5 *Test Method B, Planar Shear Induced by Five-Point Bending*—Planar shear stress is induced on the panel while loaded in bending using two continuous spans. This test method determines planar shear strength consistent with panel applications under transverse loading. This test method is able to determine shear strength at any moisture condition.

1.4 *This standard does not purport to address all of the safety concerns, if any, associated with its use. It is the responsibility of the user of this standard to establish appropriate safety and health practices and determine the applicability of regulatory limitations prior to use.*

2. Referenced Documents

2.1 ASTM Standards:

D 2395 Test Methods for Specific Gravity of Wood and

¹ This test method is under the jurisdiction of ASTM Committee D-7 on Wood and is the direct responsibility of Subcommittee D07.03 on Panel Products.

Current edition approved June 10, 2000. Published August 2000. Originally published as D 2718 – 69 T. Last previous edition D 2718 – 95.

Wood-Based Materials²

D 4442 Test Methods for Direct Moisture Content Measurement of Wood and Wood-Base Materials²

3. Significance and Use

3.1 Planar shear (rolling shear) characteristics of structural panels determined by these test methods are essential for the rigorous design of various glued wood-panel structural components, such as box beams, folded plate roofs, and stressed skin panels. Planar shear also may govern the design at low span-depth ratios encountered in floors subjected to high concentrated loads, concrete forms at high pouring pressures, and bulk storage structures.

3.2 The modulus of rigidity determined from Test Method A is a composite of the entire specimen acting as a unit. For plywood panels for which the ratio between the shear moduli of the plies with grain oriented parallel and perpendicular to the shear forces is known, the rolling shear modulus of the perpendicular plies can be calculated.

3.3 Veneer produced by slicing or rotary peeling may contain fine checks or separations parallel to the grain on the knife side of the veneer that are produced as the knife is forced through the wood. These checks are termed “knife checks” to distinguish them from occasional checks that may be formed on the opposite side of the veneer by forces at the compression bar, and from checks caused by drying. Knife checks can have a significant effect on rolling shear properties in plywood panels and may be of significance in other veneer containing panels. Test Method A requires (when applicable) the testing of matching specimens having knife checks oriented both open and closed wherever possible (see Fig. 1).

3.4 To control or define other variables influencing rolling shear, these test methods require determination of moisture content, specific gravity, and elapsed time-to-failure. Conditioning of test material in controlled atmospheres, determination of depth of knife checks (when applicable), and determination of percent of wood and plywood glue-line failure (when applicable) are recommended.

4. Control of Moisture Content

4.1 The structural panel samples to be tested at specific moisture contents or equilibrium relative humidities shall be conditioned to approximately constant weight in controlled

² *Annual Book of ASTM Standards*, Vol 04.10.

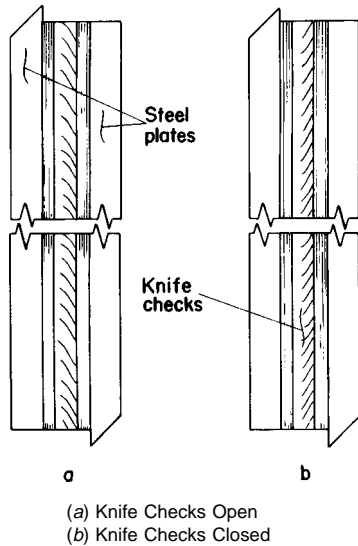

FIG. 1 Orientation of Knife Checks in Plywood

atmospheric conditions before gluing to plates. For approximating moisture conditions of structural panel used under dry conditions a relative humidity of $65 \pm 2\%$ at a temperature of $68 \pm 6^\circ\text{F}$ ($20 \pm 3^\circ\text{C}$) is recommended. Specimens shall be tested without undue delay after the adhesive is cured. Testing in similarly controlled atmospheres is recommended wherever possible.

Test Method A—Planar Shear Loaded by Plates

5. Scope

5.1 The specimen having the form of a rectangular flat plate is bonded between steel plates beveled at opposite ends of the specimen to provide knife edges for loading the plate at the face bonded to the specimen. The knife edges project beyond the ends of the specimen. This test method is conducted by loading the knife edges in compression at a uniform rate while a suitable gage measures slip between the plates due to specimen deformation. Shear strength is computed from maximum load, and effective shear modulus for the specimen is determined from a plot of load versus slip.

6. Test Specimen

6.1 Specimen thickness shall be that of the material. Specimens from material that is expected to vary significantly within the specimen due to growth or manufacturing features or from other causes shall be 6 in. (15 cm) wide by 18 in. (45 cm) long or larger as shown in Fig. 2. This size is recommended for uniform material as well. However, smaller specimens of uniform material may be used if these are not less than four times the thickness in width nor twelve times the thickness in length.

6.2 From each sample of panels containing veneer, two matching specimens shall be cut. Knife edges of loading plates for one specimen of each matching pair shall be oriented perpendicular to one of the primary panel directions or for plywood to cause opening of knife checks during test as shown in Fig. 1(a). Knife edges of plates loading the other specimen shall be positioned perpendicular to one of the primary panel

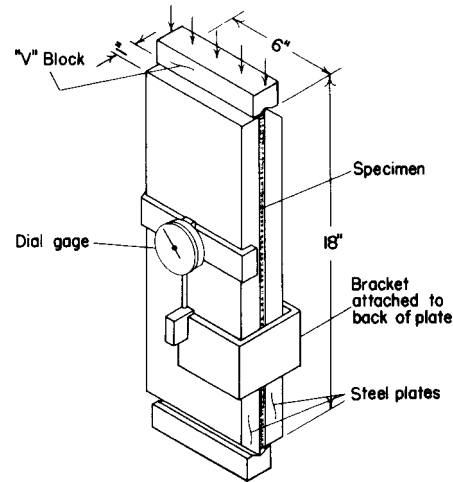

NOTE 1—The “V” block is supported on a seat that provides rotation about the axis perpendicular to the knife edge only.

Metric Equivalents		
in.	6	18
mm	15	45

FIG. 2 Planar (Rolling) Shear Test Using a Dial Gage for Measuring Plate Slip

directions or for plywood to cause knife checks to close during test as shown in Fig. 1(b). Proper plywood orientation may be determined from check depth specimens described in 16.3. It may not be possible to test samples having two or more plies stressed in rolling shear in both “open” and “closed” orientations if these plies are oriented in opposite directions causing a “checks open” failure regardless of direction of loading.

6.3 Specimen length and width shall be measured to the nearest 0.01 in. (0.25 mm) and thickness to the nearest 0.001 in. (0.025 mm). When applicable, the direction of knife checks in plies having grain perpendicular to its length shall be determined and the specimens marked for position of knife edges. At the time specimens are cut matching samples for determination of moisture content and specific gravity in accordance with 16.1 and 16.2 shall be obtained. When measurement of knife checks is included as discussed in 16.3, a sample for this measurement also may be cut at this time.

7. Loading

7.1 Figs. 1 and 2 illustrate the specimen and suitable loading plates and blocks for loading the knife edges of the plates. The specimen shall be loaded by steel plates bonded to both faces of the specimen with an adhesive sufficiently rigid to preclude contribution of adhesive creep to measured deformation. Width of plates shall be that of the specimen. One end of each plate shall be provided with a knife edge projecting 1/4 in. (6 mm) beyond the end of the specimen at one end and flush with the surface glued to the specimen. The other end of the plate shall be square and flush with the end of the specimen. Knife edges of the two plates shall be at opposite ends of the specimen and shall be oriented to load the specimen in the desired direction in relation to the knife checks. Planar shear properties of structural panels should be determined in both directions. Plates for specimens 18 in. (45 cm) long shall be 1 in. (2.5 cm) thick. The thickness of plates for shorter specimens may be

reduced proportionately. Loading of at least one V-block shall provide for uniform load distribution along the knife edge by loading through a pivot having its axis perpendicular to the knife edge and centered along it. Pivots permitting rotation about an axis parallel to the knife edge or spherical seats free to pivot in this manner shall not be used as they create unstable loading which may cause violent ejection of the specimen from the machine and hazard to operating personnel. The V-blocks shall be vertically positioned in the machine, one above the other, causing the forces applied to the specimen to act parallel to the axis of the machine. The specimen itself will be slightly inclined when placed in the machine. A means of holding the plates in an upright position after the specimen has sheared apart is desirable as a complete separation of the specimen permits the plates to be thrown out of the machine with attendant hazard to the operator.

7.2 Load shall be applied continuously throughout the test at constant rate of cross-head motion to normally produce failure in the range of 3 to 12 min elapsed time from beginning of loading. For plywood, the approximate speed may be determined as follows:

$$N = 0.0075 (\Sigma T_{\parallel} + R \Sigma T_{\perp}) \quad (1)$$

where:

- N = crosshead speed, in./min (cm/min),
- ΣT_{\parallel} = total thickness of plies having grain parallel to direction of shear force, in. (cm),
- R = 8 (assumed ratio of shear modulus of parallel plies to shear modulus of perpendicular plies), and
- ΣT_{\perp} = total thickness of plies having grain perpendicular to the direction of shear force, in. (cm).

7.2.1 Elapsed time from beginning of load application to failure of each specimen shall be measured and recorded to the nearest half minute. Machine speeds calculated by the above formula will normally produce failure in the range of 3 to 12 min elapsed time from the beginning of loading. Should elapsed time to failure fall greatly outside this range, machine speed should be modified to obtain times within this range.

7.3 Both epoxy and polyvinyl adhesives have been found satisfactory for bonding steel plates to specimens. Minimum required surface preparation of steel plates consists of removal of residual adhesive. This can be accomplished most easily by mild heating of the plate and any portion of the specimen remaining from the previous test in an oven which weakens the bond to the steel sufficiently to permit peeling the remaining wood and adhesive from the plate. The residual adhesive may be scraped off with a sharp-edged tool. Further degreasing and cleaning has frequently been found necessary in addition to the above to ensure adequate bond strength. Curing the adhesive at a slightly elevated temperature has also been helpful.

8. Measurement of Deformation

8.1 Slip between the steel plates during load application shall be measured to at least the nearest 0.0001 in. (0.002 mm) at no less than twelve and preferably more equally spaced increments of load to proportional limit from which a load-deformation curve shall be plotted. Slip can be measured with a dial gage as illustrated in Figs. 2 and 3 or with appropriate automatic measuring and recording equipment. Gage geometry

and position on the specimen shall be such as to minimize any effects of unsymmetrical loading or deformation.

9. Calculation

9.1 Shear stress shall be calculated as follows:

$$f_v = P/(L \cdot W) \quad (2)$$

where:

- f_v = shear stress, psi (N/mm),
- P = maximum or proportional limit load (force), lbf (N),
- W = specimen width, in. (mm), and
- L = specimen length, in. (mm).

Maximum shear stress obtained from specimens having final failure of the bond between the plate and the specimen shall be regarded as defective and shall be clearly indicated in the report of results.

9.2 Effective modulus of rigidity for the specimen acting as a unit shall be calculated as follows:

$$G = (P/\Delta)[t/(L \cdot W)] \quad (3)$$

where:

- G = apparent modulus of rigidity for the entire specimen, psi (N/mm),
- t = specimen thickness, in. (mm),
- P/Δ = slope of the force-deformation curve below proportional limit load, lbf/in. (N/mm), and other notation is as indicated in 9.1.

For plywood, modulus of rigidity of the cross plies may be calculated from that given above if the ratio of moduli of rigidity and thickness of the parallel and perpendicular plies is known.

Test Method B—Planar Shear Induced by Five-Point Bending

10. Scope

10.1 Specimens are tested in a two-span continuous beam support configuration with line loads applied at midspan of each span as shown in Fig. 4. Induced shear stresses are consistent with those developed in conventional panel applications under transverse loading. Specimens may be tested in any moisture condition.

11. Test Specimen

11.1 The test specimen shall be rectangular in cross-section. The depth of the specimen shall be the thickness of the material, and the width shall be at least 4.5 in. (115 mm) and no greater than 10 in. (255 mm) (see Note 1).

NOTE 1—Specimen width may be modified for practical purposes. Since shear strength may vary slightly with specimen width, specimen width shall be reported with shear strength results.

11.2 *Measurements*—Specimen thickness and width shall be measured to the nearest 0.001 in. (0.02 mm) at midlength (over center support) and at midspan (under line loads). Thickness measurements shall be determined at these locations on each side of each specimen for a total of six measurements per specimen.

12. Span

12.1 The test span shall be determined from the following



FIG. 3 Planar (Rolling) Shear Specimen Ready for Testing

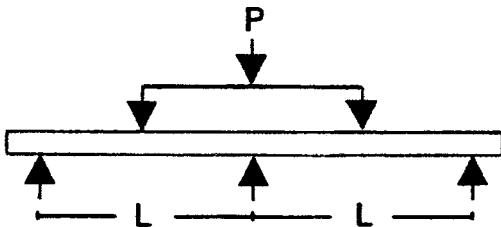

FIG. 4 Loading Configuration for the Five-Point Bending Method

equation if the average bending and shear stress estimates are available:

$$L = (11/12) d (f_b/f_v) > 11 d \quad (4)$$

where:

- L = test span (in.),
- d = specimen depth (in.),
- f_b = average bending stress (psi), and
- f_v = average shear stress (psi).

12.2 If the average bending and shear stress estimates are not available, the test span shall be at least 16 times the nominal specimen depth for the primary axis and 11 times the nominal specimen depth for the secondary strength axis.

NOTE 2—The test span may be adjusted for quality assurance purposes as long as all tests are conducted using the same test span. The test span determined from the preceding equation is particularly appropriate for quality assurance purposes, as fifty percent of the specimens will fail in

shear and the remaining fifty percent will fail in bending. Reducing the span from that determined from the same equation will increase the proportion of shear failures. Since the magnitude of shear stress will increase with decreasing span, it is recommended that test spans be maintained within 10 % of that determined from the preceding equation.

13. Supports and Loading Heads

13.1 Supports shall be rounded to minimize friction between the supports and test specimens. Supports shall be free to rotate laterally to compensate for specimen distortion. Loading heads shall be rounded with a radius of curvature comparable to that of the supports.

14. Speed of Testing

14.1 Load shall be applied at a constant rate in order to reach ultimate load within a 4 to 6 min time frame. A 0.05 in./min loading rate is recommended as an initial rate for the purpose of establishing an appropriate rate for tests of record.

14.1.1 *Data Collection*—Record time for testing each specimen, ultimate load, failure location, and failure mode (shear or bending).

15. Calculation

15.1 *Shear Stress*—Calculate induced shear stress as follows:

$$f_v = (33P)/(64bd) \quad (5)$$

where:

- f_v = induced shear stress (psi),
- P = ultimate test load (lbf),
- b = specimen width (in.), and
- d = specimen thickness (in.).

NOTE 3—The above formula for induced shear stress assumes a parabolic shear distribution with maximum stress at middepth of the specimen.

15.2 *Bending Stress*—Calculate induced bending stress as follows:

$$f_b = (9 PL)/(16 b d^2) \quad (6)$$

where:

- f_b = induced bending stress (psi),
- P = ultimate test load (lbf),
- L = test span (in.),
- b = specimen width (in.), and
- d = specimen thickness (in.).

NOTE 4—Calculation of induced stresses for bending and shear (regardless of failure mode) is useful for characterizing material resistance and adjusting test span as necessary to shift the proportion of shear failures.

16. Variables Influencing Planar Shear Properties

16.1 *Moisture Content*—When a 100 % reactive adhesive is used for plate bonding, a moisture content sample having a minimum area of 4 in.² (26 cm²) shall be cut from clear material matched to the test specimen and weighed at the time the specimen is glued to the plates. When an adhesive containing water is used for plate bonding, or when heat sufficient to cause a change in moisture content of the test specimen is used to cure the adhesive, the moisture content sample shall be cut from the actual test specimen after failure. When taken after failure, the moisture content sample shall be removed immediately from the ply which has failed and shall contain sufficient volume of material to be representative of the failed ply.

16.1.1 If inspection of the edges reveals the presence of a defect, select a second sample.

16.1.2 Moisture content shall be determined in accordance with Test Method D 4442.

16.2 *Specific Gravity*—Specific gravity determinations shall be made in accordance with Test Methods D 2395. The specimen may be the same as that for moisture content determination but in any case must be at least 2 in.³ (33 cm³) in volume, and be free of defects.

16.3 *Depth of Knife Checks*—For plywood and composites, it is recommended that average depth of knife checks in each ply with grain perpendicular to loads be determined as depth of knife checks has been found to influence rolling shear. Determination of check frequency is also suggested. When included, these measurements shall be an average of two 3-in. (7.5-cm) wide and separated by an intervening distance of 6 in. (15 cm). One pair of measurements shall be taken on material end-matched to each ply stressed in rolling shear. Results for each rolling shear ply shall be reported in terms of average depth, expressed as a percent of total thickness, and average number

of checks per inch (centimeter).

16.3.1 A recommended method of preparing knife check specimens of matching veneer obtained before the veneers are glued consists of first sealing the end grain with hot paraffin. After cooling, the specimens are dipped in alcohol-soluble dye that penetrates the knife checks from the surface of the specimen only. After the alcohol has evaporated, the sample is scarfed across the grain to present a magnified view of the thickness dimension and knife checks.

16.3.2 Plywood samples may be prepared by omitting the end sealing step in 16.3.1 and scarfing at a steeper slope. Dipping in the dye should be sufficiently prolonged to allow penetration of the exposed end grain of the veneers. Scarfing should not extend beyond the range of dye penetration of the knife checks.

16.4 *Plywood Wood Failure*—It is recommended that after testing, the two halves of the specimen be separated and the percent area of the failed surface occurring in the wood of the rolling shear ply and in the glue line between it and the adjacent plies be determined and reported. Low wood failure is indicative of poor bonds between plies which in turn may adversely affect the rolling shear strength determined by this test.

17. Report

17.1 The structural panel shall be described as to species, construction, and adhesive type used in its manufacture, as well as the bonding method used to attach the steel plates to the specimen. A much more complete description of specimen material may be appropriate in some instances. Data for individual specimens and specimen averages shall include:

- 17.1.1 Thickness,
- 17.1.2 Moisture content,
- 17.1.3 Specific gravity,
- 17.1.4 Maximum shear stress,
- 17.1.5 Modulus of rigidity,
- 17.1.6 Load-deflection diagrams,
- 17.1.7 Elapsed time to failure, and

17.1.8 Description of specimen failure. In specific cases it may be necessary or desirable to include such other data as maximum loads, modulus of rigidity of cross plies, grade and manufacturing characteristics which may influence results, depth of knife checks, and percent of wood failure.

17.2 The methods used to calculate moduli of rigidity, if any, of perpendicular plies shall be clearly stated including any assumptions as to ratios of properties between parallel and perpendicular plies.

18. Precision

18.1 The precision of this test method has not yet been determined, but when data are available a precision statement will be included.

19. Keywords

19.1 shear; shear distortion; shear properties; structural panels

 **D 2718**

The American Society for Testing and Materials takes no position respecting the validity of any patent rights asserted in connection with any item mentioned in this standard. Users of this standard are expressly advised that determination of the validity of any such patent rights, and the risk of infringement of such rights, are entirely their own responsibility.

This standard is subject to revision at any time by the responsible technical committee and must be reviewed every five years and if not revised, either reapproved or withdrawn. Your comments are invited either for revision of this standard or for additional standards and should be addressed to ASTM Headquarters. Your comments will receive careful consideration at a meeting of the responsible technical committee, which you may attend. If you feel that your comments have not received a fair hearing you should make your views known to the ASTM Committee on Standards, at the address shown below.

This standard is copyrighted by ASTM, 100 Barr Harbor Drive, PO Box C700, West Conshohocken, PA 19428-2959, United States. Individual reprints (single or multiple copies) of this standard may be obtained by contacting ASTM at the above address or at 610-832-9585 (phone), 610-832-9555 (fax), or service@astm.org (e-mail); or through the ASTM website (www.astm.org).