



Standard Test Methods for Wood-Based Structural Panels in Compression¹

This standard is issued under the fixed designation D 3501; the number immediately following the designation indicates the year of original adoption or, in the case of revision, the year of last revision. A number in parentheses indicates the year of last reapproval. A superscript epsilon (ϵ) indicates an editorial change since the last revision or reapproval.

This standard has been approved for use by agencies of the Department of Defense.

1. Scope

1.1 These test methods cover the determination of the compression properties of wood-based structural panels. Wood-based structural panels in use include plywood, waferboard, oriented strand board, and composites of veneer and of wood-based layers.

1.2 *Method A, Compression Test for Small Specimens*—This method is applicable to small specimens that are uniform with respect to elastic and strength properties. Two types of compression tests are employed: one to evaluate both elastic and compressive strength properties, and the second to evaluate maximum compressive strength only.

1.3 *Method B, Compression Test for Large Specimens*—This method employs large specimens and responds well to manufacturing variables and growth characteristics that influence compression properties of structural panels.

1.3.1 This method is intended for the following:

1.3.1.1 Comparative tests of structural panels,

1.3.1.2 Evaluating the effects of moisture content on strength properties of structural panels,

1.3.1.3 Determining the strength properties of structural panels, and

1.3.1.4 Evaluating the effects of raw material and manufacturing variables on compression properties of structural panels.

1.4 *This standard does not purport to address all of the safety concerns, if any, associated with its use. It is the responsibility of the user of this standard to establish appropriate safety and health practices and determine the applicability of regulatory limitations prior to use.*

2. Referenced Documents

2.1 *ASTM Standards:*

D 2395 Test Methods for Specific Gravity of Wood and Wood-Base Materials²

D 4442 Test Methods for Direct Moisture Content Measurement of Wood and Wood-Base Materials²

3. Significance and Use

3.1 These methods determine the compressive strength of

structural panels in response to stresses acting in the plane of the panel.

3.2 *Method A*—This method is applicable to structural panels of uniform properties within a panel. It is useful for evaluating plywood of clear, straight-grained veneers and determining the effect of chemical or preservative treatments, construction, principal direction with respect to direction of stress, and other variables that are expected to uniformly influence the panel.

3.3 *Method B:*

3.3.1 The compressive properties obtained by this method are a reliable approximation of the strength of a full-size panel, and are intended for use in design.

3.3.2 The compressive properties are influenced by buckling; however, this effect is eliminated in this test by restraining the edges of the specimens.

3.4 It is recommended that where comparisons are to be made, that the same method and specimen size be used throughout. This is because the volume of material included in a test specimen can influence the compressive strength regardless of whether the material properties are uniform throughout the sheet or vary widely due to the presence of growth or manufacturing features.

4. Control of Moisture Content

4.1 Condition structural panel samples to be tested at a specific moisture content or relative humidity to approximate constant weight in controlled atmospheric conditions before testing. For panels used under dry conditions, a relative humidity of $65 \pm 2\%$ at a temperature of $68 \pm 6^\circ\text{F}$ ($20 \pm 3^\circ\text{C}$) is preferred.

5. Variables Influencing the Compressive Properties of Structural Panels

5.1 *Moisture Content*—Cut a moisture content sample having minimum area of 2 in.² (13 cm²) from the clear areas of the specimen and weigh immediately after each test. Moisture content samples from large specimens of Method B shall have minimum area of 8 in.² (52 cm²). If inspection of the edges of a plywood panel reveals the presence of a knot in any ply, select a second sample. Moisture content samples also serving as specific gravity samples shall be free of voids. Moisture content determinations shall be made in accordance with Test Methods D 4442.

¹ These test methods are under the jurisdiction of ASTM Committee D-7 on Wood and are the direct responsibility of Subcommittee D07.03 on Panel Products. Current edition approved July 15, 1994. Published September 1994. Originally published as D 3501 – 76. Last previous edition D 3501 – 76(1986).

² *Annual Book of ASTM Standards*, Vol 04.10.

5.2 *Specific Gravity*—Determine specific gravity in accordance with Test Methods D 2395. The specimen may be the same as that for moisture content determination but must have volume of at least 1 in.³ (16 cm³) if from small specimens, and at least 3 in.³ (49 cm³) if from large specimens and be free of visible knots or voids.

METHOD A—COMPRESSION TEST FOR SMALL SPECIMENS

6. Direction of Grain, Fibers, or Layers

6.1 The direction of the individual plies, laminations, or layers shall be parallel, perpendicular, or inclined at any other required angle to the length of the test specimen.

7. Test Specimen

7.1 The test specimen shall be rectangular in cross section. The thickness, width, and length of each specimen shall be measured to an accuracy of not less than ±0.3 % or 0.001 in. (0.02 mm), whichever is larger.

7.2 When tests to evaluate both elastic and compressive strength properties are required, the size of the specimens shall be as follows:

7.2.1 *For Material Over ¼ in. (6 mm) in Thickness*, the specimens shall have a thickness equal to that of the material and the width shall be a minimum of 1 in. (25 mm) but not less than the thickness. The length shall be not greater than seven times the least cross-sectional dimension.

7.2.2 *For Material ¼ in. (6 mm) or Less in Thickness*, the specimen shall have the following dimensions: thickness equal to that of the material; the width nominally 1 in. (25 mm); and

length 4 in. (100 mm). Such specimens shall be supported laterally throughout the test.

7.2.3 When tests to evaluate maximum compressive strength only are required, an alternative type of specimen 4 in. (100 mm) in width and a length equal to six times the thickness may be used.

7.2.4 The end surfaces of the specimen shall be smooth and parallel to each other and at right angles to the length.

8. Evaluation of Both Compressive Strength and Elastic Properties

8.1 Support laterally test specimens ¼ in. (6 mm) or less in thickness intended for use in obtaining load deformation data to prevent buckling during the test, but do not exert undue pressure against the sides of the specimen. This support shall not measurably restrain the normal compressive deformation under load. A satisfactory method of providing lateral support is illustrated in Fig. 1, and a detailed design of this apparatus is shown in Fig. 2.

9. Loading Procedure

9.1 Apply the load through a spherical bearing block preferably of the suspended, self-aligning type. Apply the load with a continuous motion of the movable head so as to cause failure within 3 to 10 min after initiation of loading. A rate of 0.003 in./in. (mm/mm) of length of the specimen per minute within a permissible variation of ±25 % has usually proved satisfactory.

9.2 Measure the elapsed time from initiation of loading to maximum load and record to the nearest ½ min.



FIG. 1 Compression Test of Thin Structural Panel Supported Laterally Showing Marten's Mirror Compressometer for Measuring Deformations on Two Opposite Faces

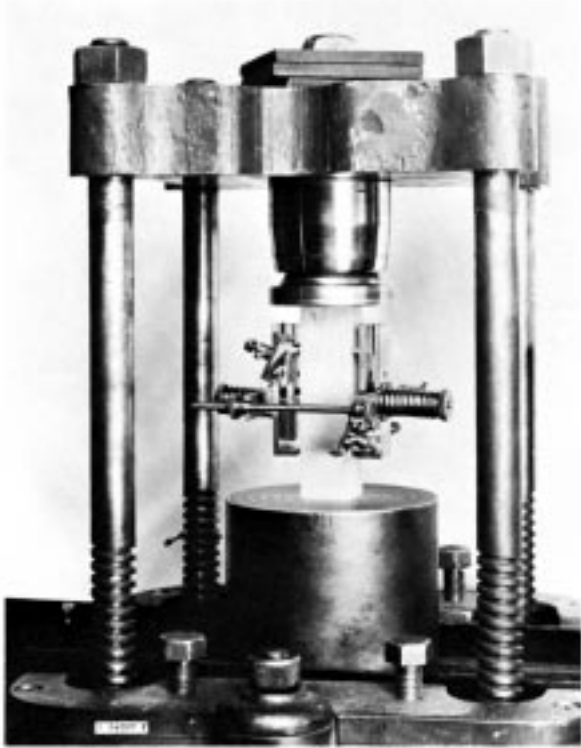

FIG. 3 Compression Test of Plywood Prism Showing Roller Compressometer Attachment (2-in. Gage Length) Affording Average Deformation for Two Opposite Faces

METHOD B—COMPRESSION TEST FOR LARGE SPECIMENS

12. Test Specimens

12.1 Specimens shall be precisely cut with all adjacent edges at right angles. The dimension of the specimen shall be 7½ in. (190 mm) wide by 15 in. (381 mm) long measured to an accuracy of not less than ±0.3 %.

12.2 To eliminate buckling, the following length-to-thickness ratios shall be used:

12.2.1 A ratio of 20 or less, if data are to be recorded up to the proportional limit only.

12.2.2 A ratio of 10 or less, if strength data only are required.

12.3 In order to obtain the specified length-to-thickness ratios, it is necessary, in some cases, to glue two or more specimens face to back.

13. Loading Procedure

13.1 Apply the load through a hinged connection on the upper head of the testing machine to allow for any deviations

from parallel of the ends of the specimens, and permit adjustment to the end of the specimen in one direction. Hold the specimen loosely by the side restraining rail. Apply the load continuously throughout the test at a rate of movable head motion that will produce failure within 3 to 10 min after initiation of loading. A head speed rate of 0.035 in./min (0.9 mm/min) ±25 % is suggested. This gives a strain rate of approximately 0.002 in./in.·min (0.002 mm/mm·min). Typical loading hardware is shown in Fig. 4 and Fig. 5.

14. Load-Deformation Curves

14.1 Take data for load-deformation curves to determine modulus of elasticity and the proportional limit. Choose increments of load so that not less than 12 readings of load and deformation are taken to the proportional limit. Take deformation readings to the nearest 0.0001 in. (0.002 mm). Take deformation over the central portion of both sides of the specimen with a gage length of 5 in. (127 mm). Use the average of the two readings in calculation of the modulus of elasticity. A suitable arrangement is shown in Fig. 5 with deformation measured by transducers mounted on opposite sides of the specimen. Record the load and deflection electrically and display continuous data on a suitable device.

REPORT

15. Report

15.1 The structural panel specimen, shall be described as to species, construction, and adhesive type used in its manufacture, and the principal direction with respect to load direction.

15.2 Data for individual specimens and specimen averages where applicable shall include the following:

15.2.1 Thickness of panel,

15.2.2 Construction and veneer thicknesses (plywood panels),

15.2.3 Veneer or furnish species,

15.2.4 Moisture content,

15.2.5 Specific gravity,

15.2.6 Elapsed time to failure,

15.2.7 Load-deflection curve or ultimate load,

15.2.8 Description of failure, and

15.2.9 Elastic modulus and ultimate compressive strength.

16. Precision and Bias

16.1 The precision and bias of these methods have not yet been determined, but when data are available, a precision and bias statement will be included.

17. Keywords

17.1 compression; structural panels; wood

ASME D 3501

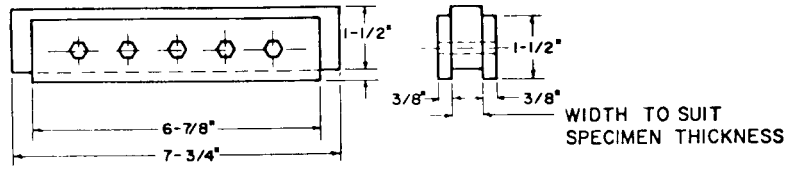

SPECIMEN LOADING BLOCKS
2 REQ'D

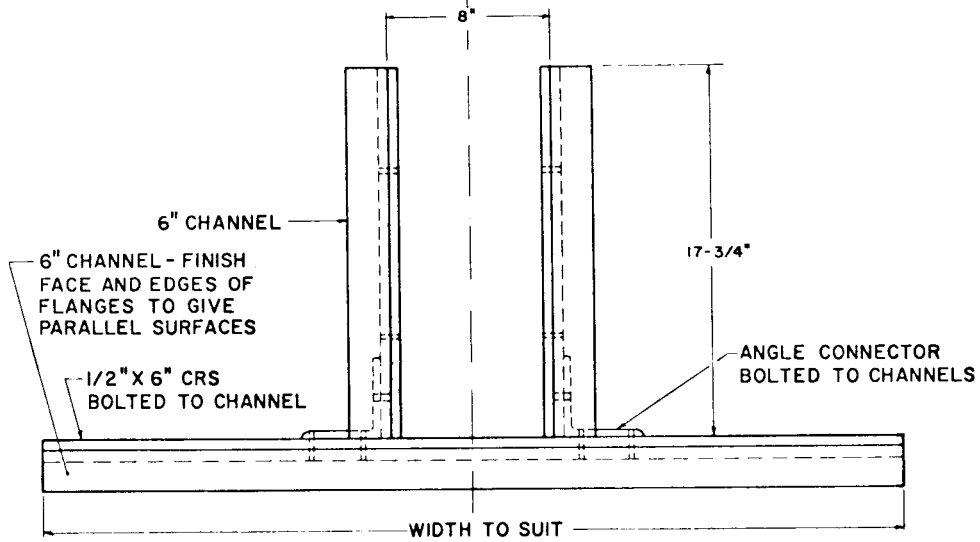
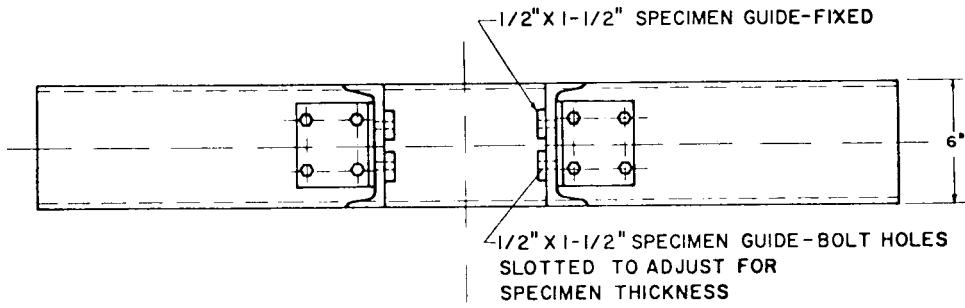

LOADING FRAME

FIG. 4 Method B, Loading Hardware

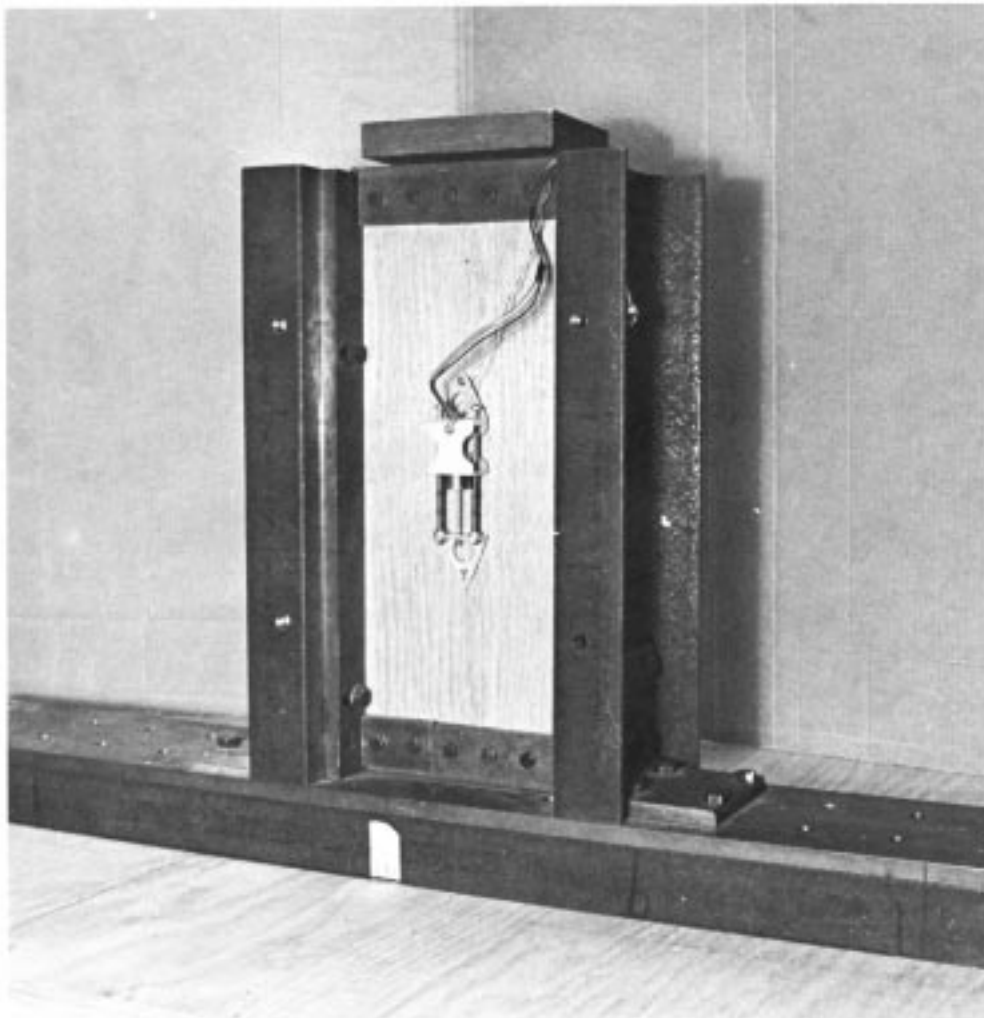

FIG. 5 Method B, Loading Hardware Showing a Specimen Mounted with Transducers for Deformation Measurement

The American Society for Testing and Materials takes no position respecting the validity of any patent rights asserted in connection with any item mentioned in this standard. Users of this standard are expressly advised that determination of the validity of any such patent rights, and the risk of infringement of such rights, are entirely their own responsibility.

This standard is subject to revision at any time by the responsible technical committee and must be reviewed every five years and if not revised, either reapproved or withdrawn. Your comments are invited either for revision of this standard or for additional standards and should be addressed to ASTM Headquarters. Your comments will receive careful consideration at a meeting of the responsible technical committee, which you may attend. If you feel that your comments have not received a fair hearing you should make your views known to the ASTM Committee on Standards, 100 Barr Harbor Drive, West Conshohocken, PA 19428.

This standard is copyrighted by ASTM, 100 Barr Harbor Drive, West Conshohocken, PA 19428-2959, United States. Individual reprints (single or multiple copies) of this standard may be obtained by contacting ASTM at the above address or at 610-832-9585 (phone), 610-832-9555 (fax), or service@astm.org (e-mail); or through the ASTM website (<http://www.astm.org>).