



Designation: D 3737 – 02

Standard Practice for Establishing Allowable Properties for Structural Glued Laminated Timber (Glulam)¹

This standard is issued under the fixed designation D 3737; the number immediately following the designation indicates the year of original adoption or, in the case of revision, the year of last revision. A number in parentheses indicates the year of last reapproval. A superscript epsilon (ϵ) indicates an editorial change since the last revision or reapproval.

1. Scope

1.1 This practice covers the procedures for establishing allowable properties for structural glued laminated timber. Properties considered include bending, tension and compression parallel to the grain, modulus of elasticity, horizontal shear, compression perpendicular to the grain and radial stresses in curved members.

1.2 This practice is limited to the calculation of allowable properties subject to the given procedures for the selection and arrangement of grades of lumber of the species considered.

1.3 Requirements for production, inspection and certification are not included, but in order to justify the allowable properties developed using procedures in this practice, manufacturers must conform to recognized manufacturing standards. Refer to ANSI/AITC A190.1 and CSA 0122.

1.4 Allowable properties established by use of this practice are based on dry conditions of use (less than 16 % moisture content). Modifications for wet-use conditions are given in 9.2.

1.5 The values stated in inch-pound units are to be regarded as standard.

1.6 *This standard does not purport to address all of the safety concerns, if any, associated with its use. It is the responsibility of the user of this standard to establish appropriate safety and health practices and determine the applicability of regulatory limitations prior to use.*

2. Referenced Documents

2.1 ASTM Standards:

- D 198 Test Methods of Static Tests of Lumbers in Structural Sizes²
- D 245 Practice for Establishing Structural Grades and Related Allowable Properties for Visually Graded Lumber²
- D 2395 Test Methods for Specific Gravity of Wood and Wood-Base Materials²
- D 2555 Test Methods for Establishing Clear Wood Strength Values²

D 2915 Practice for Evaluating Allowable Properties for Grades of Structural Lumber²

D 4761 Test Methods for Mechanical Properties of Lumber and Wood-Base Structural Material²

E 105 Practice for Probability Sampling of Materials³

2.2 Other Standards:

ANSI/AITC A190.1 - Structural Glued Laminated Timber⁴

ANSI/AF&PA - National Design Specification for Wood Construction⁵

CSA 0122 - Structural Glued Laminated Timber⁶

3. Terminology

3.1 Definitions:

3.1.1 *E-rated lumber*—lumber graded for use in manufacturing glued laminated timber by nondestructive measurement of a modulus of elasticity (E) and by visual inspection in accordance with the grading rules of the applicable grading or inspection agency.

3.1.2 *glulam*—a term used to denote glued laminated timber which is a product made from suitably selected and prepared pieces of wood bonded together with an adhesive either in a straight or curved form with the grain of all pieces essentially parallel to the longitudinal axis of the member.

3.1.3 *horizontally laminated timber*—a member designed to resist bending loads applied perpendicularly to the wide faces of the laminations (referred to as the x - x axis).

3.1.4 *lamination*—a layer of lumber within the glued laminated timber.

3.1.5 *modulus of elasticity (E)—for laminating*, E is designated in two categories to distinguish mode of measurement and application.

3.1.5.1 *Long-Span E (LSE)*—the E calculated from deflection measured in a flat-wise static bending test of lumber with a center point loading and a span depth ratio (l/d) of approximately 100 or the E Test Methods D 2555 and multiplying by the appropriate factors from Table 1.

¹ This practice is under the jurisdiction of ASTM Committee D07 on Wood and is the direct responsibility of Subcommittee D07.02 on Lumber and Engineered Wood Products.

Current edition approved Sept. 10, 2002. Published November 2002. Originally published as D 3737 – 78. Last previous edition D 3737 – 01b.

² *Annual Book of ASTM Standards*, Vol 04.10.

³ *Annual Book of ASTM Standards*, Vol 14.02.

⁴ Available from the American Institute of Timber Construction, 11818 S.E. Mill Plain Blvd., Suite 415, Vancouver, WA 98684.

⁵ Available from the American Forest and Paper Association, Washington, D.C.

⁶ Available from the Canadian Standards Association, 178 Rexdale Blvd., Rexdale, Ontario, Canada, M9W 1R3.

**TABLE 1 Adjustment Factors for Clear Wood Stresses
(Test Methods D 2555)**

Property	Multipliers for Average or Lower Exclusion Limit		Seasoning Factor for a 12 % Average Moisture Content
	Softwoods	Hardwoods	
Bending	0.476	0.435	1.35
Compression parallel to grain	0.526	0.476	1.75
Modulus of elasticity	1.095	1.095	1.20
Horizontal shear	0.244	0.222	1.13

3.1.5.2 *Member E* (E_{axial} , E_x , E_y)—the allowable E values of the glued laminated member as defined in this practice.

3.1.6 *vertically laminated timber*—a member designed to resist bending loads applied parallel to the wide faces of the laminations (referred to as bending about the y - y axis).

3.1.7 *visually graded lumber*—lumber graded by visual inspection in accordance with the grading rules of the applicable grading or inspection agency.

3.2 Symbols:

3.2.1 *GDE*—ratio of the cross-sectional area of the local grain deviation (which may or may not be associated with a knot) at the edge of the lumber to the cross sectional area of the lumber (see Fig. 1).

3.2.2 *GDC*—ratio of the cross-sectional area of the local grain deviation (which may or may not be associated with a knot) away from the edge of the lumber to the cross sectional area of the lumber (see Fig. 1).

3.2.3 *GDS*—the projected sum of all *GDE* and *GDC* values within a one-foot length of lumber as defined in Fig. 1.

3.2.4 *KE*—the ratio of cross-sectional area of knot at the edge of wide face of lumber to the cross-sectional area of the lumber (see Fig. 2).

3.2.5 *KC*—ratio of the cross-sectional area of knot located away from the edge of the lumber to the cross-sectional area of lumber. When a knot at the edge of the wide face and a knot

located away from the edge are in the same cross-section, the combination of the two shall be used in determining *KC* (see Fig. 2).

3.2.6 SR_{II} —strength ratio of the tension lamination at the outermost fiber.

4. Requirements for Laminations

4.1 Individual laminations shall not exceed 2 in. (51 mm) in net thickness. Lumber may be end-jointed to form any length of lamination or placed edge-to-edge to form any width, or both. When the member is subjected to loads parallel to the wide face of the laminations or when the member is subjected to torsion stresses, edge gluing of the laminations may be required to develop the required shear strength at the edge to edge joints.

4.2 All lumber shall be graded as either visually graded or *E*-rated lumber prior to laminating the member and suitably marked or segregated to identify its grade.

4.2.1 When pieces are ripped, each piece shall conform to applicable grade requirements. *E*-rated lumber shall be regraded for *E* after ripping except that regrading may be waived if both the *E* and tensile strength are monitored by quality control procedures referenced in ANSI A190.1, section 4.3.5.

4.2.2 If lumber is to be qualified by test as equivalent to visually graded or *E*-rated lumber, the procedures of Annex A shall be followed.

4.2.3 *E*-rated lumber shall have special visual provisions applied to those portions not subjected to mechanical test to assure piece quality.

4.3 The effect of decay or compression failures upon strength cannot be readily determined, thus these defects shall be prohibited from laminating grades insofar as existing inspection and grading technology permit. Firm white speck or light white pocket is permissible in grades of lumber that permit knots to occupy up to one third or more of the cross section provided their extent in combination with knots does

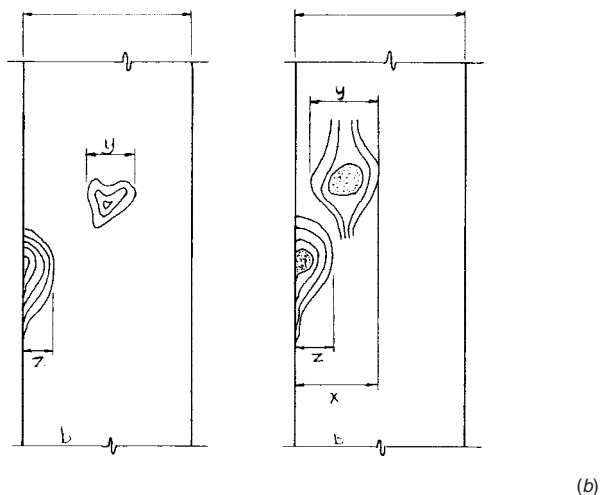

$GDC = y/b$

$GDE = z/b$

$GDS = x/b$ where $x = y + z$

(a) Example of grain deviations not associated with a knot where the projected grain deviations do not overlap.

$GDC = y/b$

$GDE = z/b$

$GDS = x/b$ where $x < y + z$

(b) Example of grain deviations associated with knots where the projected grain deviations overlap.

FIG. 1 Knot and Grain Deviation Measurement at the Outer 5% on the Tension Side of a Member Occurring in a 1-ft Length

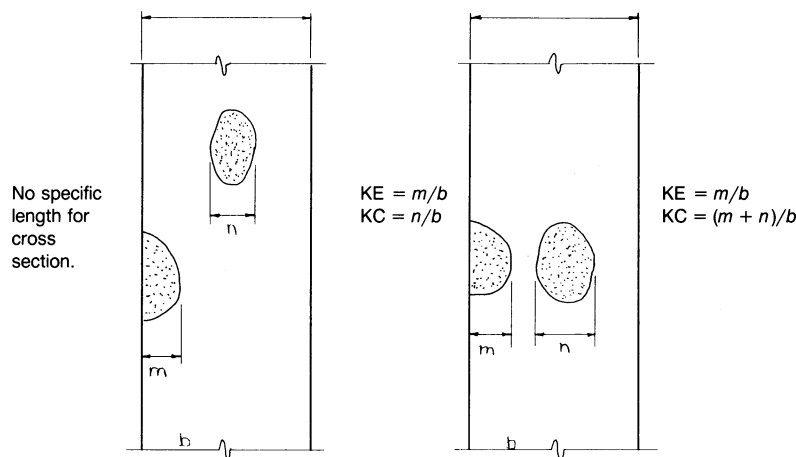

NOTE 1—When edge knots and centerline knots occur at the same cross section, the sum of the edge knots and centerline knots is used in calculating KC as shown in (b).

FIG. 2 Knot Measurement for the Next Inner 5 % on the Tension Side of a Bending Member

not exceed that of the largest edge knot permitted. The exception is that firm white speck and light white pocket shall be excluded from end joints in tension members and the outer 10 % of the total depth on the tension side of bending members.

4.4 Compression wood in readily identifiable and damaging form shall be limited in accordance with 4.4.1 and 4.4.2.

4.4.1 For dry service conditions, grades permitting knots up to one half of the cross section may contain streaks of compression wood occupying as much as 20 % of the cross section. Streaks of compression wood up to one eighth of the cross section may be permitted in other grades.

4.4.2 For wet service conditions, or for pressure-treated members, the conditions of 4.4.1 apply except that compression wood is limited to 5 % of the cross section of the laminations in tension members and in the outer 10 % of the total depth on the tension side of bending members.

4.5 Lumber shall be free of shakes and splits that make an angle of less than 45° with the wide face of the piece. Pitch pockets shall be limited in size to the area of the largest knot permitted, and pitch streaks shall be limited to one sixth of the width of the lumber.

4.6 For wet service conditions, wane is limited to that which will be removed upon final surfacing of the member. For dry service conditions, wane up to one-sixth the width of the lumber is permitted at each edge provided the allowable shear strength is adjusted to consider this unbonded region.

4.7 The range of moisture content of lumber for assembly into a single member shall not exceed five percentage points, except when all the lumber is 12 % or lower. The maximum moisture content of individual laminations is 16 %, unless the in-service conditions are wet service and in this case the maximum is 20 %.

5. Allowable Properties for Glued Laminated Timber Members

5.1 Allowable properties for specific members can be obtained by multiplying the stress index values from Section 6 by

the stress modification factors from Section 7 or 8 and modifying for specific conditions from Section 9. Exceptions are described in 5.3-5.6.

5.2 Allowable properties shall be rounded to the significant digits as shown in the following table:

Bending, tension parallel to grain, and compression parallel to grain	0 to 1000 psi to nearest 25 psi (0.3 MPa) 1000 to 2000 psi; to nearest 50 psi (0.5 MPa) 2000 to 3000 psi; to nearest 100 psi (1 MPa)
Horizontal shear	Nearest 5 psi (0.05 Mpa)
Compression perpendicular to grain and radial stresses in curved members	Nearest 5 psi (0.05 MPa)
Modulus of elasticity	Nearest 100 000 psi (500 MPa)
Calculations shall be rounded only for the final allowable property.	

5.3 Allowable properties for bending of vertically laminated members (bending about the y-y axis) using two or more grades of lumber shall be determined by the following equation:

$$f_{by} = E (f_{bx}/E)_{min} \quad (1)$$

where:

- f_{by} = allowable bending property of the vertically laminated beam combination made up of two or more grades of lumber,
- E = weighted average of the component lamination LSE values,
- $(f_{bx}/E)_{min}$ = ratio of allowable bending property to LSE for each grade of lumber in the beam combination. The lowest ratio is used in Eq 1.

f_{bx} = allowable bending property for a grade in the combination which is obtained by multiplying the stress index value from Section 6 by the stress modification factor calculated using Eq 4 and modifying for specific conditions from Section 9.

E = corresponding *LSE* for a grade in the combination.

5.4 The modulus of rigidity of glued laminated members can be considered to have a constant relationship to the modulus of elasticity. For design purposes, the relationship $G = E_x/16$ is satisfactory for members consisting of a single grade. A conservative approximation for members consisting of multiple grades of lumber can be obtained by using the *LSE* of the lowest grade applied to the entire member.

5.5 Radial Stress in Curved Members:

5.5.1 *Radial Tension*—allowable properties for radial tension in curved members shall be limited to one third of the value for horizontal shear as determined in accordance with 6.1.5, except for Douglas fir-Larch and Hem-fir, which are limited to 15 psi (0.10 MPa) for other than wind or earthquake loads. For wind and earthquake loading of all species, adjustments to the allowable property shall be based on one-third of the value for horizontal shear.

5.5.2 *Radial Compression*—allowable properties for radial compression in curved members shall be limited to the allowable property for compression perpendicular to the grain.

5.6 Member E:

5.6.1 *Axially Loaded, Symmetric Combinations*—allowable E_{axial} is determined by using the weighted average of the individual lamination grade *LSE* values. *LSE* is determined according to procedures in 3.1.5.1 or by alternate procedures in 6.2.4.1.

5.6.2 *Vertically Laminated Combinations*—allowable E_y is determined by the procedure in 5.6.1 and further adjusting by multiplying by 0.95.

5.6.3 *Horizontally Laminated Combinations*—allowable E_x is determined by a transformed section analysis and further adjusted by multiplying by 0.95 such as shown in Annex A4.

6. Stress Index Values

6.1 *Visually Graded Lumber*—Test Methods D 2555 provides information on clear wood strength properties and their expected variation for small clear, straight-grained specimens of green lumber. Based on these properties, stress index values shall be calculated.

6.1.1 *Bending*—Determine a stress index value by calculating the fifth percentile of modulus of rupture in accordance with Test Methods D 2555, multiplying by the appropriate factors in Table 1, and furthermore multiplying by 0.743 to adjust to a 12-in. (0.3-m) deep, uniformly loaded simple beam with a 21:1 span-to-depth ratio.

6.1.1.1 Tests of large glued laminated timber beams of Douglas fir-Larch, southern pine and Hem-Fir indicate that the stress index value in bending, based on test and analysis and given in Table 2, may be used instead of the procedure in 6.1.1 for Douglas fir-Larch, grown within the states of Wyoming, Montana, Washington, Idaho, Oregon, and California; for southern pine consisting of the four principal species: longleaf, slash, shortleaf, and loblolly; and for Hem-Fir consisting of Western Hemlock, California Red Fir, Grand Fir, Noble Fir, Pacific Silver Fir and White Fir.

6.1.2 *Compression Parallel to the Grain*—Determine a stress index value by calculating the-fifth percentile of compression parallel to the grain in accordance with Test Methods D 2555 and multiplying by the appropriate factors from Table 1.

6.1.3 *Tension Parallel to the Grain*—Determine a tension value by using 5/8 of the bending stress index for 12-in. (0.3-m) deep members obtained in 6.1.1.

6.1.4 *Modulus of Elasticity*—Obtain a stress index value from an average modulus of elasticity for the species or species group from Test Methods D 2555. From that, obtain *LSE* by multiplying by the appropriate factors from Table 1. This adjusts values to a span-to-depth ratio of 100:1 and an assumed uniform loading.

6.1.4.1 The modulus of elasticity values in Table 2 are *LSE* values based on testing of large samples of lumber of the species groups listed in 6.1.1.1 and may be used instead of values determined by the method in 6.1.5.1.

TABLE 2 Bending Stress Index Based on Large Beam Tests and Modulus of Elasticity Values for Visually Graded Lumber

NOTE 1—Appendix X1 provides one method of developing new data.

Species	Growth Classification ^A	Bending Stress Index ^B		Modulus of Elasticity	
		psi	MPa	million psi	MPa
Douglas Fir-Larch	medium grain	3 000	20.7	1.9	13 100
	close grain	3 250	22.4	2.0	13 800
	dense	3 500	24.1	2.1	14 500
Southern Pine	coarse grain ^C	2 000	13.8	1.5	10 300
	medium grain	3 000	20.7	1.8	12 400
	dense	3 500	24.1	2.0	13 800
Hem-Fir	medium grain	2 560	17.7	1.7	11 700
	dense ^D	3 000	20.7	1.8	12 400

^A Classification for "dense" wood shall follow Practice D 245.

^B Values shown are based on full-size beam tests. As a result, these values incorporate the effects of some features such as grain deviations in lumber along with influences of end and face bonding influences. Beams designed using these values and tested in accordance with Test Methods D 198 will yield strength values such that the lower fifth percentile will exceed the design bending stress by a factor of 2.1 with 75 % confidence. Analysis of test data assumed a log normal distribution. For unsymmetric combinations, tests have shown that values up to 40 % higher than those listed may be applied to the compression side of bending members.

^C Also applicable to minor species of southern pine regardless of growth rate.

^D Specific gravity, based on oven-dry weight and volume at 12 % moisture content, must equal or exceed 0.39.

6.1.5 *Horizontal Shear*—Determine a stress index value by calculating the lower fifth percentile tolerance limit of clear wood shear strength in accordance with Practice D 2915 using the data given in Test Methods D 2555 and multiplying by the appropriate factors from Table 1. The horizontal shear stress index for coarse-grain Douglas fir-Larch and southern pine shall be 70 % of the value used for medium-grain materials.

6.1.5.1 As an alternative to 6.1.5, the horizontal shear stress index shall be permitted to be determined from flexural tests of full-size beams in accordance with the principles of Test Methods D 198 with specific loading details as shown in Annex A7. Laminating lumber used in the critical core area of the test beams subjected to maximum shear stresses shall be selected such that it is representative of the population of on-grade lumber used in normal production for the species and grade being evaluated. The required number of samples and the lower 5th percentile tolerance limit of shear strength shall be determined in accordance with Practice D 2915 and the analysis procedures given in Annex A7. The horizontal shear stress index is determined by multiplying the lower 5th percentile tolerance limit of shear strength by 1/2.1. Reassessment of the horizontal shear stress index derived from this section shall be conducted for beam configurations that are not included in the consideration of the testing described in this section, or if there is a significant change in the lumber resource or in the lamination grading system or the manufacturing process.

6.1.6 *Compression Perpendicular to the Grain*—Determine a stress index value as follows (1):⁷

$$F_{C\perp} = (2674 SG - 551.3) (1.9/1.67) \quad (2)$$

where:

$F_{C\perp}$ = stress index value in compression perpendicular to grain, and

SG = average green specific gravity from Test Methods D 2555 or, for a species group, the standing timber volume weighted average green specific gravity; adjusted as shown in 6.1.6.1, 6.1.6.2, or 6.1.6.3.

6.1.6.1 For purposes of calculating stress index values in compression perpendicular to grain for visually graded material, the average green specific gravity of a species or species group which have an average green specific gravity of 0.36 or above shall be reduced by the following amounts for various rates of growth and density to account for variation in the specific gravities.

- Dense grain—0.03
- Close grain—0.05
- Medium grain—0.06
- Coarse grain—0.09

6.1.6.2 When the average green (specific gravity) of a species or species group is 0.35 or less the reductions are as follows:

- Close grain—.03
- Medium grain—.04

6.1.6.3 As an alternative to the method specified in 5.6.1 of Practice D 245, lumber shall be qualified as dense by weighing.

The lumber specific gravity, adjusted to a green condition using Test Methods D 2395, Appendix X1 conversion formula, shall meet the reduced specific gravity as specified in 6.1.6.1. The reduced value shall be used in Eq 2 to determine the stress index value in compression perpendicular to grain.

6.2 *E-rated Lumber*—This method is based on lumber that has been E-rated and visually graded in accordance with Annex A1. E-rated lumber is designated by the modulus of elasticity and the size of the edge characteristics permitted in the grade such as 1.6E-1/3, etc. Edge characteristics include knots, knot holes, burls, localized grain deviation or decay (partially or wholly) at edges of wide faces.

6.2.1 Bending stress index values for lumber with various LSE values are given in Table 3.

6.2.1.1 Stress index values in bending for E-rated lumber shall be no lower than those for visually graded lumber in Table 2 for the same species and equal LSE. Also, the stress index values of any E-rated grade of a specific species shall be no lower than that of a No. 3 visual grade of lumber provided the long span E's are comparable (No. 3 grade structural lumber is defined in most grading rules)

6.2.2 Compression parallel to grain stress index values are included in Table 3.

6.2.3 *Tension Parallel to the Grain*—Determine a tension by using 5/8 of the bending stress index for 12-in. (0.3-m) deep members obtained in 6.2.1.

6.2.4 *Modulus of Elasticity*—The E values for E-rated lumber shall be the LSE as defined in 3.1.5.1.

6.2.4.1 LSE values may be determined by tests of lumber using the procedure of Annex C and meeting the criteria of Annex A2.

6.2.5 *Horizontal Shear*—The stress index value shall be determined in the same manner as for visually graded lumber in 6.1.5.

6.2.6 *Compression Perpendicular to Grain*—Stress indexes for E-rated lumber is determined by using the LSE-rated grade listed in Table 3 and the growth classifications.

(1) *Dense*—If the LSE equals or exceeds that of the dense classification for the species, the stress index for the dense visual grade of the species or species group is used per 6.1.6

(2) *Medium Grain*—If the LSE of the E-rated grade of lumber is less than the average LSE of the species or species groups, but no less than 300 000 psi below the average, use the compression perpendicular to grain value determined for medium grain lumber per 6.1.6.

(3) *Other*—When the LSE is less than the average LSE minus 300 000 psi, determine the compression perpendicular to

TABLE 3 Bending Stress Indexes and Compression Stress Index Parallel to Grain for E-Rated Lumber Used in Laminating^A

Long Span, E, psi	Bending Stress Index, ^A psi	Compression Stress Index Parallel to Grain, ^{B,C} psi
1 600 000	2 560	1 900
1 900 000	3 000	2 400
2 100 000	3 500	2 800
2 300 000	4 000	3 100

^A Values shall be not higher than obtained by interpolation for intermediate E values.

^B Values are for 12-in. deep members at 12 % moisture content (dry).

^C Values are for members at 12 % moisture content (dry) values.

⁷ The boldface numbers in parentheses refer to a list of references at the end of this practice.

grain values by using a specific gravity of 0.8 times the average specific gravity of the species in solving Eq 2. (The value obtained is approximately the same as that used for coarse grain lumber.)

6.2.6.1 As an alternative to 6.2.6, the allowable property for compression perpendicular to grain may be determined in accordance with the applicable provisions of Refs 2, 3, 4 and 5.

7. Procedure for Determining Stress Modification Factors (SMF) for Glued Laminated Timber Made of Visually Graded Lumber

7.1 For some strength properties, knots, slope of grain, and other characteristics may affect the strength and therefore reductions in the stress index values are required. Conversely, some properties are not affected by these characteristics and no modification is necessary.

7.1.1 Special tension lamination grades of lumber as described in Section 10 are required to justify the bending stress modifications.

7.2 *Bending Stress Modification Factor*—The bending stress modification factor is the lower of the two modification factors determined on the basis of knots and on the basis of slope of grain.

7.2.1 The bending stress modification factor for members loaded perpendicular to the wide faces of the laminations (horizontally laminated beams) shall be determined as follows:

7.2.1.1 *Knots*—Knots affect strength less if located in laminations near the neutral axis than in outer laminations. Thus, the influence of knots depends both on their size and position and is best measured by their moment of inertia. Tests of glulam beams have provided an empirical relationship between the ratio I_K/I_G and bending strength. I_K is defined as the moment of inertia of all knots within 6 in. (152 mm) of the critical cross section and I_G is the gross moment of inertia. Knot properties shall be determined following the procedures given in Annex A3 and I_K/I_G ratios shall be calculated following procedures given in Annex A4. Additional information is given in Refs 6 and 7). Determine the stress modification factor in bending from the following relationship:

$$SMF_b = (1 + 3R)(1 - R)^3(1 - R/2) \quad (3)$$

where:

SMF_b = bending stress modification factor, and
 R = I_K/I_G ratio.

For multiple grade laminations, several SMF_b values are calculated and compared as shown in Annex A4.

The minimum value of SMF_b shall not be less than the strength ratio in flatwise bending as determined by formula X1.2 of Practice D 245.

7.2.1.2 *Slope of Grain*—Modification factors associated with various slopes of grain are given in Table 4. Those given for tension apply to lumber in the tension side of bending members while those given for compression apply to that in the compression side.

7.2.2 The bending stress modification factor for vertically laminated beams (members loaded parallel to the wide faces of the laminations) shall be determined as follows:

TABLE 4 Parallel to Grain Stress Modification Factors Associated with Slope of Grain for Designing Glulam Combinations

Slope of Grain	Stress Modification Factor	
	Tension	Compression
1:4	0.27	0.46
1:6	0.40	0.56
1:8	0.53	0.66
1:10	0.61	0.74
1:12	0.69	0.82
1:14	0.74	0.87
1:15	0.76	1.00
1:16	0.80	1.00
1:18	0.85	1.00
1:20	1.00	1.00

7.2.2.1 *Knots*—Determine the effect of knots on vertically laminated beams of a single grade of lumber by calculating a stress modification factor, SMF , by the following empirical relationship (see Ref 8 for further details):

$$SMF = C_1(SR_1^\gamma)(N^\alpha)(1 - 1.645 \Omega_1/N^{1/2}) \quad (4)$$

where:

C_1 = empirical constant from Table 5,
 SR_1 = strength ratio from Practice D 245 for an individual piece of lumber loaded on edge,
 γ = empirical constant equal to 0.81,
 α = $0.329(1 - 1.049SR_1)$,
 N = number of laminations in the member of the same grade or higher up to 5. Use $N = 5$ for members with five or more laminations of the same grade or higher, and
 Ω_1 = coefficient of variation of bending strength for one lamination. The coefficient of variation for one lamination of visually graded lumber = 0.36.

7.2.2.2 *Slope of Grain*—Bending stress modification factors associated with various slopes of grain are equal to those for tension stress in Table 4 assuming the steepest slope of grain permitted in the grade.

7.3 *Stress Modification Factors in Compression Parallel to the Grain*:

7.3.1 The modification factor is the lower of the two modification factor ratios determined separately from both knots and slope of grain as follows:

7.3.2 *Knots*—Tests have shown that axial compressive strength of short compression members is related to the percent of the cross section occupied by the largest knot for individual laminations. Procedures for estimating values of this percentage for compression members are given in Annex A5. Derive the stress modification factor in compression from the following empirical relationship.

TABLE 5 Constant Used to Adjust Vertically Laminated Bending Strength Ratio

Strength Ratio (SR_1)	C_1
0.45 or greater	1.238
0.40	1.292
0.35	1.346
0.30	1.400
0.26 or less	1.444

$$SMF_c = Y^3/4 - Y^2 - Y/4 + 1 \quad (5)$$

where:

SMF_c = compression stress modification factor, and
 Y = knot size at the 99.5 percentile, expressed in a decimal fraction of the dressed width of lumber used for the lamination.

For members with grades of lumber placed unsymmetrical, an additional adjustment such as given in Annex A5 is necessary to compensate for additional bending stresses.

7.3.3 Slope of Grain—Modification factors in compression associated with various slopes of grain are given in Table 4. When compression members consist of different grades, determine a weighted average stress modification factor.

7.3.4 The modification factor in compression parallel to grain for members of two or three laminations of the same grade of lumber shall be the same as the strength ratio determined using Practice D 245 for a single piece of lumber of the grade being used.

7.4 Stress Modification Factors in Tension Parallel to the Grain:

7.4.1 The modification factor to use in determining allowable properties is the lower of the two modification factors determined on the basis of knots and on the basis of slope of grain as follows:

7.4.2 Knots—Determine the modification factor in tension as governed by knots as follows:

$$SMF_t = 1 - Y_2 \quad (6)$$

where:

SMF_t = tensile stress modification factor, and
 Y_2 = maximum edge knot size permitted in the grade expressed in a decimal fraction of the dressed width of the wide face of the piece of lumber used for the lamination. (Centerline knot size shall be limited to that resulting in an equivalent edgewise bending strength ratio as determined by Practice D 245.

7.4.3 Slope of Grain—Stress modification factors in tension are given in Table 4.

7.5 Member Modulus of Elasticity (E):

7.5.1 The E_x of glulam members is directly dependent upon the LSE of laminations used in its manufacture. When LSE is determined by test methods other than those described in 3.1.5.1, then modification factors described in Section 4.3 of Practice D 2915 shall be applied. When LSE is determined using the Test Methods D 2555 procedures described in 3.1.5.1, then modification factors from Table 6 shall be applied.

7.5.1.1 The E values given in Table 2 may be used as alternatives to those determined from 7.5.1. These values were determined by surveys of laminating grades adjusted to standard test conditions.

TABLE 6 Grade Adjustment Factors for Modulus of Elasticity

Bending Strength Ratio ^A	Adjustment Factor
0.55 or greater	1.00
0.45 to 0.54	0.90
0.44 or less	0.80

^A Determined in accordance with Practice D 245.

7.5.2 The E values for axially loaded symmetric combinations of members shall be assumed to be the weighted average of the component lumber used in the member.

7.5.3 The E values applicable to vertically laminated combinations shall be 95 % of the average of the laminations.

7.5.4 E values applicable to horizontally laminated bending combinations shall be 95 % of the value calculated by the transformed section analysis (see Annex A4).

7.6 Horizontal Shear:

7.6.1 Horizontally Laminated Members—By restricting shakes and splits as given in 4.5, the modification factor for horizontal shear in horizontally laminated members is 1.0.

7.6.1.1 For wet service conditions, wane is limited to an amount that will be removed during final surfacing of the member and a stress modification of 1.0 is applicable. For dry service conditions the stress modification factor in horizontal shear is calculated as the ratio of the wane-free width to total surfaced width. Thus, when wane up to 1/6 of the width is allowed along both edges, the stress modification factor is 2/3.

7.6.2 Vertically Laminated Timbers—For members consisting of four or more laminations, one out of four pieces is assumed to have a check or split that limits its modification factor in shear to 1/2 resulting in a modification factor of the composite of 7/8. For two and three lamination beams, the modification factor is 3/4 and 5/6, respectively. When species having different shear properties are combined in a glued laminated timber, use a weighted average to determine the stress index value in shear.

7.7 Stress Modification Factor for Compression Perpendicular to Grain and Radial Tension:

7.7.1 A stress modification factor of 1.0 shall be applicable to glulam combinations.

8. Procedure for Determining Stress Modification Factors (SMF) for Glued Laminated Timber Made of E-Rated Lumber

8.1 The determination of the stress modification factors for glued laminated timbers made with E -rated lumber is similar to that for visually graded lumber except that the effect of slope of grain is accounted for in the LSE value and slope of grain stress modification factors are not used. However, the tension laminations prescribed for the outer 5 % of bending members have specific slope of grain restrictions. See 10.2.3.1.

8.2 Bending Stress Modification Factor:

8.2.1 Horizontally Laminated Members—Determine the bending stress modification factor by the I_K/I_G method used for members made of visually graded lumber as shown in Annex A4.

8.2.1.1 The minimum stress modification factor shall not be less than the modification factor given in Table 7 for members 15 in. or less in depth. The minimum value for SMF_b shall not be less than 0.50 for members of greater depths.

8.2.2 Vertically Laminated Members—Determine the bending stress modification factor by use of Eq 4. The coefficient of variation, COV, for E -rated lumber for use in Eq 4 is 0.24, except where the edge characteristics occupy one half of the cross section; in which case, the coefficient of variation is the same as for visually graded lumber (0.36).

TABLE 7 Minimum Bending and Compression Parallel to Grain Stress Modification Factors for Members of E-Rated Lumber

E-Grade ^A Designation	Minimum Stress Modification Factor (SMF) Bending		
	Horizontally Laminated Members	Vertically Laminated Members	Compression ^B Parallel to Grain
1/6	0.70	0.70	0.70
1/4	0.65	0.65	0.70
1/2	0.50	0.25	0.50

^A The second part of the E-grade designation (for example, 2.0-1/6) indicates fraction of cross section that can be occupied by edge characteristics which include knots, knot holes, burls, distorted grain, or decay partially or wholly at edges of wide faces.

^B Values are for members of two or more laminations.

8.3 Stress Modification Factor for Compression Parallel to Grain:

8.3.1 The modification factor is based on a knot size study as shown for visually graded lumber in 7.3.2 and Annex A5.

8.4 Stress Modification Factor in Tension Parallel to Grain:

8.4.1 Determine the modification factor in tension that is governed by knots using Eq 6 and procedures of 7.4.2 with the exception that only edge knots are considered in determining Y_2 .

8.5 Stress Modification Factor for E:

8.5.1 Use the same procedure as given in 7.5.1.

8.6 Stress Modification Factor for Horizontal Shear:

8.6.1 The modification factor for horizontal shear is determined in the same manner used for visually graded lumber in 7.6.

8.7 Stress Modification Factor for Compression Perpendicular to Grain and Radial Tension:

8.7.1 A stress modification factor of 1.0 shall be applicable to glulam combinations.

9. Adjustment of Properties for End-Use Conditions

9.1 The allowable properties developed using Sections 6, 7, and 8 are based on normal load duration (9.3), 12 % average moisture content conditions, and approximately 68°F (20°C) temperatures. Bending stress is for a 12-in. (0.3-m) deep straight beam, uniformly loaded with a 21:1 span-to-depth ratio. Design at other conditions requires modifications.

9.2 **Moisture Content**—Two different moisture conditions are recognized for glulam members, dry service and wet service. Dry service is the use condition where the moisture content of the wood is less than 16 %. Wet service is the use where wood attains moisture contents of 16 % or more. For wet service conditions, properties developed using Sections 6, 7, and 8 should be multiplied by factors given in Table 8.

9.3 **Duration of Load**—Normal load duration contemplates fully stressing a member to its allowable value either continuously or cumulatively for ten years. For other durations of load,

all properties except E and compression perpendicular to grain may be modified in accordance with Practice D 245.

9.4 **Size Effect or Flat Use Factor**—For bending members, the bending stress must be adjusted for depths other than 12 in. (0.3 m) by multiplying by $(12/d)^{1/9}$ where d is the beam depth, in inches, or $(0.3/d)^{1/9}$ where d is the beam depth in meters. Under some condition, adjustments for method of loading (Table 9) and span-to-depth ratio (Table 10) may also be necessary. For span-to-depth ratios other than those given, straight-line interpolations may be used.

9.5 **Curvature**—For the curved portion of members, the allowable bending property shall be modified by the following factor, $1 - 2000(t/R)^2$ where t is the lamination thickness and R is the radius of curvature, both in similar units of measurement. Experience has shown that in order to minimize breakage problems during manufacture, the t/R ratio should not exceed 1/100 for hardwoods and southern pine and 1/125 for other softwood species.

9.6 Treated Wood:

9.6.1 Allowable properties associated with preservative or fire-retardant treated members, whether the lumber is treated prior to gluing or the entire member is treated following gluing, must take into account possible reductions due to high temperatures, pressure, or chemical effects associated with the treating process. When reductions are applicable they must be based on tests of material subjected to the specific treatment conditions.

9.6.2 Members incised prior to preservative treatment may be subjected to a strength reduction depending on member size and the incision pattern and configuration. Such reductions must be based on tests of the incised material.

9.7 **Temperature**—Reductions in some allowable properties are applicable when the member is exposed to abnormally high temperatures, especially for extended periods of time, or for exposure combining high temperatures and high moisture content. Increases to some allowable properties may be applicable for members used in continuous cold climatic conditions. See guidelines are given in Ref (9).

9.8 **Shear Deflection**—member E values for bending combinations, calculated in accordance with 7.5 and 8.5 are applicable for a 21:1 span-to-depth ratio and assume that up to 5 % of the deflection will be due to shear and about 95 % due to bending when loaded uniformly. Such values may be applied to all loading conditions with span-to-depth ratios greater than 14:1 and the maximum deflection error due to shear will be of the order of 5 % or less. For more precise deflection calculations or for span-to-depth ratios less than 14:1, the effect of shear deflections should be considered separately.

TABLE 8 Wet-Use Adjustment Factors

Type of Stress	Wet-Use Factor
Bending	0.800
Compression parallel to the grain	0.730
Tension parallel to the grain	0.800
Modulus of elasticity	0.833
Horizontal shear	0.875
Compression perpendicular to the grain	0.530

TABLE 9 Bending Stress Adjustment Factors for Loading Conditions

Loading Conditions for Simply Supported Beams	Adjustment Factor
Single concentrated load	1.08
Uniform load	1.00
Third-point load	0.97

TABLE 10 Adjustment Factors for Span-to-Depth Ratios

Span-to-Depth Ratio	Adjustment Factor
7	1.06
14	1.02
21	1.00
28	0.98
35	0.97

10. Tension Laminations for Bending Members

10.1 The results of full-size beam tests reported in Refs **6**, **10**, and **11** have yielded an empirical relationship between the size of knots in the tension zone and bending strength. This relationship dictates that special grading considerations be applied to the laminations used in the outer 10 % of the beam depth on the tension side. This tension side may exist on the top or bottom of the beam, or both, depending upon design considerations. Consideration must be given to approximately matching the LSE or density of these tension grade laminations at end joints. When members are manufactured without these special tension lamination grading considerations being applied, the allowable bending property is obtained by multiplying the allowable property calculated in Sections 7 and 8 by 0.85 if the depth is 15 in. or less or by 0.75 if the depth exceeds 15 in.

10.1.1 The outer 10 % is further divided into two zones, the outer 5 % and the next inner 5 %.

10.1.2 The use of the equations in 10.2 for the outer 5 % zone is limited to tension laminations with SR_{11} values of 0.5 to 0.82 because bending tests cited used tension laminations within that range.

10.2 Visually Graded Lumber:

10.2.1 For definitions of terms required for calculation of knot and grain deviation restrictions, see 3.2.

10.2.2 Knots and local grain deviations are expressed as a ratio of the cross-sectional area they occupy to the cross-sectional area of the lumber based on the dressed width of the lumber. They are measured using the displacement technique. Knots are measured to the lateral extremes of the knot; grain deviations (with or without knots) are measured to the lateral extremes of the zone within which the local slope of grain exceeds the allowable slope of grain for the grade. Eq 7-10 which follow yield the maximum allowable knot and grain deviation ratios in the outer 10 % of depth. It is suggested these ratios be adjusted downward to the nearest 0.05 or to the next nearest convenient fraction (such as $\frac{1}{3}$). Examples of knot and grain deviation restrictions for tension lamination grades are given in Table 11.

10.2.3 Beams Greater than 15 in. in Depth:

10.2.3.1 Outer 5 %—Grain deviation shall be limited in accordance with Eq 7 and 8.

$$GDS \leq 1.55(1 - SR_{11}) \quad (7)$$

$$GDS \leq 1.82(1 - SR_{11}) \quad (8)$$

Use Eq 7 when GDE, with or without GDC, is used to determine GDS (see Fig. 1). Use Eq 8 when GDE is not used to determine GDS. In addition, general slope of grain shall not exceed 1:16 if the required strength ratio of the tension

TABLE 11 Examples of Knot and Knot Plus Grain Deviation Restrictions for Tension Lamination Grades

Strength Ratio ^A (SR_{11})	Outer 5 %		Next Inner 5 %	
	GDE ^B	GDC ^B	KE ^B	KC ^B
0.80	0.310	0.364	0.300	0.456
0.75	0.388	0.455	0.323	0.503
0.70	0.465	0.546	0.345	0.549
0.65	0.543	0.637	0.368	0.596
0.60	0.620	0.728	0.390	0.642
0.55	0.698	0.819	0.413	0.689
0.50	0.775	0.910	0.435	0.735

^A Tension lamination strength ratio at the outermost fiber.

^B See 3.2 for definitions of terms.

lamination is 0.60 or greater. If it is less than 0.60, the general slope of grain shall not exceed 1:12.

10.2.3.2 Next Inner 5 %—Knots are restricted in accordance with Eq 9 and 10.

$$KE = 0.66 - 0.45 SR_{11} \quad (9)$$

$$KC = 1.20 - 0.93 SR_{11} \quad (10)$$

General slope of grain shall be limited in accordance with the strength requirements of the individual laminations.

10.2.4 Beams 12 to 15 in. in Depth:

10.2.4.1 Outer 5 %—The requirements of 10.2.3.1 apply except that SR_{11} shall be multiplied by 0.90 in Eq 8 and 9. The value of 0.9 SR_{11} shall not be less than 0.50.

10.2.4.2 Next Inner 5 %—General slope of grain shall be limited in accordance with the strength requirements of the individual laminations.

10.2.5 Beams of four or more laminations and less than 12 in. in depth:

10.2.5.1 Outer 5 %—The requirements of 10.2.3.1 apply except that SR_{11} shall be multiplied by 0.80 in Eq 8 and 9. The value of 0.80 SR_{11} shall not be less than 0.50.

10.2.5.2 Next Inner 5 %—General slope of grain shall be limited in accordance with the strength requirements of the individual laminations.

10.2.6 Density Requirements:

10.2.6.1 Outer 5 %—Density requirements shall apply to the full length of the piece of lumber. In order to ensure that lumber is near-average or above specific gravity for the species, visually graded tension laminations shall have a minimum specific gravity of at least 94 % of the recognized species average from Test Methods D 2555 based on dry weight and volume at 12 % moisture content. The minimum specific gravity of the piece of lumber shall be the average specific gravity of the entire piece. Rate of growth and percentage of latewood requirements for tension laminations shall apply to the full length of lumber. Visual inspection alone is not an acceptable method of determining specific gravity.

10.2.7 Other Requirements:

10.2.7.1 Outer 5 %—Wide-ringed or lightweight pith associated wood has a pronounced effect on finger joint strength. The amount of material not meeting rate of growth and density requirements, in combination with compression wood, shall be limited to $\frac{1}{8}$ of the cross section of the piece of lumber. In addition, for wet service conditions or pressure-treated members, compression wood is limited to a maximum of 5 % of the cross section.



10.2.7.2 *Next Inner 5 %*—There are no special requirements.

10.3 *E-rated Lumber:*

10.3.1 *Grading Requirements:*

10.3.1.1 *Outer 5 %*—In addition to having the required modulus of elasticity, *E*-rated lumber must meet the requirements for visually graded lumber given in 10.2.2, 10.2.3.1, and 10.2.4.1, with the exception of the knot and slope of grain requirements as given in 10.3.3.

10.3.1.2 *Next Inner 5 %*—There are no special requirements.

10.3.2 *Other Requirements:*

10.3.2.1 *Outer 5 %*—Wide-ringed or lightweight pith associated wood and compression wood are limited in the same manner as for visually graded lumber, except that there are no density requirements. Material not meeting medium grain rate of growth, in combination with compression wood, shall be limited to 1/8 of the cross section of the piece of lumber. In addition, for wet conditions of use or pressure-treated members, compression wood is limited to a maximum of 5 % of the cross section.

10.3.2.2 *Next Inner 5 %*—There are no special requirements.

10.3.3 The portions of the piece not subjected to mechanical *E* measurements shall have visual criteria applied to ensure piece quality. Edge knots up to the size permitted in the grade are acceptable. Other knots are limited to the visual requirements of the bending stress index for which the *E*-rated lumber is qualified. For tension laminations, the slope of grain shall not exceed 1:12 and wide-ringed or pith-associated wood and compression wood is limited as in 10.3.2. Medium grain growth requirements shall be met for Douglas Fir-Larch and Southern Pine material.

10.4 Tension laminations to meet the requirements identified in 10.1 may be qualified by test as an alternative to the grading criteria of 10.2 and 10.3. The procedure given in Annex A1 shall be used.

11. Keywords

11.1 clear wood; glulam; lumber; structural glued laminated timber; timber

ANNEXES

(Mandatory Information)

A1. QUALIFICATION OF LAMINATIONS BY TEST

A1.1 If lumber is to be qualified by test as equivalent to visually graded or *E*-rated laminations, procedures in this section shall be followed. Tests shall include long span *E*, tensile strength and specific gravity. Values for compression perpendicular to the grain and horizontal-shear shall be determined following procedures previously described in this standard.

A1.1.1 Qualification shall be carried out on the size and grade of product for which qualification is desired, except that qualification at a specified width will satisfy qualification requirements for the next smallest width.

A1.1.1.1 If qualification of a width by test is used to qualify the next smaller width, selection criteria for the grade of both widths must be identical.

NOTE A1.1—As an example, qualification of a 2.0E, 1/8 edge knot grade in nominal 2 by 6 for a tension lamination target will qualify the same grade in 2 by 4 if the same *E* selection levels and edge knot selection criteria are used.

A1.1.1.2 Principles of Practice D 2915 shall be followed in sampling. A sample of 50 or more is required for *E* measurements; a minimum of 58 is required for tensile strength.

A1.2 Qualification by test shall include a flatwise bending modulus of elasticity on a 100:1 span-to-depth ratio (see 3.1.5.2).

A1.2.1 Qualification tests for *LSE* shall be carried out in accordance with Test Methods D 198 or Test Method D 4761.

A1.2.2 To qualify by *E* criterion, the average *LSE* (*E*) of the sample shall meet the following criteria:

$$(E) [(1 + (0.237) (COV))] \geq E_o \quad (A1.1)$$

where:

COV = coefficient of variation of *E* in the candidate stock, and

*E*_o = average *LSE* of the target grade for which replacement is sought.

NOTE A1.2—For example, assume the target grade is 302-24 from *D*. Fir L with a *LSE* of 2.1×10^6 psi. The candidate stock is MSR lumber. The *COV* of the qualification sample does not exceed 0.11 as given in the NDS (12). The product of *LSE* of the candidate sample and 1.026 must equal or exceed 2.1. As a second example, assume the target grade is 302-24 from Hem-Fir SSS with a *LSE* of 1.8×10^6 psi. The candidate stock is visually graded; the National Design Specification (NDS) *COV* for visually graded lumber is 0.25. The product of *LSE* of the candidate stock and 1.059 must equal or exceed 1.8.

A1.3 Qualification shall include a strength test of full-size laminations in tension.

A1.3.1 Tensile testing procedures shall follow the principles of Test Methods D 198 or Test Method D 4761 with a minimum gage length of 8 ft.

A1.3.2 To qualify by tensile strength criteria, the lower tolerance limit of the 5th percentile with 75 % confidence shall be determined from the qualification sample. The analysis procedure of Practice D 2915 shall be followed.

A1.3.3 For tension laminations, the 5th percentile so determined must equal or exceed the following multiple of the allowable bending property of the target grade for which

qualification is desired: for beams over 15 in. deep-1.67, for beams 12–15 in. deep-1.50, and for beams less than 12 in. deep, 1.34.

A1.3.4 For other laminating grades, the fifth percentile shall equal or exceed the fifth percentile of the laminating grade for which replacement is sought.

A2. GLUED LAMINATED TIMBERS MANUFACTURED WITH E-RATED LUMBER

A2.1 General

A2.1.1 Glued laminated timbers may be made with *E*-rated lumber or a combination of *E*-rated lumber and visually graded lumber. For the combination of *E*-rated lumber and visually graded lumber, the visually graded lumber is commonly used in the inner zones or core, but it may be used in any location. *E* rating of lumber is accomplished by several different methods in commercial practice. For laminating, the specific requirements are included in A2.2 and A2.3.

A2.2 E-rated Requirements

A2.2.1 Any method may be used for *E* rating provided that the LSE of the lumber meets or exceeds the requirements for the specified grade mean LSE and a lower 5th percentile calculated as follows:

$$E_{05} = 0.955 E_{\text{mean}} - 0.233 \quad (\text{A2.1})$$

A2.3 Visual Grading Requirements

A2.3.1 In addition to the requirements of Section 4, edge characteristics defined as knots, knot holes, burls or distorted grain located partially or wholly at edges of wide faces must not occupy more of the cross section than indicated by the grade designation. For example, in a 2.1E-1/8 grade, the edge characteristics described above must not exceed 1/8 of the cross section.

A2.4 Designation

A2.4.1 *E*-rated lumber for laminating shall be designated by the LSE and the fraction of the cross-section at the edge that may contain the growth characteristics given in A2.3.

A3. SAMPLING OF LUMBER FOR KNOT AND MODULUS OF ELASTICITY DATA

A3.1 Data on knot properties for the grades of lumber to be used are needed in order to determine the design levels for the bending strength of members loaded perpendicular to the wide faces of the laminations (horizontally laminated members), along with compression parallel to the grain. Data on LSE of the lumber is needed in order to calculate stress distributions in beams and to determine the stiffness of the beams. Different levels of sampling are recognized for collecting these data, one during development of a laminating grade and another during the actual use of grade in production of glulam members. Guidelines for sampling material are given in Practice E 105. In addition, an alternative method of sampling is given in A3.2.2 when a limited amount of information exists for a particular species of lumber.

A3.2 Knot Data:

A3.2.1 Data Collection:

A3.2.1.1 *Development*—During the development of the laminating grade, not less than 100 pieces or 1000 lineal ft (300 m) of lumber randomly chosen from a representative group shall be used as a sample for each grade of lumber. No special selection of the pieces should be made; the only requirement is that they meet the grade but not qualify for a higher grade.

A3.2.1.2 *Confirmation*—After the laminating grade has been put in use, not less than 200 pieces of a grade or –2000 lineal ft (600 m) shall be randomly chosen in at least 20 sampling visits to glulam manufacturers representing at least 75 % of the regional production of that grade. If the grade is being used by four or less glulam manufacturers, it is recommended that at least two visits be made to collect the sample. This confirming survey shall be used to modify, if necessary,

combinations based on the development survey. A3.2.2 of this annex shall be used to evaluate the confirming knot data.

A3.2.1.3 *Use*—After the confirming survey has been made, subsequent surveys shall be conducted at least every three years. The results shall be reviewed in accordance with section C4 of this annex. Alternatively, a continuous sampling procedure may be used in which knot data are collected on a frequent, periodic basis and the accumulated data reviewed for changes sufficient to require design changes. Accumulated data shall be analyzed at intervals not exceeding two years.

A3.2.1.4 Resampling for knot data is required if knot size measurement or interpretation are changed or if design properties associated with knot data (for example, stress index values, long span *E*) are increased.

A3.2.1.5 Guidelines for measuring knots and for calculating knot properties are given in Appendix A6.

A3.2.1.6 Knot data for horizontal laminated combinations must include the average of the sum of all knot sizes within each 1-ft (0.30-m) length, taken at 0.2-ft (60-mm) intervals, and the determination of the 99.5-percentile knot size.

A3.2.1.7 Knot data for glulam combinations loaded in compression parallel to grain must include the average and the standard deviation for the largest knot size within each 3-ft (0.9-m) length taken at 0.5-ft (0.15-m) interval.

A3.2.2 *Requirements for Evaluation of New Knot Data*—New knot data is reviewed for acceptance to judge the adequacy of the new data to better represent the target populations. Where knot values are already in use, new data may be presented to substantiate, augment or replace the existing data. The following requirements must be followed in consideration of the new data. A decision sequence (see Appendix A6) is recommended.

A3.2.2.1 *Substantiation*—Where new data is demonstrably well representative of the population, but does not present significant differences stated in Appendix A6, and where existing data is fully documented and not in need of increased precision, the new data analysis may be considered for inclusion to permanent files as substantiation of the specific knot values to which it applies.

A3.2.2.2 *Augment Existing Data*—Where new data is demonstrably well representative of the population, but does not present significant differences as stated in Appendix A6, and where existing data is documented and can be shown to be in need of additional precision, the new data may be combined with existing data to result in a more precise estimate of the respective population parameters.

A3.2.2.3 *Replacement*—Before new knot data may be considered for replacement of existing data, appropriate statistical tests must show that the population was representatively sampled, and that the new data describes the population to be significantly different from the population represented in current use with respect to mean, and 99.5 percentile knot size. In the absence of the above, data may be considered for replacement on the grounds that it represents a more adequate sample or is more completely documented than existing data, or both.

A3.3 *LSE Data:*

A3.3.1 The LSE as defined in 3.1.5.1 shall be measured on each piece sampled for section A3.2 of this annex. The average and variance of LSE shall be calculated for the batch lots sampled in accordance with A3.2.1.1-A3.2.2.3. The mean and variability of LSE shall be monitored for samples taken as part of the continuous sampling provisions of A3.2.1.3.

A3.3.2 LSE data shall be collected on specimens having $12\% \pm 2\%$ MC whenever possible to minimize correction error. Data shall be corrected to 12% moisture content using Practice D 2915.

A3.3.3 LSE data may be collected on laminating grades in sampling supplement to those corresponding to A3.2. The same sampling and analysis principles shall be used. Increases in LSE identified using the evaluation principles of Appendix A7 may not be employed in 7.5 unless coincident knot data is collected and evaluated in accordance with section A3.2.

A3.3.4 An evaluation of the adequacy of existing LSE data shall be made for sampling conducted in concert with A3.2. The general principles of evaluation as outlined for knot data in A3.2 and Appendix A6 shall be used.

A3.4 *Special Provisions for Initial Development:*

A3.4.1 An alternative method of establishing knot and LSE data for initiation of laminating shall be used where ASTM clear wood properties of a species have not recently been reassessed and/or the availability of lumber data is too limited to meet the sampling criteria of A3.2.1.1. An example would be a candidate application where only non-structural grades currently exist; thus, generation of representative laminating grades may be difficult until feasibility can be demonstrated. This method requires collecting sufficient candidate lumber to permit measurement of knot frequency and LSE on each grade for preliminary layup calculations and beam tests, if necessary. A minimum of 100 pieces of lumber of each of the grades in the outer tension and compression zones is required and 50 pieces of the lumber grades used in other zones. Average length of the pieces should equal or exceed either 10 ft or the average length of the lumber intended for production.

A3.4.2 It is intended that these data will be superseded by the practices of A3.2 and A3.3 once production of glulam timber using the lumber begins. The application of this alternative is intended to be limited by elapsed time or quantity of production.

A3.4.3 The following special quality control procedures shall be during the application of these special provisions of Annex A3.

A3.4.3.1 *Qualification*—The lumber sampled in A3.4.1 shall form the basis for determining the material properties and the basis for subsequent quality control parameters. For lumber selected for beam production, knot properties and long span E shall be measured on samples sizes of lumber similar to those given in A3.4.1. Measurement of specific gravity is recommended as an additional index of wood quality during this initial phase. Knot data shall be analyzed for \bar{x} and h , both for use in the layup analysis and for subsequent use in quality control. Knot and long-span E properties of this sample shall be consistent with that developed in A3.4.1.

A3.4.3.2 *Quality Control*—Lumber shall be randomly sampled to determine wood quality during production. Knot data and LSE of these samples shall be determined; measurement and control of specific gravity is also recommended.

A3.4.4 *Reassessment*—If the quality control procedures in A3.4.3.2 indicate out-of-conformance with the sample of A3.4.1, production shall be stopped and standard procedures taken to assess production lots for conformance before resuming production. Significant changes noted in the lumber properties require reassessment of the appropriateness of the layup combination, including the initial lumber property assumptions. Quality control data may form the basis for a new set of properties to use in A3.4.1.

A4. ANALYSIS OF A GLULAM BEAM WITH THREE STIFFNESS ZONES

A4.1 Symmetric Combinations

A4.1.1 For a three-zone beam (13), the transformed section moment of inertia factor, T_i , can be expressed as:

$$T_i = \frac{(E_1 d_1^3 - d_2^3(E_1 - E_2) - d_3^3(E_2 - E_3))}{E_1 d_1^3} \quad (A4.1)$$

where:

$E_1, E_2,$ and E_3 = moduli of elasticity for the zones shown in Fig. A4.1 and

$d_1, d_2,$ and d_3 = depths shown in Fig. A4.1

A4.1.2 The calculation for the I_K/I_G ratio becomes:

$$R = \frac{1}{\sum_0^{n_1} Z} \left\{ x_1 \sum_0^{n_1} Z + \left(\frac{E_2}{E_1}\right) x_2 \sum_0^{n_2} Z + \left(\frac{E_3}{E_1}\right) x_3 \sum_0^{n_3} Z \right. \quad (A4.2)$$

$$\left. + \left[h_1^2 \sum_0^{n_1} Z^2 + \left(\frac{E_2}{E_1} h_2\right)^2 \sum_0^{n_2} Z^2 + \left(\frac{E_3}{E_1} h_3\right)^2 \sum_0^{n_3} Z^2 \right]^{1/2} \right\}$$

where:

R = I_K/I_G ,

$x_1, x_2,$ and x_3 = average knot sizes expressed in decimal fraction of the width for grades of lumber with average stiffness values of $E_1, E_2,$ E_3 , respectively,

h_1, h_2, h_3 = differences between the 99.5 percentile and average knot size in decimal fraction of the width for the respective grades,

Z, Z^2 = weighting factors from Table A4.1 and

n_1, n_2, n_3 = number of laminations in $d_1, d_2,$ and d_3 , respectively.

A4.1.3 A corresponding bending stress modification factor (SMF_b) can be determined by:

$$SMF_b = (1 + 3R)(1 - R)^3 (1 - R/2) \quad (A4.3)$$

A4.1.4 Multiplication of SMF_b by the stress index results in an allowable bending stress for outer laminations, f_1 .

A4.1.5 The intermediate beam of depth d_2 must be checked to assure that the laminations are not overstressed.

$$R = \frac{1}{\sum_0^{n_2} Z} \left\{ x^2 \sum_0^{n_2} Z + \left(\frac{E_3}{E_2}\right) x_3 \sum_0^{n_3} Z \right. \quad (A4.4)$$

$$\left. + \left[h_2^2 \sum_0^{n_2} Z^2 + \left(\frac{E_3}{E_2} h_3\right)^2 \sum_0^{n_3} Z^2 \right]^{1/2} \right\}$$

A4.1.6 An allowable stress f_2 (subject to a minimum strength ratio of the grade) can then be calculated. In order to avoid inner lamination over stresses in the depth d_2 ,

$$f_2 \geq \left(\frac{d_2}{d_1}\right) \left(\frac{E_2}{E_1}\right) f_1 \quad (A4.5)$$

A4.1.7 Finally, the inner beam of depth d_3 must be checked for overstress.

$$R = \frac{1}{\sum_0^{n_3} Z} \left[x_3 \sum_0^{n_3} Z + h_3 \left(\sum_0^{n_3} Z^2 \right)^{1/2} \right] \quad (A4.6)$$

$$= x_3 + h_3 \frac{\left[\sum_0^{n_3} Z^2 \right]^{1/2}}{\sum_0^{n_3} Z}$$

A4.1.8 An allowable stress f_3 is calculated next in order to avoid inner lamination over stresses in depth d_3 .

$$f_3 \geq \left(\frac{d_3}{d_1}\right) \left(\frac{E_3}{E_1}\right) f_1 \quad (A4.7)$$

A4.1.9 If f_2 and f_3 are less than the quantity calculated for the right side of the equation, f_1 is limited to a value that will satisfy an equality. For use with properties of the actual physical section, f_1 can be multiplied by T_i to yield a value of f . Also, for use with the original moment of inertia, I , the value of E_1 must be multiplied by T_i to yield a design value, E .

$$f = f_1 T_i \quad (A4.8)$$

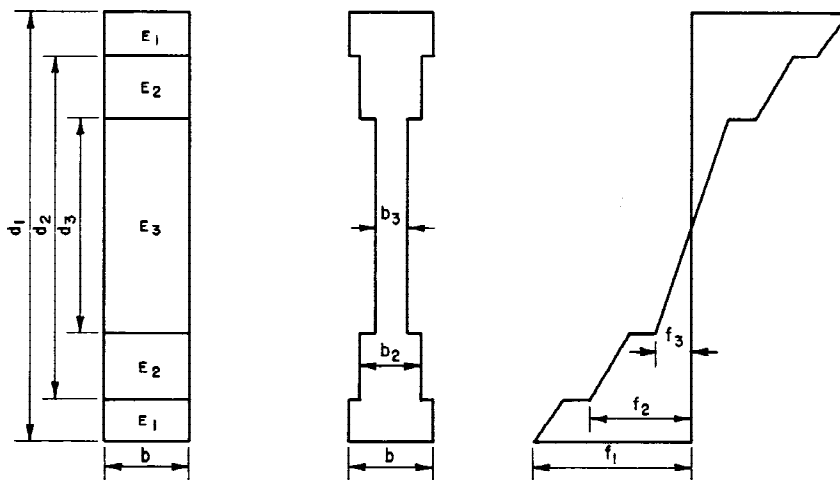

FIG. A4.1 Beam with Three Stiffness Zones

TABLE A4.1 Factors for Use in Computing Values of I_k/I_G from Characteristics of Knot Distributions^A

Number of Lamination = 2N	Weighting Factor for Nth Lamination from Neutral Axis Z = 3N ² - 3N + 1 = N ³ - (N - 1) ³	For 2N Laminations		Z ² /Z
		$\Sigma Z = 2N^3$	$\Sigma Z^2 = 2/5[N(9N^4 - 5N^2 + 1)]$	
1	1/4	1/4	1/16	1.000
2	1	2	2	0.707
3	3 1/4	6 3/4	21 3/16	0.682
4	7	16	100	0.625
5	12 1/4	31 1/4	321 5/16	0.573
6	19	54	822	0.531
8	37	128	3 560	0.466
10	61	250	11 002	0.420
12	91	432	27 564	0.384
14	127	686	59 822	0.357
16	169	1 024	116 944	0.334
18	217	1 458	211 122	0.315
20	271	2 000	358 004	0.299
22	331	2 662	577 126	0.285
24	397	3 456	892 344	0.273
26	469	4 394	1 332 266	0.263
28	547	5 488	1 930 684	0.253
30	631	6 750	2 727 006	0.245
40	1 141	16 000	11 504 008	0.212
50	1 801	31 250	35 125 010	0.190

^A From Ref 6.

$$E = E_1 T_i$$

A4.2 Unsymmetric Combinations

A4.2.1 For unsymmetric combinations, the neutral axis must first be located. The procedure is to then analyze the compression and tension sides independently as half of symmetric beams. For the compression side, stresses 40 % higher than the tension side may be permitted without changing the near minimum strength.

A4.3 Example: Analysis of a 20-Lamination Glulam Beam

A4.3.1 *Given*, a 20-lamination symmetric beam shown in Fig. A4.2(a) consisting of two L1 and four L2 Douglas fir outer laminations, and eight L3 grade lodgepole pine inner laminations.

A4.3.2 *Determine* the allowable bending stress.

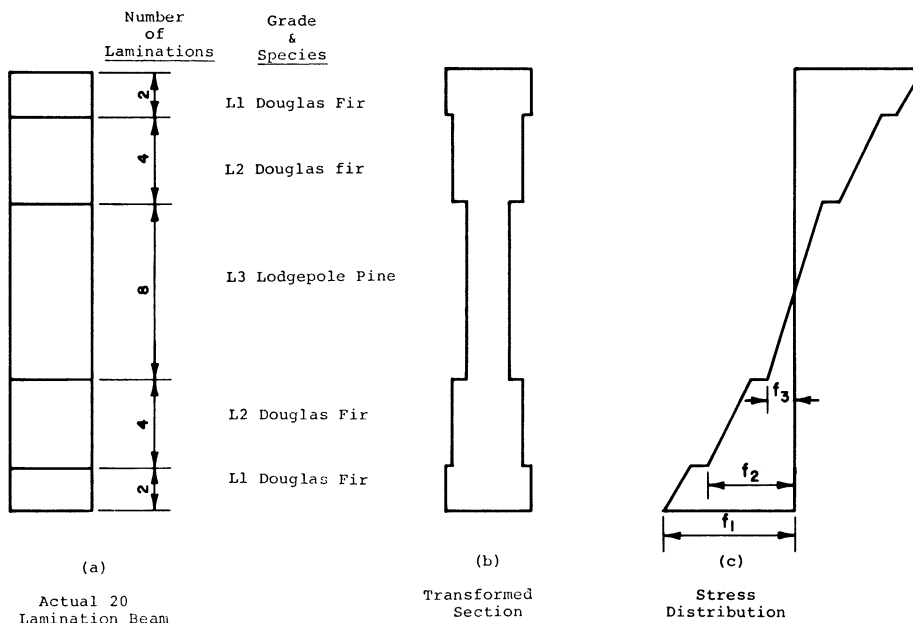

FIG. A4.2 Analysis of 20-Lamination Beam

A4.3.3 *Required Data:* Modulus of elasticity, bending stress index, and knot data for the three grades of lumber. These values along with the source of information are given in Table A4.2.

A4.3.4 *Procedure:*

A4.3.4.1 Calculate the transformed section moment of inertia factor, T_i , for the simulated I-beam shown in Fig. A4.2(b) as follows:

$$T_i = \frac{2.1(20^3) - \{(2.1 - 1.8)(16^3)\} - \{(1.8 - 1.1)(8)^3\}}{2.1 \times 20^3} = 0.906 \quad (A4.9)$$

A4.3.4.2 Determine I_K/I_G ratio (R) and bending stress modification factor (SMF_b) of whole beam as follows:

$$R = \frac{1}{\sum Z_{20}} \left\{ (0.069)(Z_{20} - Z_{16}) + (0.109) \left(\frac{1.8}{2.1} \right) \cdot (Z_{16} - Z_8) + (0.230) \left(\frac{1.1}{2.1} \right) (Z_8) + \left[(0.353)^2 (Z_{20}^2 - Z_{16}^2) + \left(0.440 \times \frac{1.8}{2.1} \right)^2 \cdot (Z_{16}^2 - Z_8^2) + \left(0.558 \times \frac{1.1}{2.1} \right)^2 Z_8^2 \right]^{1/2} \right\} = \frac{1}{2000} \left\{ (0.069)(2000 - 1024) + (0.109) \left(\frac{1.8}{2.1} \right) \cdot (1024 - 128) + (0.230) \left(\frac{1.1}{2.1} \right) (128) + \left[(0.353)^2 (358\,004 - 116\,944) + \left(0.440 \times \frac{1.8}{2.1} \right) (116\,944 - 3560) + \left(0.558 \times \frac{1.1}{2.1} \right)^2 (3560) \right]^{1/2} \right\} = 0.191$$

$$SR_b = (1 + 3 \times 0.191)(1 - 0.191)^3 \left(1 - \frac{0.191}{2} \right) = 0.753 \quad (A4.11)$$

A4.3.4.3 Calculate allowable outer fiber stress as follows (see Fig. A4.2(c)):

$$\text{Allowable } f_1 = 0.753 \times 3500 = 2640 \text{ psi} \quad (A4.12)$$

A4.3.4.4 Determine I_K/I_G ratio (R) and bending stress modification factor (SMF_b) of 16-lamination intermediate beam as follows:

$$R = \frac{1}{\sum Z_{16}} \cdot \left\{ (0.109) \times (Z_{16} - Z_8) \right\}$$

$$+ (0.230) \left(\frac{1.1}{1.8} \right) (Z_8) + \left[(0.440)^2 (Z_{16}^2 - Z_8^2) + \left(0.558 \times \frac{1.1}{1.8} \right)^2 Z_8^2 \right]^{1/2} \} = 0.259 \quad (A4.13)$$

$$SMF_b = (1 + 3 \times 0.259)(1 - 0.259)^3 \left(1 - \frac{0.259}{2} \right) = 0.629$$

A4.3.4.5 Calculate allowable fiber stress at interface between L1 and L2 material as follows:

$$\text{Allowable } f_2 = 0.629 \times 3000 = 1890 \text{ psi}$$

A4.3.4.6 Determine I_K/I_G ratio (R) and bending stress modification factor (SMF_b) for 8-lamination inner beam as follows:

$$R = \frac{1}{\sum Z_8} \left\{ (0.230)(Z_8) + [(0.558)^2 (Z_8)^2]^{1/2} \right\} = 0.490 \quad (A4.14)$$

$$SMF_b = (1 + 3 \times 0.490)(1 - 0.490)^3 \left(1 - \frac{0.490}{2} \right) = 0.2472 < 0.50$$

Assume $SR_b = 0.50$ because largest knots permitted in L3 grade are 50 % of cross section.

A4.3.4.7 Calculate allowable fiber stress at interface between L2 and L3 material as follows:

$$\text{Allowable } f_3 = 0.500 \times 1933 = 970 \text{ psi} \quad (A4.15)$$

A4.3.4.8 Determine which of calculated stresses control as follows:

$$f_2 > \frac{1.8}{2.1} \times \frac{8}{10} \times f_1 = 24/35 f_1 = 1810 \text{ psi} \quad (A4.16)$$

$$\text{Allowable } f_2 = 1890, f_1 \text{ controls.}$$

$$\text{Actual } f_3 > \frac{1.1}{2.1} \times \frac{4}{10} \times f_1 = 550 \text{ psi}$$

but

$$\text{Allowable } f_3 = 970, f_1 \text{ controls.}$$

Therefore,

$$\text{Allowable } f_1 = 2640\text{-psi controls.}$$

A4.3.4.9 Determine allowable combination bending stress and modulus of elasticity as follows:

TABLE A4.2 Lumbar Data for Analysis of Glulam Beam Bending Stress

Grade and Species ^A	Modulus of Elasticity ^B		Bending Stress Index ^C		Knot Data ^D		
					x	99.5 Percentile	h
	psi	MPa	psi	MPa	%	%	%
L1 Douglas fir	2 100 000	14 500	3500	24.1	6.9	42.2	35.3
L2 Douglas fir	1 800 000	12 400	3000	20.7	10.9	54.9	44.0
L3 Lodgepole pine	1 100 000	7 600	1933	13.3	23.0	78.8	55.8

^A Graded in accordance with WWPA and WCLIB rules under the American Lumber Standard. (Refs 2 and 3) L3 lodgepole pine graded under rules for L3 Douglas fir.

^B Based on 7.5.1.1 for Douglas fir and 6.1.5.1 and 7.5.1 for lodgepole pine.

^C Based on 6.1.1.1 for Douglas fir and 6.1.1 for lodgepole pine.

^D Based on 5.1.2 for Douglas fir and 5.1.1 for lodgepole pine.



$$f = 2640 \times 0.906 = 2390 \text{ psi} \approx 2400 \text{ psi.} \quad (\text{A4.17})$$

$$E = 2.1 \times 0.906 \times 0.95 = 1.81 \times 10^6 \text{ psi} \approx 1.8 \times 10^6 \text{ psi.}$$

A4.3.4.10 Determine outer 5 % tension lamination requirement (see 12.2.3.1.)

Required strength ratio:

$$SR_{t1} = 2400/0.906/3500 = 2650/3500 = 0.757 \quad (\text{A4.18})$$

Edge knot plus grain deviation:

$$GDS \leq 1.55(1 - SR_{t1}) \quad (\text{A4.19})$$

$$GDS = 1.55(1 - 0.757) = 0.38$$

Therefore edge knot plus grain deviation limited to 0.35 (rounded to next lower 0.05) for outer tension lamination.

Centerline knot plus grain deviation:

$$GDS \leq 1.82(1 - SR_{t1}) \quad (\text{A4.20})$$

$$GDS = 1.82(1 - 0.757) = 0.44$$

Therefore centerline knot plus grain deviation limited to 0.40 for outer tension lamination.

A4.3.4.11 Determine next 5 % tension lamination requirement (see 12.2.3.2).

Edge knot:

$$KE = 0.66 - 0.45(0.757) = 0.32 \quad (\text{A4.21})$$

Therefore, edge knot limited to 0.30 (L1 permits up to 0.25 knot) for next inner tension lamination.

Centerline knot:

$$KC = 1.20 - 0.93(0.757) = 0.50 \quad (\text{A4.22})$$

Therefore centerline knot limited to 0.50 for next inner tension lamination.

A4.3.4.12 Determine slope of grain requirements for all laminations. The bending stress modification factor is determined as follows:

$$SMF = \text{maximum actual stress/bending stress index} \quad (\text{A4.23})$$

$$SMF = (2400/0.906)/3500 = 0.757$$

From Table 4, outer tension lamination requires a slope of grain of 1:16. Outer compression lamination requires a slope of grain of 1:12. Suitable for top two laminations as L1 has a slope of grain of 1:14. The outer surface of the second lamination is 0.9 of the distance from the neutral axis to outer face of the member. Second tension lamination stress modification factor:

$$SMF = 0.9 \times 0.757 = 0.681 \quad (\text{A4.24})$$

1:12 slope of grain required, 1:14 per grade is suitable.

L2 zone stress modification factor

$$= 2400/0.906 \times 1.8/2.1 \times 0.8 \div 3000 = 0.605$$

Tension side needs a slope of grain of 1:10, 1:12 per grade; all L2 suitable.

L3 zone stress modification factor

$$= 2400/0.906 \times 1.1/2.1 \times 0.4 \div 1933 = 0.287$$

Tension side needs a slope of grain of 1:6, 1:8 per grade; all L3 suitable. Slope of grain requirement of all lamination grades are adequate except outer tension lamination which needs a slope of grain of 1:16.

A5. PROCEDURE FOR DETERMINING DESIGN STRESSES IN COMPRESSION PARALLEL TO GRAIN

A5.1 Procedural Steps

A5.1.1 Determine the transformed area factor, T_a , as follows:

$$T_a = \frac{\sum_{k=1}^n E_k A_k}{E_1 \sum_{k=1}^n A_k} \quad (\text{A5.1})$$

where:

n = total number of laminations,

E_k = long-span modulus of elasticity of k -th lamination,

A_k = actual (untransformed) cross-sectional area occupied by k -th lamination, and

E_1 = long-span modulus of elasticity of outermost lamination on the bottom face.

A5.1.2 Using values of the average (m_k) and the standard deviation (σ_k) knot size determined in accordance with 5.3 for the respective laminations, calculate values for composite average knot size (m_c) and composite standard deviation knot size (σ_c) for the combination as follows:

$$m_c = \frac{\sum_{k=1}^n (E_k A_k m_k)}{E_1 \sum_{k=1}^n A_k} \quad (\text{A5.2})$$

$$\sigma_c = \frac{\left\{ \sum_{k=1}^n (E_k^2 A_k^2 \sigma_k^2) \right\}^{1/2}}{E_1 \sum_{k=1}^n A_k} \quad (\text{A5.3})$$

For glulam members made with single-grade laminations, Eq A5.3 can be reduced to:

$$\sigma_c = \frac{s}{n^{1/2}} \quad (\text{A5.4})$$

where:

n = total number of laminations, and

s = standard deviation knot size for the laminations in accordance with 5.3 ($s = \sigma_1 = \sigma_2 = \dots = \sigma_k$).

A5.1.3 Compute the composite knot size at the 99.5 percentile, Y_1 , as follows:

ASTM D 3737 – 02

$$Y_1 = m + 2.576 \sigma \quad (A5.5)$$

where m , σ , and Y_1 are expressed in decimal fractions of the width of the dressed size of lumber used for a lamination.

A5.1.4 Compute the stress modification factor from Eq 4 (see 7.3.2) and compare with that determined by the slope of grain for each grade.

A5.1.5 Calculate the allowable compressive stress on the actual combination for each grade at the interface between grades as follows:

$$f_c = S_{l_c} \times SMF_c \quad (A5.6)$$

where:

- f_c = allowable compressive stress,
- S_{l_c} = stress index in compression, and
- SMF_c = stress modification factor in compression (Eq 4 in 7.3.2).

A5.1.6 For unsymmetric combinations, calculate relative stress factors for each interface as follows:

$$S_i = \left(\frac{E_j}{E_1} \right) \left[\left(\frac{1}{T_a} \right) \pm \left(\frac{12a}{T_i d_1^2} \right) x_i \right] \quad (A5.7)$$

where:

- S_i = relative stress factor at the i -th interface,
- E_j = long-span modulus of elasticity of laminations in j -th zone ($j = i - 1$),
- E_1 , and T_a = as defined in Eq A5.1,
- T_i = transformed moment of inertia factor (see Eq A2.1),
- a = shift in the neutral axis from midheight,
- d_1 = beam depth, and
- x_i = distance from neutral axis to the i -th interface.

The sign plus (+) or minus (-) depends upon whether the induced bending stress is compressive or tensile, respectively. For symmetric combinations, $S_i = E_j / (E_1 T_a)$.

A5.1.7 Combination for f_c is lowest of all f_{ci} / S_i .

A5.2 Example—Analysis of an Eight-Lamination Member

A5.2.1 Given—An eight-lamination compression member as shown in Fig. A5.1, lumber properties as shown in Table A5.1 and the following data:

$$T_i = 0.845$$

$$a = 0.120$$

$$d_1 = 8$$

A5.2.1.1

$$T_a = \frac{2.1(1) + 1.9(1) + 0.8(4) + 1.8(2)}{2.1(8)} = 0.643$$

A5.2.1.2

$$m_c = \frac{2.1(1)(0.2) + 1.9(1)(0.35) + 0.8(4)(0.45) + 1.8(2)(0.35)}{2.1(8)} = 0.225$$

$$\sigma_c = \frac{\left\{ \begin{aligned} &(2.1)^2(1)^2(0.10)^2 + (1.9)^2(1)^2(0.15)^2 \\ &+ (0.8)^2(1)^2(0.20)^2 + (0.8)^2(1)^2(0.20)^2 \\ &+ (0.8)^2(1)^2(0.20)^2 + (0.8)^2(1)^2(0.20)^2 \\ &+ (1.8)^2(1)^2(0.15)^2 + (1.8)^2(1)^2(0.15)^2 \end{aligned} \right\}^{1/2}}{(2.1)(8)}$$

$$= \frac{\left\{ \begin{aligned} &(2.1)^2(1)^2(0.10)^2 \\ &+ (1.9)^2(1)^2(0.15)^2 \\ &+ (4)(0.8)^2(1)^2(0.20)^2 \\ &+ (2)(1.8)^2(1)^2(0.15)^2 \end{aligned} \right\}^{1/2}}{(2.1)(8)} = 0.0364$$

A5.2.1.3

$$Y_1 = 0.225 + 2.576 \times 0.0364 = 0.319$$

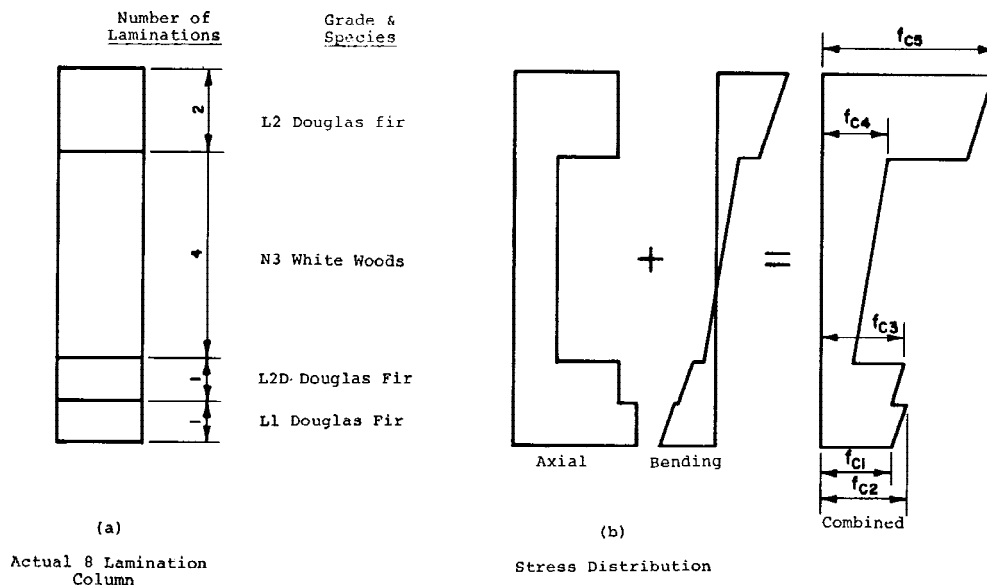

FIG. A5.1 Axially Loaded Member with Unsymmetric Grades



TABLE A5.1 Number Data for Analysis of Compression Parallel to Grain Stress

Grade and Species	Modulus of Elasticity	Compression Stress Index		Knot Data ⁴	
				m	σ
	million-psi	psi	MPa		
L1 Douglas fir	2.1	2 780	19.2	0.20	0.10
L2D Douglas fir	1.9	2 780	19.2	0.35	0.15
L2 Douglas fir	1.8	2 380	16.4	0.35	0.15
N3 white wood	0.8	1 330	9.2	0.45	0.20

⁴ Estimated parameters.

A5.2.1.4 Determine SMF_c for knots and slope of grain as follows:

$$SMF_c = \frac{(0.319)^3}{4} - (0.319)^2 - \frac{0.319}{4} + 1$$

$$= 0.827$$

According to Table 4:

1:14 Slope of grain of L1 limits SMF_c to 0.87.

1:12 Slope of grain of L2 limits SMF_c to 0.82.

1:4 Slope of grain of N3 limits SMF_c to 0.46.

A5.2.1.5 Calculate allowable stresses using stress indexes shown in Table A5.1 as follows:

$$f_{c1} < f_{c2}$$

$$f_{c2} = 0.827 \times 2780 = 2300 \text{ psi}$$

$$f_{c3} = 0.82 \times 2780 = 2280 \text{ psi}$$

$$f_{c4} = 0.46 \times 1330 = 610 \text{ psi}$$

$$f_{c5} = 0.82 \times 2380 = 1950 \text{ psi}$$

A5.2.1.6 Calculate relative stress factors as follows:

$$S_2 = \frac{2.1}{2.1} \left[\frac{1}{0.643} - \frac{12(0.120)}{0.845(64)} (2.88) \right]$$

$$= 1.555 - 0.0266 (2.88)$$

$$= 1.478$$

$$S_3 = \frac{1.9}{2.1} [1.555 - 0.0266(1.88)] = 1.362$$

$$S_4 = \frac{0.8}{2.1} [1.555 + 0.0266(2.12)] = 0.614$$

$$S_5 = \frac{1.8}{2.1} [1.555 + 0.0266(4.12)] = 1.427$$

A5.2.1.7 Determine which f_c is the lowest of $f_{c_{ix}} / S_{ix}$. Lowest is $f_{c4} / S_4 = 990$ psi. Therefore, $f_c = 990$ psi, or 1000 psi (rounded to nearest 50 psi).

A6. GUIDELINES FOR DETERMINING ACCEPTANCE OF NEW KNOT DATA

A6.1 In order to establish a knot survey data base for a laminating lumber grade, all knots in individual pieces of lumber selected from a representative sample of the material (see Annex C) shall be physically measured (mapped) to determine the % of the cross-section of the piece occupied by each knot based on a displacement technique. Knots shall be identified in accordance with the accompanying sketches. Knots shall be identified as Types 1–9 with various sub-categories further defined within the basic knot type. It is noted that there is no knot Type 8. All knots greater than 3/8 in. (6 mm) (equivalent cylindrical cross-section) shall be measured.

A6.2 Each knot shall be initially recorded using a longitudinal measurement, the “x” distance, from a reference position (one end of the piece being measured) and the physical size of the knot. The “x” distance is the length from the end of the piece to the position of the cross section through the center of the knot. The physical size of the knot is recorded by measurements from a reference edge of the piece. Dimensions to each edge (intersection point) of the knot on each surface (face) where the knot occurs are recorded to accurately determine the size of the knot. When a knot radiates out from the pith center, the location of the pith center is recorded (see knot Type 7 for a diagram indicating pith centers). The faces of the piece shall be identified as follows for recording purposes:

T Top (wide face) T1 and T2

B Bottom (wide face) B1 and B2
 Z Near face (narrow edge that is the reference edge) Z1 and Z2
 F Far face (narrow edge) F1 and F2
 P1 Pith Center (dimension through the thickness of the piece)
 P2 Pith Center (dimension along the wide face)

A6.2.1 See Figs. A6.1–A6.10 for each type of knot and associated measurements. Note that there purposely is no knot Type 8.

A6.2.2 Knots are recorded systematically with the knot closest to the reference end recorded first. Two measurements are recorded for each face or edge. When the knot is not visible on a face or edge, zero is recorded for the measurements for that surface. For example, a Type 1 (cylindrical knot) will have measurements for T1, T2, B1, and B2. Zeros are recorded for all other measurements. A Type 7 (pith center knot) may have measurements for any of the faces in addition to the P1 and P2 measurements that locate the pith center. When more than one knot occurs at the same “x” distance, each knot will have the same “x” measurement recorded together with the other corresponding measurements for the knot. Multiple knots at the same cross section will require separate entries on the data form.

A6.3 Calculation

A6.3.1 Knot X-bar and h values computed by these methods are based on the principles presented in USDA Technical Bulletin 1069 (6). The value, X-bar, is defined as the average

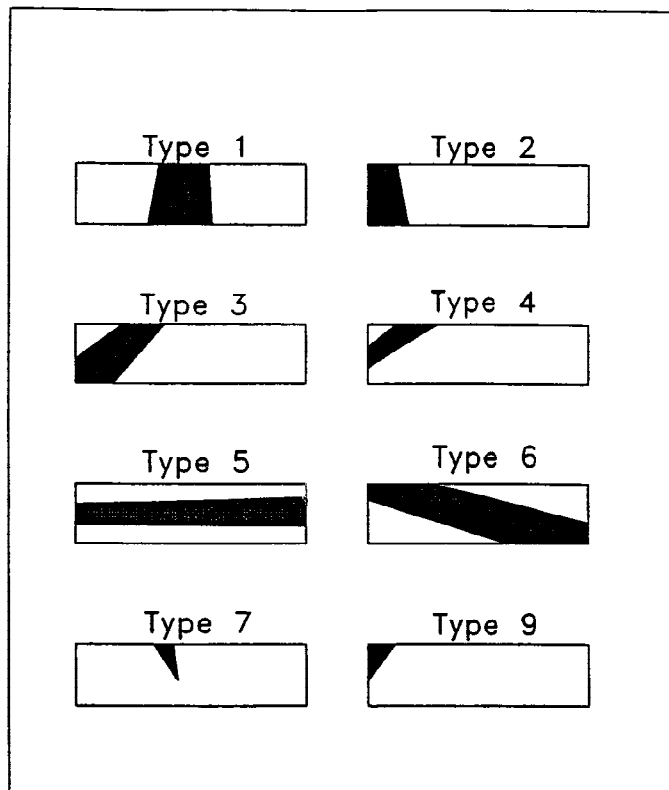

NOTE 1—Minimum knot size = 3/8 in.

FIG. A6.1 Knot Types

of the sum of all knot sizes within any 1-ft length along the piece of lumber, whereas, the value, h , is defined as the 99.5 percentile knot size. Computer programs may be employed to determine these knot properties from a knot survey data base. The following general procedures shall be incorporated in such a program to determine the values of \bar{X} and h .

A6.3.2 Any linear regression routine that determines the parameters of the regression line and the value of the 99.5 percentile shall emulate the procedure of plotting the sum of knots cumulative frequency data on arithmetical probability paper and drawing a straight line through the data which was the method used in USDA Bulletin 1069. The underlying assumption for using this procedure is that an analysis, which handles the knot data as normally distributed is satisfactory. USDA Bulletin 1069 determines cumulative frequency by dividing cumulative number of knots up through the knot size of interest by the total number of knots. This results in the maximum knot size having a cumulative frequency on the probability scale is at infinity and cannot be shown on the graph. An alternative is to calculate cumulative frequency in the same manner except 0.5 is subtracted from the cumulative total for each knot size before dividing by the total number of knots to avoid having infinity as the value for plotting the cumulative frequency of the largest knot.

A6.3.3 Two possible options for the selection of the knot size range over which to calculate the linear regression are as follows:

A6.3.3.1 One option is to calculate regressions for all knot ranges possible using as the lowest point the first point above

the average real knot size (“real” knots are all those knots that have a size greater than zero), and each of the points above the 99.5 percentile as the highest point. The regression having the least standard error of estimate is selected for the calculation \bar{X} and h for the data set.

A6.3.3.2 Another option is to use the first and last knot data points over which to calculate a linear regression for purposes of determining the 99.5 percentile sum of knots size. Knot sizes are presented as number of 1/8ths of inches equivalent diameter. These regression curves typically are plotted with the Y-axis (vertical) of the graph as knot diameter (size) in number of 1/8ths of inches and the X-axis (horizontal) as cumulative frequency as percent using an arithmetical probability scale. All the data points are shown on the graph. The left most point is for the sum of knots of 1/8ths size and the right most point is for sum of knots of the largest size in the data. A vertical line for the 99.5 percentile is plotted on the graph so the intersection of this line with the regression line can be observed.

A6.3.3.3 The selection of the regression line by using the minimum standard error of estimate gives the line with the closest fit of the data, and thus, the best estimate of the 99.5 % value.

A6.4 Acceptance

A6.4.1 *General*—A proposal for replacement of existing knot data shall include adequate statistical analyses and information to determine if the new data substantiates retaining existing data, augments existing data, or replaces existing data.

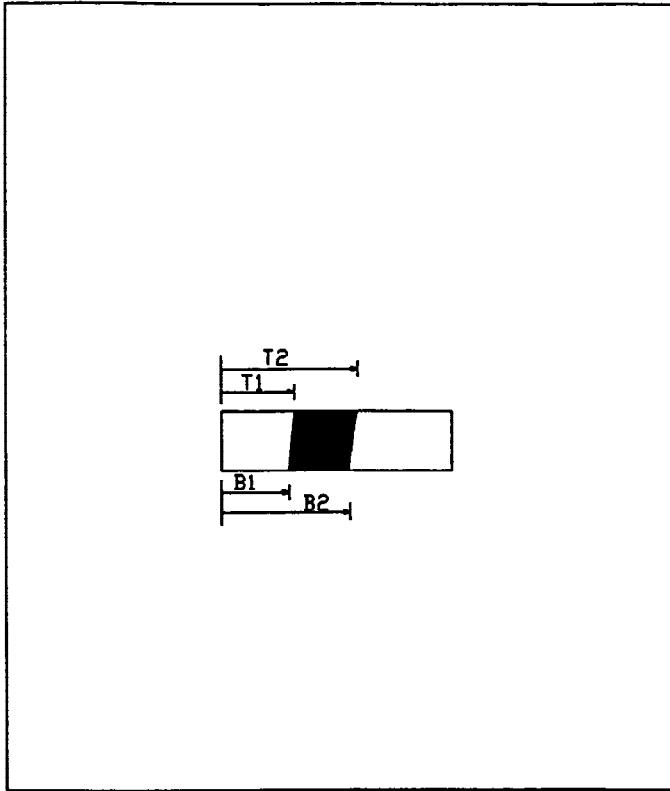

FIG. A6.2 Type 1

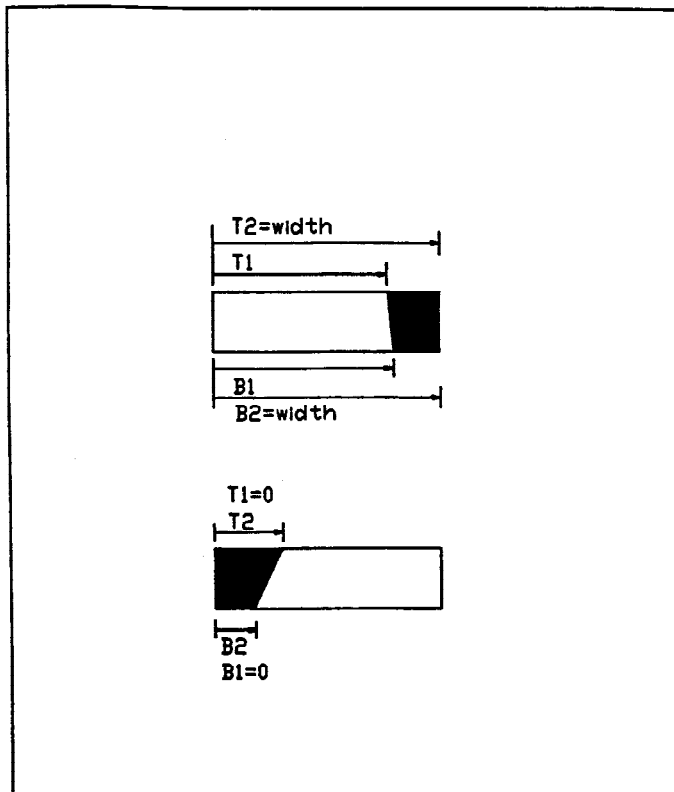

FIG. A6.3 Type 2

A6.4.2 *Statistical Comparison*—Statistical comparison of the new and existing data consists of a three-step process:

A6.4.2.1 Conduct a joint probability test for means and variances.

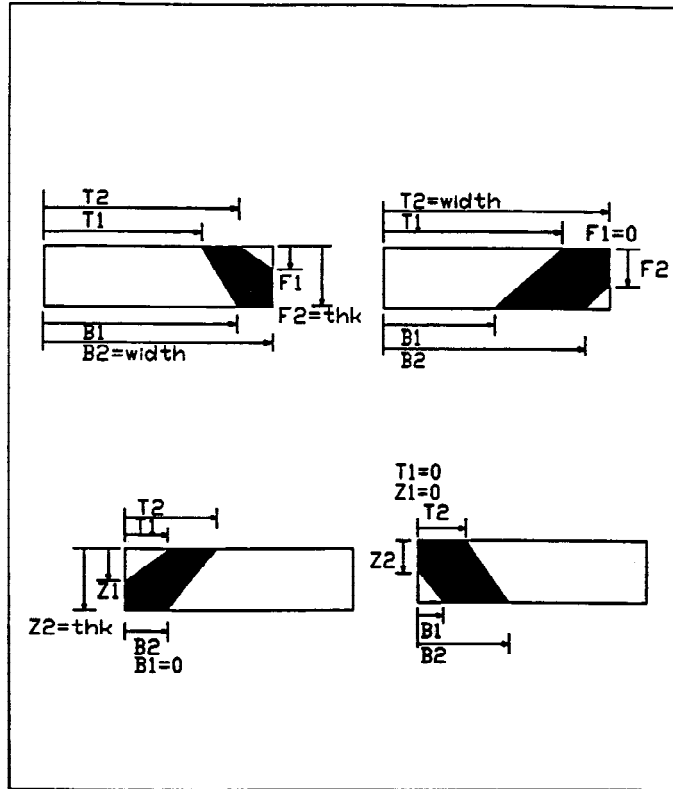

FIG. A6.4 Type 3

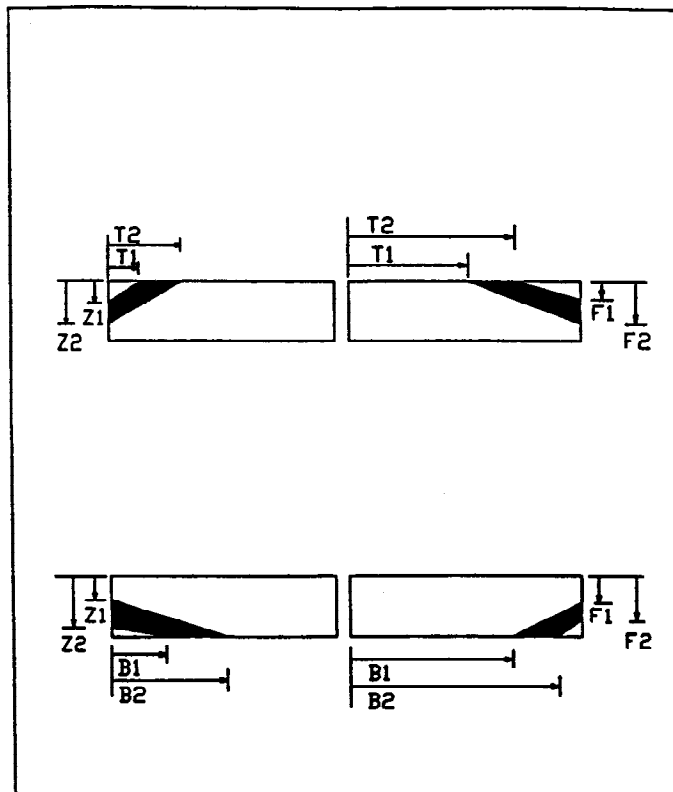

FIG. A6.5 Type 4

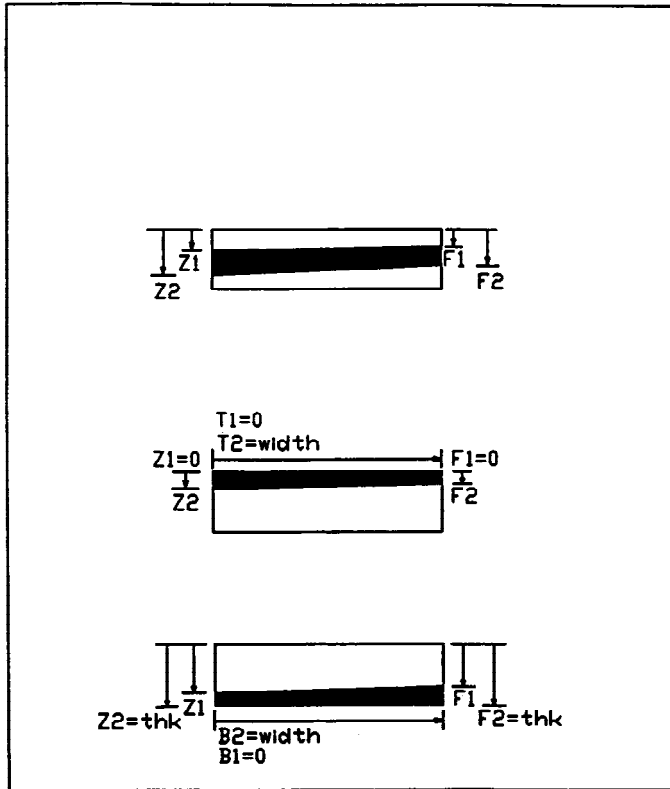

FIG. A6.6 Type 5

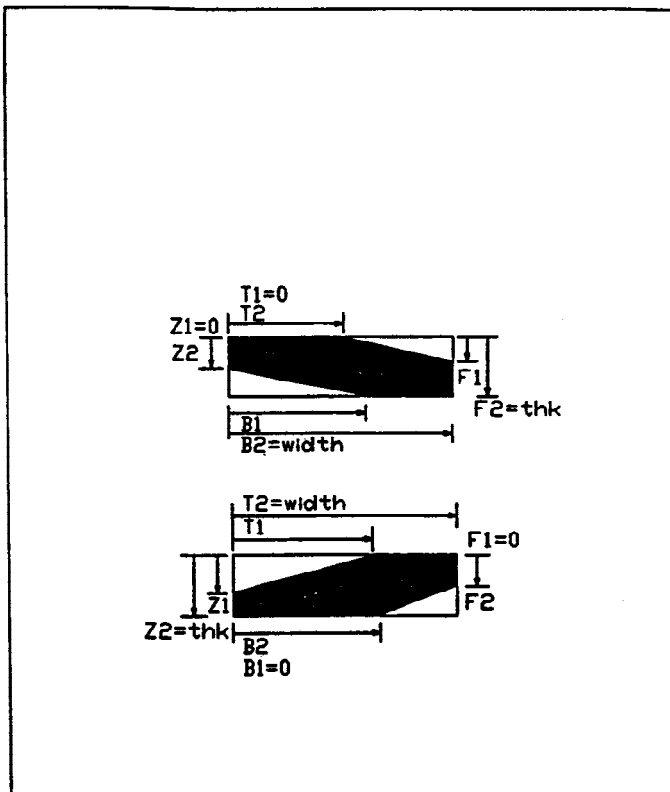
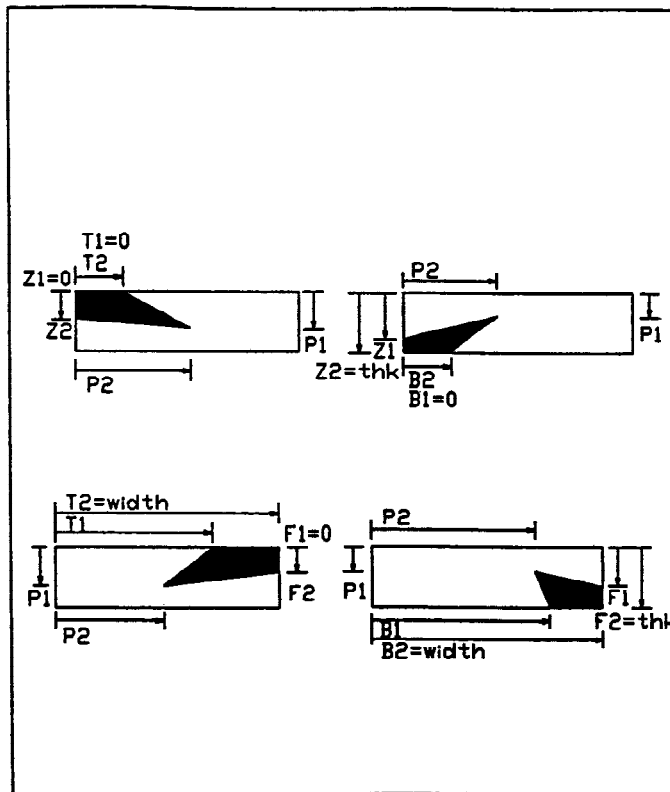
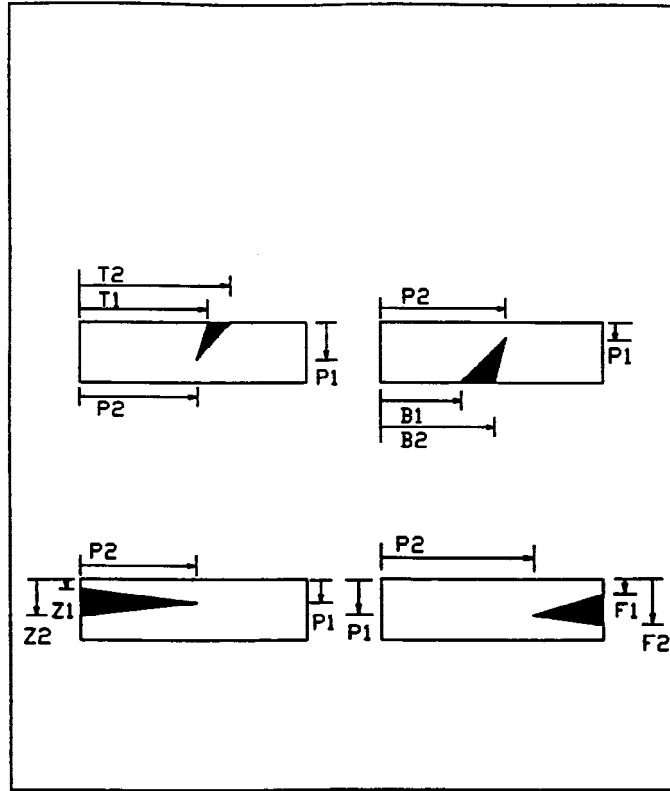

FIG. A6.7 Type 6



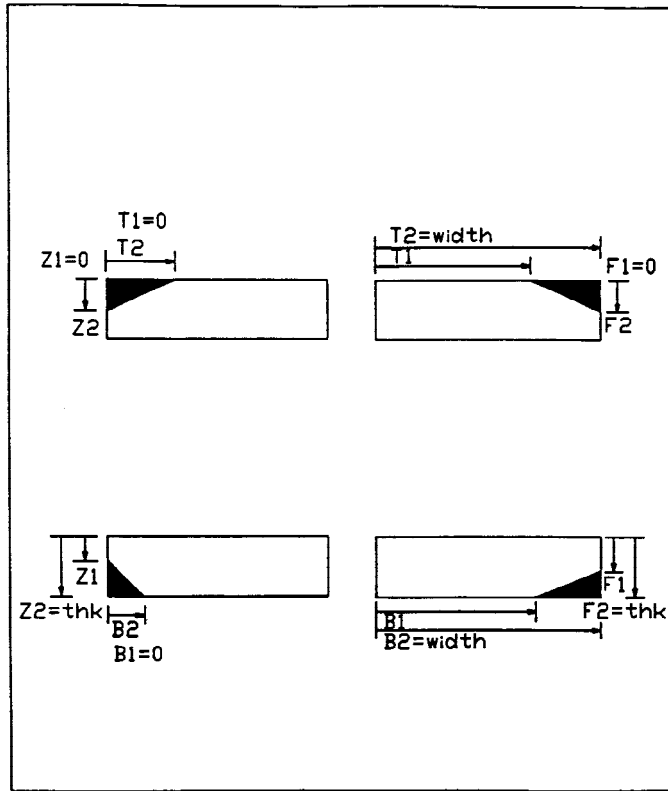

FIG. A6.10 Type 9

A6.4.2.2 Conduct an equivalency test for the quantities (usually 99.5 percentile).

A6.4.2.3 If necessary, conduct tests of distribution fit.

A6.4.2.4 *Decision Procedure*—Based on the results of A4.3.4.4, take action based on a sequence of analysis and decision such as the one in Table A6.1.

TABLE A6.1 Example Decision Sequence Composed of Analysis and Subsequent Decisions

Means and Variances	Quantile	Action
1. Unequal	Unequal	Accept new data as different from existing data; apply "practical significance" tests. Examine distribution fit. (a) If normal, consult power table to make sure sample is large enough. If it is large enough, accept new data and apply "practical significance" tests. If not large enough, take additional samples. (b) If not normal, go to 4b.
2. Unequal	Equal	
3. Equal	Equal	No changes in knot data. Examine distribution fit. (a) If normal, accept new data, apply "practical significance" test. (b) If not normal, seek help of competent statistician.
4. Equal	Unequal	

A7. TEST SETUP AND DATA ANALYSIS PROCEDURE FOR DETERMINING HORIZONTAL SHEAR STRESS BY FULL SCALE BEAM TESTS

A7.1 *Test Method*—A two-point load method, as shown in Fig. A7.1, shall be used to test all specimens. The test apparatus, including rocker-type reaction supports, reaction bearing plates and rollers, load bearing blocks, load bearing rollers, and chord length and radius of curvature of the curved load bearing blocks shall follow Test Methods D 198. When unavoidable, exceptions to Test Methods D 198 and the requirements of this annex shall be documented.

A7.1.1 The clear distance between the edge of the bearing plate to the edge of the nearest load bearing block shall be at least two times the specimen depth. The minimum width of the specimen shall be 6 in. (nominal) and the minimum depth shall be approximately 18 in. (net). The clear distance indicated is regarded as critical to prevent the shear stress distribution from being influenced by the compression perpendicular to grain stress. The bearing length should be sufficient to avoid bearing failure, but not greater than the beam depth. All specimens are to be cut to the exact length with no overhangs allowed. Load is to be applied at a constant rate so as to reach the ultimate load in about 10 min. Ref (14) provides a detailed example of a typical test setup. All failure modes shall be recorded to permit the use of either a censored or uncensored data set analysis as discussed in A7.2. A shear failure is one that fails along the length of the member in the approximate mid-depth

area of the beam and is not precipitated by a typical bending failure mode which usually starts in the bottom tension lamination.

A7.2 *Beam Manufacture*—All test beams shall be manufactured with on-grade laminating lumber representative of the grade and species being evaluated used in the critical core area of the beam where maximum shear stresses will be observed during testing. It is permissible to use a higher grade of laminating lumber than may be required in the critical tension zone of the beam to minimize typical bending mode failures and maximize the number of shear failures. End joints shall be avoided whenever possible in the critical tension laminations of the test beams.

A7.3 *Analysis Methods*—The shear (f_v) stresses at the time of specimen failure shall be calculated using the following equation:

$$f_v = \frac{3 P_{ult}}{4 b h} \quad (A7.1)$$

where:

- f_v = shear stress, psi
- P_{ult} = ultimate total load, lbf,

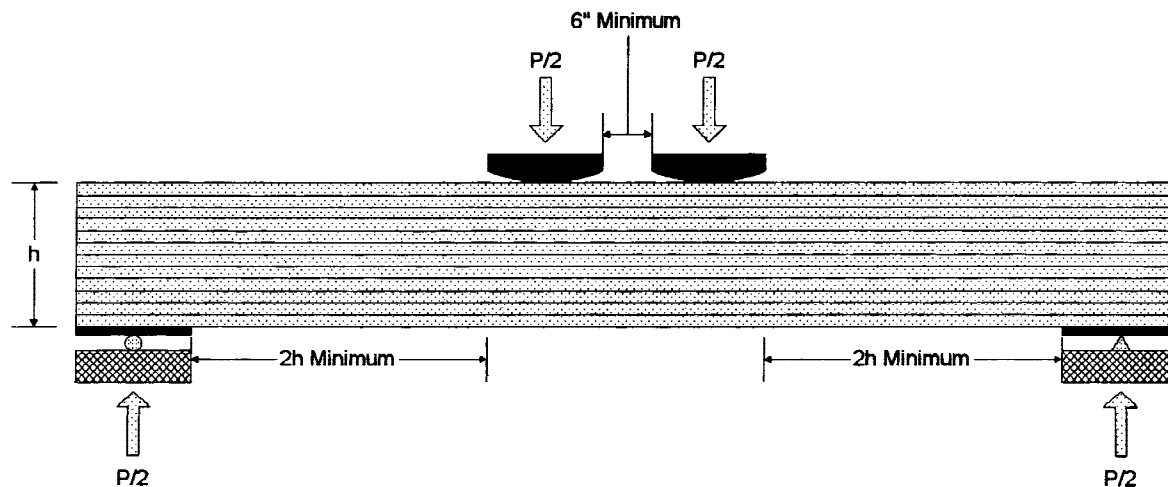

FIG. A7.1 Test Setup Based on Test Methods D 198 (not drawn to scale)

b = measured beam width, in., and
 h = measured beam depth, in.

A7.3.1 If the specimens are not pre-conditioned to a standard moisture content level of 12 % prior to testing, which may not be feasible depending on the size of the test specimens, the calculated shear stress shall be adjusted to the 12 % moisture content condition using the procedures given in Practice D 2915.

A7.3.2 The test data may be analyzed based on those data due to shear failures only (uncensored data) and those data obtained from all failure modes combined (censored data) for each species and tested widths. The data set shall have a minimum of 28 shear failures as defined in A7.1. As an example, a detailed analysis on the shear strengths of Douglas fir, southern pine, and spruce-pine-fir glulam using both censored and uncensored data sets can be found in Ref (14). In either case, a lower 5th percentile tolerance limit with 75 % confidence shall be determined.

A7.3.3 For the censored data analysis, the uncensored mean and standard deviation can be estimated by using the methodology for the maximum likelihood estimators (MLEs), as described in Lawless (Ref (15)). The estimates of the uncensored statistics from the censored data are critical due to the fact that although the uncensored mean is expected to be higher than the mean based on the censored data, the standard

deviation might be also higher. As a result, the lower 5th percentile tolerance limit based on the uncensored data may or may not be actually higher than the value determined from the censored statistics.

A7.4 *Test Adjustment Factor*—Allowable shear stresses for structural glued laminated timber determined in accordance with 6.1.5 are based on block shear values of small-clear wood specimens. The shear reduction factor traditionally applied to test results of these small scale block shear specimens is 1/4.1, which is composed of the effects of load duration (10/16), stress concentration (4/9), and a factor of safety (8/9).

A7.4.1 Since the stress concentration factor of 4/9 is only applicable to small scale specimens, it is not included in the reduction factor to be applied to results of full-size beam tests. In addition, the factor of safety to be used in conjunction with full scale beam tests is revised to the same level that is applicable to the allowable flexural stress or 10/13. Combining this with the duration of load factor of 10/16 results in a net reduction factor of 1/2.1 that can then be applied to the shear test results of full-size glulam beams to establish design values.

A7.5 *Published Values*—The calculated shear stress may be reduced by 10 % to allow for occasional seasoning checking in accordance with industry recommended practice.

APPENDIX

X1. PROCEDURES FOR JUDGING ACCEPTANCE OF NEW MECHANICAL PROPERTY DATA

X1.1 *General*—A proposal for replacement of existing data shall include adequate statistical analyses and information to determine if the new data (1) substantiates retaining existing data; (2) augments existing data; or (3) replaces existing data.

X1.1.1 The new data set must have been sampled so as to be representative of the population in question. If the data set does not meet this criterion, additional data must be collected.

X1.2 *Parametric Comparison*—If, one of the competing data sets (current standard versus proposed alternative) belongs to one of the usual parametric families (for example, normal, log normal, Weibull, gamma) and the other does not (Note X1.1), then proceed to Table X1.1.

TABLE X1.1 Example Decision Sequence Based on Practical Application of Data

The following may be used when mechanical properties are determined to be different following a sequence such as X1.2-X1.4.

Step	
1	Apply the rounding rule of Practice D 245. If the new data remains different from the old, proceed.
2	Apply the rounded new data to a Practice D 3737-based beam analysis for one “classic” balanced and unbalanced lay up. If the lay-up of more than one depth between 4 and 20 laminations changes, the new data is considered different.
2a	If new knot data or other mechanical property data, or both, from this same lumber are also being examined for acceptance, this test shall be run with this new knot data and all new mechanical property, regardless of the outcome procedures for the other new data.

NOTE X1.1—As determined by statistical tests of goodness of fit. In general correlation-type and Cramer-Von Mises tests are to be preferred over χ^2 and Kolmogorov-Smirnov tests.

X1.3 *Nonparametric Tests*—If neither of the two data sets lies within one of the standard parametric families, perform the following nonparametric tests:

X1.3.1 The overall equality of the two distributions (for example, the two sample Kolmogorov-Smirnov tests),

X1.3.2 The equality of the “locations” of the two distributions (for example, the Wilcoxon rank sum test),

X1.3.3 The equality of the “scales” of the two distributions (for example, the Capon-Klotz test), and

X1.3.4 The equality of the fifth percentiles of the two distributions (for example, the modified Conover chi-squared test).

X1.3.5 If any of these tests is statistically significant, then proceed to Table X1.1. Otherwise, the two data sets can be treated as statistically equivalent.

X1.4 *Parametric Tests*—If a single parametric family contains both data sets (as judged by tests of goodness of fit), obtain maximum likelihood fits of the data sets to this parametric family. If these fits yield statistically different parameter estimates (for example, mean and variance estimates for normal fits; location, scale, and shape estimates for fits to a three-parameter Weibull), then proceed to Table X1.1. Otherwise, the two data sets can be treated as statistically equivalent.

X1.5 Visual Inspection—It is always wise to supplement formal statistical tests with visual inspection of data plots (Note). In general, these plots should not be used to overrule a finding that the two data sets are statistically different. They may be used, however, to overrule a finding that the two data sets are statistically equivalent. In this case, the investigator should then proceed to Table X1.1.

NOTE X1.2—For the purposes of this practice, three of the appropriate plots are (1) theoretical density superimposed on a data histogram, (2) theoretical cumulative distribution function superimposed on the empirical cumulative distribution function, and (3) probability plots (ordered data versus expected values of the ordered data).

X1.6 Appropriate Statistical Methods—The appropriate steps to take in analysis of data set are not easy to codify in advance. It may be appropriate to transform the data (for

example, by taking logs) or to delete outliers before the main analysis begins. It might happen that the tests of goodness-of-fit do not reject either the normal or the Weibull families (say) so that fits to both might be made. If the sample sizes are “small,” one might not want to rely on asymptotic maximum likelihood methods. Instead, one might want to rely on less powerful, but more robust nonparametric techniques. If it is desired that tests “emphasize regions of interest,” censored data statistical methods will need to be used in place of more standard methods. In short, the exact course of an appropriate statistical analysis cannot be entirely specified in advance. Considerable judgment must be exercised. For this reason it is recommended that a professional statistician be involved at all stages of the statistical analysis.

REFERENCES

- (1) Bendtsen, B. A. and Galligan, W. L., “Mean and Tolerance Limit Stresses and Stress Modeling for Compression Perpendicular to Grain in Hardwood and Softwood Species,” Research Paper FPL 337, U. S. Forest Product Laboratory, 1979.
- (2) Western Wood Products Association, “Western Lumber Grading Rules 81,” 1998.
- (3) West Coast Lumber Inspection Bureau, “Standard Grading Rules for West Coast Lumber,” No. 17, 1996.
- (4) Southern Pine Inspection Bureau, “Standard Grading Rules for Southern Pine Lumber”, 1994
- (5) National Lumber Grades Authority (NLGA) “Standard Grading Rules for Canadian Lumber”, 1997
- (6) Moody, R. C., “Improved Utilization of Lumber in Glued Laminated Beams,” Research Paper FPL 292, U.S. Forest Products Laboratory, 1977.
- (7) Freas, A. D., and Selbo, M. R., “Fabrication and Design of Glued Laminated Wood Structural Members,” Technical Bulletin No. 1069, U.S. Department of Agriculture, 1954 (Available only from American Institute of Timber Construction).
- (8) Wolfe, R. W., and Moody, R. C., “Bending Strength of Vertically Glued Laminated Beams with One to Five Plies,” Research Paper FPL 333, U.S. Forest Products Laboratory, 1979.
- (9) Forest Products Laboratory “Wood Handbook,” Agriculture Handbook No. 72, U.S. Department of Agriculture, 1987.
- (10) Marx, C. M., and Moody, R. C., “Strength and Stiffness of Shallow Glued-Laminated Beams with Different Qualities of Tension Laminations,” Research Paper FPL 381, U.S. Forest Products Laboratory, 1981.
- (11) Fox, S. P., “Bending Strength of a Proposed Douglas-fir 20f Glulam Stress Grade,” Western Forest Products Laboratory Information Report VP-X-175, Vancouver, B.C., Canada, 1978.
- (12) American Forest and Paper Association, National Design Specification for Wood Construction, 1997
- (13) Moody, R. C., “Design Criteria for Large Structural Glued Laminated Timber Beams Using Mixed Species of Visually Graded Lumber,” Research Paper FPL 236, U.S. Forest Products Laboratory, 1974.
- (14) Yeh, B., Williamson, T. G., and O’Halloran, M. R., “Shear Strength of Structural Glued Laminated Timber Based on Full-Size Flexure Tests,” Proceedings of the 1999 Pacific Timber Engineering Conference, Rotorua, New Zealand, 1999.
- (15) Lawless, J. F., “*Statistical Models and Methods for Lifetime Data*,” John Wiley and Sons, New York, NY, 1982.

ASTM International takes no position respecting the validity of any patent rights asserted in connection with any item mentioned in this standard. Users of this standard are expressly advised that determination of the validity of any such patent rights, and the risk of infringement of such rights, are entirely their own responsibility.

This standard is subject to revision at any time by the responsible technical committee and must be reviewed every five years and if not revised, either reapproved or withdrawn. Your comments are invited either for revision of this standard or for additional standards and should be addressed to ASTM International Headquarters. Your comments will receive careful consideration at a meeting of the responsible technical committee, which you may attend. If you feel that your comments have not received a fair hearing you should make your views known to the ASTM Committee on Standards, at the address shown below.

This standard is copyrighted by ASTM International, 100 Barr Harbor Drive, PO Box C700, West Conshohocken, PA 19428-2959, United States. Individual reprints (single or multiple copies) of this standard may be obtained by contacting ASTM at the above address or at 610-832-9585 (phone), 610-832-9555 (fax), or service@astm.org (e-mail); or through the ASTM website (www.astm.org).