



Standard Guide for Construction of Solid Fuel Burning Masonry Heaters¹

This standard is issued under the fixed designation E 1602; the number immediately following the designation indicates the year of original adoption or, in the case of revision, the year of last revision. A number in parentheses indicates the year of last reapproval. A superscript epsilon (ϵ) indicates an editorial change since the last revision or reapproval.

1. Scope

1.1 This guide covers the design and construction of solid fuel burning masonry heaters. It provides dimensions for site constructed masonry heater components and clearances that have been derived by experience and found to be consistent with the safe installation of those masonry heaters.

1.2 Values given in SI units are to be regarded as standard. Inch/pound units may be rounded (see IEEE/ASTM SI-10). All dimensions are nominal unless specifically stated otherwise. All clearances listed in this guide are actual dimensions.

1.3 This guide applies to the design and construction of masonry heaters built on-site with the components and materials specified herein. It does not apply to the construction/installation requirements for component systems that have been safety tested and listed. The requirements for listed masonry heater systems are specified in the manufacturer's installation instructions.

1.4 The design and construction of solid fuel burning masonry heaters shall comply with applicable building codes.

¹ This guide is under the jurisdiction of ASTM Committee E06 on Performance of Buildings and is the direct responsibility of Subcommittee E06.54 on Solid Fuel Burning Applications.

Current edition approved Jan. 10, 2004; Oct. 1, 2003. Published April 1, 2004. Originally published as E 1602 – 94. Last previous edition E 1602 – 94.

2. Referenced Documents

2.1 ASTM Standards:²

C 11 Terminology Relating to Gypsum and Related Building Materials and Systems

C 43 Terminology of Structural Clay Products

C 71 Terminology Relating to Refractories

C 270 Specification for Mortar for Unit Masonry

C 401 Classification of Alumina and Alumina-Silicate Castable Refractories

E 136 Test Method for Behavior of Materials in a Vertical Tube Furnace at 750°C

IEEE/ASTM SI-10 Standard for Use of the International System of Units (SI): The Modern Metric System

2.2 UL Standards:

UL 103 Chimneys, Factory Built Residential Type and Building Heating Appliances³

3. Terminology

3.1 Terms used in this guide are as defined in Terminology C 11, Definitions C 43, Terminology C 71, and Classification C 401.

3.2 Definitions of Terms Specific to This Standard:

3.2.1 *approved*—acceptable to the authority having jurisdiction.

3.2.2 *authority having jurisdiction*—the organization, office, individual, or agent thereof, who is responsible for approving construction, materials, equipment, installation, procedure, etc. and so forth. In most cases in which a building permit is required, the authority is typically the building official or his agent. Where a building permit is not required, the authority is typically the owner or his agent.

3.2.3 *bypass damper*—a valve or plate that provides a direct path to the chimney flue for the flue gases or portion thereof.

3.2.4 *capping slab*—a horizontal refractory barrier covering the top of the masonry heater.

3.2.5 *cleanout opening*—an access opening in a flue passageway of the masonry heater or chimney that is designed to allow access to the flue for purposes of inspecting for and removal of ash, soot, and other extraneous matter that may become trapped.

3.2.6 *damper*—an adjustable valve or plate for controlling draft or the flow of gases, including air.

3.2.7 *firebox (firechamber)*—that portion of the masonry heater that is designed for containing and burning the fuel charge.

3.2.8 *gas slot*—a small fixed opening that provides a bypass for unburned flue gases, and is a critical safety feature in certain masonry heater designs (namely those of the Grundofen type with vertical flue runs) (see Figs. 1 and Fig. 2, Fig. 32), and Fig. 6).

3.2.9 *hearth extension*—the noncombustible surfacing applied to the floor area extending in front of and beyond each side of the fuel loading door of the masonry heater; also applies to the floor beneath a masonry heater or beneath an elevated overhanging masonry heater hearth.

3.2.10 *masonry heater base*—that portion of the support for the masonry heater, between the masonry heater and the foundation, that is below the firebox or the heat exchange areas.

3.2.11 *heat-exchange flue channel*—a chamber or passageway between the firebox and the chimney flue in which heat resulting directly from combustion of fuel is transferred to the surrounding masonry.

3.2.12 *kachel*—a European term used to describe a masonry heater tile; a refractory ceramic tile intended for the outer wall of a masonry heater that is designed specifically to store and transfer heat.

3.2.13 *listed*—equipment or materials included in a list published by an organization concerned with product evaluation acceptable to the authority having jurisdiction to conduct periodic inspection of production of listed equipment or materials and whole listing states either that the equipment or materials meet appropriate standards or have been tested and found suitable for use in a specified manner.

3.2.14 *masonry heater*—a vented heating system of predominantly masonry construction having a mass of at least 800 kg (1760 lbs), excluding the chimney and masonry heater base. In particular, a masonry heater is designed specifically to capture and store a substantial portion of the heat energy from a solid fuel fire in the mass of the masonry heater through internal heat exchange flue channels, enable a charge of solid fuel mixed with an adequate amount of air to burn rapidly and more completely at high temperatures in order to reduce emission of unburned hydrocarbons, and be constructed of sufficient mass and surface area such that under normal operating conditions, the external surface temperature of the masonry heater (except in the region immediately surrounding the fuel loading door(s)), does not exceed 110°C (230°F).

3.2.15 *mortar, masonry*—a mixture of cementitious materials (consisting of Portland or blended cement and hydrated lime, masonry cement, masonry cement and Portland cement, or masonry cement and blended cement), fine aggregate, and sufficient water to produce a workable consistency (see Specification C 270).

3.2.16 *mortar, fire clay*—mortar consisting of fine aggregate and fire clay as a binding agent.

² For referenced ASTM standards, visit the ASTM website, www.astm.org, or contact ASTM Customer Service at service@astm.org. For Annual Book of ASTM Standards; Vol 04.01; volume information, refer to the standard's Document Summary page on the ASTM website. *Annual Book of ASTM Standards, Vol 04.05.*

³ Available from Underwriter's Laboratories, 333 Pfingsten Road, Northbrook, IL 60062.

FIG. 1 Vertical Channel
Masonry Heater
(Russian)

1. Ashbox
2. Ash Drop
3. Capping Slab
4. Chimney
5. Clean-Out
6. Combustion Air
7. Downdraft Channel
8. Exhaust Gas
9. Expansion Joint
10. Exterior Wall
11. Firebox
12. Fuel-Loading Door
13. Gas Slot
14. Hearth Extension
15. Heater Base
16. Insulation
17. Shut-Off Damper
18. Updraft Channel

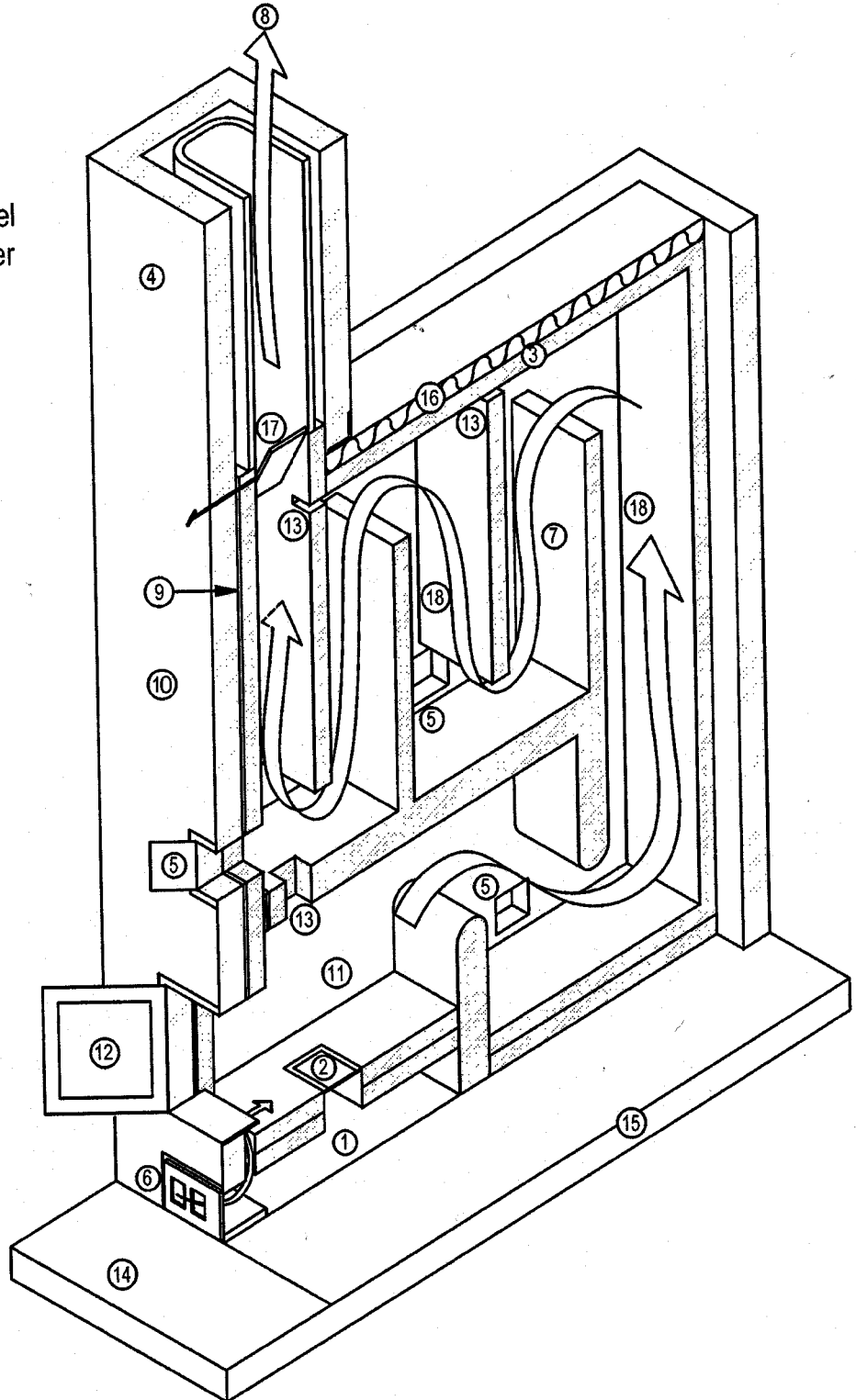

FIG. 2 Horizontal Channel Masonry Heater (Russian)

1. Ashbox
2. Ash Drop
3. Capping Slab
4. Chimney
5. Clean-Out
6. Combustion Air
7. Exhaust Gas
8. Expansion Joint
9. Exterior Wall
10. Firebox
11. Fuel-Loading Door
12. Gas Slot
13. Hearth Extension
14. Heater Base
15. Horizontal Channel
16. Insulation
17. Shut-Off Damper

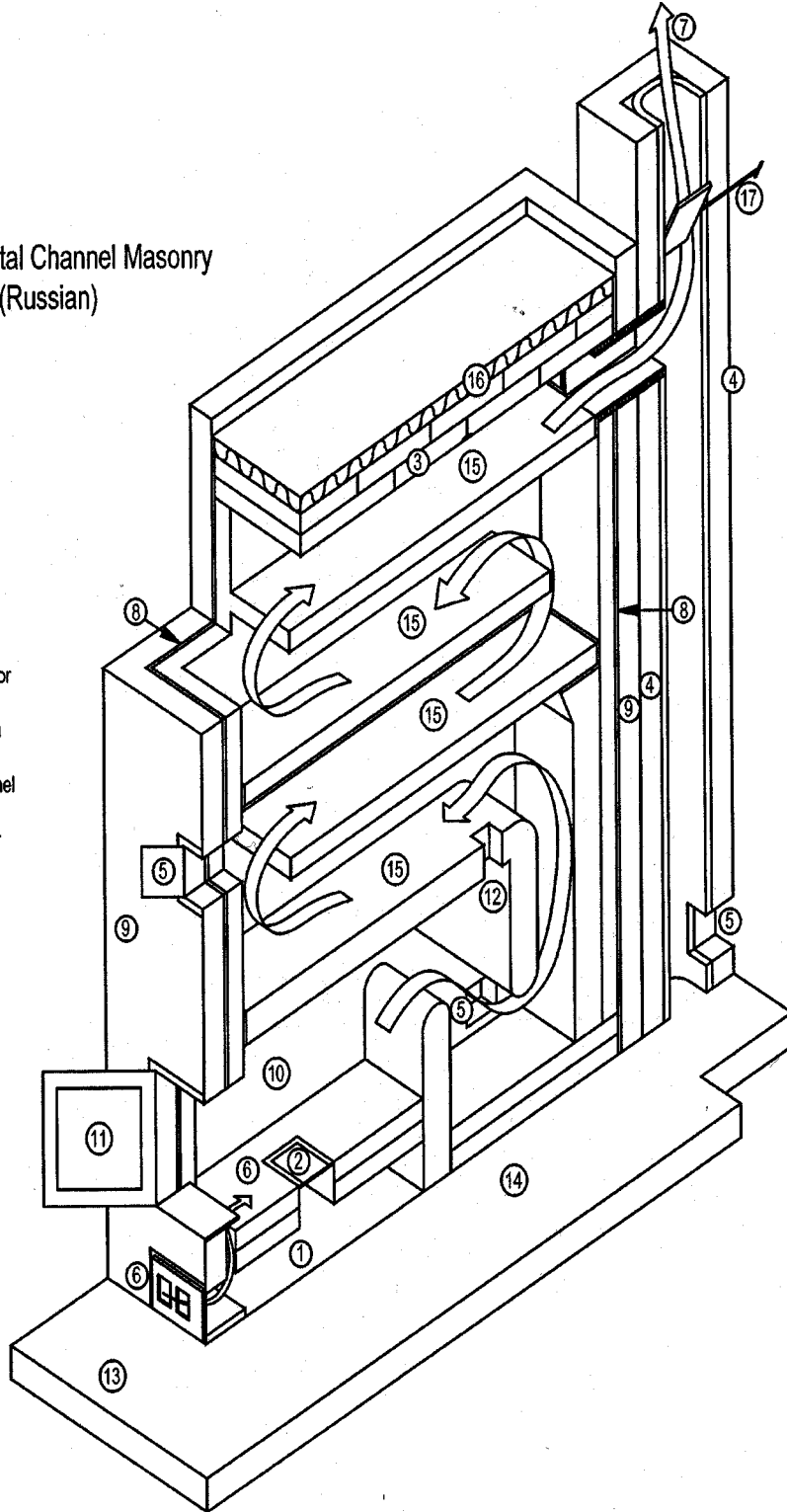
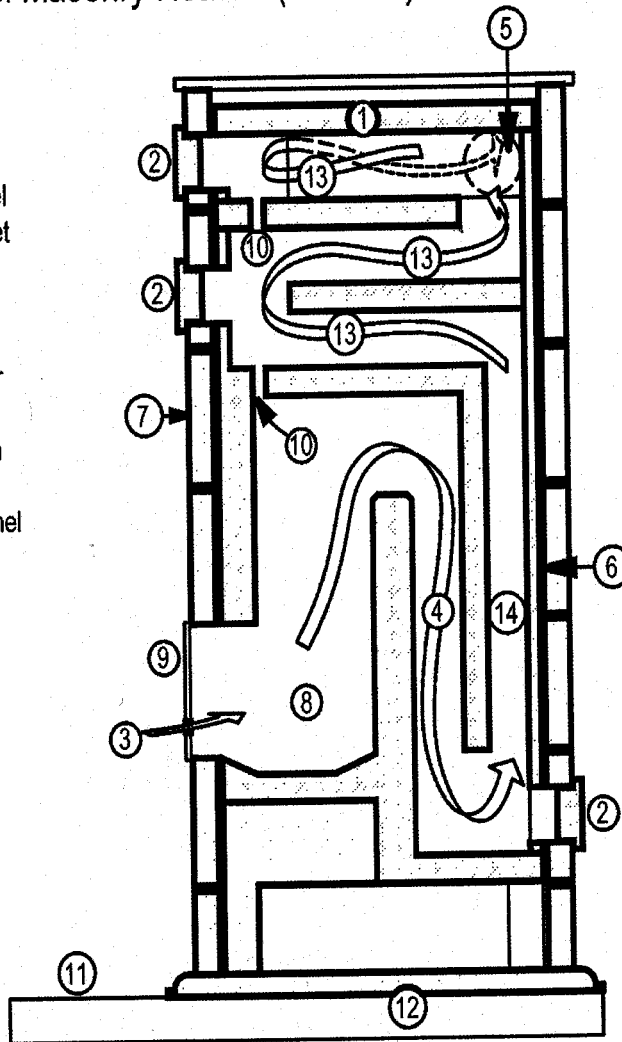

FIG. 3 Combination Vertical and Horizontal Channel Masonry Heater (German)

1. Capping Slab
2. Clean-Out
3. Combustion Air
4. Downdraft Channel
5. Exhaust Gas Outlet
6. Expansion Joint
7. Exterior Wall
8. Firebox
9. Fuel-Loading Door
10. Gas Slot
11. Hearth Extension
12. Heater Base
13. Horizontal Channel
14. Updraft Channel



3.2.17 *mortar, soapstone refractory*—a mixture of powdered soapstone and sodium silicate.

3.2.18 *noncombustible material*—a material that, in the form in which it is used and under the conditions anticipated, does not ignite, burn, support combustion, or release flammable vapors when subjected to fire or heat. Materials reported as passing the requirements of Test Method E 136 are, for the purpose of this guide, considered noncombustible.

3.2.19 *soapstone*—a variety of natural stone (hydrated silica of magnesium) that is suitable for high-temperature applications in masonry heaters.

3.2.20 *wing wall*—a noncombustible lateral projection from the exterior wall of a masonry heater for use in bridging the space between a masonry heater and a combustible partition wall.

4. Significance and Use

4.1 This guide can be used by code officials, architects, and other interested parties to evaluate the design and construction of masonry heaters. It is not restricted to a specific method of construction, nor does it provide all specific details of construction of a masonry heater. This guide does provide the principles to be followed for the safe construction of masonry heaters.

4.2 This guide is not intended as a complete set of directions for construction of masonry heaters.

4.3 Construction of masonry heaters is complex, and in order to ensure their safety and performance, construction shall be done

FIG. 5 Contraflow Masonry Heater
(Finnish)

1. Ashbox
2. Ash Drop
3. Bypass Damper
4. Capping Slab
5. Chimney
6. Clean-Out
7. Combustion Air
8. Downdraft Channel
9. Exhaust Gas
10. Expansion Joint
11. Exterior Wall
12. Firebox
13. Fuel-Loading Door
14. Hearth Extension
15. Heater Base
16. Insulation
17. Shut-Off Damper

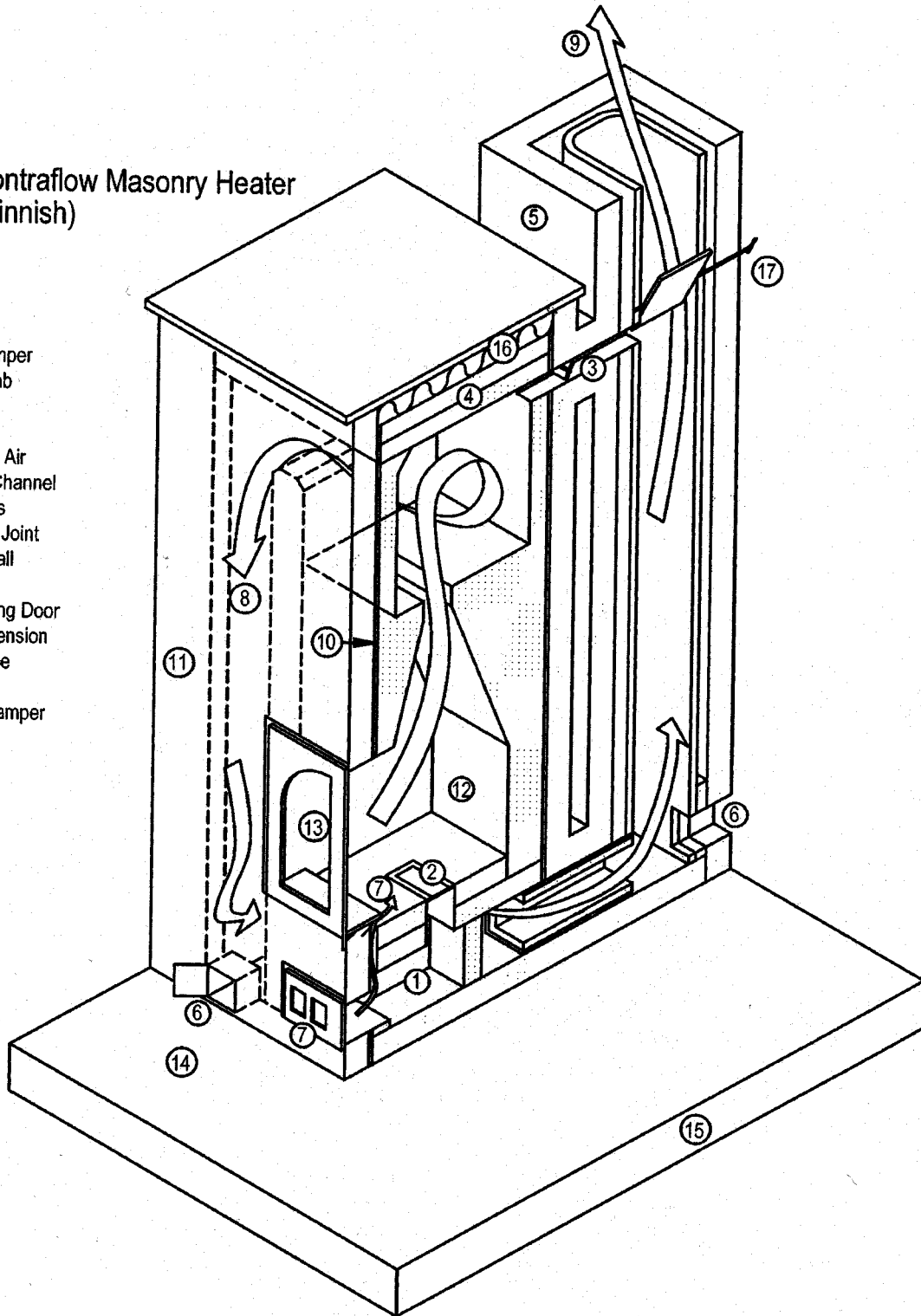

by or under the supervision of a skilled and experienced masonry heater builder.⁴

Annual Book

⁴ The Masonry Heater Association of ASTM Standards, Vol 15.01, North America, 1252 Stock Farm Road, Randolph, VT 05060, web site: <http://www.mha-net.org>, is one organization that represents a body of knowledge on masonry heater construction and qualified builders.

FIG. 6 Five Channel Masonry Heater
(Swedish)

1. Capping Slab
2. Clean-Out
3. Combustion Air
4. Downdraft Channel
5. Exhaust Gas Outlet
6. Expansion Joint
7. Exterior Wall
8. Firebox
9. Fuel-Loading Door
10. Gas Slot or Bypass Damper
11. Hearth Extension
12. Heater Base
13. Insulation
14. Updraft Channel

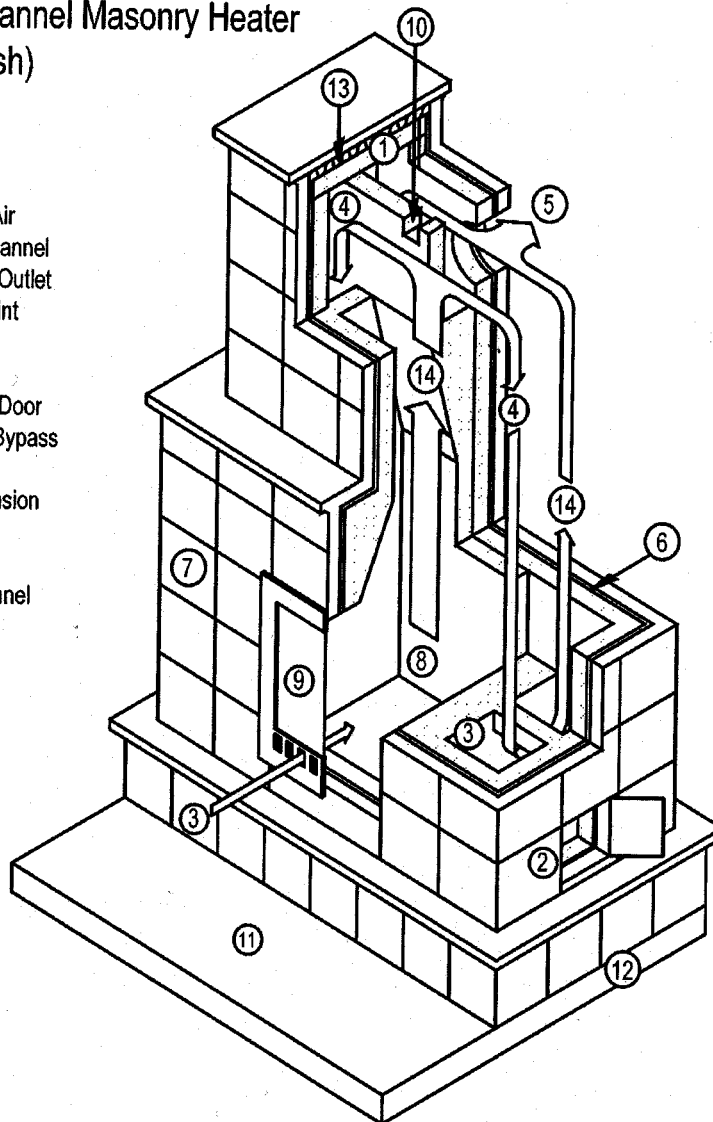

5. Requirements

5.1 *Foundation*—Masonry heater foundations and foundation walls shall meet local building codes for standard masonry fireplaces and shall be designed with consideration given to the mass and size of the masonry heater.

5.2 *Clearance from Combustibles*—Clearances shall be in conformance with this section, as illustrated in Fig.-3- 4.

5.2.1 *Clearance from Foundation*—All combustible structural framing members shall have a clearance of not less than 50 mm (2 in.) from the masonry heater foundation.

5.2.2 *Clearance from Fuel-Loading Door*— Maintain a minimum clearance of 1200 mm (48 in.) from combustible materials to fuel-loading doors, unless an engineered protection system as specified in 5.2.2.1 is provided, except for clearance directly in front of fuel-loading doors. A minimum clearance of 1200 mm (48 in.) shall be maintained in front of fuel-loading doors. This dimension shall not be reduced for any reason.

5.2.2.1 Clearance from fuel-loading doors to combustible materials may be reduced, other than in front of fuel-loading doors, if the combustible material is protected by an engineered protection system acceptable to the authority having jurisdiction. Engineered systems installed for the protection of combustible material shall limit the temperature of the combustible material to 50°C (90°F) above ambient temperature. Systems shall be designed upon applicable heat transfer principles, taking into account the geometry of the system, the heat loss characteristics of the structure behind the combustible material, and possible abnormal operating conditions of the masonry heater.

The Masonry Products Caucus of the Hearth Products Association, 1601 N. Kent Street, Suite 1001, Arlington, VA 22209, web site: <http://www.hearthassoc.org>, is another organization that represents both manufacturers and qualified builders of masonry heaters.

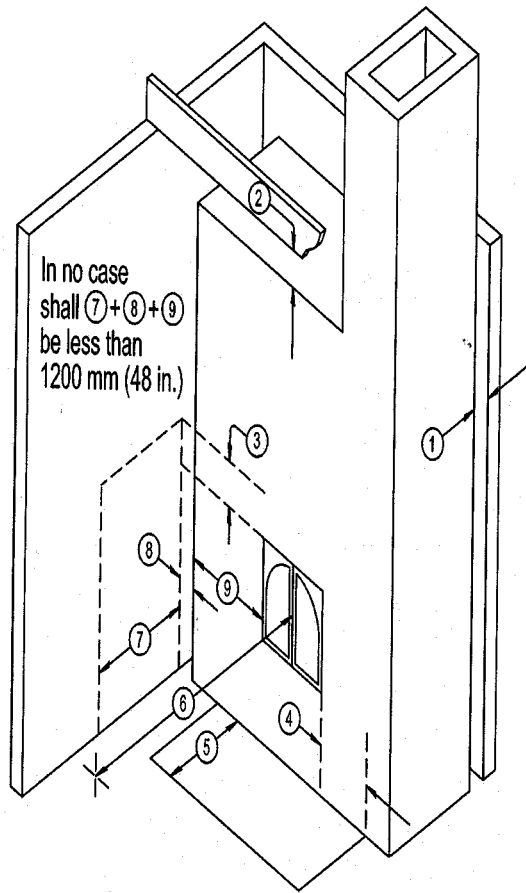

FIG. 4 Clearances to Combustibles

- 1- 100 mm (4 in.) to combustibles from masonry heater
- 2- 200 mm (8 in.) to ceiling
- 3- 200 mm (8 in.) minimum extent of side wall heat shield above firebox door
- 4- 300 mm (12 in.) hearth extension (sides)
- 5- 500 mm (20 in.) hearth extension (front)
- 6- 1200 mm (48 in.) in front of fuel-loading doors to combustibles
- 7- extent of mandatory heat shield in front of masonry heater; required only when clearance to combustibles from fuel-loading door (8+9) is less than 1200 mm (48 in.)
- 8- 100 mm (4 in.) minimum clearance from side wall of masonry heater to heat shield (if used) or combustibles
- 9- distance from fuel-loading doors to side wall of masonry heater
- 7+8+9- The sum of these must be greater than or equal to 1200 mm (48 in.)

Notes: Clearances from combustibles walls or framing may be reduced with an engineered protection system, other than in front of fuel-loading doors.

5.2.2.1.1 When an engineered protection system is used to reduce the perpendicular clearance from fuel-loading doors, it must extend a minimum of 200 mm (8 in.) above the fuel-loading doors or firebox opening. In addition, the sum of the dimensions from the fuel-loading doors, the distance from the heater to combustibles material, and the length of the protection system in front of the heater face shall be no less than 1200 mm (48 in.).

5.2.3 Clearance from Rear, Side, and Front Walls—Clearance from a masonry heater to combustibles structural framing and other combustibles materials shall be not less than 100 mm (4 in.), unless an engineered protection system is provided, or a

protection system accepted by the authority having jurisdiction is provided.

5.2.3.1 Clearance from a masonry heater to combustible materials may be reduced by the use of materials or products listed for protection purposes. Materials and products listed for the purpose of reducing clearance to combustibles shall be installed in accordance with the conditions of the listing and the manufacturer's instructions and shall meet the criteria of Section 5.2.2.1.

5.2.4 *Clearance from the Ceiling*—The clearance from the masonry heater capping slab to the ceiling shall be a minimum of 200 mm (8 in.).

5.2.4.1 *Extensions of Exterior Wythes to Ceiling*—When exterior masonry wythes of the masonry heater are carried to the ceiling, insulate and vent the top of the masonry heater above the heat exchange channels to reduce possible static heat buildup.

5.2.5 *Wing Walls*—Wing walls may be added to a masonry heater and used as room partitions. Wing walls located at the corners of a masonry heater for the purpose of forming a room divider shall be a minimum of 100 mm (4 in.) in length and a maximum of 100 mm (4 in.) in thickness and be constructed with noncombustible materials. Wing walls located more than 200 mm (8 in.) from a corner of the masonry heater shall be a minimum of 200 mm (8 in.) in length and a maximum of 100 mm (4 in.) in thickness and be constructed with noncombustible materials.

5.3 *Firebox Floor*—The firebox floor shall be a minimum thickness of 100 mm (4 in.) of noncombustible material and at least the top 50 mm (2 in.) shall be refractory material. The firebox floor or a portion thereof may also contain a cast iron grating.

5.4 *Hearth Extension:*

5.4.1 Masonry heaters shall have hearth extensions of brick, concrete, stone, tile, or other approved noncombustible material properly supported. Remove wooden forms used during the construction of hearth and hearth extension once construction is completed.

5.4.2 *Closed Door Fireboxes*—With a masonry heater designed to be fired with a closed door of glass or metal, the hearth extension shall be at least 500 mm (20 in.) in front of the facing materials and at least 300 mm (12 in.) beyond each side of the masonry heater opening. When a raised hearth of at least 200 mm (8 in.) in height is used and the hearth extension is located at the base of the door, the hearth extension can be reduced to 400 mm (16 in.) in front of the facing materials.

5.4.3 *Open Fireboxes:*

5.4.3.1 Where the firebox opening is less than 0.6 m² (6 ft²), the hearth extension shall extend at least 400 mm (16 in.) in front of the facing materials and at least 200 mm (8 in.) beyond each side of the firebox opening.

5.4.3.2 Where the firebox opening is 0.6 m² (6 ft²) or larger, the hearth extension shall extend at least 500 mm (20 in.) in front of the facing materials and at least 300 mm (12 in.) beyond each side of the firebox opening.

~~5.4.3 *Closed Door Fireboxes*—With a masonry heater designed to be fired with a closed door of glass or metal, the hearth extension shall be at least 500 mm (20 in.). When a raised hearth of at least 200 mm (8 in.) in height is used and the hearth extension is located at the base of the door, the hearth extension shall be at least 400 mm (16 in.).~~

5.4.4 Where a firebox opening overhangs a floor, the hearth extension shall also cover the area beneath the overhang and extend beyond the firebox opening as specified in 5.4.3.2.

5.5 *Cleanout Openings:*

5.5.1 Chimney flues shall have a cleanout access at their base.

5.5.2 *Heat Exchange Channels*—If the design limits natural access, install cleanout openings or a means for cleaning all chimney flues and heat exchange areas. If an ash dump or grate is provided in the firebox, provide a tight-fitting cover of noncombustible material, 3 mm (1/8 in.) minimum thickness, at the base of the ash pit. Cleanout doors for the foundation shall have a minimum size of 200 by 200 mm (8 by 8 in.). Situate the opening to facilitate inspection, cleaning, and maintenance of the masonry heater.

5.6 *Outside Combustion Air*—When required by the local building code, provide a duct with a minimum cross-sectional area of 7700 mm² (12 in.²) or equivalent. When outside combustion air is required by the authority having jurisdiction the duct shall have a damper that can be fully closed when not in use. Materials shall be non-combustible and methods of construction shall comply with the requirements of the authority having jurisdiction.

5.6.1 In applications in which outside air is introduced directly into the firebox, the air duct must enter the building at a level below the firebox.

5.6.2 Design and position the air inlet to prevent live coals from entering the air duct. To prevent rodents from entering the air duct, cover the outside entry opening of the duct with a 6 mm (1/4 in.) corrosion resistant wire mesh.

5.6.3 *Ash Pit Located in Foundation*— When outside air is introduced into the firebox via the ash pit, introduce the air duct through the upper region of the ash pit wall.

5.6.4 When outside air is introduced into the firebox, construct the air duct from noncombustible materials.

5.7 *Heat exchange channels:*

5.7.1 Heat exchange channels shall be built with firebrick, soapstone, or other refractory materials laid in refractory mortar, fire clay mortar, or soapstone refractory mortar. Masonry units shall be laid with full mortar joints.

5.7.2 *Capping Slab*—A capping slab shall be of at least 57 mm (2 1/4 in.) in actual thickness above the uppermost heat exchange channels.

5.7.3 *Gas Slot*—When required, a gas slot shall have a cross-sectional area of at least 1/30 of the firebox floor area and a height of 30 mm (1 1/4 in.). Refer to Fig. 1, Fig. 2, Fig. 3, and Fig. 6 for typical locations.

5.8 *Shut-off Damper(s)*—One or more shut-off dampers may be installed near the juncture of the masonry heater and chimney or in the chimney. Each damper shall have external controls and be constructed of cast iron or steel of at least 12 gauge, 2.5 mm (0.10 in.) in thickness. To reduce the possibility of toxic gases escaping into the room, the cross-sectional area of the damper's opening shall be not less than 5 % of the interior cross sectional area of the flue.

5.9 *Chimney*—Vent masonry heaters with a low-heat type masonry chimney approved by the authority having jurisdiction or with a factory-built residential type chimney that meets the requirements of UL 103 HT.

5.9.1 The chimney shall not be supported by the interior walls of the masonry heater unless specifically designed to do so. The chimney can be built integrally with an exterior wythe of the masonry heater, provided the exterior wythe is constructed of solid masonry and has a minimum thickness of 100 mm (4 in.).

5.9.2 Flue sizes shall be in accordance with the design specification of the builder or the designer of the masonry heater.

5.10 *Chimney Connector*—The chimney connector shall be accessible for inspection and cleaning. Chimney connectors shall be airtight and fitted with airtight joints. Where differential movement can take place between a masonry heater and chimney, make provision for this movement in such a way as to maintain the integrity of the connector joints. Materials and methods of construction shall comply with the requirements of the authority having jurisdiction.

6. Typical Masonry Heater Types

6.1 There are several different masonry heater types. Fig. 1, Fig. 2, Fig. ~~4~~, 3, Fig. 5, and Fig. ~~5~~ 6 show the names and schematic sections of typical masonry heater designs.

7. Keywords

7.1 brick; Contraflow; firebrick; fire clay mortar; Grundofen; Kachelofen; Kakelugn; masonry heater; mortar; refractory mortar; Russian; soapstone refractory mortar

ASTM International takes no position respecting the validity of any patent rights asserted in connection with any item mentioned in this standard. Users of this standard are expressly advised that determination of the validity of any such patent rights, and the risk of infringement of such rights, are entirely their own responsibility.

This standard is subject to revision at any time by the responsible technical committee and must be reviewed every five years and if not revised, either reapproved or withdrawn. Your comments are invited either for revision of this standard or for additional standards and should be addressed to ASTM International Headquarters. Your comments will receive careful consideration at a meeting of the responsible technical committee, which you may attend. If you feel that your comments have not received a fair hearing you should make your views known to the ASTM Committee on Standards, at the address shown below.

This standard is copyrighted by ASTM International, 100 Barr Harbor Drive, PO Box C700, West Conshohocken, PA 19428-2959, United States. Individual reprints (single or multiple copies) of this standard may be obtained by contacting ASTM at the above address or at 610-832-9585 (phone), 610-832-9555 (fax), or service@astm.org (e-mail); or through the ASTM website (www.astm.org).