



# Standard Specification for Core-Splice Adhesive for Honeycomb Sandwich Structural Panels<sup>1</sup>

This standard is issued under the fixed designation E 990; the number immediately following the designation indicates the year of original adoption or, in the case of revision, the year of last revision. A number in parentheses indicates the year of last reapproval. A superscript epsilon ( $\epsilon$ ) indicates an editorial change since the last revision or reapproval.

## 1. Scope

1.1 This specification covers core-splice adhesive for use with nonmetallic honeycomb cores in the fabrication of honeycomb sandwich panels used in relocatable structures. The adhesive shall be used for new production or depot repair. The adhesive shall be suitable for forming bonds that can withstand long combinations of stress, temperature, and relative humidity expected to be encountered in service. The adhesive shall be used for bonding core segments and for bonding core segments to edge members and to integral members in a honeycomb sandwich panel. The adhesive shall not allow the transfer of water from one part of the panel to another either through or along the line of the adhesive.

1.2 The values stated in SI units are to be regarded as the standard. The values given in parentheses are for information only.

1.3 The following precautionary caveat pertains only to the test method portion, Section 5, of this specification: *This standard does not purport to address all of the safety concerns, if any, associated with its use. It is the responsibility of the user of this standard to establish appropriate safety and health practices and determine the applicability of regulatory limitations prior to use.*

## 2. Referenced Documents

### 2.1 ASTM Standards:<sup>2</sup>

- B 209 Specification for Aluminum and Aluminum-Alloy Sheet and Plate
- C 393 Test Method for Flexural Properties of Sandwich Constructions
- D 792 Test Methods for Density and Specific Gravity (Relative Density) of Plastics by Displacement
- E 864 Practice for Surface Preparation of Aluminum Alloys to be Adhesively Bonded in Honeycomb Shelter Panels

<sup>1</sup> This specification is under the jurisdiction of ASTM Committee E06 on Performance of Buildings and is the direct responsibility of Subcommittee E06.53 on Materials and Processes for Durable Rigid Wall Relocatable Structures.

Current edition approved April 1, 2004. Published April 2004. Originally approved in 1984. Last previous edition approved in 1998 as E 990 – 98.

<sup>2</sup> For referenced ASTM standards, visit the ASTM website, [www.astm.org](http://www.astm.org), or contact ASTM Customer Service at [service@astm.org](mailto:service@astm.org). For *Annual Book of ASTM Standards* volume information, refer to the standard's Document Summary page on the ASTM website.

E 865 Specification for Structural Film Adhesives for Honeycomb Sandwich Panels

E 874 Practice for Adhesive Bonding of Aluminum Facings to Nonmetallic Honeycomb Core for Shelter Panels

E 1091 Specification for Nonmetallic Honeycomb Core for Use in Shelter Panels

### 2.2 Federal Standards:

QQ-A-250/4 Aluminum Alloy 2024, Plate and Sheet<sup>3</sup>

QQ-A-250/8d Aluminum Alloy 5052H34, Plate and Sheet<sup>3</sup>

QQ-A-250/11d Aluminum Alloy 6061T6, Plate and Sheet<sup>3</sup>

### 2.3 Military Standards:

MIL-S-8802 Sealing Compound, Temperature-Resistant, Integral Fuel Tanks, and Fuel Cell Cavities, High-Adhesion<sup>3</sup>

## 3. Materials and Manufacture

3.1 The adhesive shall be free of foreign materials, be noncorrosive to the metal parts, and have the structural integrity equal to or better than that of an unspliced panel section as specified in Table 1, Flexural Shear.

## 4. Requirements

4.1 *Material*—The adhesive shall be thermosetting and when tested in accordance with Section 5, shall meet the requirements of Table 1. The adhesive shall not have a deleterious effect on the panel nor on its component parts over the range of temperature at which the adhesive will be used. This adhesive shall be compatible and capable of co-curing with the structural film adhesive (Specification E 865) used to fabricate the panel.

4.2 *Form*—The adhesive shall be of film form either 1.27 mm (0.051 in.) or 2.54 mm (0.100 in.) thick and shall be capable of expanding to at least 1.75 times its original thickness.

### 4.3 Working Characteristics:

4.3.1 *Application*—The adhesive shall be suitable for application to core material, edge members, and integral parts in accordance with the manufacturer's instructions at temperatures from 18 to 30°C (65 to 85°F) and at relative humidities of up to 50 %.

<sup>3</sup> Available from Standardization Documents Order Desk, DODSSP, Bldg. 4, Section D, 700 Robbins Ave., Philadelphia, PA 19111-5098

**TABLE 1 Physical Properties Qualification Requirements**

Table	Reference Paragraph	Requirements
Water migration	5.1	Not more than the volume of the cavity (in cell)
Volatility	5.2	1 % maximum
Expansion	5.3	1.75 minimum ratio
Sag for 1.27 mm (0.05 in.) uncured thickness	5.4	3.8 mm (0.15 in.) maximum
Sag for 2.54 mm (0.1 in.) uncured thickness	5.4	12.7 mm (0.500 in.) maximum
Density (cured)	5.5	0.8 g per cm <sup>3</sup> (50 lb/ft <sup>3</sup> ) maximum
Flexural shear (assembly compatibility)	5.6	Same as honeycomb core, minimum 1.24 MPa (180 psi) L-direction
Tube shear (core splice integrity)	5.7	Minimum average 4.13 MPa (600 psi) Minimum individual 3.1 MPa (450 psi)

4.3.2 *Curing*—The time, temperature, and pressure used to cure the adhesive shall be as specified herein.

4.3.2.1 *Curing Time and Temperature*—The adhesive shall meet the requirements of this specification when cured in accordance with manufacturer’s recommendation so long as the time and bondline temperature do not exceed 1 h or 145°C (293°F).

4.3.2.2 *Curing Pressure*—The pressure required for curing the adhesive shall be contact.

4.4 *Storage Life*—The adhesive shall have a minimum storage life of 3 months from the date of receipt at the fabricator facility when stored at –17.8°C (0°F) or below. Under conditions in accordance with 4.3.1, the adhesive shall have a cumulative out-life of at least 5 days at 24 ± 3°C (75 ± 5°F).

4.5 *Properties*—The properties of the test specimens prepared and tested as described herein shall conform to the requirements of Table 1.

**5. Test Methods**

**5.1 Water Migration Test:**

5.1.1 The core Splice Adhesive Mold is illustrated in Fig. 1 (Note 1). Apply a mold release agent to both the interior of the female portion and the exterior of the male portion of the mold. Install a layer of adhesive (Note 2) on the entire length of the 19.05 mm diameter part of the male portion of the mold so that the layer of adhesive overlaps along a vertical seam. Close the mold by lowering the female portion over the male portion until it seats against the base of the male portion. A press may be used to help close the mold. Remove the mold from the press and place in an oven. Cure in the oven at 121 ± 5.6°C (250 ± 10°F) for 1 h minimum. Remove cured adhesive from the mold.

NOTE 1—The mold may be made of aluminum, acrylic plastic, or other suitable material. The outer shell may be fabricated as a split mold.

NOTE 2—Depending on the expansion ratio and the unexpanded thickness of the material being tested, it may be necessary to install more than one layer of adhesive. The size of the adhesive shall be calculated as follows: Length × width × thickness = 1.65 cm<sup>3</sup> (0.65 in.<sup>3</sup>).

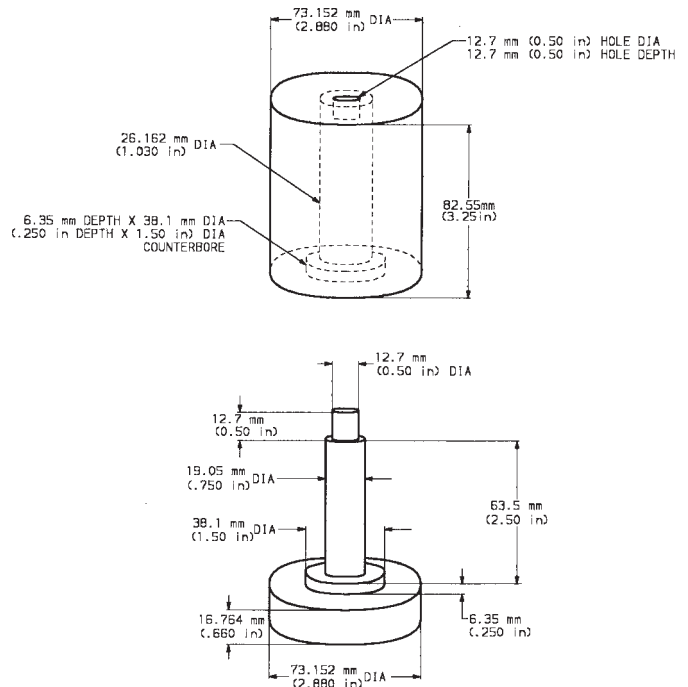

**FIG. 1 Core Splice Adhesive Mold**

5.1.2 Prepare the sample (approximately 38 mm (1½ in.) long) by cutting the cylinder of cured adhesive and visually check to ensure that there are no cracks, pin holes, and so forth.

5.1.3 Cover a piece of aluminum (approx. 50 × 50 × 6 mm) (2 × 2 × ¼ in.) with MIL-S 8802, Class B-2 Sealant, or equivalent, to a depth of 3 to 6 mm (⅛ to ¼ in.). Use a “dam,” such as vacuum-bagging putty or an aluminum foil tray, around the edge of the aluminum to prevent the sealant from running off (see Fig. 2).

5.1.4 Place the prepared sample of adhesive (5.1.2) on the sealant and seat it gently into the sealer. Allow the sealant to cure at room temperature overnight.

5.1.5 Install a glass tube approximately 38 mm (1½ in.) long approximately 19 mm (¾ in.) down into the hole in the top of the specimen, and seal between the glass tube and the test specimen with MIL-S-8802, Class B-2 sealant, or equivalent. Allow the sealant to cure at room temperature overnight.

5.1.6 Fill the cell in the sample through the glass tube with distilled water using a hypodermic needle. Inject the water at the bottom to ensure that the cell is full and that no air is entrapped. Measure the volume required to fill the cell.

5.1.7 Connect a buret filled with distilled water to the glass tube using a clear polyethylene tubing (see Fig. 3). Adjust the buret to a height of 914.4 mm (36 in.) above the top of the test specimen and ensure that there is no entrapped air.

5.1.8 The water migration through the adhesive tube specimen shall not exceed the number of millilitres required to fill the cavity (approximately 12 mL (0.4 oz)) when subjected to a 915 mm (36-in.) head for 24 h.

5.2 *Volatile Test*—Volatility of the film adhesive shall be tested in accordance with the procedure in 5.2.1-5.2.9.

5.2.1 Cut the adhesive into three one-ply test specimens. Each specimen is to be a 51-mm (2-in.) diameter disk or 51 by 51-mm (2 by 2-in.) square.

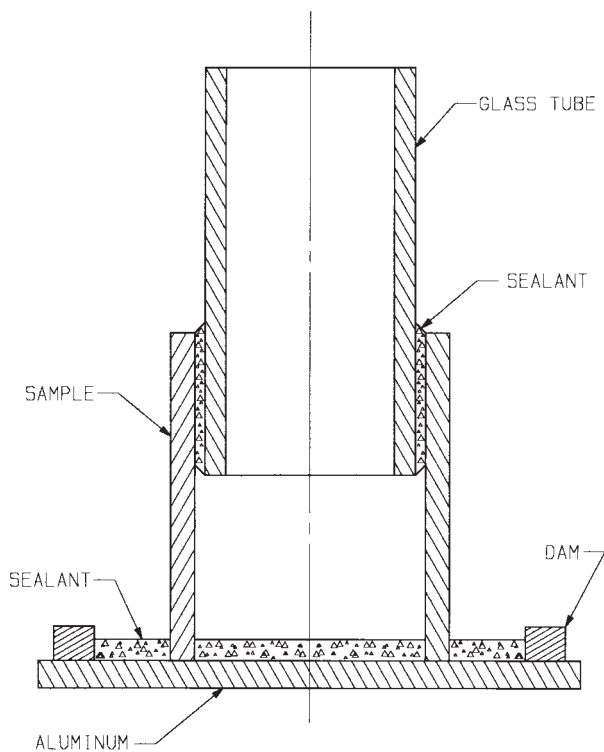

FIG. 2 Water Migration Test Specimen Assembly

5.2.2 Weigh the containers that will be used in the cure of the test specimens cut in 5.2.1. Each container shall be an aluminum moisture dish, of sufficient size to allow the specimen to lie in the bottom without the edges of the specimen touching the side of the container. ( $W_1$  = weight of container.)

5.2.3 Place each specimen in a container, then place the containers in a desiccator that contains a desiccant such as dryerite for 2 h  $\pm$  10 min at room temperature, 24  $\pm$  3°C (75  $\pm$  5°F).

5.2.4 Remove the container and specimen from the desiccator and weigh. This weight shall be designated as  $W_2$ . ( $W_2$  = weight of container plus weight of uncured adhesive.)

5.2.5 Cure the specimens in a forced-air circulating oven. The time and temperature shall be in accordance with 4.3.2.1. When a cure temperature range is specified, the volatility test shall be conducted at the maximum curing temperature.

5.2.6 Remove the containers and cured specimens from the oven while at cure temperature, and place in a desiccator and cool to room temperature, 24  $\pm$  2.8°C (75  $\pm$  5°F).

5.2.7 Remove the cooled containers and specimens from the desiccator and reweigh. This weight shall be designated as  $W_3$ . ( $W_3$  = weight of cured adhesive and container.)

5.2.8 The percent weight loss shall be calculated as follows:

$$V = \frac{W_2 - W_3}{W_2 - W_1} \times 100 \quad (1)$$

where:

- $V$  = weight loss (volatility), %,
- $W_1$  = weight of container, g (oz),
- $W_2$  = weight of container plus weight of uncured adhesive, g (oz), and
- $W_3$  = weight of cured adhesive and container, g (oz).

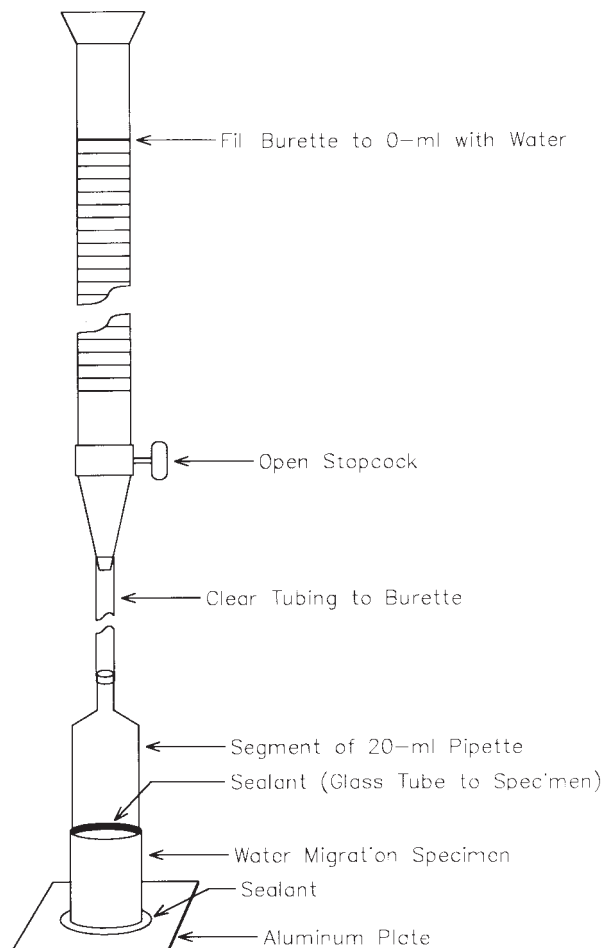

FIG. 3 Water Migration Test

5.2.9 The percent of weight loss of three specimens shall be averaged and reported as volatility.

5.3 *Expansion Test*—Cut three specimens of the core splice adhesive (approx. 102  $\times$  102 mm) (4  $\times$  4 in.) with the liners intact. Record the average thickness (at least three readings per specimen) of the core splice adhesive and protective liners to nearest 0.025 mm (0.001 in.). Remove one liner and place the adhesive, exposed face down, on a piece of heat resistant release material, being careful to eliminate entrapped air between the core splice adhesive and the release material. Remove the second original liner from the adhesive and cure the adhesive without pressure in accordance with 4.3.2.1. Record the average thickness (at least three readings) of the cured core splice film to the nearest 0.025 mm (0.001 in.). Measure the combined thickness of the two liners. Calculate the expansion ratio as follows:

$$E = A/B \times 100 \quad (2)$$

where:

- $E$  = expansion ratio,
- $A$  = thickness of the cured film (no liner), mm (in.), and
- $B$  = thickness of uncured film (with liners) minus the combined thickness of liners, mm (in.).

5.4 *Sag Test*—Cut three specimens of the core splice adhesive (approx. 102 by 102 mm) (4 by 4 in.). Remove both pieces

of liner material and place one edge of each specimen against a 153-mm (6-in.) long scribed line on a clean aluminum plate using hand pressure to ensure contact and to remove entrapped air bubbles. Place the specimen vertically in an air circulating oven so that the scribe line is at the bottom of the specimen. Cure in accordance with 4.3.2.1. After curing, measure the distance the material has sagged or slumped below the scribed line and record.

5.5 *Density*—The density of the cured film adhesive shall be tested in accordance with Test Methods D 792, Method A (Displacement of Water).

5.6 *Shear Strength Test (Core Splice)*:

5.6.1 The following materials shall be used to fabricate sandwich specimens of 76-mm (3-in.) width by 381-mm (15-in.) length by 53-mm (2.10-in.) thickness size:

5.6.1.1 1.3-mm (0.050-in.) thick 5052-H34 or 6061-T6 aluminum skins (Federal Standard QQ-A-250/8d or QQ-A-250/11d, respectively, or Specification B 209).

5.6.1.2 51-mm (2-in.) thick Type IV honeycomb core meeting Specification E 1091.

5.6.1.3 Structural film adhesive meeting Specification E 865.

5.6.1.4 1.3-mm (0.050-in.) thick core splice adhesive as specified in this specification.

5.6.2 Three individual sandwich specimens shall be fabricated with core splice adhesive being used to form a splice in the L (longitudinal) direction of the core across the 76-mm (3-in.) specimen width at the location specified in 5.6.3 (see Specification E 1091 for orientation of core material). Note that aluminum skins shall be cleaned and etched in accordance with Practice E 864 and bonded to the core in accordance with Practice E 874.

5.6.3 Sandwich specimens shall be tested at  $24 \pm 2.8^\circ\text{C}$  ( $75 \pm 5^\circ\text{F}$ ) in accordance with Test Method C 393 with modifications as stated herein, using a 305-mm (12-in.) span (see Fig. 3). The two upper loading points and the two support points shall employ 51 by 76 by 6.4-mm (2 by 3 by 1/4-in.) loading blocks. The upper loading points shall be located at the

one-third span positions. The splice must be positioned at the maximum shear load location, which is approximately 51 mm (2 in.) from the centerline of either bottom support point as shown in Fig. 4. The load shall be applied through a constant rate of movement of the head of the testing machine, and at such a rate that the maximum load will occur between 3 and 5 min.

5.7 *Tube Shear Test*:

5.7.1 Tube shear specimens shall be fabricated from drawn aluminum concentric tubes made from 5052-O, QQ-A-250/4 or alloy of comparable compressive strength. The outer tube shall have a 25-mm (1-in.) outside diameter and the inner tube a 13-mm (1/2-in.) outside diameter. Both tubes shall be 225-mm (9-in.) long and have a wall thickness of 1.2-mm (0.049-in.).

5.7.2 Following cutting to length and deburring, aluminum tubes shall be cleaned and etched in accordance with Practice E 864.

5.7.3 The quantity of adhesive required to fill the tube shear assembly annular volume of approximately  $65 \text{ cm}^3$  ( $4 \text{ in.}^3$ ) must be determined experimentally for each adhesive. This quantity normally falls in the range of 35 to 45 g depending on its composition. Use the same quantity  $\pm 1 \text{ g}$  for all tube shear tests with the same adhesive.

5.7.4 Measure the thickness of the uncured core splice adhesive. Do not use if the thickness is under 1.1 mm (0.045 in.). If the thickness is between 1.1 mm and 1.7 mm (0.045 in. to 0.065 in.) cut a 22 by 15 cm (approx. 8.5 by 6 in.) piece of core splice adhesive. Weigh this sample to the nearest 0.1 g (tare the scale with liner paper pulled from one side of the sample, then weigh the sample with the liner paper still attached on one side). Reduce the mass of the  $22 \times 15 \text{ cm}$  piece of core splice adhesive by trimming 22 cm strips from the long edge until the mass determined in 5.7.3 remains. Discard the trimmed strips. If 2.54-mm (0.100-in.) thick core splice adhesive is used, rectangular dimensions that provide the mass determined in 5.7.3 must be calculated.

5.7.5 Using the remaining rectangle of core splice adhesive from 5.7.4 that has been trimmed to the proper weight, place

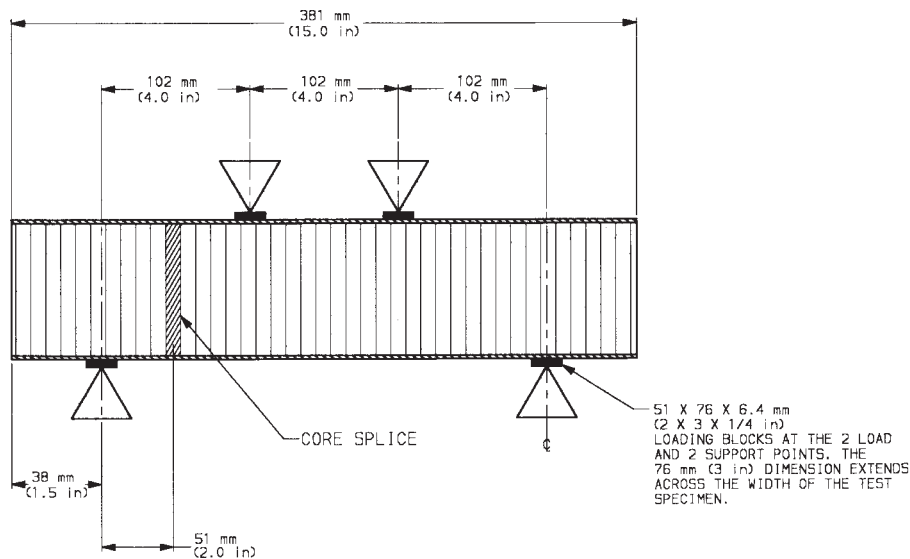

FIG. 4 Beam Shear Test of Core Splice Sandwich Specimen

the inner tube along the long dimension of the adhesive and roll the adhesive around the inner tube.

5.7.6 Twist the large outer tube into one of the fixture blocks shown in Fig. 5. Be sure to place suitable flow retardant cloth, that is, nylon peel ply or perforated TFE-fluorocarbon between tube and fixture blocks. This will prevent core splice from foaming out vent holes in the ends of the fixture blocks during cure.

5.7.7 Slide the inner tube containing the core splice adhesive inside outer tube center and push into place until both tubes are seated in fixture block and tubes are even on the open end. Place flow retardant cloth over the open end and install the other fixture block making sure the tubes are seated and in the center of the fixture block ends. Hand tighten the wing nuts.

5.7.8 Place fixture horizontally in a preheated oven and cure in accordance with 4.3.2.1.

5.7.9 After the core splice adhesive has been cured and has been cooled to room temperature, cut test specimens  $13 \pm 0.51$  mm-long (approx.  $0.5 \pm 0.04$  in.) with flat face normal to the tube axis. Discard the specimen on each end. Deburr the remaining specimens.

NOTE 3—A convenient way to cut test specimens is by using the tube shear cutting fixture shown in Fig. 6.

5.7.10 Test by shearing the inner tube out of the outer tube using the tube shear test fixture shown in Fig. 7.

5.7.11 All tube shear tests shall be performed at room temperature. Apply load-to-failure at a cross-head rate of  $1.52 \text{ mm} \pm 0.51 \text{ mm/min}$  ( $0.06 \pm 0.02 \text{ in./min}$ ).

5.7.12 Calculate the shear strength by using the outer surface of the inner tube as the shear surface ( $\pi \times \text{diameter} \times \text{length}$ ).

5.7.13 Test 3 randomly selected specimens from each tube. Two tubes from each batch are required for batch certification. Pass/fail test criteria are listed in Table 1 and Table 2.

## 6. Inspection

6.1 *Responsibility for Inspection*—Unless otherwise specified in the contract or purchase order, the supplier is responsible for the performance of all inspection requirements as specified herein. Except as otherwise specified in the contract or order, the supplier shall use his own or any other facilities suitable for the performance of inspection requirements specified herein unless disapproved by the purchaser. The purchaser has the right to perform any of the inspections described in the specification where such inspections are necessary to ensure compliance with the requirements.

6.2 *Classification of Inspections*—The inspection requirements specified herein are classified as follows:

6.2.1 *Qualification Inspection* (see 6.3),

6.2.2 *Quality Conformance Inspection* (see 6.4),

6.3 *Qualification Inspection:*

6.3.1 *Qualification Test*—Unless otherwise specified by the purchaser, adhesives that have not passed all the tests specified in Table 1, or that have previously passed the tests but have subsequently been modified in any manner, must be tested against this specification and shown to meet its requirements.

6.3.1.1 *Instruction Sheet*—A dated, coded, and titled instruction sheet that outlines instructions for use of the adhesive shall be supplied by the manufacturer. These instructions shall be forwarded with the test report (see 6.3.2) when requesting qualification. In addition, a copy of the instruction sheet shall accompany each shipment of the adhesive. At the option of the purchaser, the tests as specified in Section 5 shall be repeated at any time on material previously found satisfactory.

6.3.2 *Test Report*—The manufacturer shall furnish a dated and numbered report giving the results of all tests listed in Table 1. The individual and average values for the tests shall be reported. The test report shall cover all requirements of Section 4. Exact information as to how the individual specimens were fabricated, including component materials, component material preparation, and their processing into samples, as well as complete testing information for each test, such as test apparatus and cross head speeds, shall be reported. The report shall certify that the application of the adhesive conformed to the description given in the instruction sheet.

6.4 *Quality Conformance Inspection Tests*—Samples of each lot of adhesive delivered on contract or order shall be subjected to the tests specified in Table 2. Test reports, in duplicate, shall be furnished for all tests specified in this specification and shall be signed by an authorized representative of the laboratory making the tests.

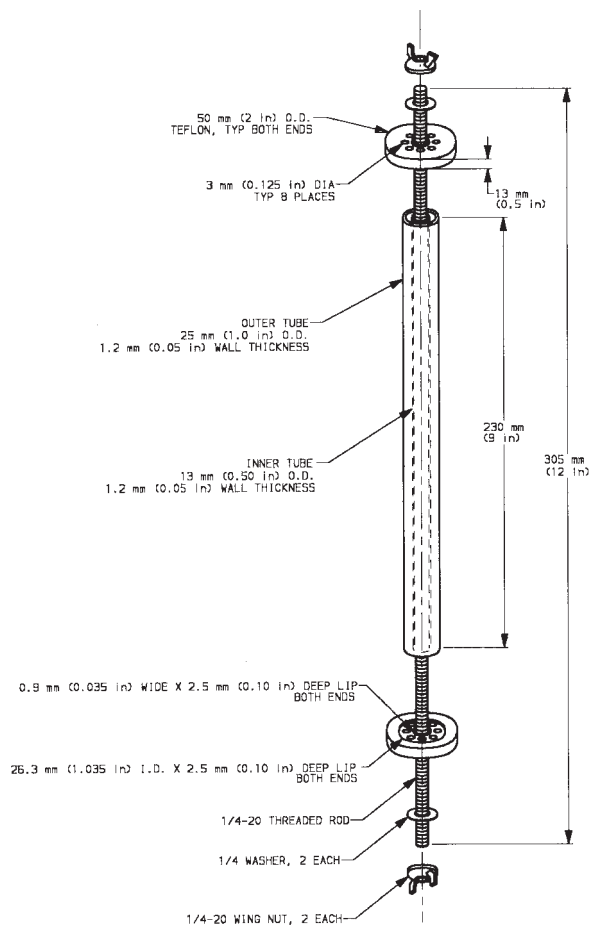

FIG. 5 Tube Shear Lay-up Fixture

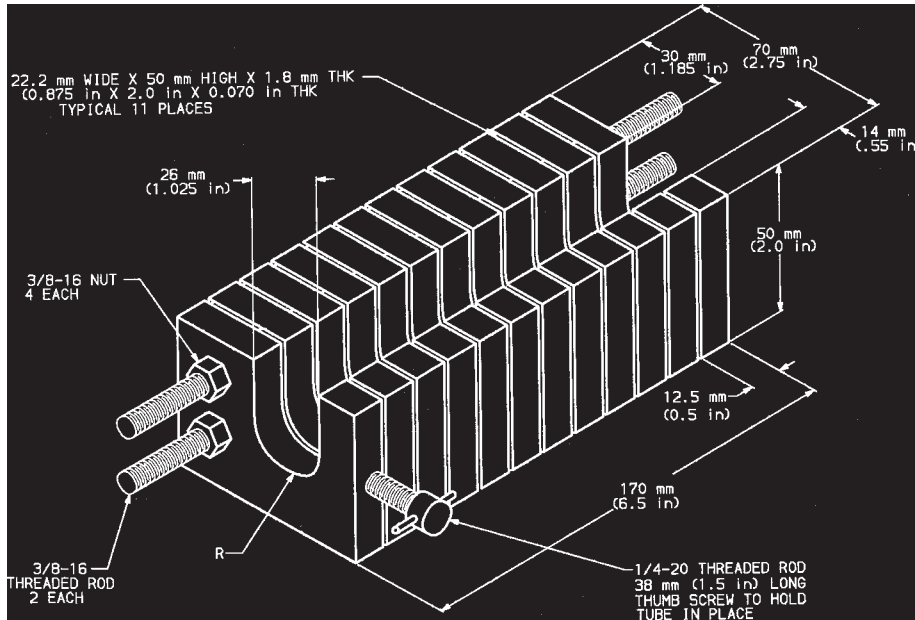

FIG. 6 Tube Shear Cutting Fixture

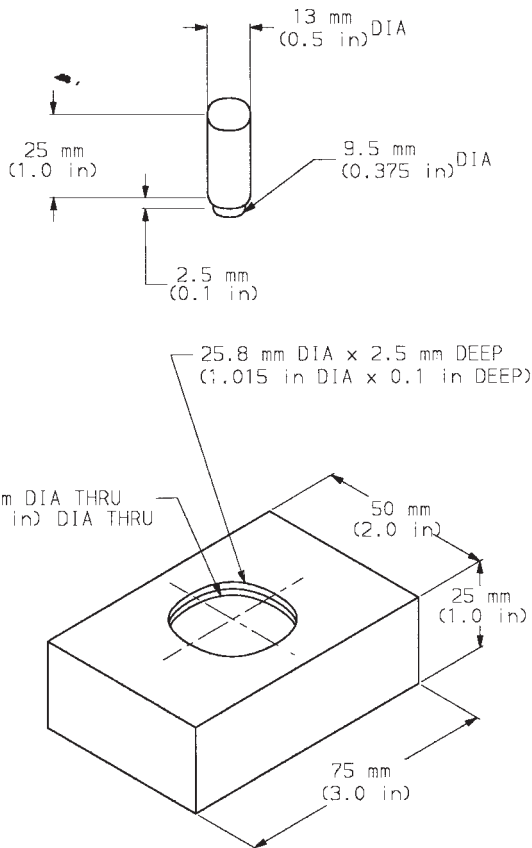

FIG. 7 Tube Shear Test Fixture

TABLE 2 Physical Properties Quality Conformance Requirements

Test	Reference Paragraph	Requirements
Volatility	5.2	1 % Maximum
Expansion	5.3	1.75 minimum ratio
Sag for 1.27 mm (0.05 in.) uncured thickness	5.4	3.8 mm (0.015 in.) maximum
Sag for 2.54 mm (0.1 in.) uncured thickness	5.4	12.7 mm (0.500 in.) maximum
Density (cured)	5.5	0.8 g per cm <sup>3</sup> (50 lb/ft <sup>3</sup> ) maximum
Tube shear (core splice integrity)	5.7	Minimum average 4.13 MPa (600 psi) Minimum individual 3.1 MPa (450 psi)

**7. Packaging and Package Marking**

7.1 Packaging—Packaging shall be in accordance with the supplier’s standard practices and applicable regulation.

7.1.1 Specification designation and year of issue,

- 7.1.2 Date of manufacture (month and year),
- 7.1.3 Manufacturer’s name and address,
- 7.1.4 Manufacturer’s product trade name,
- 7.1.5 Manufacturer’s product type designation,
- 7.1.6 Manufacturer’s batch/lot designation,
- 7.1.7 Contract number,
- 7.1.8 Date of shipment,
- 7.1.9 Expiration date,
- 7.1.10 Manufacturer’s recommended storage temperature range,
- 7.1.11 Quantity contained,
- 7.1.12 Film thickness, and
- 7.1.13 Manufacturer’s certification that the batch and unit lot meet the requirements of this specification. (See Appendix of Practice E 874 for definitions.)

**8. Keywords**

8.1 adhesive; core splice; honeycomb; panel; relocatable structure; sandwich panel; structure

*ASTM International takes no position respecting the validity of any patent rights asserted in connection with any item mentioned in this standard. Users of this standard are expressly advised that determination of the validity of any such patent rights, and the risk of infringement of such rights, are entirely their own responsibility.*

*This standard is subject to revision at any time by the responsible technical committee and must be reviewed every five years and if not revised, either reapproved or withdrawn. Your comments are invited either for revision of this standard or for additional standards and should be addressed to ASTM International Headquarters. Your comments will receive careful consideration at a meeting of the responsible technical committee, which you may attend. If you feel that your comments have not received a fair hearing you should make your views known to the ASTM Committee on Standards, at the address shown below.*

*This standard is copyrighted by ASTM International, 100 Barr Harbor Drive, PO Box C700, West Conshohocken, PA 19428-2959, United States. Individual reprints (single or multiple copies) of this standard may be obtained by contacting ASTM at the above address or at 610-832-9585 (phone), 610-832-9555 (fax), or [service@astm.org](mailto:service@astm.org) (e-mail); or through the ASTM website ([www.astm.org](http://www.astm.org)).*