



Standard Test Method for Index Puncture Resistance of Geotextiles, Geomembranes, and Related Products¹

This standard is issued under the fixed designation D 4833; the number immediately following the designation indicates the year of original adoption or, in the case of revision, the year of last revision. A number in parentheses indicates the year of last reapproval. A superscript epsilon (ϵ) indicates an editorial change since the last revision or reapproval.

^{ε1} NOTE—Table 1 was editorially corrected from a one-sided table to a two-sided table in April 2002.

1. Scope

1.1 This test method is used to measure the index puncture resistance of geotextiles, geomembranes, and related products.

1.2 The use of Test Method D 4833 may be inappropriate for testing some woven geotextiles or related products which have large openings (Note 1).

NOTE 1—Geonets and geogrids cannot be tested using this test method.

1.3 The values stated in SI units are to be regarded as the standard. The values provided in inch-pound units are for information only.

1.4 *This standard does not purport to address all of the safety concerns, if any, associated with its use. It is the responsibility of the user of this standard to establish appropriate safety and health practices and determine the applicability of regulatory limitations prior to use.*

2. Referenced Documents

2.1 ASTM Standards:

D 76 Specification for Tensile Testing Machines for Textiles²

D 123 Terminology Relating to Textiles²

D 1776 Practice for Conditioning and Testing Textiles²

D 2905 Practice for Statements on Number of Specimens for Textiles²

D 4354 Practice for Sampling of Geosynthetics for Testing³

D 4439 Terminology for Geosynthetics³

3. Terminology

3.1 Definitions:

3.1.1 *atmosphere for testing geotextiles, n*—air maintained at a relative humidity of $65 \pm 5\%$ and a temperature of $21 \pm 2^\circ\text{C}$ ($70 \pm 4^\circ\text{F}$).

3.1.2 *geomembrane, n*—very low permeability synthetic

membrane liners or barriers used with any geotechnical engineering related material so as to control fluid migration in a man-made project, structure, or system.

3.1.3 *geotextile, n*—any permeable textile used with foundations, soil, rock, earth, or any other geotechnical material as an integral part of man-made project, structure, or system.

3.1.4 *index test, n*—a test procedure which may contain a known bias but which may be used to establish an order for a set of specimens with respect to the property of interest.

3.1.5 *puncture resistance (F), n*—the inherent resisting mechanism of the test specimen to the failure by a penetrating or puncturing object.

3.2 For definitions of other textile terms used in this standard, refer to Terminology D 123.

3.3 For definitions of other terms relating to geotextiles used in this standard, refer to Terminology D 4439.

4. Summary of Test Method

4.1 A test specimen is clamped without tension between circular plates of a ring clamp attachment secured in a tensile testing machine. A force is exerted against the center of the unsupported portion of the test specimen by a solid steel rod attached to the load indicator until rupture of the specimen occurs. The maximum force recorded is the value of puncture resistance of the specimen.

5. Significance and Use

5.1 This test method is an index test for determining the puncture resistance of geotextiles, geomembranes, and related products. The use of this test method is to establish an index value by providing standard criteria and a basis for uniform reporting.

5.2 This test method is considered satisfactory for acceptance testing of commercial shipments of geotextiles, geomembranes, and related materials since the test method has been used extensively in the trade for acceptance testing.

5.2.1 In case of a dispute arising from differences in reported test results when using this test method for acceptance testing of commercial shipments, the purchaser and the supplier should conduct comparative tests to determine if there is

¹ This test method is under the jurisdiction of ASTM Committee D35 on Geosynthetics and is the direct responsibility of Subcommittee D35.01 on Mechanical Properties.

Current edition approved Feb. 10, 2000. Published May 2000. Originally published as D4833–88. Last previous edition D4833–88(96)^{ε1}.

² *Annual Book of ASTM Standards*, Vol 07.01.

³ *Annual Book of ASTM Standards*, Vol 04.13.

a statistical bias between their laboratories. Competent statistical assistance is recommended for the investigation of bias. As a minimum, the two parties should take a group of test specimens that are as homogeneous as possible and that are from a lot material of the type in question. The test specimens should then be randomly assigned in equal numbers to each laboratory for testing. The average results from the two laboratories should be compared using Student's *t*-test for unpaired data and an acceptable probability level chosen by the two parties before the testing is begun. If a bias is found, either its cause must be found and corrected or the purchaser and the supplier must agree to interpret future test results in the light of the known bias.

6. Apparatus

6.1 *Tensile/Compression Testing Machine*, of the constant-rate-of extension (CRE) type, with autographic recorder conforming to the requirements of Specification D 76. See Fig. 1.

6.2 *Ring Clamp Attachment*, consisting of concentric plates with an open internal diameter of 45 ± 0.025 mm (1.772 ± 0.001 in.), capable of clamping the test specimen without slippage. A suggested clamping arrangement is shown in Fig. 1 and Fig. 2. The external diameter is suggested to be 100 ± 0.025 mm (3.937 ± 0.001 in.). The diameter of the six holes used for securing the ring clamp assembly is suggested to be 8 mm (0.135 in.) and equally spaced at a radius of 37 mm (2.95 in.). The surfaces of these plates can consist of grooves with O-rings or coarse sandpaper bonded onto opposing surfaces.

6.3 *Solid Steel Rod*, with a diameter of 8 ± 0.1 mm (0.315 ± 0.004 in.) having a flat end with a $45^\circ = 0.8$ mm (0.315 in.) chamfered edge contacting the test specimen's surface. See Fig. 1 and Fig. 3.

7. Sampling

7.1 *Lot Sample*—Divide the product into lots and take the lot sample as directed in Practice D 4354.

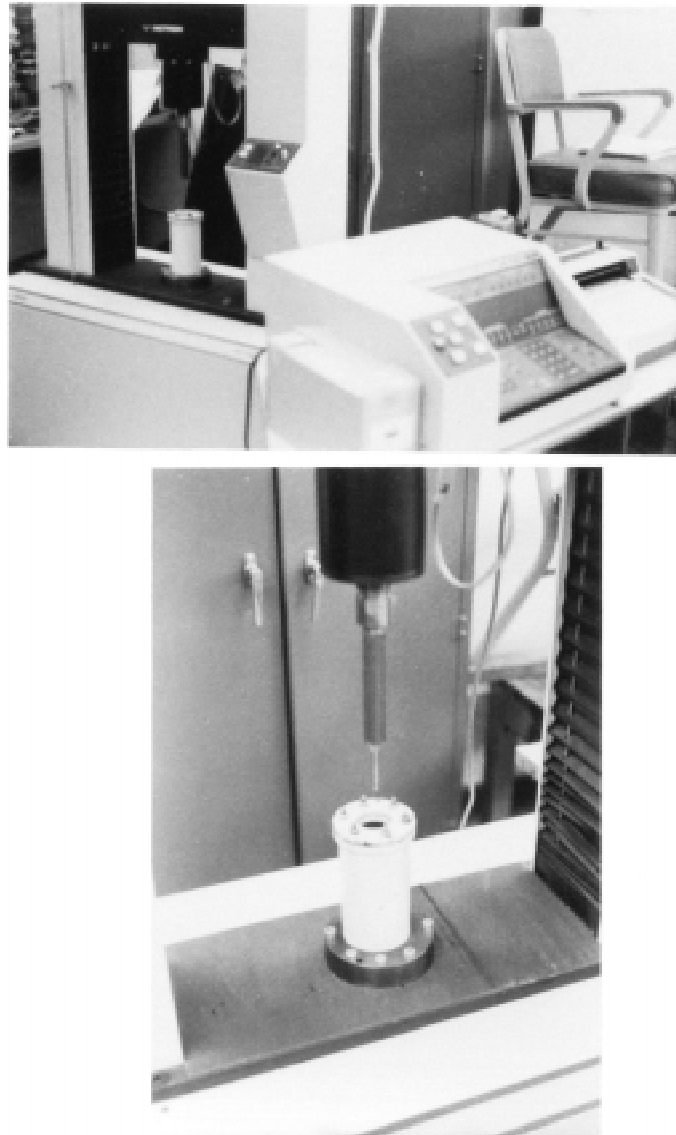

FIG. 1 Photographs of Test Setup and Fixture

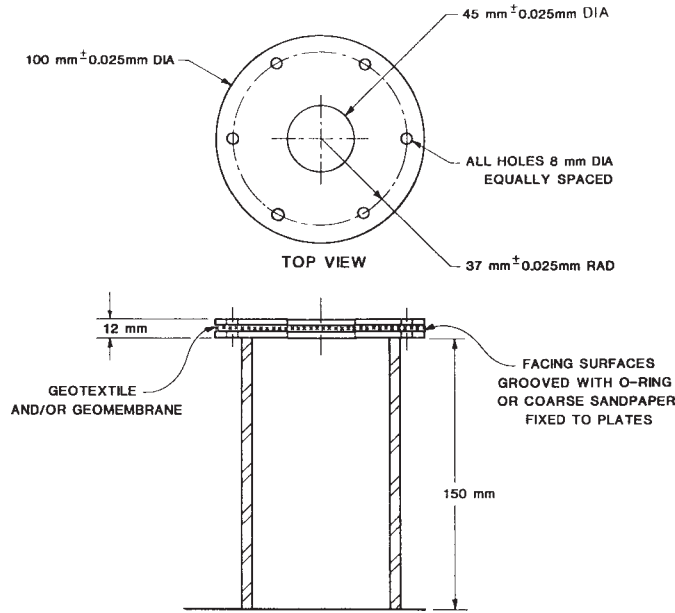

FIG. 2 Test Fixture Detail (Not to Scale)

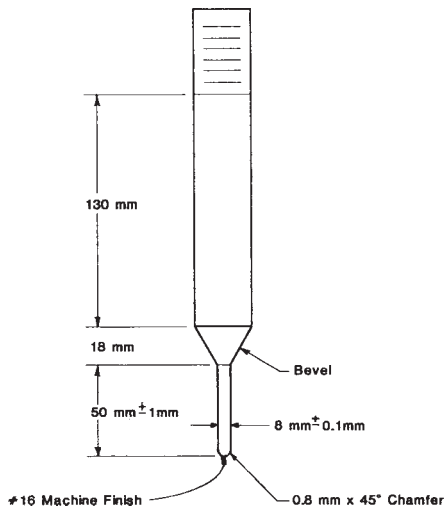

FIG. 3 Test Probe Detail (Not to Scale)

7.2 *Laboratory Sample*—For the laboratory sample, take a swatch extending the full width of the geotextile, of sufficient length along the selvage, from each sample roll so that the requirements of 7.3 and 8.1 can be met. Take a sample that will exclude material from the outer wrap and inner wrap around the core unless the sample is taken at the production site, then inner and outer wrap material may be used.

7.3 *Test Specimens*—Select from the laboratory sample the number of specimens directed in Section 8. Minimum specimen diameter is 100 mm (4 in.) to facilitate clamping. Space the specimens along a diagonal on the unit of the laboratory sample. Take no specimens nearer the selvage or edge of the geotextile sample than 1/10 the width of the geotextile sample.

8. Number of Specimens

8.1 *Reliable Estimate of v* —When there is a reliable estimate of v based on extensive past records for similar materials tested in the user's laboratory, calculate the number of speci-

mens per unit in the laboratory sample using Eq 1:

$$n = (tv/a)^2 = (tv)^2/36 \quad (1)$$

where:

- n = number of specimens (rounded upward to a whole number),
- v = reliable estimate of the coefficient of variation for individual observations on similar materials in the user's laboratory under conditions of single-operator precision,
- t = value of Student's test for two-sided limits (see Table 1) a 95 % probability level, and the degrees of freedom associated with the estimate of v , and
- A = 6 % of the average, the value of the allowable variable.

8.2 *No Reliable Estimate of v* —When there is no reliable estimate of v in the user's laboratory, specify the fixed number of 15 specimens per swatch in the laboratory sample. This number of specimens is calculated using $v = 10$ % of the average, which is a somewhat larger value of v than is usually

TABLE 1 Values of Student's t for Two-Sided Limits and the 95 % Probability^A

df	$t_{.025}$	df	$t_{.025}$	df	$t_{.025}$
1	12.706	11	2.201	21	2.080
2	4.303	12	2.179	22	2.074
3	3.182	13	2.160	23	2.069
4	2.776	14	2.145	24	2.064
5	2.571	15	2.131	25	2.060
6	2.447	16	2.120	26	2.056
7	2.365	17	2.110	27	2.052
8	2.306	18	2.101	28	2.048
9	2.262	19	2.093	29	2.045
10	2.228	20	2.086	inf.	1.960

^AValues in this table were calculated using Hewlett Packard HP 67/97 Users' Library Programs 03848D, "One-Sided and Two-Sided Critical Values of Student's t " and 00350D, "Improved Normal and Inverse Distribution." For values at other than the 95 % probability level, see published tables of critical values of Student's t in any standard statistical text. Further use of this table is defined in Practice D 2905.

found in practice. When a reliable estimate of ν for the user's laboratory becomes available, Eq 1 will usually require fewer than 15 specimens per swatch in the laboratory sample.

9. Conditioning

9.1 Bring the specimens to moisture equilibrium in the atmosphere for testing geotextiles (3.1). Equilibrium is considered to have been reached when the increase in the mass of the specimen, in successive weighings made at intervals of not less than 2 h, does not exceed 0.1 % of the mass of the specimen. In general, most geotextiles, geomembranes, and related products contain more moisture when received than they will after reaching moisture equilibrium.

NOTE 2—It is recognized that in practice, geotextile materials are frequently not weighed to determine when moisture equilibrium has been reached. While such a method cannot be accepted in cases of dispute, it may be sufficient in routine testing to expose the material to the standard atmosphere for a reasonable period of time before the specimens are tested. A time of at least 24 h has been found acceptable in most cases. However, certain fibers may contain more moisture upon receipt than after conditioning. When this is known, a preconditioning cycle, as described in Practice D 1776, may be agreed upon by the contractual parties for routine testing.

10. Procedure

10.1 Select the load range of the tensile/compression testing machine such that the rupture occurs between 10 and 90 % of the full-scale load.

10.2 Center and secure the specimen between the holding plates ensuring that the test specimen extends to or beyond the outer edges of the clamping plates.

10.3 Test at a machine speed of 300 ± 10 mm (12 in. \pm 1/2 in.)/min until the puncture rod completely ruptures the test specimen.

NOTE 3—The rate of testing specified is not an indication of the performance of the specimen for its end use.

10.4 Read the puncture resistance from the greatest force registered on the recording instrument during the test. For the

testing of composite geotextile or composite geomembrane materials, there may be a double peak. If so, the initial value should be reported even if the second peak is higher than the first one.

10.5 For geotextile testing, if the yarns fail to break as a result of the slippage of the specimen from the ring clamp or if the probe slips between the yarns without causing yarn breakage, discard the result and test another specimen.

11. Calculation

11.1 Calculate the average puncture resistance and standard deviation for all tests as read directly from the recording instrument.

12. Report

12.1 State that the specimens were treated as directed in Test Method D 4833.

12.2 Report on the following information:

12.2.1 The method of holding the test specimen in the clamping device.

12.2.2 The average puncture resistance of the specimens tested.

12.2.3 The coefficient of variation (if known) and standard deviation for each group of specimens.

12.2.4 The variation, if any, from the described test method.

13. Precision and Bias

13.1 *Precision*—The precision of the procedure in this test method for measuring the puncture resistance of geotextiles, geomembranes, and related materials is being established.

13.2 *Bias*—The procedure in this test method for measuring the puncture resistance of geotextiles, geomembranes, and related materials has no bias because the value of that property can be defined only in terms of a test method.

14. Keywords

14.1 geomembranes; geotextiles; puncture; puncture resistance

ASTM International takes no position respecting the validity of any patent rights asserted in connection with any item mentioned in this standard. Users of this standard are expressly advised that determination of the validity of any such patent rights, and the risk of infringement of such rights, are entirely their own responsibility.

This standard is subject to revision at any time by the responsible technical committee and must be reviewed every five years and if not revised, either reapproved or withdrawn. Your comments are invited either for revision of this standard or for additional standards and should be addressed to ASTM International Headquarters. Your comments will receive careful consideration at a meeting of the responsible technical committee, which you may attend. If you feel that your comments have not received a fair hearing you should make your views known to the ASTM Committee on Standards, at the address shown below.

This standard is copyrighted by ASTM International, 100 Barr Harbor Drive, PO Box C700, West Conshohocken, PA 19428-2959, United States. Individual reprints (single or multiple copies) of this standard may be obtained by contacting ASTM at the above address or at 610-832-9585 (phone), 610-832-9555 (fax), or service@astm.org (e-mail); or through the ASTM website (www.astm.org).