



Designation: D 4885 – 88 (Reapproved 1995)

AMERICAN SOCIETY FOR TESTING AND MATERIALS  
100 Barr Harbor Dr., West Conshohocken, PA 19428  
Reprinted from the Annual Book of ASTM Standards. Copyright ASTM

## Standard Test Method for Determining Performance Strength of Geomembranes by the Wide Strip Tensile Method<sup>1</sup>

This standard is issued under the fixed designation D 4885; the number immediately following the designation indicates the year of original adoption or, in the case of revision, the year of last revision. A number in parentheses indicates the year of last reapproval. A superscript epsilon ( $\epsilon$ ) indicates an editorial change since the last revision or reapproval.

### 1. Scope

1.1 This test method covers the determination of the performance strength of synthetic geomembranes by subjecting wide strips of material to tensile loading.

1.2 This test method covers the measurement of tensile strength and elongation of geomembranes and includes directions for calculating initial modulus, offset modulus, secant modulus, and breaking toughness.

1.3 The basic distinctions between this test method and other methods measuring tensile strength of geomembranes are the width of the specimens tested and the speed of applied force. The greater width of the specimens specified in this test method minimizes the contraction edge effect (necking) which occurs in many geosynthetics and provides a closer relationship to actual material behavior in service. The slower speed of applied strain also provides a closer relationship to actual material behavior in service.

1.4 As a performance test, this method will be used relatively infrequently, and to test large lots of material. This test method is not intended for routine quality control testing of geomembranes.

1.5 *This standard does not purport to address all of the safety concerns, if any, associated with its use. It is the responsibility of the user of this standard to establish appropriate safety and health practices and determine the applicability of regulatory limitations prior to use.*

1.6 The values stated in SI units are to be regarded as the standard. The inch-pound values stated in parentheses are provided for information only.

### 2. Referenced Documents

#### 2.1 ASTM Standards:

D 76 Specification for Tensile Testing Machines for Textiles<sup>2</sup>

D 123 Terminology Relating to Textiles<sup>2</sup>

D 751 Methods of Testing Coated Fabrics<sup>3</sup>

<sup>1</sup> This test method is under the jurisdiction of ASTM Committee D-35 on Geosynthetics and is the direct responsibility of Subcommittee D35.10 on Geomembranes.

Current edition approved Nov. 25, 1988. Published January 1988.

<sup>2</sup> Annual Book of ASTM Standards, Vols 07.01 and 07.02.

<sup>3</sup> Annual Book of ASTM Standards, Vol 09.02.

D 882 Test Methods for Tensile Properties of Thin Plastic Sheeting<sup>4</sup>

D 1593 Specification for Nonrigid Vinyl Chloride Plastic Sheeting<sup>4</sup>

D 1909 Table of Commercial Moisture Regains for Textile Fibers<sup>2</sup>

D 4354 Practice for Sampling of Geosynthetics for Testing<sup>5</sup>

D 4439 Terminology for Geosynthetics<sup>5</sup>

### 3. Terminology

#### 3.1 Definitions:

3.1.1 *atmosphere for testing geomembranes, n*—air maintained at a relative humidity of 50 to 70 % and a temperature of  $21 \pm 2^\circ\text{C}$  ( $70 \pm 4^\circ\text{F}$ ).

3.1.1.1 *Discussion*—Within the range of 50 to 70 % relative humidity, moisture content is not expected to affect the tensile properties of geomembrane materials. In addition, geotextile standard test methods restrict the range of relative humidity to  $65 \pm 5\%$ , while geomembrane standard test methods restrict the range of relative humidity to  $55 \pm 5\%$ . The restricted range in this test method is made broader to reduce the need for testing laboratories to change laboratory conditions, and considering the lack of expected effect of moisture on geomembranes. The user should consult Table D1909 to resolve questions regarding moisture regains of textile fibers, especially if the user is testing a new or unknown material.

3.1.2 *breaking force, (F), J, n*—the force at failure.

3.1.3 *breaking toughness, T, (FL<sup>-1</sup>), Jm<sup>-2</sup>, n*—for geosynthetics, the actual work per unit volume of a material corresponding to the breaking force.

3.1.3.1 *Discussion*—Breaking toughness is proportional to the area under the force-elongation curve from the origin to the breaking point (see also, work-to-break). Breaking toughness is calculated from work-to-break and width of a specimen. *In geomembranes*, breaking toughness is often expressed as force per unit width of material in inch-pound values. In other materials, breaking toughness is often expressed as work per unit mass of material.

3.1.4 *corresponding force, n*—synonym for force at specified elongation.

3.1.5 *elastic limit, n*— *in mechanics*, the stress intensity at

<sup>4</sup> Annual Book of ASTM Standards, Vol 08.01.

<sup>5</sup> Annual Book of ASTM Standards, Vol 04.09.

which stress and deformation of a material subjected to an increasing force cease to be proportional; the limit of stress within which a material will return to its original size and shape when the force is removed, and hence, not a permanent set.

3.1.6 *failure, n*—an arbitrary point beyond which a material ceases to be functionally capable of its intended use.

3.1.6.1 *Discussion*—In wide strip tensile testing of geosynthetics, failure occurs either at the rupture point or at the yield point in the force-elongation curve, whichever occurs first. For reinforced geomembranes, failure occurs at rupture of the reinforcing fabric. For nonreinforced geomembranes which exhibit a yield point, such as polyethylene materials, failure occurs at the yield point. Even though the geomembrane continues to elongate, the force-elongation relationship has been irreversibly altered. For nonreinforced geomembranes which do not exhibit a yield point, such as plasticized PVC materials, failure occurs at rupture of the geomembrane.

3.1.7 *force at specified elongation, FASE, n*—a force associated with a specific elongation on the force-elongation curve. (Synonym for corresponding force.)

3.1.8 *force-elongation curve, n*—in a tensile test, a graphical representation of the relationship between the magnitude of an externally applied force and the change in length of the specimen in the direction of the applied force. (Synonym for stress-strain curve.)

3.1.9 *geomembrane, n*—An essentially impermeable geosynthetic used with foundation soil, rock, earth, or any other geotechnical engineering related material as an integral part of a man-made project, structure, or system.

3.1.9.1 *Discussion*—Other names under which geomembranes are recognized include: flexible membrane liners (fml's), liners, and membranes.

3.1.10 *index test, n*—a test procedure which may contain a known bias, but which may be used to establish an order for a set of specimens with respect to the property of interest.

3.1.11 *inflection point, n*—the first point of the force-elongation curve at which the second derivative equals zero.

3.1.11.1 *Discussion*—The inflection point occurs at the first point on the force-elongation curve at which the curve ceases to curve upward and begins to curve downward (or vice versa).

3.1.12 *initial tensile modulus,  $J_i$ , ( $FL^{-1}$ ),  $Nm^{-1}$ ,  $n$* —for geosynthetics, the ratio of the change in force per unit width to the change in elongation of the initial portion of a force-elongation curve.

3.1.13 *offset modulus,  $J_o$ , ( $FL^{-1}$ ),  $Nm^{-1}$ ,  $n$* —for geosynthetics, the ratio of the change in force per unit width to the change in elongation below an arbitrary offset point at which there is a proportional relationship between force and elongation, and above the inflection point on the force-elongation curve.

3.1.14 *performance test, n*—a test

which simulates in the laboratory as closely as practicable selected conditions experienced in the field and which can be used in design. (Synonym for design test.)

3.1.15 *secant modulus,  $J_{sec}$ , ( $FL^{-1}$ ),  $Nm^{-1}$ ,  $n$* —for geosynthetics, the ratio of change in force per unit width to the change in elongation between two points on a force-elongation curve.

3.1.16 *tensile, adj*—capable of tensions, or relating to tension of a material.

3.1.17 *tensile modulus,  $J$ , ( $FL^{-1}$ ),  $Nm^{-1}$ ,  $n$* —for geosynthetics, the ratio of the change in tensile force per unit width to a corresponding change in elongation.

3.1.18 *tensile strength, n*—the maximum resistance to deformation developed by a specific material when subjected to tension by an external force.

3.1.19 *tensile test, n*—for geosynthetics, a test in which a material is stretched uniaxially to determine the force-elongation characteristics, the breaking force, or the breaking elongation.

3.1.20 *tension, n*—the force that produces a specified elongation.

3.1.21 *wide strip tensile test, n*—for geosynthetics, a tensile test in which the entire width of a 200 mm (8.0 in.) wide specimen is gripped in the clamps and the gage length is 100 mm (4.0 in.).

3.1.22 *work-to-break,  $W$ , ( $LF$ ),  $J$ ,  $n$* —in tensile testing, the total energy required to rupture a specimen.

3.1.22.1 *Discussion*—For geomembranes, work-to-break is proportional to the area under the force-elongation curve from the origin to the breaking point.

3.1.23 *yield point, n*—in geosynthetics, the point on the force-elongation curve at which the first derivative equals zero (the first maximum).

3.1.24 For definitions of other terms used in this test method, refer to Terminologies D 123 and D 4439.

#### 4. Summary of Test Method

4.1 A relatively wide specimen is gripped across its entire width in the clamps of a constant rate of extension type tensile testing machine operated at a prescribed rate of extension, applying a uniaxial load to the specimen until the specimen ruptures. Tensile strength, elongation, initial and secant modulus, and breaking toughness of the test specimen can be calculated from machine scales, dials, recording charts, or an interfaced computer.

#### 5. Significance and Use

5.1 This test method is a performance test intended as a design aid used to determine the ability of geomembranes to withstand the stresses and strains imposed under design conditions. This test method assists the design engineer in comparing several candidate geomembranes under specific test conditions.

5.2 As a performance test, this method is not intended for routine acceptance testing of commercial shipments of geomembranes. Other more easily performed test methods, such as Method D 751 or Test Method D 882, can be used for routine acceptance testing of geomembranes. This test method will be used relatively infrequently, and to establish performance characteristics of geomembrane materials.

5.2.1 There is no known correlation between this test method and index test methods, such as Method D 751.

5.3 All geomembranes can be tested by this method. Some modification of techniques may be necessary for a given geomembrane depending upon its physical make-up. Special adaptations may be necessary with strong geomembranes or

geomembranes with extremely slick surfaces, to prevent them from slipping in the clamps or being damaged by the clamps.

## 6. Apparatus

6.1 *Clamps*—A gripping system that minimizes (with the goal of eliminating) slippage, damage to the specimen, and uneven stress distribution. The gripping system shall extend to or beyond the outer edge of the specimen to be tested.<sup>6</sup>

6.2 *Specimen Cutter*—An appropriate cutting device which does not create irregularities or imperfections in the edge of the specimen. For wide strip specimens, a jig may not be necessary provided that the actual cut dimensions of the specimen can be measured accurately to the nearest 1.0 mm (0.04 in.), and that the width of the specimen is constant to within 1.0 mm (0.04 in.).

6.3 *Tensile Testing Machine*—A testing machine of the constant rate of extension type as described in Specification D 76 shall be used. The machine shall be equipped with a device for recording the tensile force and the amount of separation of the grips. Both of these measuring systems shall be accurate to  $\pm 2\%$  and, preferably, shall be external to the testing machine. The rate of separation shall be uniform and capable of adjustment within the range of the test.

## 7. Sampling

7.1 *Lot Sample*—Divide the product into lots and take the lot sample as directed in Practice D 4354.

7.2 *Laboratory Sample*—For the laboratory sample, take a full-width swatch approximately 1 m (40 in.) long in the machine direction from each roll in the lot sample. The sample may be taken from the end portion of a roll provided there is no evidence it is distorted or different from other portions of the roll.

7.3 *Test Specimens*—Take a total of twelve specimens from each swatch in the laboratory sample, with six specimens for tests in the machine direction and six specimens for tests in the cross-machine direction. Take the specimens from a diagonal on the swatch with no specimen nearer the edge of the geomembrane than 1/10 of the width of the geomembrane. Cut each specimen 200 mm (8.0 in.) wide by at least 200 mm (8.0 in.) long with the length precisely aligned with the direction in which the specimen is to be tested. The specimens must be long enough to extend completely through both clamps of the testing machine. Draw two parallel lines near the center of each specimen length that (1) are separated by 100 mm (4.0 in.), (2) extend the full width of the specimen, and (3) are exactly perpendicular to the length of the specimen. Exercise the utmost care in selecting, cutting, and preparing specimens to avoid nicks, tears, scratches, folds, or other imperfections that are likely to cause premature failure.

## 8. Conditioning

8.1 Expose the specimens to the standard atmosphere for testing geomembranes for a period long enough to allow the geomembrane to reach equilibrium with the standard atmo-

sphere. Consider the specimen to be at moisture equilibrium when the change in mass of the specimen in successive weighings made at intervals of not less than 2 h does not exceed 0.1 % of the mass of the specimen. Consider the specimen to be at temperature equilibrium after 1 h of exposure to the standard atmosphere for testing.

## 9. Procedure

9.1 Test adequately conditioned specimens. Conduct tests at a temperature of  $21 \pm 2^\circ\text{C}$  ( $70 \pm 4^\circ\text{F}$ ) and at a relative humidity of 50 to 70 %. The engineer may specify additional temperatures based upon expected service conditions for the installation.

9.2 Measure for the specimens thickness at the four corners of the specimen. Select specimens used in this procedure so that thickness is uniform to within 5 %. Measure thickness using either Specification D 1593 for nonreinforced geomembranes or Method D 751 for reinforced geomembranes.

9.3 Position the grips of the testing apparatus to a separation of  $100 \pm 3$  mm ( $4 \pm 0.1$  in.). At least one clamp should be supported by a free swivel or universal joint which will allow the clamp to rotate in the plane of the fabric. Select the force range of the testing machine so that the break occurs between 10 and 90 % of full scale load. Set the machine to a strain rate as directed in 9.6.

9.4 Mount the specimen centrally in the clamps. Do this by having the two lines, which were previously drawn  $100 \pm 3$  mm ( $4.0 \pm 0.1$  in.) apart across the width of the specimen as close as possible adjacent to the inside edges of the upper and lower jaw. The specimen length in the machine direction and the cross machine direction tests, respectively, must be parallel to the direction of application of force.

9.5 Start the tensile testing machine and the area measuring device, if used, and continue running the test to rupture. Stop the machine and reset to the initial gage position. Record and report the test results to three significant figures for each direction separately.

9.5.1 If a specimen slips in the jaws, or if for any reason attributed to faulty operation the result falls markedly below the average for the set of specimens, discard the result and test another specimen.

9.5.2 The decision to discard the results of a break shall be based upon observation of the specimen during the test and upon the inherent variability of the fabric. In the absence of other criteria for rejecting a so-called jaw break, any break occurring within 5 mm (0.25 in.) of the jaws which results in a value below 20 % of the average of all the other breaks shall be discarded. No other break shall be discarded unless the test is known to be faulty.

9.5.3 It is difficult to determine the precise reason why certain specimens break near the edge of the jaws. If a jaw break is caused by damage to the specimen by the jaws, then the results should be discarded. If, however, it is merely due to randomly distributed weak places, it is a perfectly legitimate result. In some cases, it may also be caused by a concentration of stress in the area adjacent to the jaws because they prevent the specimen from contracting in width as the load is applied. In these cases, a break near the edge of the jaws is inevitable

<sup>6</sup> Examples of clamping and extensometer systems which have been successfully used are shown in Appendixes.

and shall be accepted as a characteristic of the particular method of test.

9.5.4 If a geomembrane manifests any slippage in the jaws or if more than 24 % of the specimens break at a point within 5 mm (0.25 in.) of the edge of the jaw, then the jaws may be padded, or the surface of the jaw face may be modified. The user should exercise the utmost care to select jaw modifications which will not damage the test specimens in any manner. If any modifications of the jaw faces are used, state the method of modification in the report.

9.6 Measure the elongation of the geomembrane to three significant figures at any stated load by means of a suitable recording device at the same time as the tensile strength is determined.

9.6.1 Extensometers are preferred for measurement of elongation in geomembranes. Other means of measuring elongation should be calibrated against extensometers whenever possible. In any case, the means of measuring elongation should be clearly indicated in the report.<sup>6</sup>

9.7 Crosshead speed shall be 1 mm/min (0.04 in./min) unless specified otherwise by the engineer. The engineer may elect to specify higher crosshead speeds to simulate performance strength under shock loadings; for example, the engineer could specify 10 mm/min or 100 mm/min (0.39 in./min and 3.94 in./min, respectively). The same speed should be used to test differing materials in an attempt to evaluate the materials under identical strain conditions.

9.7.1 *Discussion*—The slowest of the speeds listed above will generally be used in this test method since these conditions will most closely simulate service conditions.

9.7.2 The sensitivity of this test method to crosshead speed is being investigated in ongoing round robin testing.

## 10. Calculation

10.1 *Tensile Strength*—Calculate the tensile strength for individual specimens; that is, calculate the maximum force per unit width to cause a specimen to rupture or yield as read directly from the testing machine expressed in N/m (lbf/m) of width, using Eq 1:

$$\alpha_f = F_f / W_s \quad (1)$$

where:

$\alpha_f$  = tensile strength of width, N/m (lbf/in.),  
 $F_f$  = observed breaking force, N (lbf), and  
 $W_s$  = specified specimen width, m (in.).

This value shall be reported to three significant figures.

NOTE 1—When tear or yield failure occurs, so indicate and calculate results based upon force and elongation at which tear or yield initiates, as reflected in the load-deformation curve.

10.2 *Percentage Elongation*—Calculate the percent elongation for individual specimens; that is, calculate the elongation of specimens, expressed as the percentage increase in length, based upon the initial gage length of the specimen using Eq 2 for XY type recorders, or Eq 3 for manual readings (ruler).

$$\epsilon_p = (E \times R \times 100) / (C \times L_g) \quad (2)$$

$$\epsilon_p = \Delta L \times 100 / L_g \quad (3)$$

where:

$\epsilon_p$  = elongation, % ,  
 $E$  = distance along the zero load axis from the point the curve leaves the zero load axis to a point of corresponding force, mm (in.),  
 $R$  = testing speed rate, m/min (in./min),  
 $C$  = recording chart speed, m/min (in./min),  
 $L_g$  = initial nominal gage length, mm (in.), and  
 $\Delta L$  = the unit change in length from a zero force to the corresponding measured force, mm (in.).

10.2.1 Gage marks or extensometers are preferred to define a specific test section of the specimen; when these devices are used, only the length defined by the gage marks or extensometers shall be used in the calculation. Gage marks must not damage the geomembrane.

### 10.3 Tensile Modulus:

10.3.1 *Initial Tangent Modulus*—Determine the location and draw a line tangent to the first straight portion of the force-elongation curve. At any point on this tangent line, measure the force and the corresponding elongation with respect to the zero load axis. Calculate initial tensile modulus in N/m (lbf/in.) of width using Eq 4.

$$J_i = (F \times 100) / (\epsilon_p \times W_s) \quad (4)$$

where:

$J_i$  = initial tangent modulus, N (lbf), at corresponding elongation per metre (inch) of width,  
 $F$  = determined force on the drawn tangent line, N (lbf),  
 $\epsilon_p$  = corresponding elongation, %, with respect to the drawn tangent line and determined force, and  
 $W_s$  = specimen width, m (in.).

10.3.2 *Offset Modulus*—Determine the location and draw a line tangent to the force-elongation curve between the first point of inflection and the proportional limit and through the zero load axis. Measure the force and the corresponding elongation with respect to the load axis. Calculate offset tensile modulus using Eq 5.

$$J_o = (F \times 100) / (\epsilon_p \times W_s) \quad (5)$$

where:

$J_o$  = offset tensile modulus, N (lbf), at corresponding elongation per metre (inch) of width,  
 $F$  = determined force on the drawn tangent line, N (lbf),  
 $\epsilon_p$  = corresponding elongation, %, with respect to the drawn tangent line and determined force, and  
 $W_s$  = specimen width, m (in.).

10.3.3 *Secant Modulus*—Select a force for a specified elongation,  $\epsilon_2$ , usually 10 %, and label the corresponding point on the force-elongation curve as  $P_2$ . Likewise, label a second point,  $P_1$ , at a specified elongation,  $\epsilon_1$ , usually 0 % elongation. Draw a straight line (secant) through both points  $P_1$  and  $P_2$  intersecting the zero load axis. The preferred values are 0 and 10 % elongation, respectively, although other values may be substituted by the design engineer. Calculate secant tensile modulus using Eq 6.

$$J_{sec} = (F \times 100) / (\epsilon_p \times W_s) \quad (6)$$

where:

$J_{sec}$  = secant tensile modulus, N (lbf), between specified elongations per metre (inch) of width,

$F$  = determined force on the constructed line, N (lbf),  
 $\epsilon_p$  = corresponding elongation, %, with respect to the constructed line and determined force, and  
 $W_s$  = specimen width, m (in.).

#### 10.4 Breaking Toughness:

10.4.1 When using the force-elongation curves, draw a line from the point of maximum force of each specimen perpendicular to the elongation axis. Measure the area bounded by the curve, the perpendicular, and the elongation axis by means of an integrator or a planimeter, or cut out the area of the chart under the force-elongation curve, weigh it, and calculate the area under the curve using the weight of the unit area.

10.4.2 When determining the breaking toughness of geomembranes using a manual gage (steel rule or dial) to measure the amount of strain at a given force, record the change in specimen length for at least ten corresponding force intervals. Approximately equal force increments should be used throughout the application of force having the final measurement taken at specimen rupture.

10.4.3 Calculate the breaking toughness or work-to-break per unit surface area for each specimen when using XY recorders using Eq 7, or when using automatic area measuring equipment using Eq 8, or when using manually obtained strain measurements with a steel rule or dial gage using Eq 9:

$$T_u = (A_c \times S \times R) / (W_c \times C \times A_s) \quad (7)$$

$$T_u = (V \times S \times R) / (I_c \times A_s) \quad (8)$$

$$T_u = \int_0^F (pd\Delta L) \quad (9)$$

where:

$T_u$  = breaking toughness,  
 $A_c$  = area under force-elongation curve,  
 $S$  = full scale force range,  
 $R$  = testing speed rate,  
 $W_c$  = recording chart width,  
 $C$  = recording chart speed,  
 $A_s$  = area of test specimen within the gage length,  
 $V$  = integrator reading,  
 $I_c$  = integrator constant,  
 $F_f$  = observed breaking force,  
 $\Delta L$  = unit change in length from a zero force to the corresponding measured force,  
 $p$  = unit stress per area of test specimen within the gage length, and  
 $0$  = zero force.

10.5 *Average Values*—Calculate the average values for tensile strength, elongation, initial tangent modulus, secant modulus, and breaking toughness to three significant figures.

10.6 *Standard Deviation (Estimated)*— Calculate the stan-

ard deviation using Eq 10 and report the value to two significant figures:

$$s = \sqrt{\Sigma(x - \bar{x})^2 / (n - 1)} \quad (10)$$

where:

$s$  = estimated standard deviation,  
 $x$  = value of a single observation,  
 $n$  = number of observations, and  
 $\bar{x}$  = arithmetic mean of the set of observations.

## 11. Report

11.1 Report that the specimens were tested as directed in this test method, or any deviations from this test method. Describe all materials or products sampled and the method of sampling each material.

11.2 Report all of the following applicable items for both machine direction and cross machine direction of all materials tested:

11.2.1 Average force at failure in N/m (lbf/in.) of width as tensile strength,

11.2.2 Average elongation at failure in percent, and the method of measuring elongation,

11.2.3 Average initial tangent or secant modulus in N/m (lbf/in.) of width. For secant modulus, state that portion of the force-elongation curve used to determine the modulus, that is, 0 to 10 % elongation reported as 10 % secant modulus. Other portions of the force-elongation curve can be reported as appropriate for the design requirements,

11.2.4 The standard deviation or the coefficient of variation of the test results,

11.2.5 Thickness and width of specimens,

11.2.6 Number of specimens tested,

11.2.7 Make and model of the testing machine,

11.2.8 Grip separation (initial),

11.2.9 Crosshead speed (rate of separation),

11.2.10 Gage length (if different from grip separation),

11.2.11 Type, size, and facing of grips, and description of any changes made to the grips,

11.2.12 Conditioning of specimens, including details of temperature, relative humidity, and conditioning time, and

11.2.13 Anomalous behavior, such as tear failure or failure at the grip.

## 12. Precision and Bias

12.1 *Precision*—The precision of this test method is being established.

12.2 *Bias*—This test method has no bias since the values of those properties can be defined only in terms of a test method.

APPENDIXES

(Nonmandatory Information)

X1. GEOMEMBRANE FAILURE

X1.1 During tensile testing, geomembrane failure normally occurs in one of the three patterns shown in Fig. X1.1.

X1.1.1 Geomembranes which are reinforced using woven textile fabrics (curve 1) exhibit failure as a marked decrease in

tensile force per unit elongation when the reinforcing material ruptures. The reinforcing material may exhibit sudden rupture as a unit, or may exhibit a stair-stepping rupture as individual fibers fail, based upon the rate of loading and the specific reinforcing material. As shown in Fig. X1.1, the geomembrane material may continue to elongate following rupture of the reinforcing material; however, the geomembrane is no longer intact, and the force-elongation relationship has been irreversibly altered.

X1.1.2 Nonreinforced geomembranes which exhibit a yield point (curve 2) exhibit failure as a maximum in the force-elongation curve. The geomembrane continues to elongate at a reduced force per unit elongation until the geomembrane eventually ruptures. Rupture force may be either higher or lower than yield force depending upon the characteristics of the polymer from which the geomembrane is manufactured. However, the force-elongation relationship has been irreversibly altered at the yield point.

X1.1.3 Nonreinforced geomembranes which do not exhibit a yield point (curve 3) exhibit failure as rupture of the geomembrane.

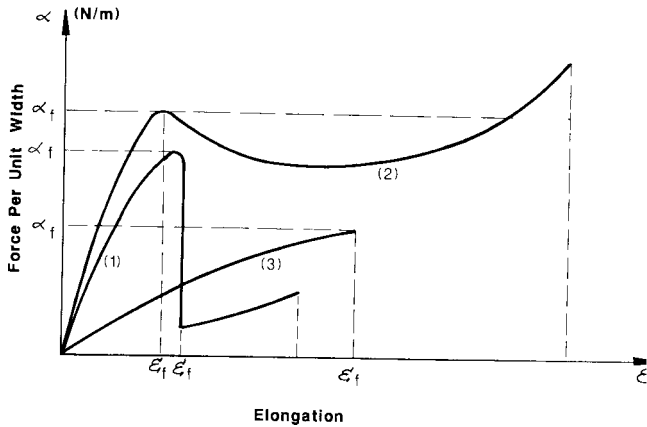

FIG. X1.1 Geomembrane Failure Patterns

X2. CLAMPING SYSTEMS

X2.1 Fig. X2.1, Fig. X2.2, Fig. X2.3, and Fig. X2.4 show the details of clamping systems which have been successfully used in wide strip tensile testing of geotextiles. These clamping systems provide a starting point from which users can adapt clamps for their individual needs. Users must bear in mind that

clamp damage can cause premature failure in geomembranes, geosynthetics, and other materials. It is of paramount importance to design or modify clamps which will not alter the test results by damaging the material undergoing testing.

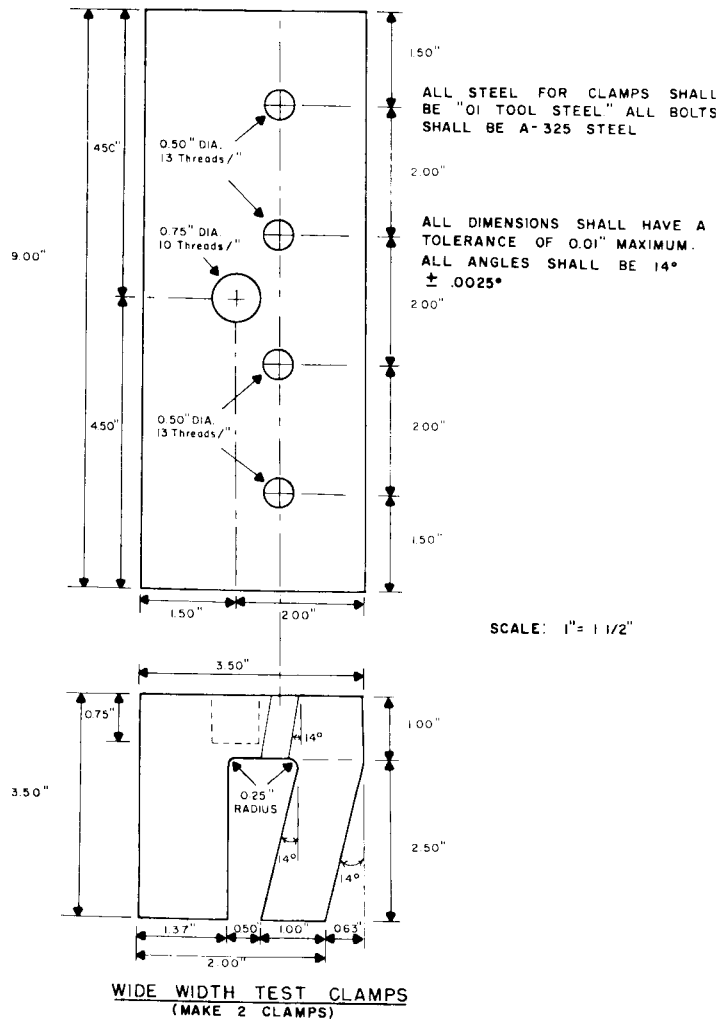

FIG. X2.1 Wide Width Test Clamps

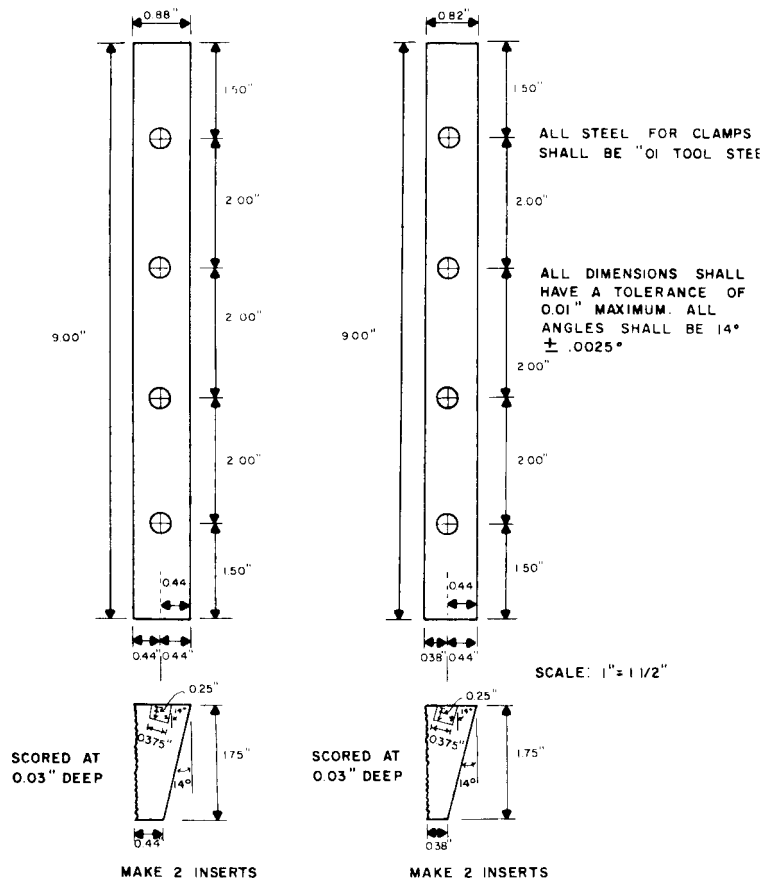

FIG. X2.2 Inserts for Wide Width Clamps

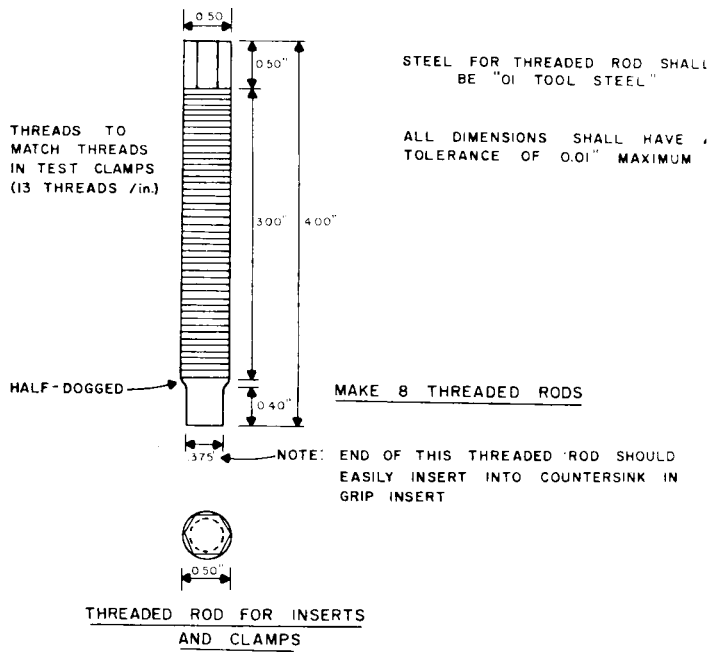

FIG. X2.3 End View of Composite of Clamp, Insert, and Threaded Rod

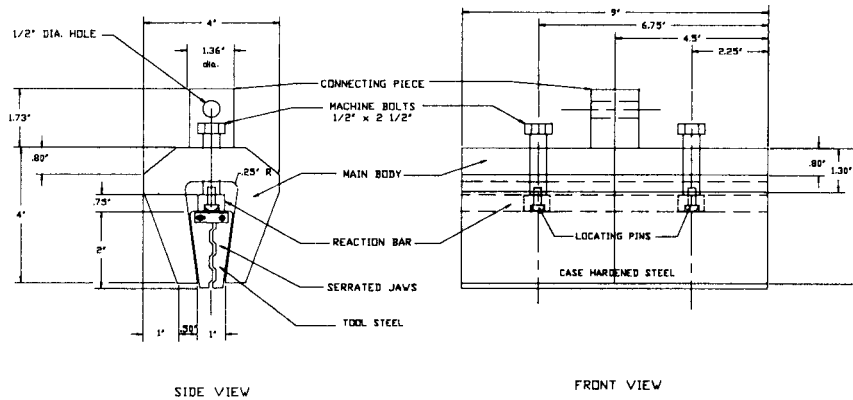

FIG. X2.4 Sanders Clamp

### X3. EXTENSOMETERS

X3.1 Three types of extensometers have been successfully used in testing geosynthetics.

X3.1.1 Direct reading extensometers are mounted directly on the geosynthetic. Typically these extensometers consist of LVDT units which read elongation directly as the material extends. These units place an additional force (weight) on the material undergoing testing, and may result in alteration of the force-elongation results. The user should bear the absolute value of the additional force in mind, and consciously deter-

mine that this additional force is or is not significant for the material being tested.

X3.1.2 Semi-remote reading extensometers use clamps which are mounted directly on the geosynthetic and LVDT units which are mounted independently of the geosynthetic. Wires, pulley systems or other physical devices connect the clamps to LVDT units.

X3.1.3 Remote extensometers use clamps or markers which are mounted directly on the geosynthetic and sensing units

which are mounted independently both of the geosynthetic and the clamps or markers. These sensing units use electromagnetic radiation, such as light, to sense the distance between markers.

X3.2 Users must bear in mind that clamps, markers, or other physical attachments can damage materials undergoing testing. This damage can cause premature failure in geomembranes, geosynthetics, and other materials. It is of paramount importance to design and use clamps, markers, or other attachments in a manner which will not alter the test results by damaging the material undergoing testing.

X3.3 Grip separation has been used for measuring elongation during tensile testing of geomembranes, geosynthetics, and other materials. Grip separation measurements may not produce reliable results for materials which exhibit yield, including polyethylene geomembranes. These materials may yield near the grip and the yielding process may rob material from within the grip, producing an erroneous test result for elongation. The user must consider this phenomenon in selecting grip separation as a means of measuring elongation in materials which exhibit yield.

*The American Society for Testing and Materials takes no position respecting the validity of any patent rights asserted in connection with any item mentioned in this standard. Users of this standard are expressly advised that determination of the validity of any such patent rights, and the risk of infringement of such rights, are entirely their own responsibility.*

*This standard is subject to revision at any time by the responsible technical committee and must be reviewed every five years and if not revised, either reapproved or withdrawn. Your comments are invited either for revision of this standard or for additional standards and should be addressed to ASTM Headquarters. Your comments will receive careful consideration at a meeting of the responsible technical committee, which you may attend. If you feel that your comments have not received a fair hearing you should make your views known to the ASTM Committee on Standards, 100 Barr Harbor Drive, West Conshohocken, PA 19428.*