



Designation: D 5397 – 99

Standard Test Method for Evaluation of Stress Crack Resistance of Polyolefin Geomembranes Using Notched Constant Tensile Load Test¹

This standard is issued under the fixed designation D 5397; the number immediately following the designation indicates the year of original adoption or, in the case of revision, the year of last revision. A number in parentheses indicates the year of last reapproval. A superscript epsilon (ϵ) indicates an editorial change since the last revision or reapproval.

1. Scope

1.1 This test method is used to develop test data from which the susceptibility of polyolefin geomembrane sheet material to stress cracking under a constant tensile load condition and an accelerated environmental condition can be evaluated.

1.2 This test method measures the failure time associated with a given test specimen at a specified tensile load level. Results from a series of such tests utilizing a range of load levels can be used to construct a stress-time plot on a log-log axis.

1.3 The values stated in SI units are to be regarded as the standard. The inch-pound units given in parentheses are provided for information only.

1.4 *This standard does not purport to address all of the safety concerns, if any, associated with its use. It is the responsibility of the user of this standard to establish appropriate safety and health practices and determine the applicability of regulatory limitations prior to use.*

2. Referenced Documents

2.1 ASTM Standards:

D 638 Test Method for Tensile Properties of Plastics²

D 883 Terminology Relating to Plastics²

D 4354 Practice for Sampling of Geosynthetics for Testing³

D 4491 Test Methods for Water Permeability of Geotextiles by Permittivity³

D 4833 Test Method for Index Puncture Resistance of Geotextiles, Geomembranes, and Related Products³

3. Terminology

3.1 Definitions:

3.1.1 *geomembrane, n*—very low permeability synthetic membrane liners or barriers used with any geotechnical engi-

neering related material so as to control fluid migration in a man-made project, structure, or system (see Test Method D 4833).

3.1.2 *stress crack, n*—an external or internal crack in a plastic caused by tensile stresses less than its short-time mechanical strength (see Definitions D 883).

3.1.2.1 *Discussion*—The development of such cracks is frequently accelerated by the environment to which the plastic is exposed. The stresses that cause cracking may be present internally or externally or may be combinations of these stresses.

4. Summary of Test Method

4.1 This test method consists of subjecting a dumbbell shaped notched test specimen from a polyolefin sheet to a constant tensile load in the presence of a surface-active agent and at an elevated temperature. The time to failure of the test specimen is recorded. The results of a series of such tests conducted at different stress levels are presented by plotting stress level against failure time for each stress level on a log-log axis.

5. Significance and Use

5.1 This test method does not purport to interpret the resulting response curve. Such interpretation is left to the parties involved in the commissioning and reporting of the test results.

5.2 This test method is intended as an index test and may be used for grading polyolefin geomembrane sheets in regard to their stress cracking sensitivity.

5.2.1 Conditions that can affect stress cracking include: level of loading, test temperature and environment, microstructure, polymer additive package, processing history, and thermal history.

6. Apparatus

6.1 *Blanking Die*—A die suitable for cutting test specimens to the dimensions and tolerances shown in Fig. 1.

¹ This test method is under the jurisdiction of ASTM Committee D-35 on Geosynthetics and is the direct responsibility of Subcommittee D35.02 on Endurance Properties.

Current edition approved Dec. 10, 1999. Published March 2000. Originally published as D 5397 – 93. Last previous edition D 5397 – 95.

² *Annual Book of ASTM Standards*, Vol 08.01.

³ *Annual Book of ASTM Standards*, Vol 04.13.

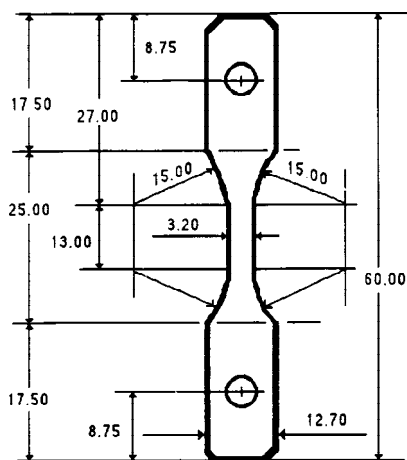

NOTE 1—Dimensioned in millimetres to an accuracy of 0.02 mm.
FIG. 1 Dimensions of Test Method D 1822 Type "L" Test Specimens

NOTE 1—The length of the specimen can be changed to suit the design of the test apparatus. However, there should be a constant neck section with length at least 13 mm (0.5 in.) long. The width should be 3.20 mm (0.125 in.).

6.2 Notching Device—A device or machine that can produce a consistent notch depth.⁴

NOTE 2—An evaluation of the notching technique can be performed by quenching a notched specimen in liquid nitrogen and then fracturing it. The notch depth can readily be measured by examining the fracture surface under a reflected light microscope

6.3 Stress Cracking Apparatus—Equipment suitable for subjecting test specimens to a tensile stress of up to 13.8 MPa (2000 lb/in.²). The specimens shall be maintained at a constant temperature of 50 ± 1°C (122 ± 2°F) while being totally immersed in a surface-active agent. The solution should be constantly agitated to provide a uniform concentration throughout the bath.

NOTE 3—The apparatus⁵ shown in Fig. 2 is one type that has been used and is capable of testing up to 20 specimens at a time. This equipment uses a lever system with a mechanical advantage (MA) of three to impose the desired loading on each specimen. The surface-active agent in which the specimens are immersed is contained in an open stainless steel tank. A submersion heater and controller are used to maintain the test temperature. A pump keeps the liquid in a constant state of agitation. A timing clock for each test specimen is also provided to record automatically the failure time of the test specimens to the nearest 0.1 h.

NOTE 4—If "on/off" switches are used to control the timing clock, the switch must be sensitive enough to be turned off under 200 g of the force.

7. Reagent

7.1 The reagent should consist of 10 % surface-active agent with 90 % water. The surface-active agent is Igepal CO-630⁶ that is nonylphenoxy poly(ethyleneoxy)ethanol. The reagent

⁴ Notching equipment is available through REMCO Industrial Machine Co., Manville, NJ 08850.

⁵ This equipment is available through Custom Scientific Instruments Co., Cedar Knolls, NJ 07927, and BT Technology Inc., 613 W. Clinton St., Rushville, IL 62681.

⁶ Igepal CO-630 may be obtained from Rhone-Poulenc, CN 7500, Prospect Plains Road, Cranbury, NJ 08512-7500.

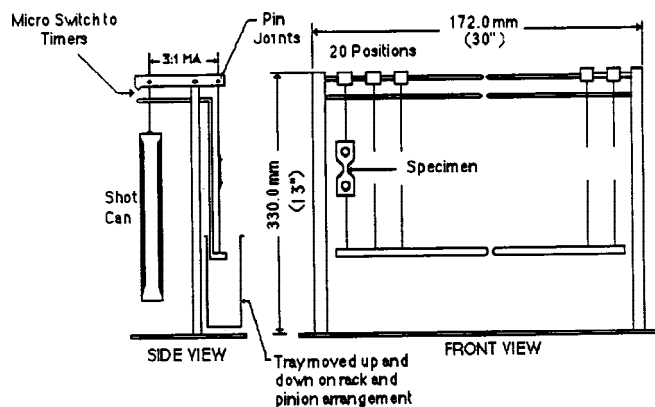

NOTE 1—The number of positions in the test frame is optional.
FIG. 2 Constant Stress Loading Apparatus Consisting of Twenty Specimen Test Positions

should be stored in a closed container. The reagent in the bath should be replaced every two weeks to maintain a constant concentration.

NOTE 5—In case of dispute, the water should be distilled or deionized at the discretion of the parties involved.

NOTE 6—Other incubation solutions may also be used in the test, provided that the parties involved mutually agree to the changes and state the specific details in the final report.

8. Sampling

8.1 Lot Sample—Divide the product into lots and take the lot sample as directed in Practice D 4354.

8.2 Laboratory Sample—As a laboratory sample for acceptance testing, take a full-width swatch approximately 1 m (40 in.) long in the machine direction from each roll in the lot sample. The sample may be taken from the end portion of a roll provided there is no evidence it is distorted or different from other portions of the roll.

8.3 Test Specimens—At least thirty test specimens are cut from each swatch in the laboratory sample. For each set of tests, all specimens must be taken from one direction.

NOTE 7—Quite often the test is required to challenge the weakest direction of the sheet material. If this is the cross machine direction, the test specimens should be cut in this direction. Hence the notch is placed in the machine direction so that the specimens are stressed in the desired cross machine direction.

NOTE 8—It has been found that inserting a grommet or eyelet in the two holes at the end tabs of the test specimen helps to reduce the number of "grip failures" or failures occurring outside of the neck section of the specimen.

9. Procedure

9.1 Measure the thickness of each individual test specimen at its minimum cross section to the nearest 0.013 mm (0.001 in.). The variation in thickness should not be greater than ± 0.026 mm (± 0.002 in.) of the nominal thickness of the geomembrane.

9.2 Cut into each specimen a control imperfection (notch) on one surface as shown in Fig. 3. The depth of the notch should produce a ligament thickness of 80 % of the nominal thickness of the specimen.

ASTM D 5397 – 99

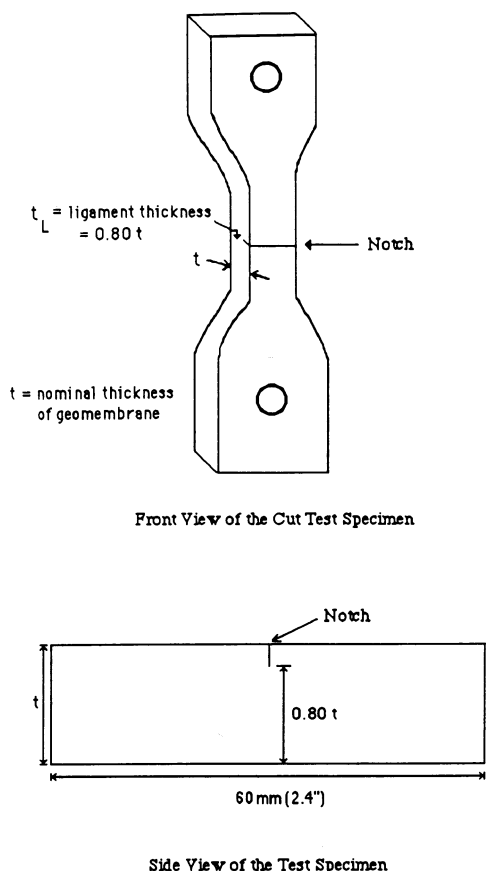

FIG. 3 Front and Side Views of the Notched Test Specimen of NCTL Test

NOTE 9—Using this procedure the actual notch depth will vary in accordance with the actual thickness of the test specimen. For example, a sheet of nominal thickness of 2 mm (80 mil) might have thicknesses ranging from 1.98 to 2.08 mm (78 to 82 mil). To obtain a constant hinge thickness of 1.6 mm (64 mil), the notch depth would vary from 0.36 to 0.46 mm (14 to 18 mil), depending upon the actual thickness of the individual test specimens.

9.3 Inspect the edge of the blade for scratches and burrs under normal vision prior to the cut. No single blade shall be used for notching more than 20 test specimens.

9.4 Test specimens are loaded at various percentages of their room temperature yield stress. The applied stress levels should range from approximately 20 to 65 % at maximum increments of 5 %. Three specimens are tested at each stress level to produce statistically significant results.

NOTE 10—To develop the entire curve in a single direction at the recommended values listed above will require ten increments at three specimens each, or 30 individual tests. If both directions are to be challenged, the entire test will require twice as many test specimens.

9.5 For each set of test, the yield stress of the material should be measured according to Test Method D 638 (Type IV). Five specimens should be tested and the average value is used to calculate the applied force. The test specimens should be cut from the same sample and same direction as stated in 8.3.

9.6 Calculate the tensile force to be applied to each individual specimen from the equation given below:

$$\text{applied force} = (A)(\sigma_y)(w)(t_L)(1/MA) \quad (1)$$

where:

- applied force = force to be applied to achieve a specific percentage of the yield stress, N (lb),
- A = percentage of yield stress to be achieved,
- σ_y = the yield stress of the material at room temperature, N/m²(lb/in.²),
- w = width of the neck of the test specimen (3.20 mm (0.125 in.)),
- t_L = the ligament thickness of the test specimen, that is, recommended to be 80 % of the nominal thickness, mm (in.), and
- MA = mechanical advantage of the test apparatus, that is 3.0 for the apparatus shown in Fig. 2.

9.7 Fill the test bath with reagent, and adjust the temperature to 50 ± 1°C (122 ± 2°F).

NOTE 11—Other temperatures may be used when conducting this test. However, it must be mutually agreed upon by parties involved and the test temperature must be stated in the final report.

9.8 Attach the test specimens to the hooks of the test apparatus.

9.9 Adjust the distance between the lever arm and the switch to a dimension equal to 20 mm (0.80 in.).

9.10 Immerse the test specimens and allow temperature equilibrium to be reached. The minimum time is 30 min.

9.11 Prepare the appropriated weight of lead shot (or other types) required for each individual test specimen according to the calculation in 9.6.

9.12 Load each individual specimen with its respective weight and record the elapsed time to failure to the nearest 0.1 h.

NOTE 12—Other test duration time can be used besides failure time. However, it must be mutually agreed upon by parties involved and the duration of the test must be stated in the final report.

NOTE 13—Expanded polystyrene or other types of insulation can be placed on top of the liquid to minimize the evaporation of water and oxidation of liquid.

NOTE 14—The liquid level in the bath can be maintained by using an automatic water feeder.

9.13 For each of the applied stress levels, calculate the arithmetic mean of the three failure time values and report it as the “average failure time” for that particular applied stress level.

9.14 Calculate the coefficient of variation as follows and report it to two significant figures:

$$\text{coefficient of variation (V)} = (\text{standard deviation/mean}) \times 100 \% \quad (2)$$

The value (V) must be less than 15 % for those with average failure time greater than 10 h. If not, three new specimens should be tested at that specific applied stress level again.

10. Interpretation of Results

10.1 Present the test data in graphic form by plotting the logarithm of percentage yield stress versus the logarithm of the average failure time for each stress level. Three possible types of curves can result, see Fig. 4.

11. Report

11.1 Report the following:

11.1.1 Complete identification of the material tested,

11.1.2 Yield stress used in the test,

11.1.3 Method of conditioning used if different from that specified herein,

11.1.4 Report the average failure time and coefficient of variation values for each of the applied stress levels, and

11.1.5 A plot of the percent yield stress against average failure time on log-log axes.

12. Precision and Bias

12.1 *Precision*—The precision of the procedure in this test method is being established.

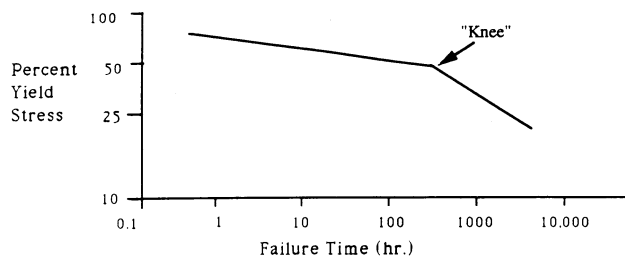

(a) A Bi-Linear (or “Knee”) Response Curve

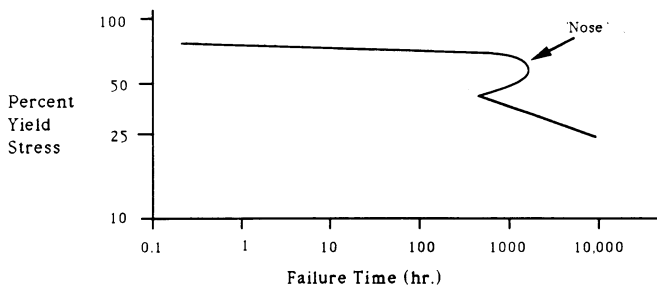

(b) A Overshoot (or “Nose”) Response Curve

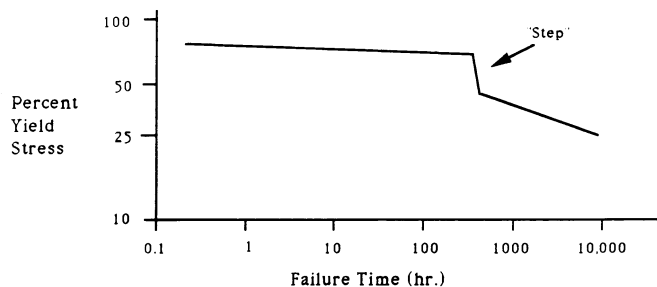

(c) A Tri-Linear (or “Step”) Response Curve

FIG. 4 Possible Response of Curves Resulting from a Complete Notched Constant Tensile Load (NCLT) Test

12.2 *Bias*—The procedure in this test method for measuring the failure time at different applied stress has no bias because the value of the failure time can be defined only in terms of a test method.

13. Keywords

13.1 failure time; geomembrane; notch; polyolefin; yield stress

APPENDIX

(Nonmandatory Information)

X1. PROCEDURE TO PERFORM A SINGLE POINT NOTCHED CONSTANT TENSILE LOAD (SP-NCTL) TEST

X1.1 Sampling:

X1.1.1 *Test Specimens*—Five test specimens are cut from a representative sample of the geomembrane sheet under investigation. All specimens must be cut in the same direction.

NOTE X1.1—Notes 7 and 8 of this test method should also apply.

NOTE X1.2—The procedure is recommended for sheets with thicknesses ranging from 1.0 to 2.5 mm (0.040 to 0.10 in.).

NOTE X1.3—This procedure is not appropriate for testing geomembranes with textured or irregular rough surfaces. The irregular surface makes the determination of the ligament thickness, and subsequent applied stress unreliable.

X1.2 Recommended Procedure:

X1.2.1 The specimen notching procedure should be in accordance with 9.1-9.3.

X1.2.2 All notched test specimens are to be loaded to an equal stress level.

X1.2.2.1 The stress level applied to the test specimens should be either,

a) 30 % of the room temperature yield stress of the sheet under investigation. The yield stress of the sheet should be measured according to Test Method D 638 (Type IV). Five specimens should be tested and the average value is used to calculate the applied force. The tensile test specimen should be cut from the same sample and same direction as stated in X1.1.1.

b) Other stress or force values as mutually agreed to by the parties involved.

X1.2.3 Calculate the applied tensile force from the equation given below:

$$F = (\sigma) \cdot (w) \cdot (t_L) \cdot (1/MA) \quad (X1.1)$$

where:

F = force to be applied to achieve 30 % of the yield stress, N (lb),

σ = the applied stress value determined by either X1.2.2.1 (a) or (b), N/m²(lb/in.²),
 w = width of the neck of the test specimen,
 t_L = the ligament thickness of the notched test specimen, (recommended to be 80 % of the nominal thickness of the sheet), mm (in.), and

MA = mechanical advantage of the test apparatus.

X1.2.4 The incubation conditions for the notched test specimens should be in accordance with 9.7-9.12.

X1.2.5 The duration of the test should be either one of the following:

X1.2.5.1 Tests are run for a predetermined time period—The tests are terminated immediately after a predetermined length of time which is mutually agreed upon by the parties involved.

X1.2.5.2 Tests are taken to failure—The tests continue until all five specimens fail. The arithmetic mean of the five failure times is calculated along with the coefficient of variation.

X1.3 Report

X1.3.1 Complete identification of the sheet material tested including test orientation.

X1.3.2 Room temperature yield stress and percent of yield stress, or other stress/load used in the test.

X1.3.3 Report any changes that are different from the standard herein.

X1.3.4 If the tests are run for a predetermined time period, state the following:

X1.3.4.1 The prescribed time period as set by the parties involved,

X1.3.4.2 If specimen(s) fail before the prescribed time period, report their failure time(s), otherwise state “no failure”.

X1.3.5 If the tests continue until failure, report the average time and coefficient of variation.

ASTM International takes no position respecting the validity of any patent rights asserted in connection with any item mentioned in this standard. Users of this standard are expressly advised that determination of the validity of any such patent rights, and the risk of infringement of such rights, are entirely their own responsibility.

This standard is subject to revision at any time by the responsible technical committee and must be reviewed every five years and if not revised, either reapproved or withdrawn. Your comments are invited either for revision of this standard or for additional standards and should be addressed to ASTM International Headquarters. Your comments will receive careful consideration at a meeting of the responsible technical committee, which you may attend. If you feel that your comments have not received a fair hearing you should make your views known to the ASTM Committee on Standards, at the address shown below.

This standard is copyrighted by ASTM International, 100 Barr Harbor Drive, PO Box C700, West Conshohocken, PA 19428-2959, United States. Individual reprints (single or multiple copies) of this standard may be obtained by contacting ASTM at the above address or at 610-832-9585 (phone), 610-832-9555 (fax), or service@astm.org (e-mail); or through the ASTM website (www.astm.org).