



Designation: D 6496 – 9903

## Standard Test Method for Determining Average Bonding Peel Strength Between the Top and Bottom Layers of Needle-Punched Geosynthetic Clay Liners<sup>1</sup>

This standard is issued under the fixed designation D 6496; the number immediately following the designation indicates the year of original adoption or, in the case of revision, the year of last revision. A number in parentheses indicates the year of last reapproval. A superscript epsilon ( $\epsilon$ ) indicates an editorial change since the last revision or reapproval.

### 1. Scope

1.1 This test method covers the laboratory determination of the average bonding strength between the top and bottom layers of a sample of a geosynthetic clay liner (GCL).

1.2 The values in SI units are to be regarded as the standard. The values in pound units are in parentheses for information.

1.3 *This standard does not purport to address all of the safety concerns, if any, associated with its use. It is the responsibility of the user of this standard to establish appropriate safety and health practices and determine the applicability of regulatory limitations prior to use.*

### 2. Referenced Documents

2.1 *ASTM Standards:*

---

<sup>1</sup> This test method is under the jurisdiction of ASTM Committee D35 on Geosynthetics and is the direct responsibility of Subcommittee D35.04 on Geosynthetic Clay Liners.

Current edition approved ~~Dec~~ March 10, 1999; 2003. Published March 2000<sup>3</sup>. Originally approved in 1999. Last previous edition approved in 1999 as D 6496-99.

- D 76 Specification for Tensile Testing Machines for Textiles<sup>2</sup>
- D 123 Definitions of Terms Relating to Textiles<sup>2</sup>
- D 2905 Practice for Statements on Number of Specimens for Textiles<sup>2</sup>
- D 4439 Terminology for Geosynthetics<sup>3</sup>
- D 4595 Test Method for Tensile Properties of Geotextiles by Wide-Width Strip Method<sup>3</sup>
- D 6072 Guide for Obtaining Samples of Geosynthetic Clay Liners<sup>3</sup>
- F 904 Comparison of Bond Strength or Ply Adhesion of Similar Laminates made from Flexible Materials<sup>4</sup>

### 3. Terminology

#### 3.1 Definitions:

3.1.1 *geosynthetic, n*—a product manufactured wholly or in part from polymeric material used with soil, rock, earth, or other geotechnical engineering related material as an integral part of a project, structure or system. **D 4439**

3.1.2 *geosynthetic clay liner, n*—a manufactured hydraulic barrier consisting of clay bonded to a layer or layers of geosynthetic material(s). (Currently being balloted under D-35 Committee on Terminology)

### 4. Summary of Test Method

4.1 The top and bottom layers of a geosynthetic clay liner are gripped individually in tensile grips and pulled at a constant rate of extension by a tensile testing machine until the top and bottom layers of the specimen separate. The average bonding peel strength of the test specimen can be calculated from machine scales, dials, recording charts, or an interface computer.

### 5. Significance and Use

5.1 The bonding strength test for the top and bottom layers of the geosynthetic clay liner is intended to be an index test. It is anticipated that the results of the test will be used to evaluate the quality of the bonding process.

### 6. Apparatus

6.1 *Tensile Testing Machine*—A constant rate of extension (CRE) type of testing machine described in Specification D 76 shall be used with a minimum precision measuring capability of 0.1 N/m ( $5.71 \times 10^{-4}$  lbf/in).

6.2 *Clamps*—The clamps shall be a minimum 25 by 100 mm (1 by 4 in.) and with appropriate clamping power to prevent slipping or crushing (damage).

6.3 *Die or Template*, 100 by 200 mm ( $\pm 1$  mm) (4 by 8 in.).

6.4 *Miscellaneous*, knives, razor, spatulas, scoops, quartering cloth, sample splitters, etc, as required.

### 7. Test Specimen

7.1 The sample received at the testing laboratory should be in satisfactory condition and representative of the product manufactured or delivered to a site, or both.

7.2 The size of the die or template for cutting specimens is 100 by 200 mm (4 by 8 in.).

7.3 The loss of clay during the specimen cutting process should have no bearing on the results of the test.

7.4 A minimum of five test specimens should be cut from the laboratory sample such that they are representative of the entire roll width. All specimens should be parallel to the machine direction.

### 8. Conditioning

8.1 The test specimen shall be tested as received.

### 9. Procedure

9.1 *Obtain Specimens*— Using the die, or template and razor, and other necessary apparatus, carefully cut from the laboratory sample five test specimens. The five specimens should be randomly selected from locations on the sample, but should be distributed across the sample. All specimens should be cut parallel to the machine direction. Using a knife or razor, separate the top and bottom layer of the GCL for the first  $50 \pm 3$  mm ( $2 \pm 0.1$  in.).

9.2 *Machine Set-Up Conditions*—Adjust the distance between the clamps at the start of the test to  $50 \pm 3$  mm ( $2 \pm 0.1$  in.). Set the CRE at 300 mm/min. (12 in./min.).

9.3 *Insertion of Specimen in Clamps*—Mount the specimen centrally in the clamps. The specimen must be visually observed above the clamp. The specimen length in the machine direction must be parallel to the direction of application of force.

9.4 *Measurement of Bonding Peel Strength*—Start the tensile testing machine. This is considered the start of the peel test and represents zero grip separation. Take readings of force and time starting from ~~25~~ 50 mm (~~1~~ 2 in.) of grip separation until ~~125~~ 250

<sup>2</sup> Annual Book of ASTM Standards, Vol 07.01.

<sup>3</sup> Annual Book of ASTM Standards, Vol 04.09.

<sup>4</sup> Annual Book of ASTM Standards, Vol 15.09.

mm (5/16 in.) of grip separation. The average recorded peeling force of the GCL over of 100 200 mm (4 (8 in.) of grip separation is required and will signify a complete test of the specimen. (See Fig. 1).

NOTE 1—If significant elongation of the geotextile continues after 50 mm (2 in.) additional grip peeling of the GCL, the recording interval should be adjusted. The recording interval should correspond to 100 200 mm (4 (8 in.) of grip separation during the peeling of the GCL.

9.4.1 Readings of force and time shall be taken at a minimum rate of 20 readings per second.

9.4.2 If a specimen slips in the jaws, or if for any reason attributable to faulty operation the results falls significantly below the average for the set of specimens, discard the results and test another specimen. Continue until the required number of readings have been taken.

**10. Calculation**

10.1 *Bonding Peel Strength*—Calculate the bond strength of individual specimens; that is, the average force to cause a specimen to separate completely as read directly from the test instrument expressed in N/m (lbf/in.) N (lbf.) of width, using the following equation:

$$\alpha_f = F_{avg}/W_S \tag{1}$$

where:

$\alpha_f$  = bonding peel strength, N/m (lbf/in.) of width,

$F_{avg}$  = observed average force over a grip separation of 25 50 mm (1 (2 in.) to 1250 (5 250 (10 in.), N (lbf), and

$W_S$  = specified specimen width, m (in.).

10.2 *Average Bonding Peel Strength* —Average the calculated bonding peel strength of each specimen:

$$\alpha_{avg} = (\alpha_{f1} + \alpha_{f2} + \dots + \alpha_{f5})/5 \tag{2}$$

where:

$\alpha_{fn}$  = calculated average bond strength for specimen, N/m (lbf/in.) and

$\alpha_{avg}$  = average bond strength of the GCL, N/m (lbf/in.)

**11. Report**

11.1 Report the following information on bonding peel strength of GCL's:

11.1.1 All specimen values and average bonding peel strength/unit width to the nearest 0.1 N/m ( $5.71 \times 10^{-4}$  lbf/in),

11.1.2 If requested, the standard deviation, coefficient of variation, or both,

11.1.3 Sample identification (for example, sample no., roll no., or other traceable identifier),

11.1.4 Type of GCL tested, method used for cutting specimens, sample size, specimen size and shape, number of test specimens used;

11.1.5 Make and model of testing machine;

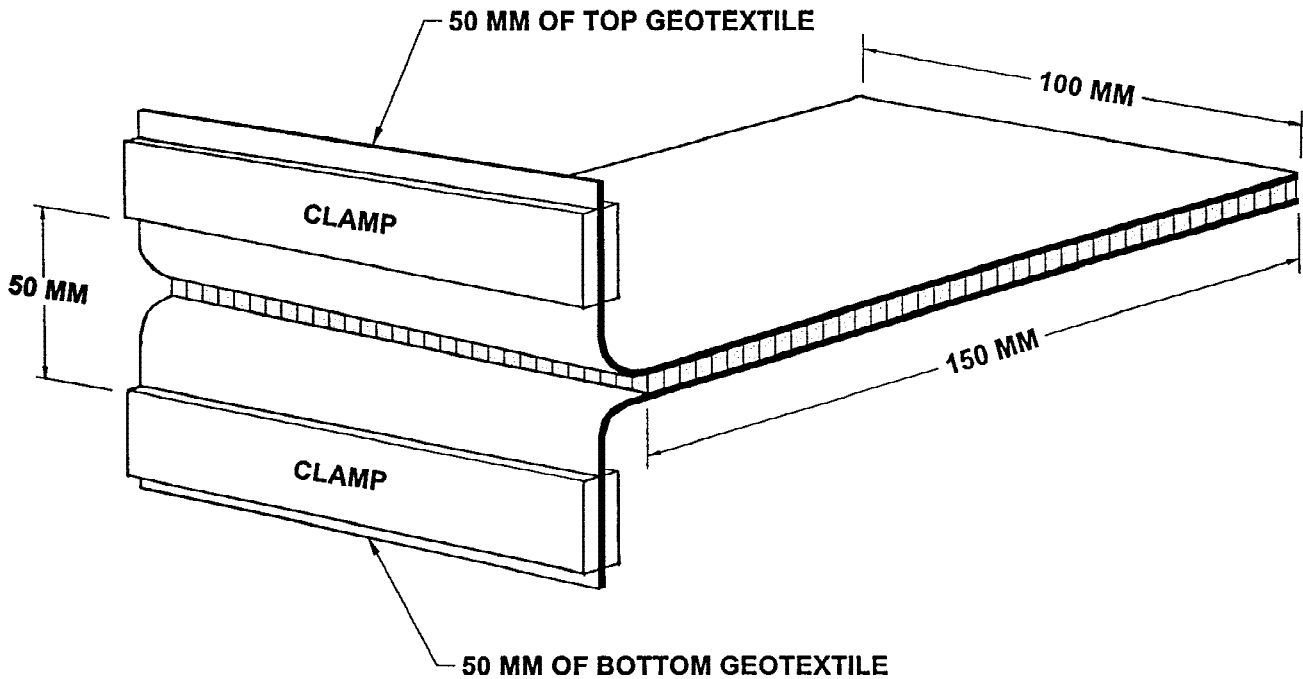

**FIG. 1 Measurement of Bonding Peel Strength**

~~11.1.6~~ Size of jaw of faces used,

~~11.1.7~~ Full tested,

11.1.5 Full scale force range used for testing,

11.1.86 A statement of any departure from the suggested testing procedures so that the results can be evaluated and used,

11.1.97 Note any cause or need for testing additional specimens due to rupture of the geotextile(s) during test, damage to specimen from the grips, etc.,

11.2 Identification of testing agency, person performing the test, date of test and client or project identification, and

~~11.3~~ Verification that the separation of the geotextiles occurred and not due to failure of the geotextile.

## 12. Precision and Bias

12.1 *Precision*—The precision of the procedure in this test method for measuring the bonding strength of the top and bottom layers of a geosynthetic clay liner is being determined.

12.2 *Bias*—The procedure in this test method for measuring the bonding strength of the top and bottom layers of a geosynthetic clay liner has no bias because the value of the bonding strength of a geosynthetic clay liner is defined only in the terms of this test method.

## 13. Keywords

13.1 clay; bonding strength; geosynthetic; geosynthetic clay liner

*ASTM International takes no position respecting the validity of any patent rights asserted in connection with any item mentioned in this standard. Users of this standard are expressly advised that determination of the validity of any such patent rights, and the risk of infringement of such rights, are entirely their own responsibility.*

*This standard is subject to revision at any time by the responsible technical committee and must be reviewed every five years and if not revised, either reapproved or withdrawn. Your comments are invited either for revision of this standard or for additional standards and should be addressed to ASTM International Headquarters. Your comments will receive careful consideration at a meeting of the responsible technical committee, which you may attend. If you feel that your comments have not received a fair hearing you should make your views known to the ASTM Committee on Standards, at the address shown below.*

*This standard is copyrighted by ASTM International, 100 Barr Harbor Drive, PO Box C700, West Conshohocken, PA 19428-2959, United States. Individual reprints (single or multiple copies) of this standard may be obtained by contacting ASTM at the above address or at 610-832-9585 (phone), 610-832-9555 (fax), or service@astm.org (e-mail); or through the ASTM website (www.astm.org).*