

This document is not an ASTM standard and is intended only to provide the user of an ASTM standard an indication of what changes have been made to the previous version. Because it may not be technically possible to adequately depict all changes accurately, ASTM recommends that users consult prior editions as appropriate. In all cases only the current version of the standard as published by ASTM is to be considered the official document.



Designation: D 2061 – 93 (Reapproved 1998)



Designation: D 2061 – 03

Standard Test Methods for Strength Tests for Zippers¹

This standard is issued under the fixed designation D 2061; the number immediately following the designation indicates the year of original adoption or, in the case of revision, the year of last revision. A number in parentheses indicates the year of last reapproval. A superscript epsilon (ε) indicates an editorial change since the last revision or reapproval.

¹ These test methods are under the jurisdiction of ASTM Committee D-13 on Textiles and are the direct responsibility of Subcommittee D13.54 on Subassemblies and were developed in cooperation with the American Fastener and Closure Assn.

Current edition approved June 15, 1993; Dec. 1, 2003. Published August 1993; December 2003. Originally published as D 2061—61 T; approved in 1961. Last previous edition approved in 1998 as D 2061 – 93 (19987).

1. Scope

1.1 These test methods cover the determination of the strengths for zipper and zipper parts. All methods are not suitable for use with all kinds of zipper. The restrictions, if any, are indicated in the scope for each individual test method. The test methods appear as follows:

	Sections
Holding Strengths of Separable Units	25-32
Holding Strength of Slider Lock	82-90
Holding Strength of Stops	17-24
Resistance to Angular Pull-Off of Slider Pull	72-81
Resistance to Cushioned Compression of Sliders	33-42
Resistance to Pull-Off of Slider Pull	62-71
Resistance to Twist of Pull and Slider	52-61
Slider Deflection and Recovery	43-51
Strength of Chains and Elements	9-16

1.2 The values stated in SI units are to be regarded as the standard.

1.3 *This standard does not purport to address all of the safety concerns, if any, associated with its use. It is the responsibility of the user of this standard to establish appropriate safety and health practices and determine the applicability of regulatory limitations prior to use.*

2. Referenced Documents

2.1 ASTM Standards:²

- D 76 Specification for Tensile Testing Machines for Textiles
- D 123 Terminology Relating to Textiles
- D 1776 Practice for Conditioning Textiles for Testing
- D 2050 Terminology Relating to Zippers
- D 2051 Test Method for Durability of Finish of Zippers to Laundering
- D 2052 Test Method for Colorfastness of Zippers to Drycleaning
- D 2053 Test Method for Colorfastness of Zippers to Light
- D 2054 Test Method for Colorfastness of Zipper Tapes to Crocking
- D 2057 Test Method for Colorfastness of Zippers to Laundering
- D 2058 Test Method for Durability of Finish of Zippers to Drycleaning
- D 2059 Test Method for Resistance of Zippers to Salt Spray (Fog)
- D 2060 Test Methods for Measuring Zipper Dimensions
- D 2062 Test Methods for Operability of Zippers

2.2 U. S. Government Standard:

- MIL-105D Sampling Procedures and Tables for Inspection by Attributes³

3. Terminology

3.1 Definitions:

² For referenced ASTM standards, visit the ASTM web site, www.astm.org, or contact ASTM Customer Service at service@astm.org. For Annual Book of ASTM Standards, Vol 07-01, volume information, refer to the standard's Document Summary page on the ASTM web site.

³ Available from Standardization Documents Order Desk, Bldg. 4 Section D, 700 Robbins Ave., Philadelphia, PA 19111-5094, Attn: NPODS.

3.1.1 For definitions of zipper terms relating to zippers used in these test methods, this standard, refer to Terminology D 2050. For definitions of other textile terminology used in this standard, refer to Terminology D 123.

4. Significance and Use

4.1 The usefulness of a zipper in service can be evaluated by these tests. No one test determines the suitability of a zipper for a specific end use. Since the tests are inter-related more than one may be needed for a complete evaluation.

4.2 These methods are considered satisfactory for acceptance testing of commercial shipments because the methods have been used extensively in the trade for this purpose, and because estimates of current between-laboratory precision are acceptable in most cases.

~~4.2.1 In case of a dispute arising from~~

~~4.2.1 If there are differences of practical significance between reported test results when using Test Methods D 2061 for acceptance testing of commercial shipments, the purchaser and the supplier should conduct two laboratories (or more), comparative test should be performed to determine if there is a statistical bias between their laboratories. Competent them, using competent statistical assistance is recommended for the investigation of bias. assistance. As a minimum, the two parties should take a group of test specimens samples should be used that are as homogeneous as possible and possible, that are drawn from a lot of the material of from which the type in question. The disparate test specimens should then be results were obtained, and that are randomly assigned in equal numbers to each laboratory for testing. Other materials with established test values may be used for this purpose. The average test results from the two laboratories should be compared using Student's *t*-test a statistical test for unpaired data and an acceptable data, at a probability level chosen by prior to the two parties before the testing is begun. series. If a bias is found, either its cause must be found and corrected, or the purchaser and the supplier must agree to interpret future test results must be adjusted in the light consideration of the known bias.~~

4.3 The method(s) in the standard along with those in Test Methods D 2051, D 2052, D 2053, D 2054, D 2057, D 2058, D 2059, D 2060, and D 2062 are a collection of proven test methods. They can be used as aids in the evaluation of zippers without the need for a thorough knowledge of zippers. The enumerated test methods do not provide for the evaluation of all zipper properties. Besides those properties measured by means of the enumerated test methods there are other properties that may be important for the satisfactory performance of a zipper. Test methods for measuring those properties have not been published either because no practical methods have yet been developed or because a valid evaluation of the information resulting from existing unpublished methods requires an intimate and thorough knowledge of zippers.

5. Sampling

5.1 *Lot Sample*—As a lot sample for acceptance testing, take at random the number of individual containers from each shipping carton as directed in an applicable material specification or other agreement between the purchaser and the supplier. Consider individual containers from each shipping carton to be the primary sampling units.

NOTE 1—An adequate specification or other agreement between the purchaser and supplier requires taking into account the variability between shipping cartons and between zippers in a container to provide a sampling plan with a meaningful producer's risk, consumer's risk, acceptable quality level, and limiting quality level.

5.2 *Laboratory Sample and Test Specimens*—As a laboratory sample for acceptance testing, take the number of zippers specified in Section 6 at random from each container in the lot sample. Consider the zippers as both the laboratory sample and the test specimens.

6. Number of Specimens

6.1 *Variables*—Take a number of zippers per individual container from each shipping carton such that the user may expect at the 90 % probability level that the test result for an individual container is no more than 10 % of the average, above or below the true average for the individual container. Determine the number of zippers per individual container as follows:

6.1.1 *Reliable Estimate of v* —When there is a reliable estimate of v based upon extensive past records for similar materials tested in the user's laboratory as directed in the method, calculate n using Eq 1.

$$n = t^2 \times v^2/A^2 = 0.0270 v^2 \quad (1)$$

where:

n = number of specimens (rounded upward to a whole number),

v = reliable estimate of the coefficient of variation of individual observations in the user's laboratory under conditions of single-operation precision,

t = 1.645, the value of Student's t for infinite degrees of freedom, two-sided limits and a 90 % probability level ($t^2 = 2.706$),

A = 10.0 % of the average, the value of the allowable variation, and

0.0270 = a value calculated from t^2/A^2

6.1.2 *No Reliable Estimate of v* —When there is no reliable estimate of v for the user's laboratory, Eq 1 should not be used directly. Instead, specify the number of specimens shown in Table 1. This number of specimens is calculated using values of v which are somewhat larger values of v than are usually found in practice. When a reliable estimate of v for the user's laboratory

TABLE 1 Specimens Required Under Conditions of Known and Unknown Variability in User's Laboratory Units as Indicated

Property	Allowable Variation Two-Sided	Equation for n , Using a Reliable Estimate of v	No Reliable Estimate of v	
			Number of Specimens	Basis ^A
<i>Strength of chains and elements:</i>				
Chain crosswise strength	10.0	$n = 0.027 \times v^2$	2	$v = 8.45$
Element pull-off	10.0	$n = 0.027 \times v^2$	5	$v = 12.56$
Element slippage, lengthwise	10.0	$n = 0.027 \times v^2$	7	$v = 14.97$
<i>Holding strength of stops:</i>				
Top stop, holding	10.0	$n = 0.027 \times v^2$	17	$v = 24.77$
Bottom stop holding, slider	10.0	$n = 0.027 \times v^2$	22	$v = 28.41$
Bottom stop holding, crosswise	10.0	$n = 0.027 \times v^2$	8	$v = 16.16$
Bottom stop holding, stringer separation	10.0	$n = 0.027 \times v^2$	7	$v = 15.60$
Bridge top stop, stringer separation	10.0	$n = 0.027 \times v^2$	31	$v = 33.75$
<i>Holding strength of separable units:</i>				
Separable pin	10.0	$n = 0.027 \times v^2$	7	$v = 15.46$
Fixed retainer	10.0	$n = 0.027 \times v^2$	8	$v = 16.34$
Separating unit—crosswise	10.0	$n = 0.027 \times v^2$	4	$v = 10.70$
<i>Slider deflection and recovery:</i>				
mouth	10.0	$n = 0.027 \times v^2$	^B	$v = 93.11$
pull	10.0	$n = 0.027 \times v^2$	^B	$v = 48.20$
<i>Resistance to twist of pull and slider:</i>	10.0	$n = 0.027 \times v^2$	^B	$v = 51.4$

^A The values of v in Table 1 are somewhat larger than will be usually found in practice (see 6.1.2).

^B No standard number of specimens is given for these tests since they are quite variable and are not recommended for acceptance testing except where the laboratories of the purchaser and the seller have established their precision and bias, if any.

becomes available, Eq 1 will usually specify fewer than the number of specimens shown in Table 1.

6.2 *Attributes*—For methods for which the test result merely states whether there is conformance to the criteria for success specified in the procedure, take the number of specimens directed in MIL Standard 105D for the level of inspection agreed upon by the purchaser and the seller. The methods to which these instructions apply are as follows:

	Sections
Resistance to Cushioned Compression of Sliders	30-38
Resistance to Pull-Off of Slider Pull	56-64
Resistance to Angular Pull-Off of Slider Pull	65-73
Holding Strength of Slider Lock	74-81

7. Test Specimen

7.1 The test specimen may consist of a completely assembled zipper, length of chain, or a component, as specified in the individual method.

8. Conditioning

8.1 Bring the specimens to moisture equilibrium for testing in the standard atmosphere for testing textiles as directed in Practice D 1776 unless otherwise specified (see 38.1, 48.1, 57.1, and 77.1). Preconditioning is not required for zippers other than those made of nylon.

STRENGTHS OF CHAINS AND ELEMENTS

9. Scope

9.1 These test methods cover the determination of the strengths of zipper chains and elements in tensile tests.

9.2 The element pull-off and element slippage tests apply to separate element zippers only.

10. Summary of Test Method

10.1 *Crosswise Strength*—The ability of a zipper chain to withstand lateral stress is measured by loading to destruction a 25.4-mm (1-in.) section of a specimen in a tensile testing machine equipped with clamps having special jaws.

10.2 *Element Pull-Off*—The gripping strength of a element around the bead is determined by pulling a single element from the bead at right angles to the stringer using a tensile testing machine fitted with a specially designed fixture.

10.3 *Element Slippage*—The ability of a element to resist longitudinal movement along the bead of the tape is determined with a tensile testing machine fitted with a specially designed fixture.

11. Significance and Use

11.1 *Crosswise Strength*—This test method may be used to determine crosswise strength which measures the resistance of a zipper to such failures as tape rupture, unmeshing, or element separation when the zipper is side stressed during use.

11.2 *Element Pull-off*—This test method may be used to determine element strength which measures a element's ability to resist being fractured or pulled from the bead of the tape when the zipper is side stressed during use.

11.3 *Element Slippage*—This test method may be used to determine element attachment security and measures a element’s ability to remain on the tape bead in proper position to adjacent elements so that zipper operation can be maintained.

12. Apparatus

12.1 *Tensile Testing Machine*—A CRE type testing machine conforming to Specification D 76 with a rate-of-traverse of 305 ± 10 mm (12 ± 0.5 in.)/min. If preferred, the use of a CRT tensile testing machine is permitted. There may be no overall correlation between the results obtained with the CRE and CRT machines. Consequently, the two machines cannot be used interchangeably. In case of controversy, the CRE method shall prevail.

12.2 *Jaws*—The back jaws of the clamps on the tensile testing machine shall be at least the same width as the front jaws. The front jaws shall be 25.4 mm (1 in.) wide and have hardened faces with horizontal grooves 1.6 mm ($1/16$ in.) apart, 0.38 mm (0.015 in.) deep, and be of a V-shape with an included angle of 90° .

12.3 *Element Pull-off Fixture*,⁴ designed to grasp the head of the element by two members as shown in Fig. 1. The fixture must be designed to fit the element under test so as to avoid element distortion.

12.4 *Element Slippage Fixture*,⁴ consisting of a flat plate approximately 6 mm ($1/4$ in.) wide and 2 mm ($1/16$ in.) thick which is twisted 90° midway of its length and bent at one end through a 90° angle to give the fixture an “L” shape. The short leg of the “L” shall be slotted so that the two prongs thus formed will clear the bead and slip under a element in order to pull it along the bead as shown in Fig. 2.

13. Test Specimen

13.1 The test specimen shall consist of a completely assembled zipper or a piece of chain at least 127 mm (5 in.) long.

14. Procedure

14.1 *Chain Crosswise Strength*—Secure the tapes of the zipper or chain in the clamps of the tensile testing machine with the edges of the jaws parallel to the chain and approximately 3 mm ($1/8$ in.) from the outer edge of the interlockable elements or the outer edge of the beads if the bead extends beyond the elements. The ends of the front jaws shall be at least 25 mm (1 in.) from the slider, stops or end of the meshed chain. Apply an increasing load until the elements pull off the bead, until the tape separates, or until failure of some other kind occurs. Record the nature of the failure and the breaking load to the nearest 2.2 N (0.5 lbf).

14.2 *Element Pull-Off*—Secure the element pull-off fixture (Fig. 1) in the top clamp of the testing machine. Then adjust the fixture to grasp a single element on a stringer. Secure the stringer in the bottom clamp of the testing machine as described in 14.1. Apply an increasing load until the element is pulled off or other failure occurs. Record the nature of the failure and the load at failure to the nearest 0.4 N (0.1 lbf).

14.3 *Element Slippage, Lengthwise*—Remove an element from the stringer, taking care not to damage the bead. Cut through the bead and the tape under the bead in the center of the place where the element was removed. Cut the tape with a sharp razor

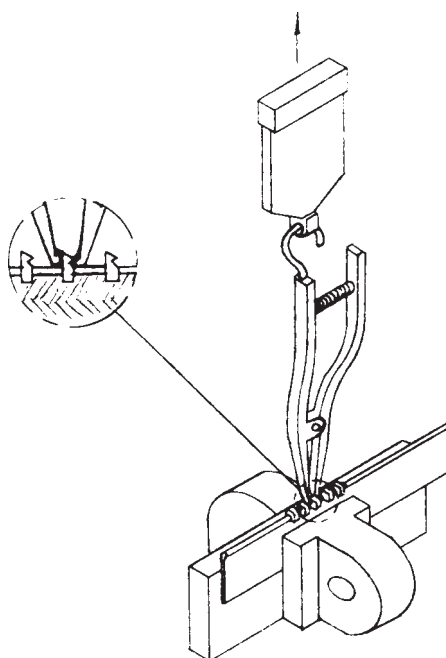

FIG. 1 Fixture for Element Pull-Off Test

⁴ Drawings of the apparatus used in this test method are available from most zipper manufacturers upon request.



FIG. 2 Fixture for Element Slippage Test

blade, single stroke, ignoring blooming if it occurs. The element to be tested is the one just below the element that was removed. Secure the element slippage fixture (Fig. 2) in the top clamp and position the two prongs at the end of the short leg of the “L” in horizontal alignment underneath the element. Secure the stringer in the lower clamp of the testing machine in vertical alignment, positioning the clamps approximately 76 mm (3 in.) below the “L” of the fixture in the upper clamp. Apply an increasing load until the element slips off the end of the cut bead or until other failure occurs. Record the nature of the failure and the load at failure to the nearest 0.4 N (0.1 lbf).

15. Report

15.1 State that the specimens were tested as directed in Sections 9-16 of Test Methods D 2061. Describe the material or product sampled and the method of sampling used.

15.2 Report the following information:

- 15.2.1 The specific property (or properties) evaluated,
- 15.2.2 Number and description of specimens tested, and
- 15.2.3 The observed values and nature of failures of each specimen.

16. Precision and Bias

16.1 *Interlaboratory Test Data*⁵—An interlaboratory test was run in which four laboratories each tested eight specimens, per operator, from each of two materials. Each laboratory used two operators to test each material. All 64 specimens of each material came from the same sample. The components of variance expressed as coefficients of variation, calculated as percentage of the average were:

	Single-Operator Component	Within-Laboratory Component ⁴	Between-Laboratory Component
Chain Crosswise Strength	6.04	0	4.82
Element Pull-Off	8.97	5.56	0
Element Slippage, Lengthwise	10.69	0	0

⁴ All the within laboratory component is attributable to the same operator testing at different times.

16.2 *Precision*—For the components of variance reported in 16.1, two averages of observed values should be considered significantly different at the 90 % probability level if the difference equals or exceeds the critical differences listed in Table 2.

NOTE 2—To convert the values in Table 2 to units of measure, multiply the average of the two specific sets of data being compared by the critical difference expressed as a decimal fraction.

⁵ ASTM Research Report-No. D-13-1018. A copy is available from ASTM Headquarters, 100 Barr Harbor Drive, West Conshohocken, PA 19428.

TABLE 2 Critical Differences for the Properties Listed

	Number of Observations in Each Average	Critical Differences, Percent of Grand Average for the Conditions Noted		
		Single-Operator Precision	Within-Laboratory Precision	Between-Laboratory Precision
Chain Crosswise Strength	1	14.1	14.1	18.0
	3	8.1	8.1	13.8
	5	6.3	6.3	12.9
	10	4.4	4.4	12.1
Element Pull-off	1	20.9	24.5	24.5
	3	12.1	17.7	17.7
	5	9.3	15.9	15.9
	10	6.6	14.5	14.5
Element Slippage, Lengthwise	1	24.9	24.9	24.9
	3	14.4	14.4	14.4
	5	11.1	11.1	11.1
	10	7.9	7.9	7.9

NOTE 3—The tabulated values of the critical differences should be considered to be a general statement particularly with respect to between-laboratory precision. Before a meaningful statement can be made about two specific laboratories, the amount of statistical bias, if any, between them must be established with each comparison being based on recent data obtained on randomized specimens from one sample of the material to be tested.

16.3 *Bias*—No justifiable statement can be made on the bias of the procedures in Test Methods D 2061 for determining the strength of zipper chains and elements, since the true value of the properties cannot be established by an accepted referee method.

HOLDING STRENGTHS OF STOPS

17. Scope

17.1 These test procedures are used to determine the holding strengths of various types of zipper stops.

18. Summary of Test Method

18.1 The ability of stops to perform their intended purpose is determined through the use of five different methods which simulate the important stresses encountered in the end use of zippers.

19. Significance and Use

19.1 *Top Stop Holding*—This test method may be used to determine top stop attachment strength which measures the ability of the top stop to prevent travel of the slider beyond the end of the chain.

19.2 *Bottom Stop Holding, Slider*—This test method may be used to determine bottom stop attachment strength, which measures the ability of the bottom stop to resist failure caused by stress applied longitudinally to the bottom stop through the slider.

19.3 *Bottom Stop Holding, Crosswise*— This test method may be used to determine bottom stop attachment strength, which measures the ability of the bottom stop to hold the two stringers of the chain together when the zipper is side stressed at the bottom stop.

19.4 *Bottom Stop Holding, Stringer Separation*—This test method may be used to determine bottom stop attachment strength, which measures the ability of the bottom stop to resist failure caused by such things as tape bead rupture, element separation from bead or bottom stop displacement due to stress applied through the stringers.

19.5 *Bridge Top Stop, Stringer Separation*—This test method may be used to determine bridge top stop attachment strength, which measures the ability of the bridge top stop to remain in place holding the stringers of a zipper together and limiting slider travel when the stop is stressed through the stringers.

20. Apparatus

20.1 *Testing Machine*, as specified in 12.1.

20.2 *Fixture*,⁴ with a curved end as shown in Fig. 3 to hook the pull of the slider.

21. Test Specimen

21.1 The test specimen shall consist of a completely assembled zipper.

22. Procedure

22.1 In all tests, take care to prevent interference by any locking devices on the slider.

22.2 *Top Stop Holding*—Secure the fixture in the upper clamp of the testing machine and hook the pull of the slider on the fixture (Fig. 3). Position the slider body at the point where normally checked in its free movement by the stop or stops to be tested. Secure the zipper in the lower clamp of the testing machine as illustrated in Fig. 4. The distance between the top edge of the lower clamp and mouth of the slider shall be approximately 76 mm (3 in.). Apply an increasing load until the stop or stops pull off, until

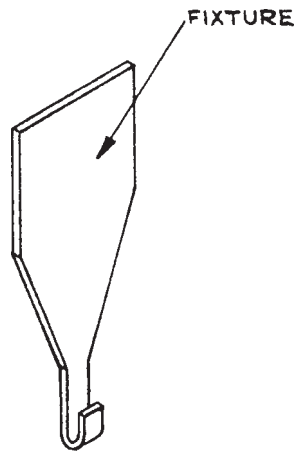

FIG. 3 Fixture for Test for Holding Strength of Top Stop

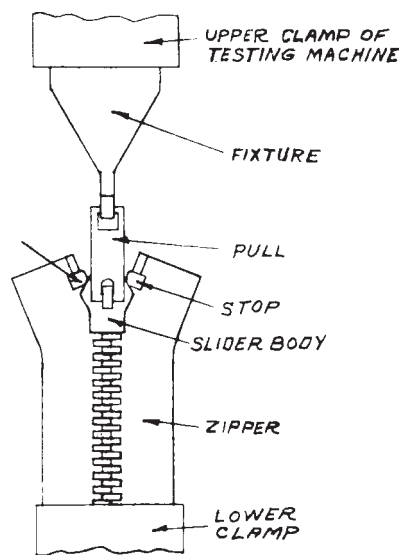

FIG. 4 Top Stop Holding Strength Test

the tape breaks, or until failure of some other kind occurs. Record the nature of the failure and the load at failure to the nearest 2.2 N (0.5 lbf) for values under 222 N (50 lbf) and to the nearest 4.4 N (1 lbf) for values 222 N and over.

22.3 *Bottom Stop Holding, Slider*—Secure the fixture in the upper clamp of the testing machine and hook the pull of the slider on the fixture (Fig. 3). Position the slider at the point where normally checked in its free movement by the bottom stop to be tested. Secure the two stringers in the lower clamp of the testing machine as illustrated in Fig. 5, taking care to equalize the lengths of the two stringers between the clamps. The angle included between the stringers shall be such as to prevent the catching of elements on the flanges or on the diamond. The distance between the top edge of the lower clamp and the nearest surface of the slider body shall be approximately 76 mm (3 in.). Apply an increasing load until the stop pulls off, until the tape breaks, or until failure of some other kind occurs. Record the nature of the failure and the load at failure to the nearest 2.2 N (0.5 lbf) for values under 222 N (50 lbf) and to the nearest 4.4 N (1 lbf) for values 222 N and over.

22.4 *Bottom Stop Holding, Crosswise*—Remove the slider from the zipper. Open the chain by pulling the stringer apart all the way to the bottom stop. From both stringers remove the elements adjacent to but not under the bottom stop for a distance of approximately 13 mm (½ in.). Secure the tapes of the zipper in the clamps of the testing machine with the edges of the jaws parallel to and approximately 3 mm (⅛ in.) from the sides of the bottom stop, which shall be centrally located in the clamps as shown in Fig. 6. Apply the load until the stop pulls apart, until the tape breaks, or until failure of some other kind occurs. Record the nature of the failure and the load at failure to the nearest 2.2 N (0.5 lbf) for values under 222 N (50 lbf) and to the nearest 4.4 N (1 lbf) for values of 222 N and over.

22.5 *Bottom Stop Holding, Stringer Separation*—Position the slider body so that its mouth is against the bottom of the stop to be tested. In the case of the entering type bottom stop, position the slider at the point where normally checked in its free movement. Set the opposing clamps of the testing machine approximately 76 mm (3 in.) apart and secure one of the stringers in the upper clamp and the other in the lower clamp of the tensile testing machine approximately 76 mm apart. Secure the stringers in the upper and lower clamps of the testing machine with the slider body positioned along the axis of the clamps and midway between them

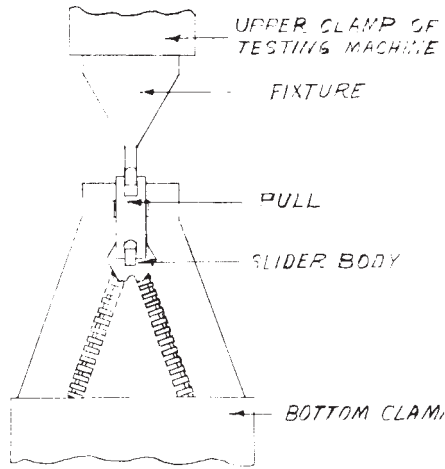

FIG. 5 Bottom Stop Holding Strength Test

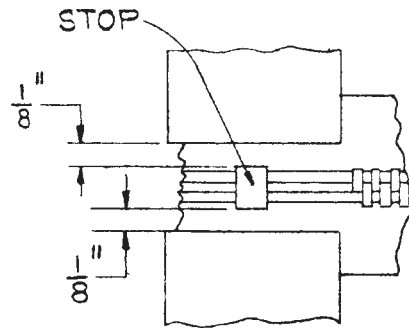

FIG. 6 Bottom Stop Holding, Crosswise Test

as shown in Fig. 7. Apply an increasing load until the stop pulls off, until the tape breaks, or until failure of some other kind occurs. Record the nature of the failure and load at failure to the nearest 2.2 N (0.5 lbf) for values under 222 N (50 lbf) and to the nearest 4.4 N (1 lbf) for values 222 N and over.

22.6 *Bridge Top Stop, Stringer Separation*—With the opposing clamps of the tensile testing machine set approximately 76 mm (3 in.) apart, separate the two stringers and secure them in the opposing clamps of the testing machine. Position the stop along the axis of the clamps and midway between them as shown in Fig. 8. Apply an increasing load until the stop pulls off, until the tape breaks, or until failure of some other kind occurs. Record the nature of the failure and the load at failure to the nearest 2.2 N (0.5 lbf) for values under 222 N (50 lbf) and to the nearest 4.4 N (1 lbf) for values 222 N and over.

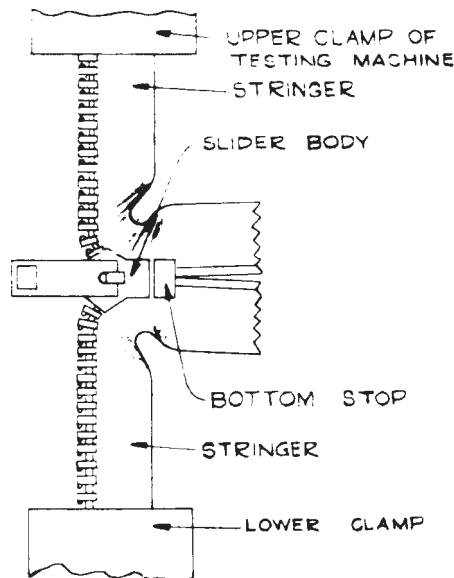

FIG. 7 Bottom Stop Holding, Stringer Separation Test

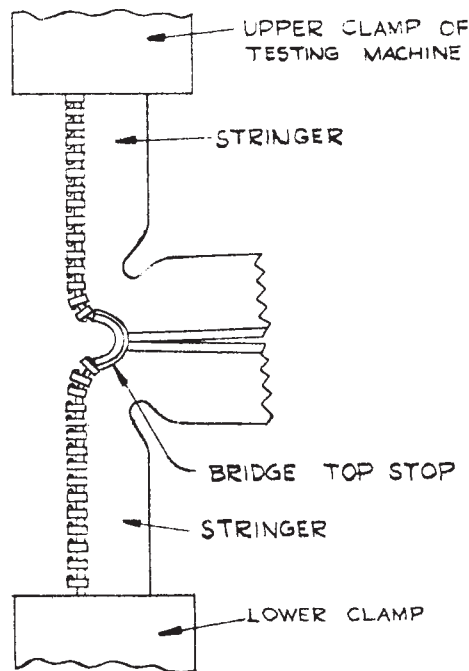

FIG. 8 Bridge Top Stop, Stringer Separation Test

23. Report

23.1 State that the specimens were tested as directed in Sections 17-24 of Test Methods D 2061. Describe the material or product sampled and the method of sampling used.

23.2 Report the following information:

- 23.2.1 The specific property (or properties) evaluated,
- 23.2.2 Number and description of specimens tested, and
- 23.2.3 The observed values and nature of failures of each specimen.

24. Precision and Bias

24.1 *Interlaboratory Test Data*⁵—An interlaboratory test was conducted as described in 16.1. The components of variance expressed as coefficients of variation, percent relative, were calculated to be:

	Single-Operator Component	Within-Laboratory Component ⁴	Between-Laboratory Component
Top Stop Holding	17.35	0	0
Bottom Stop Holding, Slider	20.29	0	12.22
Bottom Stop Holding, Crosswise	11.54	6.09	0
Bottom Stop Holding, Stringer Separation	11.14	0	3.97
Bridge Top Stop, Stringer Separation	24.11	0	0

⁴ All the within laboratory component is attributable to the same operator testing at different times.

24.2 *Precision*—For the components of variance reported in 24.1, two averages of observed values should be considered significantly different at the 90 % probability level if the difference equals or exceeds the critical differences listed in Table 3 (Note 2 and Note 3).

24.3 *Bias*—No justifiable statement can be made on the bias of the procedures in Test Methods D 2061 for determining the holding strengths of stops, since the true value of the properties cannot be established by an accepted referee method.

HOLDING STRENGTHS OF SEPARABLE UNITS

25. Scope

25.1 These test methods cover the determination of the holding strengths of separable units of zipper and parts thereof.

26. Summary of Test Methods

26.1 The strength of attachment of the separable unit components is determined by three test methods that simulate important stresses encountered in end use of zippers.

TABLE 3 Critical Differences for the Properties Listed

	Number of Observations in Each Average	Critical Differences, Percent of Grand Average for the Conditions Noted		
		Single-Operator Precision	Within-Laboratory Precision	Between-Laboratory Precision
Top Stop Holding	1	40.4	40.4	40.4
	3	23.3	23.3	23.3
	5	17.9	17.9	17.9
	10	12.6	12.6	12.6
Bottom Stop Holding, Slider	1	47.2	47.2	55.1
	3	27.2	27.2	39.4
	5	21.0	21.0	35.4
	10	14.8	14.8	32.1
Bottom Stop Holding, Crosswise	1	26.8	30.3	30.3
	3	15.5	21.0	21.0
	5	12.0	18.6	18.6
	10	8.5	16.5	16.5
Bottom Stop Holding, Stringer Separation	1	25.9	25.9	27.5
	3	15.0	15.0	17.6
	5	11.6	11.6	14.8
	10	8.2	8.2	12.4
Bridge Top Stop, Stringer Separation	1	56.1	56.1	56.1
	3	32.3	32.3	32.3
	5	25.1	25.1	25.1
	10	17.1	17.1	17.1

27. Significance and Use

27.1 *Separable Pin, Pull-off*—This test method may be used to determine separable pin attachment strength which measures the ability of the separable pin to resist displacement on the tape bead when a longitudinal force is applied.

27.2 *Fixed Retainer, Pull-off*—This test method may be used to determine fixed retainer attachment strength which measures the ability of the fixed retainer to resist displacement on the tape bead when a longitudinal force is applied.

27.3 *Separating Unit, Crosswise*—This test method may be used to determine meshed separating unit attachment strength which measures the ability of the separating unit to resist failure due to separation from the tape bead, tape fracture or separation of the unit caused by lateral stressing of the zipper at the separating unit.

28. Apparatus

28.1 *Testing Machine*, as specified in 12.1.

28.2 *Separable Pin Fixture*,⁴ as shown in Fig. 9 for holding the separable pin in the pull-off test.

28.3 *Fixed Retainer Fixture*,⁴ as shown in Fig. 10 for holding the fixed retainer in the pull-off test.

29. Test Specimen

29.1 The test specimen shall consist of a completely assembled zipper.

30. Procedure

30.1 *Separable Pin, Pull-Off*—Separate the two stringers and, adjacent to the separable pin, remove one or more elements from the stringer. Secure the separable pin fixture (Fig. 9) in the upper clamp of the testing machine. Then seat the separable pin on the fixture notch as shown in Fig. 9. With a distance of approximately 76 mm (3 in.) between the seated end of the pin and the top of the lower clamp, secure the stringer in the lower clamp. Apply an increasing load until the separable pin pulls off, until the tape breaks, or until failure of some other kind occurs. Record the nature of the failure and the load at failure to the nearest 2.2 N (0.5 lbf) for values under 222 N (50 lbf) and to the nearest 4.4 N (1 lbf) for values 222 N and over.

30.2 *Fixed Retainer, Pull-Off*—Secure the fixture (Fig. 10) in the upper clamp of the testing machine. Separate the two stringers and position the fixed retainer on the upper edges of the slot of the fixture and, with an approximate 76 mm (3 in.) distance between the lower edge of the fixed retainer and the upper edge of the lower clamp, secure the stringer in the lower clamp as shown in Fig. 11. Apply an increasing load until the retainer pulls off, until the tape breaks, or until failure of some other kind occurs. Record the nature of the failure and load at failure to the nearest 2.2 N (0.5 lbf) for values under 222 N (50 lbf) and to the nearest 4.4 N (1 lbf) for values 222 N and over.

30.3 *Separating Unit, Crosswise*—Secure the tapes of the zipper in the clamps of the testing machine as shown in Fig. 12, with the edges of the jaws parallel to, and approximately 3 mm (1/8 in.) from the sides of the separating unit, whether the latter is of a fixed or movable type. Position the separating unit so that the exposed end of the separable pin is aligned with the sides of the front jaws as shown in Fig. 12. Apply the load until the separating unit comes apart, until the tape breaks or until failure of some other kind occurs. Record the nature of the failure and the load at failure to the nearest 2.2 N (0.5 lbf) for values under 222 N (50 lbf) and to the nearest 4.4 N (1 lbf) for values 222 N and over.

31. Report

31.1 State that the specimens were tested as directed in Sections 25-32 of Test Methods D 2061.

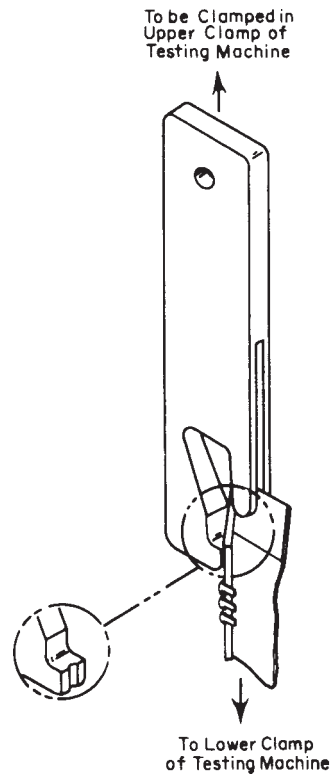

FIG. 9 Fixture for Separable Pin Pull-Off Test

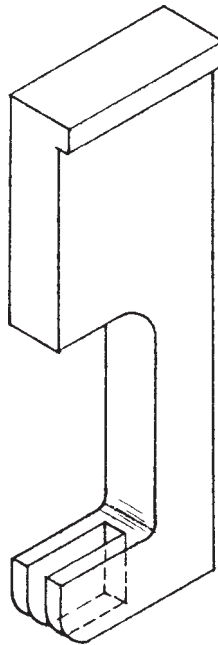

FIG. 10 Fixture for Retainer Pull-Off Test

31.2 Report the following information:

- 31.2.1 The specific property (or properties) evaluated,
- 31.2.2 Number and description of specimens tested, and
- 31.2.3 The observed values and nature of failures of each specimen.

32. Precision and Bias

32.1 *Interlaboratory Test Data*⁵—An interlaboratory test was conducted as described in 16.1. The components of variance expressed as coefficients of variation, percent relative, were calculated to be:

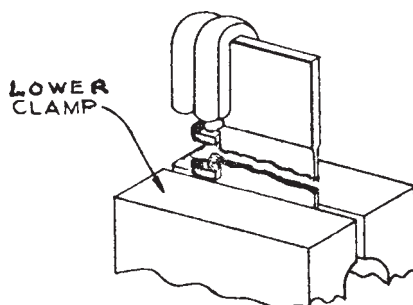

FIG. 11 Fixed Retainer Pull-Off Test

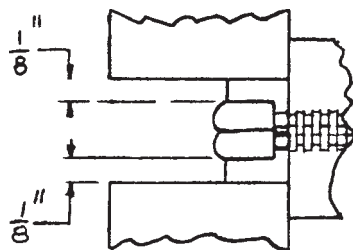

FIG. 12 Separating Unit, Crosswise Test

	Single-Operator Component	Within-Laboratory Component	Between-Laboratory Component
Separable Pin, Pull-Off	11.04	0	0
Fixed Retainer, Pull-Off	11.67	7.57	0
Separating Unit, Crosswise	7.64	0	2.87

32.2 *Precision*—For the components of variance reported in 32.1, two averages of observed values should be considered significantly different at the 90 % probability level if the following difference equals or exceeds the differences listed in Table 4 (Notes 2 and 3).

32.3 *Bias*—No justifiable statement can be made on the bias of the procedures in Test Methods D 2061 for determining the holding strengths of separable units, since the true value of the properties cannot be established by an accepted referee method.

RESISTANCE TO CUSHIONED COMPRESSION OF SLIDERS

33. Scope

33.1 This test method covers the determination of the compression resistance of a slider assembled on a zipper chain, with the pull in either the normal flat position or the 180° reverse position, when cushioned loads are applied perpendicularly to top and bottom slider planes.

34. Summary of Test Method

34.1 The lower platen of a compression tester is cushioned with a neoprene pad. The specimen is laid on the pad and a load

TABLE 4 Critical Differences for the Properties Listed

	Number of Observations in Each Average	Critical Differences, Percent of Grand Average for the Conditions Noted		
		Single-Operator Precision	Within-Laboratory Precision	Between-Laboratory Precision
Separable Pin, Pull-Off	1	25.7	25.7	25.7
	3	14.8	14.8	14.8
	5	11.5	11.5	11.5
	10	8.1	8.1	8.1
Fixed Retainer, Pull-Off	1	27.2	32.4	32.4
	3	15.7	23.6	23.6
	5	12.2	21.4	21.4
	10	8.6	19.6	19.6
Separating Unit, Crosswise	1	17.8	17.8	19.0
	3	10.2	10.2	12.2
	5	7.9	7.9	10.4
	10	5.5	5.5	8.7

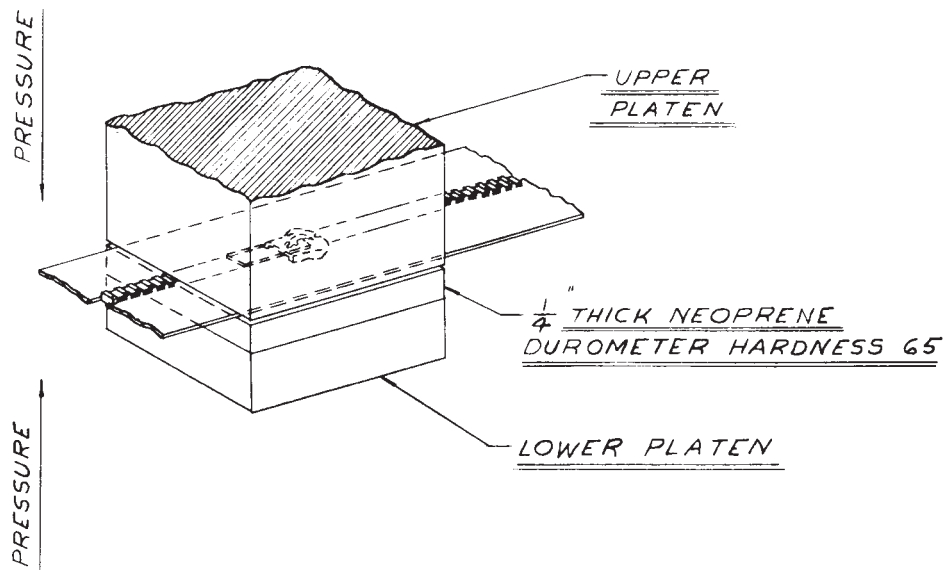

FIG. 13 Test for Slider Resistance to Cushioned Compression

applied. The effects of operability of the zipper is then determined.

35. Significance and Use

35.1 *Resistance to Cushioned Compression of Sliders*—This test method may be used to determine the crushing resistance of a slider which measures the ability of a slider to resist crushing, for example in pressing the end item, which could cause the slider to malfunction or become inoperative.

36. Apparatus

36.1 *Compression Testing Machine*⁶—A testing machine with upper and lower platens, one of which may be fixed and the other movable. The platens shall be hardened steel, 51 by 51 by 25 mm (2 by 2 by 1 in.) and their opposite faces shall be smooth and parallel to each other as shown in Fig. 13. The lower platen shall have attached to its entire surface a piece of neoprene rubber 6 mm ($\frac{1}{4}$ in.) in thickness and of 65 Durometer hardness. The compression testing machine shall be designed to permit the application of a load to the platens at a rate-of-traverse of approximately 13 mm ($\frac{1}{2}$ in.)/min. The load shall be measurable in increments of 44 N (10 lbf).

37. Test Specimen

37.1 The test specimen shall consist of a slider assembled on the zipper chain with which it is to be used. Two specimens are required.

38. Conditioning

38.1 No conditioning is required.

39. Procedure

39.1 Test the zipper for operability as directed in Opening and Closing in Test Methods D 2062.

39.2 Position the specimen centrally on the lower platen. Place the pull in the normal flat position, lying on the top of the slider as shown in Fig. 13. Apply a compression force at a rate-of-traverse of approximately 13 mm ($\frac{1}{2}$ in.)/min until it reaches the load required by the applicable specification. Release the compression force, remove the specimen from the apparatus and test it for operability as directed in 39.1.

39.3 On the second specimen, proceed as directed in 39.2 but with the pull of the slider 180° in the reverse position.

39.4 Test locking-type sliders that satisfactorily pass the requirements of 39.2 further as directed in Sections 82-90.

40. Evaluation

40.1 Consider breakage or deformation beyond that permitted by the applicable specification a failure. Examine each specimen to determine whether or not there remains the usual ease of manual movement of the pull.

⁶ A suitable laboratory press is available from Fred S. Carver, Inc., Summit, NJ 07901.

41. Report

41.1 State that the specimens were tested as directed in Sections 33-42 of Test Methods D 2061. Describe the material or product sampled and the method of sampling used.

41.2 Report the following information:

- 41.2.1 Specific property (or properties) evaluated,
- 41.2.2 Number and description of specimens tested, and
- 41.2.3 The observed values and nature of failures of each specimen.

42. Precision and Bias

42.1 No justifiable statement can be made either on the precision or on the bias of the procedures in Test Methods D 2061 for testing the resistance to cushioned compression of zipper sliders since the test result merely states whether there is conformance to the criteria for success expressed in the procedure. The precision and bias of Test Methods D 2061 for testing zipper operability are as specified in Test Methods D 2062.

SLIDER DEFLECTION AND RECOVERY

43. Scope

43.1 These test methods cover two procedures for determining the resistance of slider planes of zippers to an opening or spreading force. In one procedure the force is applied to the mouth of the slider. In the other, which is an alternative method, the force is applied through the slider pull and back plane of the slider.

44. Summary of Test Methods

44.1 Fixtures as shown in Figs. 14 and 15 are used with a tensile testing machine to apply a spreading force on the slider planes.

45. Significance and Use

45.1 *Slider Deflection and Recovery, Mouth*—This test method may be used to determine spreading resistance of a slider which measures the ability of a slider to retain control of the chain by resisting the spreading apart of its two halves when the slider mouth is stressed during operation of the zipper in the end-product.

45.2 *Slider Deflection and Recovery, Pull*—This test method may be used to determine spreading resistance of a slider which measures the ability of a slider to retain control of the chain by its resistance to the spreading apart of its two halves when the slider is stressed by a force on the slider pull during operation of the zipper in the end-product.

46. Apparatus

46.1 *Testing Machine*, as specified in 12.1.

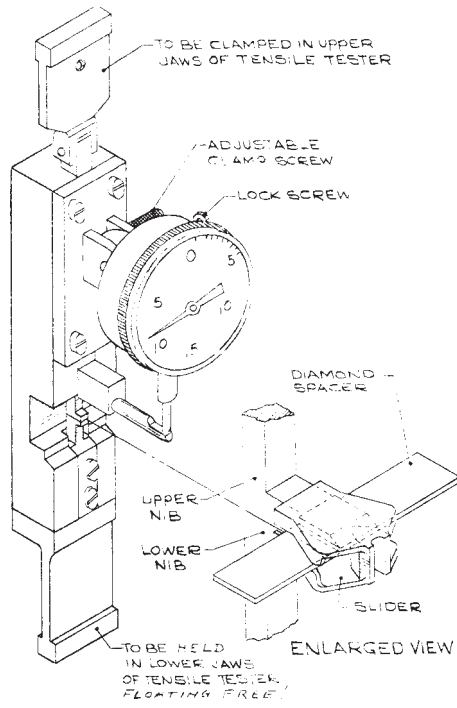

FIG. 14 Fixture for Slider Deflections Test (Mouth)

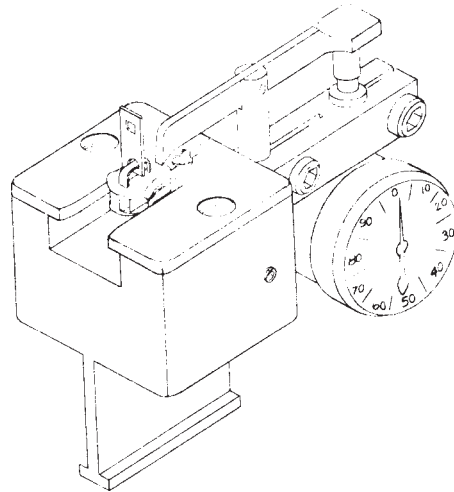

FIG. 15 Fixture for Slider Deflection Test (Pull)

46.2 *Slider Deflection Mouth Fixture*⁴—A fixture and dial gage as shown in Fig. 14.

46.3 *Diamond Spacer*, conforming to the requirements shown in Fig. 16 and used in conjunction with the slider deflection mouth fixture.

46.4 *Nibs*, conforming to the requirements shown in Fig. 16 and used in conjunction with the slider deflection mouth fixture.

46.5 *Slider Deflection Pull Fixture and Dial Gage*⁴, as shown in Fig. 15. The top plate of the fixture shall be changed to suit the size of the slider as shown in Fig. 17.

47. Test Specimen

47.1 The test specimen shall consist of a complete slider.

48. Conditioning

48.1 No conditioning is required.

49. Procedure

49.1 *Slider Deflection and Recovery, Mouth*—See Fig. 16 and, in accordance with the slider size, select the appropriate diamond

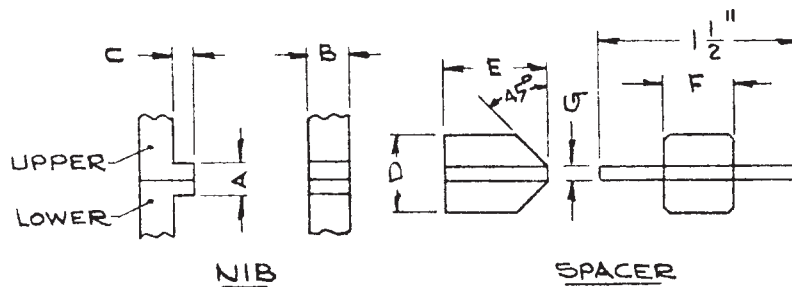

Zipper Size	Nib Dimensions, in. (mm)				Spacer Dimensions, in. (mm)			
	A	B	C	D	E	F	G	
1 and 2 (2.540 to 3.556)	1.168 (0.046)	2.921 (0.115)	3.125 (0.125)	1.168 (0.046)	2.352 (0.093)	2.921 (0.115)	0.406 (0.016)	
3 and 4 (3.581 to 5.080)	1.702 (0.067)	3.937 (0.155)	4.750 (0.187)	1.829 (0.072)	3.125 (0.125)	3.937 (0.155)	0.508 (0.020)	
5 and 6 (5.105 to 7.620)	2.286 (0.090)	5.588 (0.220)	5.537 (0.218)	2.413 (0.095)	4.750 (0.187)	5.588 (0.220)	0.762 (0.030)	
7, 8 and 9 (7.645 to 10.160)	3.302 (0.130)	8.255 (0.325)	8.712 (0.343)	3.429 (0.135)	7.137 (0.281)	8.255 (0.325)	1.016 (0.040)	
10 (10.185 to 12.700)	4.699 (0.185)	11.430 (0.450)	9.525 (0.375)	4.826 (0.190)	8.712 (0.343)	11.430 (0.450)	1.524 (0.060)	

FIG. 16 Dimensions of Nib and Spacer

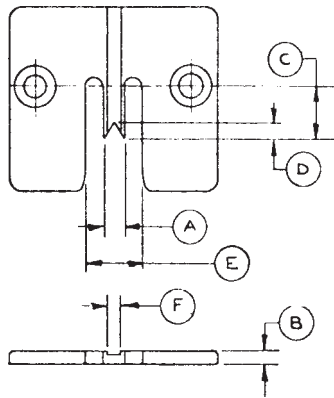

Dimension	Plate Dimensions, mm (in.)				
	Zipper Sizes				
	1 and 2	3 and 4	5 and 6	7, 8, and 9	10
A	2.540 (0.100)	3.556 (0.140)	4.953 (0.195)	7.620 (0.300)	10.160 (0.400)
B	1.168 (0.046)	1.702 (0.067)	2.286 (0.090)	3.302 (0.130)	4.699 (0.185)
C	7.620 (0.300)	10.160 (0.400)	12.700 (0.500)	18.415 (0.725)	25.400 (1.000)
D	2.159 (0.085)	3.048 (0.120)	4.318 (0.170)	6.350 (0.250)	8.890 (0.350)
E	0.525 (0.375)	12.065 (0.475)	13.970 (0.550)	19.685 (0.775)	22.860 (0.900)
F	1.575 (0.062)	2.362 (0.093)	3.175 (0.125)	3.175 (0.125)	3.962 (0.156)

FIG. 17 Dimensions of Top Plate

spacer and nibs to be used. Insert the selected diamond spacer transversely through the slider as shown in Fig. 14. Leave the diamond spacer in place throughout the test. Place the slider mouth over the selected nibs on the slider deflection mouth fixture, making certain that the nibs abut the diamond spacer. Apply an initial load of 4.4 N (1 lbf) and then set the deflection indicator dial to zero. Apply the load specified for the size of the zipper being tested as shown in Table 5 at a constant rate-of-traverse of approximately 13 mm (½ in.)/min. Read and record the measurement of the deflection on the dial indicator. Reduce the load to 4.4 N (1 lbf). Again read the measurement on the dial indicator. Record any reading above zero as the amount of permanent set.

49.2 *Slider Deflection and Recovery, Pull*—Fasten the slider deflection pull fixture in the lower clamp of the tensile testing machine. Place the slider to be tested on the fixture so that the fixture enters the mouth first and the diamond enters the notch of the top plate as shown in Fig. 16. Connect the pull to the top clamp of the tensile testing machine with a suitable hook or thong so that the pull is at a right angle to the slider body. If the design permits lengthwise travel of the pull along a lug or cap, the pull should be positioned so that it is midway in its length of travel. Adjust the dial gage so that the measuring tip is on the top surface of the top plane and as close as possible to the mouth end. Apply an initial load of 1 lb and set the dial to zero. Apply the load specified for the size of the zipper tested as shown in Table 6 at a constant rate-of-traverse of approximately 13 mm (½ in.)/min. Read and record measurement of the deflection on the dial indicator. Reduce the load to 4.4 N (1 lbf) and read the measurement on the dial indicator again. Record any reading above zero as the amount of permanent set.

50. Report

50.1 State that the specimens were tested as directed in Sections 43-51 of Test Methods D 2061. Describe the material or product sampled and the method of sampling used.

TABLE 5 Testing Loads for Slider Deflection Tests—Mouth Tests

Zipper size	Load	
	N	lbf
1, 2, 3, 4	67	15
5, 6	111	25
7, 8, 9, 10	178	40

TABLE 6 Testing Loads for Slider Deflection Tests—Pull Tests

Zipper Size	Load	
	N	lbf
1, 2, 3, 4	89	20
5, 6	133	30
7, 8, 9, 10	222	50

50.2 Report the following information:

50.2.1 The specific property (or properties) evaluated,

50.2.2 Number and description of specimens, and

50.2.3 The deflection and permanent set of each specimen.

51. Precision and Bias

51.1 The precision of this test method is such that it is not recommended for acceptance testing, particularly with small samples, except when the bias, if any, of the laboratories of purchaser and seller has been established.

51.2 *Interlaboratory Test Data*⁵—An interlaboratory test was conducted as described in 16.1. The components of variance expressed as coefficients of variation, percent relative, were calculated to be:

	Single-Operator Component	Within-Laboratory Component	Between-Laboratory Component
Slider Deflection and Recovery, Mouth	66.51	25.21	179.85
Slider Deflection and Recovery, pull	34.43	0	70.27

51.3 *Precision*—For the components of variance reported in 51.2, two averages of observed values should be considered significantly different at the 90 % probability level if the difference equals or exceeds the critical differences listed in Table 6 (Notes 2 and 3).

51.4 *Bias*—No justifiable statement can be made on the bias of the procedures in Test Methods D 2061 for determining the strength of the slider, since the true value of the property cannot be established by an accepted referee method.

RESISTANCE TO TWIST OF PULL AND SLIDER

52. Scope

52.1 This test method covers the determination of the twist resistance of a pull-and-slider assembly against a torsional force applied to the pull of a zipper in a plane perpendicular to its longitudinal axis.

53. Summary of Test Method

53.1 A fixture as shown in Fig. 18 is used with a torque wrench to apply a specified twisting force to a slider pull. The amount of permanent twist imparted to the slider pull or other permanent damage or deformation is noted.

54. Significance and Use

54.1 *Resistance to Twist of Pull and Slider*—This test method may be used to determine slider pull strength which measures the ability of a slider pull or pull assembly, either or both, to resist deformation or rupture when a torsional stress is applied on the pull during operation of the zipper in the end-product.

55. Apparatus

55.1 *Pull Twist Test Fixture Assembly*,⁴ consisting of a pull twist fixture having a means for positioning the slider body, and for clamping the pull perpendicularly to the slider body as shown in Fig. 18. The pull clamp shall be rotatable around its longitudinal axis and shall be equipped with a dial for measuring the angle of rotation. Provision shall be made to apply torsional forces to the clamp by means of torque wrenches of the adjustable slip type at the rate of approximately 9°/s. The wrench selected for each test shall be such that the torsional force exerted falls between 20 and 80 % of its scale capacity.

56. Test Specimen

56.1 The test specimen shall consist of a complete pull-and-slider assembly. Two specimens are required.

57. Conditioning

57.1 No conditioning is required.

58. Procedure

58.1 Attach the slider in the pull twist test fixture. Position the pull in the clamp, aligning the front surface of the clamp with the midpoint of the pull as shown in Fig. 18. Turn the testing drum clockwise until the clearance between the lug and the pull

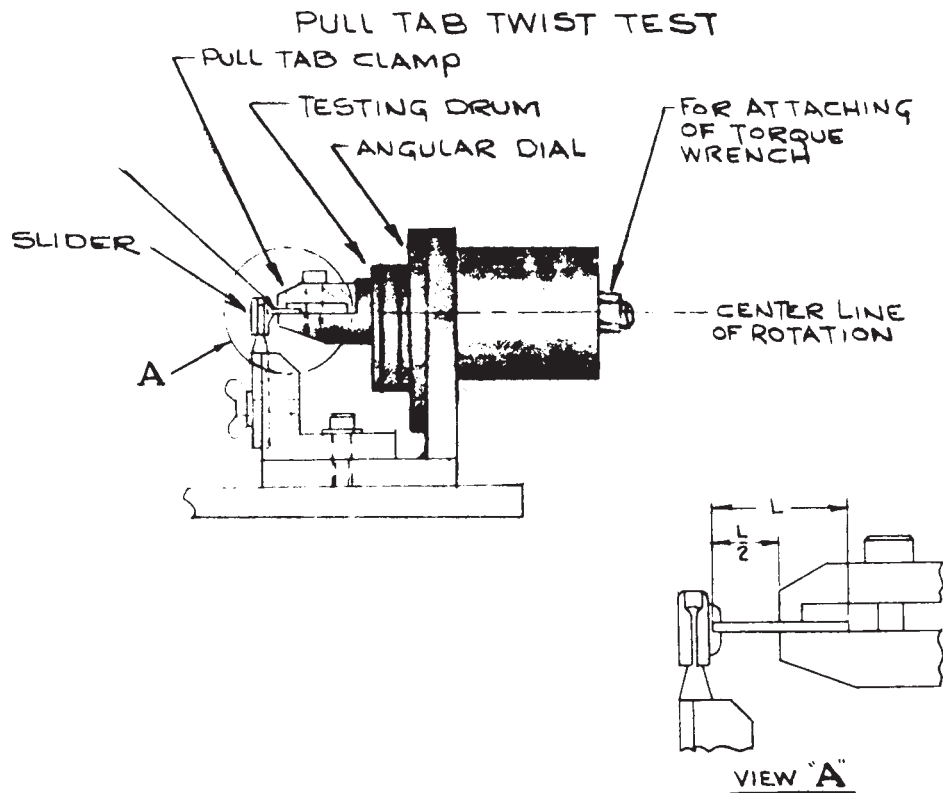

FIG. 18 Apparatus for Twist for Slider Pull Tab

trunnions is taken up, and then set the dial to zero.

58.2 Use the appropriate torque wrench and at the rate of approximately 9°/s apply the torsional force required by the applicable specification. Release the torsional force. Turn the testing drum by hand in the direction of the torsional force until the clearance is taken up. Read the dial and record the amount of permanent twist. Remove the slider.

58.3 On the second specimen, repeat the test as directed in 58.1 and 58.2 except that the direction of rotation shall be counterclockwise.

59. Evaluation

59.1 Examine the specimens and note the effects of the test, such as breaking or deformation of the lug or any other part of the assembly.

60. Report

60.1 State that the specimens were tested as directed in Sections 52-61 of Test Methods D 2061. Describe the material or product sampled and the method of sampling used.

60.2 Report the following information:

60.2.1 The property evaluated,

60.2.2 Number and description of specimens, and

60.2.3 Any failures or deformations that occur and the amount of permanent twist as well as the direction of rotation for each specimen.

61. Precision and Bias

61.1 The precision of this test method is such that it is not recommended for acceptance testing of commercial shipments, particularly with small samples, except when the bias, if any, between the laboratories of the purchaser and of the seller has been established.

61.2 *Interlaboratory Test Data*⁵—An interlaboratory test was conducted as described in 16.1. The components of variance expressed as coefficients of variation, percent relative, were calculated to be:

	Single-Operator Component	Within-Laboratory Component	Between-Laboratory Component
Resistance to Twist of Pull and Slider	36.7	0	61.5

61.3 *Precision*—For the components of variance reported in 61.2, two averages of observed values should be considered significantly different at the 90 % probability level if the difference equals or exceeds the critical differences listed in Table 7 (Notes 2 and 3).

61.4 *Bias*—No justifiable statement can be made on the bias of the procedures in Test Methods D 2061 for determining the resistance to twist of pull and slider, since the true value of the properties cannot be established by an accepted referee method.

RESISTANCE TO PULL-OFF OF SLIDER PULL

62. Scope

62.1 This test method covers the determination of resistance to pull-off of the pull in a pull-and-slider zipper assembly, the pull being at right angles to the top plane of the slider.

63. Summary of Test Method

63.1 A special fixture as shown in Fig. 19 is used with a tensile testing machine to apply a load through the pull to the slider.

64. Significance and Use

64.1 *Resistance to Pull-Off of Slider Pull*—This test method may be used to determine slider pull strength, which measures the resistance of the pull or pull assembly, either or both, to rupture, deformation or separation when a stress is perpendicularly applied through the pull during operation of the zipper in the end-product.

65. Apparatus

65.1 *Testing Machine*, as specified in 12.1.

65.2 *Slider Pull Fixture*,⁴ as illustrated in Fig. 19, to hold the slider body.

66. Test Specimen

66.1 The specimen shall consist of a complete pull-and-slider assembly.

67. Conditioning

67.1 No conditioning is required.

68. Procedure

68.1 Secure the slider pull fixture in the upper clamp of the testing machine. Place the slider body horizontally on the fixture, with the pull projecting vertically downward, so that both the bail and pull are clear and unrestricted as shown in Fig. 19. Position the trunnions midway in the length of the bails which are of the elongated type. Hook the other part of the fixture into the pull, and secure it in the bottom clamp of the testing machine. Apply the load required by the applicable specification.

69. Evaluation

69.1 Examine the specimen and note the effects of the test, such as breakage, rupture, deformation, or separation of the pull from the slider body of the zipper.

70. Report

70.1 State that the specimens were tested as directed in Sections 62-71 of Test Methods D 2061. Describe the material or product sampled and the method of sampling used.

70.2 Report the following information:

70.2.1 Number and description of specimens, and

70.2.2 Load applied and the type of failure, if any.

TABLE 7 Critical Differences for the Properties Listed

	Number of Observations in Each Average	Critical Differences, Percent of Grand Average for the Conditions Noted		
		Single-Operator Precision	Within-Laboratory Precision	Between-Laboratory Precision
Slider Deflection and Recovery, Mouth	1	154.7	165.4	449.9
	3	89.3	106.9	431.8
	5	69.2	90.7	428.1
	10	48.9	76.4	425.2
Slider Deflection and Recovery, Pull	1	80.1	80.1	182.1
	3	46.2	46.2	169.9
	5	35.8	35.8	167.4
	10	25.3	25.3	165.4

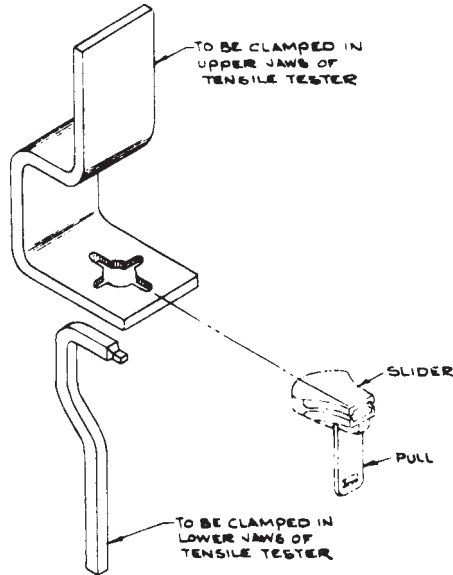

FIG. 19 Fixture for Slider Pull, Pull-Off Test

71. Precision and Bias

71.1 No justifiable statement can be made either on the precision or on the bias of the procedures in Test Methods D 2061 for testing resistance to pull-off of slider pull, since the test merely states whether there is conformance to the criteria for success expressed in the procedure.

RESISTANCE TO ANGULAR PULL-OFF OF SLIDER PULL

72. Scope

72.1 This test method covers the determination of the resistance to pull-off of the pull in a pull-and-slider zipper assembly, the pull being at 135° to the top planes of the slider as rotated from the mouth end.

73. Summary of Test Method

73.1 A special fixture as shown in Fig. 20 is used with a tensile testing machine to apply a load through the pull to the slider

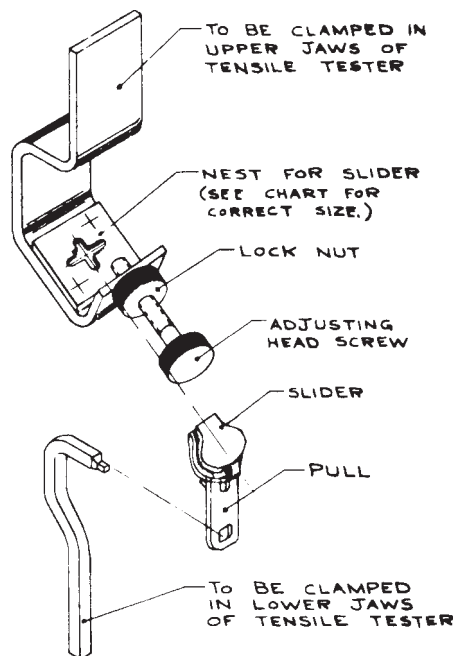

FIG. 20 Fixture for Angular Pull, Pull-Off Test

of the zipper.

74. Significance and Use

74.1 *Resistance to Angular Pull-Off of Slider Pull*—This test method may be used to determine slider pull strength which measures the resistance of the pull or pull assembly, either or both, to rupture, deformation or separation when a stress is applied at an angle during operation of the zipper in the end-product.

75. Apparatus

75.1 *Testing Machine*, as specified in 12.1.

75.2 *Angular Pull Fixture*⁴ to hold the slider body as shown in Fig. 20.

76. Test Specimen

76.1 The test specimen shall consist of a complete pull-and-slider assembly.

77. Conditioning

77.1 No conditioning is required.

78. Procedure

78.1 Secure the angular pull fixture in the upper clamp of the testing machine. Place the slider body in the fixture, with the pull projecting vertically downward, so that both the bail and the pull are clear and unrestricted. This is accomplished by abutting the adjusting screw against the diamond end of the slider body (see Fig. 20). Hook the other part of the fixture into the pull and then secure it in the bottom clamp of the testing machine. Apply the load required by the applicable specification.

79. Evaluation

79.1 Examine the specimen and note the effects of the test, such as breakage, rupture, deformation, or separation of the pull from the slider body.

80. Report

80.1 State that the specimens were tested as directed in Sections 72-81 of Test Methods D 2061. Describe the material or product sampled and the method of sampling used.

80.2 Report the following information:

80.2.1 Number and description of specimens, and

80.2.2 Load applied and type of failure, if any.

81. Precision and Bias

81.1 No justifiable statement can be made either on the precision or on the bias of the procedures in Test Methods D 2061 for testing resistance to angular pull-off of slider pull, since the test merely states whether there is conformance to the criteria for success expressed in the procedure.

HOLDING STRENGTH OF SLIDER LOCK

82. Scope

82.1 This test method covers the determination of the lock holding strength of the slider assembled on a zipper chain.

83. Summary of Test Method

83.1 The locking strength of the slider is determined by stressing the stringers of a zipper between the jaws of a tensile testing machine.

84. Significance and Use

84.1 *Holding Strength of Slider Lock*— This test method may be used to determine the locking strength of a slider which measures the ability of the locking mechanism of a slider to hold the slider in a locked position on the chain when stress is applied through the stringers.

NOTE 4—There are two types of slider locking mechanisms: positive lock and ratchet lock (see Terminology D 2050). The positive lock holds the slider in position until failure occurs; the ratchet lock permits the slider to slip along the chain upon application of a predetermined force so as to prevent damage that would impair either the service or use of the slider or chain.

85. Apparatus

85.1 *Testing Machine*, as specified in 12.1.

TABLE 8 Critical Differences for the Properties Listed

	Number of Observations in Each Average	Critical Differences, Percent of Grand Average for the Conditions Noted		
		Single-Operator Precision	Within-Laboratory Precision	Between-Laboratory Precision
Resistance to Twist of Pull and Slider	1	85.4	85.4	166.5
	3	49.3	49.3	151.2
	5	38.2	38.2	148.0
	10	27.0	27.0	145.5

86. Test Specimen

86.1 The test specimen shall consist of a slider assembled on the zipper chain with which it is to be used.

87. Procedure

87.1 Set the distance between the clamps of the testing machine at approximately 76 mm (3 in.). Locate and lock the slider midway between the ends of the chain. Secure one of the stringers emerging from the throat of the slider in the upper clamp and one in the lower clamp of the testing machine. Position the slider body along the axis of the clamps and midway between them as shown in Fig. 21. Apply the load required by the applicable specification.

88. Evaluation

88.1 Examine the specimen to determine the effects of the test, such as lock slippage, lock damage, tape or interlockable element damage affecting zipper functioning.

89. Report

89.1 State that the specimens were tested as directed in Sections 82-90 of Test Methods D 2061. Describe the material or product sampled and the method of sampling used.

89.2 Report the following information:

89.2.1 Number and description of specimens, and

89.2.2 The nature of the failure, if any, and the terminal load applied.

90. Precision and Bias

90.1 No justifiable statement can be made either on the precision or on the bias of the procedures in Test Methods D 2061 for testing holding strength of slider lock, since the test merely states whether there is conformance to the criteria for success expressed in the procedure.

91. Keywords

91.1 strength; zipper

ASTM International takes no position respecting the validity of any patent rights asserted in connection with any item mentioned in this standard. Users of this standard are expressly advised that determination of the validity of any such patent rights, and the risk of infringement of such rights, are entirely their own responsibility.

This standard is subject to revision at any time by the responsible technical committee and must be reviewed every five years and if not revised, either reapproved or withdrawn. Your comments are invited either for revision of this standard or for additional standards and should be addressed to ASTM International Headquarters. Your comments will receive careful consideration at a meeting of the responsible technical committee, which you may attend. If you feel that your comments have not received a fair hearing you should make your views known to the ASTM Committee on Standards, at the address shown below.

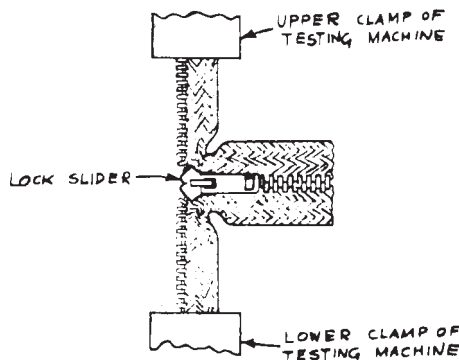

FIG. 21 Slider Lock Holding, Stringer Separation Test

This standard is copyrighted by ASTM International, 100 Barr Harbor Drive, PO Box C700, West Conshohocken, PA 19428-2959, United States. Individual reprints (single or multiple copies) of this standard may be obtained by contacting ASTM at the above address or at 610-832-9585 (phone), 610-832-9555 (fax), or service@astm.org (e-mail); or through the ASTM website (www.astm.org).