



Standard Test Methods for Testing Tire Cords, Tire Cord Fabrics, and Industrial Yarns Made From Glass Filaments¹

This standard is issued under the fixed designation D 2970; the number immediately following the designation indicates the year of original adoption or, in the case of revision, the year of last revision. A number in parentheses indicates the year of last reapproval. A superscript epsilon (ε) indicates an editorial change since the last revision or reapproval.

1. Scope

1.1 These test methods cover the testing of industrial yarns made of glass filaments, cords twisted from such yarns, and fabric woven from such cords—products that are made specifically for use in the manufacture of pneumatic tires. By agreement, these test methods may be applied to similar glass yarns and cords used for reinforcing other rubber goods and for other industrial applications. The yarn or cord may be wound on cones, tubes, bobbins, spools, or beams, woven into fabric, or in other forms. These test methods include testing procedures only. These test methods do not include specifications or tolerances.

1.2 No procedure is included for the determination of fatigue resistance of cords, but several articles relating to the measurement of fatigue resistance of cords made from man-made filaments and cured in rubber were published in the bibliography of Test Methods D 885.

1.3 The following sections are included:

Adhesion of Cords to Elastomers	Section 24
Breaking Strength (Force) of Conditioned Yarns and Cords	13
Breaking Tenacity of Conditioned Yarns and Cords	14
Catenary Length of Cords	Appendix X1
Conditioning	8
Construction of Yarns and Cords	18
Count of Tire Cord Fabric	22
Dip Pick-Up (DPU) on Yarns and Cords	23
Elongation at Break of Conditioned Yarns and Cords	15
Initial Modulus of Conditioned Yarns and Cords	16
Keywords	28
Mass of Tire Cord Fabric	22
Precision and Bias	25-27
Sampling of Yarn and Cord	6
Sampling of Tire Cord Fabric	7
Tensile Properties of Yarns and Cords	9-17
Terminology	3
Thickness of Cords	21
Twist in Yarns and Cords	20
Width of Tire Cord Fabric	22
Yarn Number of Dipped Yarns and Cords	19

1.4 These test methods show the values in both SI units and in inch-pound units. “SI units” is the technically correct name

for the system of metric units known as the International System of Units. “Inch-pound units” is the technically correct name for the customary units used in the United States. The values stated in either acceptable metric units or other units shall be regarded separately as standard. The values expressed in each system may not be exact equivalents; therefore, each system must be used independently of each other without combining values in any way.

1.5 *This standard does not purport to address all of the safety concerns, if any, associated with its use. It is the responsibility of the user of this standard to establish appropriate safety and health practices and determine the applicability of regulatory limitations prior to use.*

2. Referenced Documents

2.1 ASTM Standards:

- D 76 Specification for Tensile Testing Machines for Textiles²
- D 123 Terminology Relating to Textile²
- D 578 Specification for Glass Fiber Strands²
- D 885 Methods for Tire Cords, Tire Cord Fabrics, and Industrial Filament Yarns Made from Manufactured Organic-Base Fibers²
- D 1423 Test Method for Twist in Yarns by the Direct-Counting Method²
- D 2258 Practice for Sampling Yarn for Testing²
- D 4393 Test Method for Strap Peel Adhesion of Reinforcing Cords or Fabrics to Rubber Compounds³
- D 4848 Terminology of Force, and Deformation Properties of Textiles³
- D 6477 Terminology Relating to Tire Cord and Fabrics³

3. Terminology

3.1 Definitions:

- 3.1.1 For definitions of terms related to tire cord and fabrics, refer to Terminology D 6477.
- 3.1.2 For definitions of terms related to force and deformation in textiles, refer to Terminology D 4848.
- 3.1.3 For definitions of other terms related to textiles, refer to Terminology D 123.

¹ These test methods are under the jurisdiction of ASTM Committee D13 on Textiles and are the direct responsibility of Subcommittee D13.19 on Tire Cord and Fabrics.

Current edition approved April 10, 2002. Published June 2002. Originally published as D 2970M – 80. Discontinued November 1995 and reinstated as D 2970 – 95. Last previous edition D 2970/D 2970M – 98^{ε1}.

² Annual Book of ASTM Standards, Vol 07.01.

³ Annual Book of ASTM Standards, Vol 07.02.

3.2 Abbreviation:

3.2.1 CRE—constant-rate-of-extension

4. Summary of Test Methods, General

4.1 A summary of the directions prescribed for the determination of specific properties is stated in the appropriate sections of specific test methods or the referenced standard.

5. Significance and Use

5.1 The procedures in these test methods may be used for the acceptance testing of commercial shipments, but caution is advised because technicians may fail to get good agreement between results on certain yarns, cords, or fabrics. Comparative tests as directed in Section 5.1.1 may be advisable.

5.1.1 If there are differences of practical significance between reported test results for two laboratories (or more), comparative tests should be performed to determine if there is a statistical bias between them, using competent statistical assistance. As a minimum, test samples should be used that are as homogeneous as possible, that are drawn from the material from which the disparate test results were obtained, and that are randomly assigned in equal numbers to each laboratory for testing. Other materials with established test values may be used for this purpose. The test results from the two laboratories should be compared using a statistical test for unpaired data, at a probability level chosen prior to the testing series. If a bias is found, either its cause must be found and corrected, or future test results for that material must be adjusted in consideration of the known bias.

5.2 The significance and use of particular properties are discussed in the appropriate sections of the specific test methods.

SAMPLING AND CONDITIONING

6. Sampling of Yarn and Cord

6.1 *Lot Sample*—As a lot sample for acceptance testing, take at random the number of shipping cases or beams directed in an applicable material specification or Practice D 2258. Consider shipping cases to be the primary sampling unit.

6.2 Laboratory Sample:

6.2.1 *Yarn or Cord in Cases*—As a laboratory sample for acceptance testing, select packages at random from each shipping case in the lot sample. Take the number of packages for the laboratory sample as directed in an applicable material specification or Practice D 2258. Preferably, the same number of packages should be taken from each shipping case in the lot sample. If differing numbers of packages are to be taken from shipping cases in the lot sample, the cases from which a specific number of packages are to be drawn should be determined at random.

6.2.2 *Yarn on Beams*—As a laboratory sample for acceptance testing, select ends at random from each beam in the lot sample. Take the number of ends for the laboratory sample as directed in an applicable material specification or Practice D 2258. Wind the laboratory samples on a tube or spool using a winder with a tension of 5 ± 1 mN/tex (0.05 ± 0.01 gf/den) using the general technique directed in Practice D 2258.

6.2.2.1 Take laboratory samples from the outside of the beams unless there is a question or disagreement about a

shipment. In that case, take laboratory samples after removing a radial depth of 6 mm ($\frac{1}{4}$ in.) or more to minimize the effects of handling and atmospheric changes that occurred during shipment or storage. Place the laboratory samples in a moisture resistant container to protect them from atmospheric changes until the yarn is conditioned in the atmosphere for testing tire cords and industrial yarns.

6.3 *Test Specimens*—Take the number of specimens from each laboratory sampling unit as directed in each test method.

6.3.1 *Preparation of Specimens*—Unwind and discard at least six layers of yarn or cord from the package to eliminate ultraviolet and physically damaged material (except from beams). If specimens are not taken directly from the original package, it is advisable to wind the sample on a tube or spool by means of a winder using a tension of 5 ± 1 mN/tex (0.05 ± 0.01 gf/den). If the specimen is collected as a loosely wound package, or in the form of a skein, report that the observed results were determined on a relaxed sample. Use care in handling the specimen. Discard any specimen subjected to any change of twist, kinking or making any bend with a diameter less than 6 mm ($\frac{1}{4}$ in.). Place the specimen in a moisture resistant polyethylene bag or other moisture resistant container to protect it from atmospheric changes until ready to condition in the atmosphere for testing industrial yarns and tire cords.

6.3.2 If the yarn or cord has been treated with a resorcinol-formaldehyde-latex (RFL) type adhesive, samples should be protected against exposure to ultraviolet light, high humidity (over 60 % relative humidity) and high temperature (over 38°C (100°F)).

7. Sampling of Tire Cord Fabric

7.1 *Lot Sample*—As a lot to be sampled for acceptance testing, take tire cord fabric produced on only one loom creel. As a primary sampling unit, select one roll of fabric from the lot and prepare tabby sample to yield the laboratory sampling units as directed in Section 7.2.

7.2 *Preparation of Laboratory Sample*—Take a sample equal to the length of cord between the regular tabby woven at the end of the roll and a special tabby woven a short distance from the end when the roll of fabric is manufactured. For rolls that do not have a special woven tabby, improvise a tabby by the use of gummed tape or strips of cemented fabric applied across a section of the cord fabric. The length of the tabby sample shall be as agreed upon by the purchaser and the supplier. The recommended minimum is 0.5 m (18 in.). The width of the sample shall be at least one tenth of the roll width. Cut the warp cords of the fabric along the center line of the special tabby across for a distance equal to the width of the required sample. If this distance is less than the full width of the fabric, cut the filling yarns of the sample and of the special and regular tabbies in the direction parallel with the warp cords. The resulting section of cord fabric is the tabby sample. Attach the tabby sample to a piece of cardboard or fiber board, the length of which shall be equal to at least the length of the cord warp between tabbies. Fold the tabby portions of the sample over each end of the board, and secure the sample to the board with pressure-sensitive tape or staples. Use care to avoid contact of tape or staples with the area to be tested. Handle the sample carefully and hold it under sufficient tension in the warp

direction to prevent the cords from kinking. The board with the sample may be folded lengthwise and parallel with the warp for convenience. Place the board with the fabric sample in a polyethylene bag, or wrap it with several layers of polyethylene film to protect the sample from changes in atmospheric moisture content until ready to condition in the atmosphere for testing industrial yarns and tire cords. Use care during subsequent handling of the sample to prevent any change in the cord twist and to avoid kinking of the cords in the area to be tested.

7.3 Test Specimens—Take the number of specimens at random from each laboratory sampling unit as directed in each of the specific test methods.

8. Conditioning

8.1 Bring all specimens of yarn, cord, and fabric to moisture equilibrium for testing in the atmosphere for testing industrial yarns and tire cords.

TENSILE PROPERTIES OF YARNS AND CORDS

9. Scope

9.1 These tests are used to determine the tensile properties of yarns and cords.

10. Summary of Test Method

10.1 A continually increasing force is applied longitudinally to a conditioned specimen of yarn or cord placed in the clamps of a tensile testing machine until broken. The breaking force and elongation are observed depending upon the option employed. Two clamping options are provided: Option 1, drum clamp; and Option 2, pneumatically-operated clamps having fixed snubbing surfaces that are integral with one of the clamping surfaces. Elongation and modulus are calculated from the force-extension curve when using Option 2. Breaking tenacity is calculated using yarn number.

11. Significance and Use

11.1 In some laboratories, the output of the CRE-type of tensile testing machine may be connected with electronic recording and computing equipment that may be programmed to calculate and print the results of tests for each required property. Because of the variety of electronic equipment available, and the various possibilities for recording test data, use of this type of equipment is not covered in this test method.

11.2 The levels of tensile properties obtained when testing industrial yarns and tire cords are dependent to a certain extent on the age and history of the sample and on the specific conditions used during the test. Among these conditions are rate of tensioning, type of clamps, gage length of specimen, temperature and humidity of the atmosphere, rate of airflow across the specimen, and temperature and moisture content of the specimen. Testing conditions accordingly are specified precisely to give reproducible test results on a specific sample.

11.3 Because the load-bearing ability of a reinforced rubber product is related to the strength of the yarn or cord used as a reinforcing material, breaking strength is used in engineering calculations when designing various types of textile reinforced rubber products. When intrinsic strength characteristics of yarns and cords of different sizes or different types of fiber are

to be compared, breaking tenacity is very useful, because for most types of fiber, breaking force is approximately proportional to linear density.

11.4 The drum clamp option gives a more accurate measure of strength since it minimizes the effect of clamping and is recommended when strength only is required. Elongation and modulus are not readily measured by this option.

11.5 The pneumatic-type clamp option provides for the measurement of strength, elongation, and modulus. However, the strength of the yarn or cord may be lower and subject to greater variation due to the effect of clamping.

11.6 Elongation of yarn or cord is taken into consideration in the design and engineering of reinforced rubber products because of its effect on uniformity of the finished product and its dimensional stability during service.

11.7 Modulus is a measure of the resistance of yarn or cord to extension as a force is applied. It is useful for estimating the response of a textile-reinforced structure to the application of varying force and its rate. Although modulus may be determined at any specified force, initial modulus is the value most commonly used.

11.8 It should be emphasized that, although the preceding parameters are related to the performance of a textile-reinforced product, the actual configuration of the product is significant. Shape, size, and internal construction also can have appreciable effect on product performance. It is not possible, therefore, to evaluate the performance of a textile reinforced product in terms of the reinforcing material alone.

12. Apparatus

12.1 *Tensile Testing Machine*—A single-strand CRE-type tensile testing machine. The specifications and methods of calibration and verification of this machine shall conform to Specification D 76. The testing machine shall be suitable for operation at a rate of crosshead travel not to exceed response of the read-out device to follow force and speed changes. The machine shall be equipped with an autographic recorder (rectilinear coordinates preferred) or digital read-out.

12.1.1 In these test methods, a machine speed of 5 ± 0.2 mm/s (12 ± 0.5 in./min) is specified.

12.2 *Clamps*:

12.2.1 *Option 1, Drum Clamps*, (1800 to 2200 N (400 to 500 lb) capacity)—see Fig. 1 for clamps that conform to the drawing in Fig. 2. The clamps must be equipped with rubber sleeves, 50-55 Type A Durometer, 1.6 by 50.0 wide by 90.0



FIG. 1 Drum Clamps—Option One

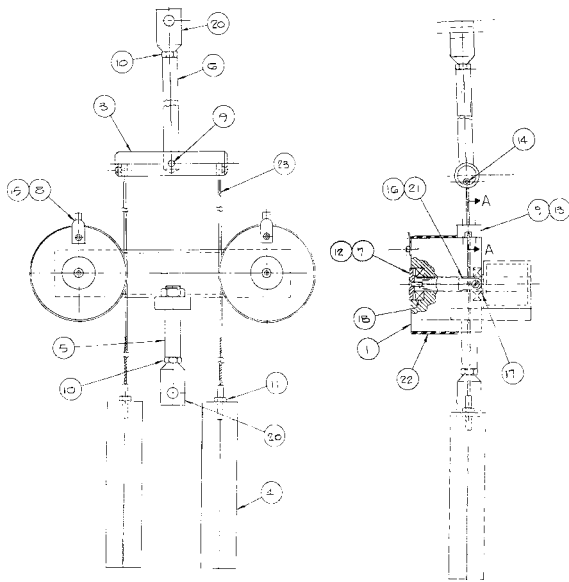

METRIC SIZES

DET	ITEM	QTY	DESCRIPTION	Material
1	A	2	BAR 102 mm (Diameter × 76 mm LG	STEEL
2	B	1	Tubing 50 mm sq × 3.2 mm W × 248 mm LG	STEEL
	C	2	50 mm × 50 mm × 3.2 mm	STEEL PL
	D	2	BAR 16 mm Diameter × 125 mm LG	STEEL
	E	1	33 mm × 86 mm × 13 mm	STEEL BAR
3	F	1	25 mm Diameter × 120 mm LG	STEEL BAR
4	G	2	38 mm Diameter × 178 mm LG	STEEL BAR
5	H	1	16 mm Diameter × 76 mm LG	STEEL BAR
6	J	1	16 mm Diameter × 330 mm LG	STEEL BAR
7	K	2	35 mm Diameter × 4.8 mm LG	STEEL BAR
8	L	2	25 mm × 13 mm × 3.04 mm	BLUE SPRING STEEL
9	M	2	25 mm × 13 mm × 7.9 mm	STEEL BAR
10	...	2	HEX. JAM NUT 10 mm-1.5	CHROME PLATED
11	...	2	HEX. JAM NUT 6 mm-1	CHROME PLATED
12	...	2	FLAT SOCHD. SCR #10-0.7150 × 13 mm	...
13	...	4	SOC. HD. CAPSCR. 5 mm-0.8150 × 13 mm	...
14	...	2	SOC. HD. SETSCR 6 mm-1.0150 × 6 mm	...
15	...	2	SOC. HD. CAPSCR. 3 mm-0.5150 × 6 mm	...
16	...	2	ROUND HD. SCR. #10-0.7150 × 10 mm	CAD PLATE
17	...	2	"BOSTON" WASHER #18838	16 mm I.D. × 1.6 mm T
18	...	4	"NICE" BEARING C10-D5	16 mm I.D.
19	...	1	HARDENED STEEL PIN 6 mm φ × 25 mm	...
20	...	2	"SCOTT" QCC-1 PREC. SCIEN. FITT.	...
21	...	2	"H.H. SMITH 4.8 mm NYLON CLAMP	#8956
22	...	2	SLEEVE - "CASTLE RUBBER CO."	...
23	...	2	CABLE ASSY-MACWHYTE CO.	...

FIG. 2 Drawing for Drum Clamps for Option One Tensile Properties Procedure

mm diameter (0.0625 by 2.0 wide by 3.5 in. diameter). Check each rubber sleeve for Type A hardness to ensure conformance to the 50-55 Durometer requirement.

12.2.2 *Option 2, Pneumatic-Type Clamps*, having fixed snubbing surfaces that are integral with one of the clamping surfaces. The snubbing surfaces may be circular with a diameter not less than 12.5 mm (0.5 in.) or semi-involute.

13. Procedure for Breaking Strength (Force) of Conditioned Yarns and Cords

13.1 Option 1, Drum Clamps:

13.1.1 *Number of Specimens*—Determine the breaking force of ten specimens from each lot sampling unit.

13.1.2 *Preparation of Apparatus*—Select a force scale such that the estimated breaking force of the specimen will fall in the range from 10 to 90 % of the full scale range in use. The range selected must be capable of handling twice the strength of the material. Insert the drum clamps in the tensile testing machine so that the spring steel cord clamping clip on the left drum is at approximately an eleven o'clock position. Adjust, if necessary, by turning the top thread rod in the direction required to bring the clip to the appropriate position. The cables that support the counterweights should pass in front of the cables connected to the yoke. The distance between the drums is fixed at 200 mm (8 in.), center to center. Examine rubber sleeves and replace as required (see Note 1). In these test methods, set the rate of crosshead travel to 5 ± 0.2 mm/s (12 ± 0.5 in./min). This results in a strain rate of 10 mm/s (24 in./min) applied to the specimen.

NOTE 1—With use, glass fibers may become entrapped in the rubber sleeves and contribute to low breaking force values. Replace rubber sleeves when test values tend to be different from normal for the material under test.

13.1.3 *Procedure*—Place the sample cord package on a suitable unwinding spindle located to the right of the drum clamps. Unwind and discard enough yarn or cord from the package to ensure that undamaged yarn or cord is being tested. If there is any question that the cord has been damaged during conditioning or in subsequent handling, discard. Grasp the loose cord end and secure it in the spring clip on the left drum with the loose end hanging out the left side of the clip. Wrap the cord three times around the drum in a clockwise manner. Try to keep the cord wraps parallel to the front of the drum and parallel to each other. Do not cross the cord. Extend the cord over the right drum and wrap clockwise three times in a similar manner as the left drum. Keep the cord taut when wrapping. Then, secure the cord on the front of the right drum with the spring clip. Do not touch with the bare hand that portion of the specimen that will be between the drums. Handle in such a manner that no change in twist can occur prior to securing to the drums. Use more wraps if necessary to prevent the cord from slipping out of the clips during the test. If in handling, the cord sample is kinked, scraped, untwisted or otherwise damaged, discard the specimen. Operate the testing machine at the specified rate. When the specimen breaks, read the breaking force to the nearest 0.5 N (0.1 lbf) from the recording chart, dial, or by electronic means.

13.1.4 Calculation

13.1.4.1 Calculate the breaking force of individual specimens to the nearest 0.5 N (0.1 lbf) using Eq 1:

$$B = F/2 \tag{1}$$

where:

- B = breaking force, N (lbf), and
- F = observed breaking force, N (lbf).

13.1.4.2 Calculate the average breaking strength for the lot to the nearest 0.5 N (0.1 lbf).

13.1.5 Report

13.1.5.1 State that the specimens were tested as directed in

Section 13.1, Option 1, of Test Methods D 2970. Describe the material(s) or product(s) sampled and the method of sampling used.

13.1.5.2 Report the number of specimens tested and the breaking strength for the lot.

13.1.6 *Precision and Bias*—See Sections 25-27.

13.2 *Option 2, Pneumatic Clamps*:

13.2.1 *Procedure*—Determine the breaking force of five individual specimens as directed in the breaking strength procedure described in Test Methods D 885.

13.2.1.1 Because of the tendency of glass cords and yarns to break at the nips or on the snubbing surfaces, it is necessary to keep the clamp surfaces in good condition. Frequent cleaning with a solvent, and polishing are recommended. In some cases it has been found helpful to use jaw liners made from vinyl or leather strips, or to apply rosin or soap-stone to the ends of the specimen before they are inserted in the clamps. Clamp faces coated with urethane have been used satisfactorily to minimize slippage and jaw breaks.

13.2.2 *Report*

13.2.2.1 State that the specimens were tested as directed in Section 13.2, Option 2, of Test Methods D 2970. Describe the material(s) or product(s) sampled and the method of sampling used.

13.2.2.2 Report the number of specimens tested and the breaking strength for the lot.

13.2.3 *Precision and Bias*—See Sections 25-27.

14. Breaking Tenacity of Conditioned Yarns and Cords

14.1 *Calculation*

14.1.1 Calculate the breaking tenacity of the lot to the nearest 10 mN/tex (0.1 gf/den), from the average breaking force and the average yarn number of the dipped glass (as determined in Section 19) using Eq 2:

$$BT = [S \times (P + 100) / LD] \times 100 \quad (2)$$

where:

BT = breaking tenacity, mN/tex (gf/den),

S = average breaking force of the conditioned specimens, N (gf),

LD = average yarn number of the conditioned specimens, tex (denier), and

P = dip pickup, %, (see Section 23).

14.2 *Report*

14.2.1 State that the specimens were tested as directed in Section 14 of Test Methods D 2970. Describe the material(s) or product(s) sampled and the method of sampling used.

14.2.2 Report the number of specimens tested and the breaking tenacity for the lot.

15. Elongation at Break of Conditioned Yarns and Cords

15.1 Determine the elongation at break of the conditioned glass yarns and cords as directed in the corresponding section of Test Methods D 885.

15.2 *Calculation*

15.2.1 Calculate the observed elongation of each specimen to the nearest 0.1 % based on its nominal gage length.

15.2.2 Calculate the average elongation for the lot to the nearest 0.1 %.

15.3 *Report*

15.3.1 State that the specimens were tested as directed in Section 15 of Test Methods D 2970. Describe the material(s) or product(s) sampled and the method of sampling used.

15.3.2 Report the number of specimens tested and the elongation at break for the lot.

15.4 *Precision and Bias*—See Sections 25-27.

16. Initial Modulus of Conditioned Yarns and Cords

16.1 Determine the initial modulus of the conditioned glass yarns and cords as directed in the corresponding section of Test Methods D 885.

16.2 *Calculation*

16.2.1 Calculate the initial modulus of each specimen to the nearest 10 mN/tex (0.1 gf/den) using Eq 3:

$$M_i = [B \times (P + 100)] / (E \times LD) \quad (3)$$

where:

M_i = initial modulus, mN/tex (gf/den),

B = average breaking force of the conditioned specimens, mN (gf),

P = dip pickup, % (see Section 23),

E = breaking elongation obtained by extrapolation of the tangent of the initial portion of the force-extension curve to the force axis, %, and

LD = average yarn number of the conditioned specimens, tex (denier).

16.2.2 Calculate the average initial modulus for the lot to the nearest 10 mN/tex (0.1 gf/den).

16.3 *Report*

16.3.1 State that the specimens were tested as directed in Section 16 of Test Methods D 2970. Describe the material(s) or product(s) sampled and the method of sampling used.

16.3.2 Report the number of specimens tested and the initial modulus for the lot.

16.4 *Precision and Bias*—See Sections 25-27.

17. Report, Tensile Properties, General

17.1 State that the tensile property tests were made as directed in Test Methods D 2970. Describe the material(s) or product(s) sampled and the method of sampling used.

17.2 Report the following information:

17.2.1 test option used,

17.2.2 type of clamp used,

17.2.3 air pressure and padding material, if used,

17.2.4 rate of recording chart, if applicable,

17.2.5 the number of specimens tested, and,

17.2.6 Any modifications to this test method.

OTHER PROPERTIES OF GLASS YARNS AND CORDS

18. Construction of Yarns and Cords

18.1 Determine the construction of yarn or cord as directed in Specification D 578, except condition the cords in the atmosphere for testing tire cords and industrial yarns.

19. Yarn Number of Dipped Yarns and Cords

19.1 *Procedure*—Determine the yarn number of both yarns and cords in tex (yd/lb) as directed in Specification D 578 test

method for yarn number, except do not dry the specimen in a muffle furnace.

20. Twist in Yarns and Cords

20.1 Determine the twist in single yarn, plied yarn, and tire cord as directed in Test Method D 1423, except use a tension of 10 to 20 mN/tex (0.1 to 0.2 gf/den) on the specimen, based on the yarn number of the yarn or cord. When all but one of the components of the untwisted cord have been cut prior to the determination of the twist of an individual component, leave the total mass unchanged even though the total force applied per unit yarn number in the single component will be higher than in the original plied yarn or cord. Record the length of the single component after all but one of the cord components have been cut from the untwisted cord. Remove the twist from the component and calculate the amount of twist using Eq 6 of Test Method D 1423.

20.1.1 When calculating twist of single yarn or strand component of a cord, use the length of the specimen noted after all but one of the components have been cut from the untwisted cord.

20.1.2 Due to the adhesion of the filaments of resorcinol-formaldehyde-latex (RFL) treated yarns and cords, it is not always feasible to determine accurately the twist in a single component in a plied yarn or cord.

20.2 Report

20.2.1 State that the specimens were tested as directed in Section 20 of Test Methods D 2970. Describe the material(s) or product(s) sampled and the method of sampling used.

20.2.2 Report the number of specimens tested and the twist for the lot.

20.3 *Precision and Bias*—See Sections 25-27.

21. Thickness of Cords

21.1 Determine the thickness of cords as directed in the corresponding section of Test Methods D 885.

22. Count, Width, and Mass of Tire Cord Fabric

22.1 Determine the count, width and mass of the fabric made from glass cord as directed in the sections on these properties of tire cord fabric of Test Methods D 885.

23. Dip Pick-Up (DPU) on Yarns and Cords

23.1 *Scope*—This test method covers the measurement of the amount of resorcinol-formaldehyde-latex (RFL) type adhesive dip pick-up on the yarns and cords.

23.2 *Summary of Test Method*—A specimen is weighed before and after burning off all the dip. The amount of dip on a sample is reported as a percentage based on the mass of the glass-residue after combustion.

23.3 *Significance and Use*—Cords are treated with an adhesive dip to provide for adhesion of elastomers to the cords and to insulate the individual filaments. The amount of dip on the yarns or cords is used for process control.

23.4 Apparatus and Materials:

23.4.1 *Yarn Skein Reel.*

23.4.2 *Analytical Balance*, having a sensitivity of 0.001 g.

23.4.3 *Porcelain Crucible*, Coors No. E-7, or equivalent.

23.4.4 *Muffle Furnace*, that can be maintained at a temperature of $625 \pm 25^\circ\text{C}$ ($1160 \pm 45^\circ\text{F}$).

23.4.5 *Desiccator*, with desiccant.

23.5 Hazards

23.5.1 Because the products of combustion of the RFL dip are toxic vapors, they must be absorbed in a suitable collecting solution or in some other equally reliable safe manner.

23.5.2 Use extreme care when working with the burning of RFL dip.

23.5.3 Wear heat resistant gloves and goggles when working with a muffle furnace.

23.6 Procedure

23.6.1 Wind an approximately 10 g skein from each laboratory sampling unit. Weigh each specimen and record their masses to the nearest 1 mg.

23.6.2 Insert each specimen into a tared crucible and place the crucibles in a muffle furnace at $625 \pm 25^\circ\text{C}$ ($1160 \pm 45^\circ\text{F}$). Maintain this temperature until all the adhesive dip is burned off.

23.6.3 Remove the crucibles from the hot muffle and cool in a desiccator.

23.6.4 Weigh each crucible with the specimen residue to the nearest 1 mg and record the masses.

23.7 Calculation

23.7.1 Determine each specimen's residue mass as the difference between the masses of the crucible with the residue and the crucible tare.

23.7.2 Calculate the DPU for each specimen, to the nearest 0.1 %, using Eq 4:

$$\text{DPU} = (\text{W} - \text{R}) / \text{R} \times 100 \quad (4)$$

where:

DPU = dip pick-up, %,

W = mass of original specimen, g, and

R = mass of specimen residue, g.

23.7.3 Calculate the average DPU for the lot to the nearest 0.1 %.

23.8 Report

23.8.1 State that the specimens were tested as directed in Section 23 of Test Methods D 2970. Describe the material(s) or product(s) sampled and the method of sampling used.

23.8.2 Report the number of specimens tested and the dip pick-up for the lot.

23.9 *Precision and Bias*—See Sections 25-27.

24. Adhesion of Cords to Elastomers

24.1 Determine the adhesion of tire cord to elastomers as directed in Test Method D 4393, except prepared specimens are heated for 30 min at $120 \pm 2^\circ\text{C}$ ($250 \pm 3^\circ\text{F}$).

PRECISION AND BIAS

25. Summary

25.1 In comparing the average values, the differences should not exceed the critical differences for the material and property stated in Table 1 (Table 2) with respect to the number of observations in the average. In 95 out of 100 cases when all of the observations are taken by the same well trained operator using the same piece of test equipment and randomly drawn from the same sample of material, the component of variance for each material and property expressed as standard deviations

TABLE 1 Critical Differences, Units as Indicated^{A,B}

NOTE 1—The data in this table was obtained by measurement in English (inch-pound) units and then mathematically converted.

Name of Property	Number of Observations in Each Average	Single-Operator Precision		Within-Laboratory Precision		Between-Laboratory Precision	
		H15 1/0	H15 3/0	H15 1/0	H15 3/0	H15 1/0	H15 3/0
Breaking Strength, N	1	18.7	60.9	19.1	82.3	36.9	112.1
Pneumatic Clamps	3	10.7	35.1	11.6	65.8	33.8	100.5
	5	8.4	27.1	9.3	61.8	33.4	97.9
	10	5.8	19.1	7.1	58.7	32.5	96.1
Drum Clamps	1	33.8	68.5	33.8	68.5	48.5	81.4
	3	19.6	39.6	19.6	39.6	40.0	59.2
	5	15.1	30.7	15.1	30.7	37.8	53.8
	10	10.7	21.8	10.7	21.8	36.5	49.4
Elongation at Break, %	1	0.35	0.50	0.45	0.67	1.62	3.16
Pneumatic Clamps	3	0.20	0.29	0.36	0.53	1.59	3.13
	5	0.16	0.23	0.33	0.50	1.59	3.13
	10	0.11	0.16	0.31	0.47	1.58	3.12
Modulus, mN/tex	1	1440	1350	1820	2135	9980	11390
Pneumatic Clamps	3	830	785	1385	2235	9890	11300
	5	645	610	1290	2170	9890	11300
	10	460	430	1200	2135	9890	11300
Thickness, mils	1	48	68	64	84	68	99
	3	28	38	48	64	56	81
	5	20	30	46	58	53	79
	10	15	20	43	56	51	76
Twist, tpm	1	9	6	9	7	12	7
	3	6	3	6	5	10	6
	5	4	2	4	4	9	5
	10	3	2	3	4	9	5
Yarn Number, kilotex	1	21	99	21	83	16	83
	3	35	165	35	165	21	165
	5	45	248	45	165	23	165
	10	62	248	62	248	24	248
Dip Pick-up, %	1	0.88	2.3	0.88	2.3	1.16	2.3
	3	0.51	1.3	0.51	1.3	0.91	1.3
	5	0.39	1.0	0.39	1.0	0.85	1.0
	10	0.28	0.7	0.25	0.7	0.81	0.7

^A For the components of variance reported in Table 1, two averages of observed value should be considered significantly different at the 95 % probability level if the difference equals or exceeds the critical differences listed in Table 1.

^B The critical differences listed in Table 1 were calculated using $t = 1.960$ that is based on infinite degrees of freedom.

are listed in Table 3 (Table 4). Larger differences are likely to occur under all other circumstances.

26. Interlaboratory Test Data⁴

26.1 An interlaboratory test was carried out in 1981 for breaking strength by the drum clamp option. One package from each of two materials was selected at random.

26.2 A second laboratory test was carried out in 1981 for breaking strength by the pneumatic clamp option, elongation at break, modulus, twist, thickness, yarn number, and dip pickup. Two packages from each of two materials were selected at random from a production lot and tested in five laboratories for each property. Each laboratory used two operators each of whom tested the number of specimens listed in Table 3 (Table 4) from each material at different times. The total number of

laboratories in the interlaboratory test was seven. However, due to pneumatic clamp limitations in some of the laboratories, only data from five laboratories were available on any given property. The components of variance expressed as standard deviations are listed in Table 3 (Table 4).

27. Bias

27.1 The procedures in these test methods for measuring breaking strength, elongation, twist, thickness, yarn number, and dip pickup have no bias because the values of those properties can be defined only in terms of a test method.

27.2 Interlaboratory testing indicated a bias between laboratories for modulus values, related to differences in individual laboratory selection of the force-extension curve slope. Before a meaningful statement can be made about two specific laboratories performing modulus tests, the amount of statistical bias, if any, between them must be established with each comparison being based on recent data obtained on specimens taken from a lot of material of the type being evaluated so as to be as nearly homogeneous as possible and then randomly assigned to equal numbers to each of the laboratories.

⁴ Supporting data are available from ASTM Headquarters. Request RR:D13-1089. from a production lot and tested in each of five laboratories. Each package was sent to each laboratory, in turn, where two operators each tested ten test specimens of each material at different times. The components of variance expressed as standard deviations are listed in Table 3 (Table 4).

TABLE 2 Critical Differences, Units as Indicated^{A,B}

Name of Property	Number of Observations in Each Average	Single-Operator Precision		Within-Laboratory Precision		Between-Laboratory Precision	
		H15 1/0	H15 3/0	H15 1/0	H15 3/0	H15 1/0	H15 3/0
Breaking Strength, lbf	1	4.2	13.7	4.3	18.5	8.3	25.2
Pneumatic Clamps	3	2.4	7.9	2.6	14.8	7.6	22.6
	5	1.9	6.1	2.1	13.9	7.5	22.0
	10	1.3	4.3	1.6	13.2	7.3	21.6
Drum Clamps	1	7.6	15.4	7.6	15.4	10.9	18.3
	3	4.4	8.9	4.4	8.9	9.0	13.3
	5	3.4	6.9	3.4	6.9	8.5	12.1
	10	2.4	4.9	2.4	4.9	8.2	11.1
Elongation at Break, %	1	0.35	0.50	0.45	0.67	1.62	3.16
Pneumatic Clamps	3	0.20	0.29	0.36	0.53	1.59	3.13
	5	0.16	0.23	0.33	0.50	1.59	3.13
	10	0.11	0.16	0.31	0.47	1.58	3.12
Modulus, gf/den	1	16.3	15.3	20.6	24.2	113	129
Pneumatic Clamps	3	9.4	8.9	15.7	25.3	112	128
	5	7.3	6.9	14.6	24.6	112	128
	10	5.2	4.9	13.6	24.2	112	128
Thickness, mils	1	1.9	2.7	2.5	3.3	2.7	3.9
	3	1.1	1.5	1.9	2.5	2.2	3.2
	5	0.8	1.2	1.8	2.3	2.1	3.1
	10	0.6	0.8	1.7	2.2	2.0	3.0
Twist, tpi	1	0.24	0.15	0.24	0.17	0.31	0.18
	3	0.14	0.08	0.14	0.12	0.25	0.14
	5	0.11	0.06	0.11	0.11	0.23	0.13
	10	0.07	0.05	0.08	0.10	0.22	0.12
Yarn Number, yd/lb	1	24	5	24	6	31	6
	3	14	3	14	3	24	3
	5	11	2	11	3	22	3
	10	8	2	8	2	21	2
Dip Pick-up, %	1	0.88	2.3	0.88	2.3	1.16	2.3
	3	0.51	1.3	0.51	1.3	0.91	1.3
	5	0.39	1.0	0.39	1.0	0.85	1.0
	10	0.28	0.7	0.25	0.7	0.81	0.7

^A For the components of variance reported in Table 2, two averages of observed value should be considered significantly different at the 95 % probability level if the difference equals or exceeds the critical differences listed in Table 2.

^B The critical differences listed in Table 2 were calculated using $t = 1.960$ that is based on infinite degrees of freedom.

28. Keywords

28.1 catenary length; dip pick-up; fabric; glass; glass fibers; industrial yarn; tensile properties/tests; tire cord

APPENDIX

(Nonmandatory Information)

X1. CATENARY LENGTH OF CORDS

X1.1 *Scope*—This appendix covers the determination of the catenary length of glass cords using a twist tester.

X1.2 *Summary of Test Method*—The maximum difference in length of the components of plied yarn or cord is measured after the specimen has been untwisted, and is calculated as a percentage of the original twisted length of the cord.

X1.3 *Significance and Use*—Cords have their maximum physical properties when all components are of equal lengths in the cord: a difference in the length of the components of a plied

yarn or cord indicates a difference in the tension applied to the components during twisting.

X1.4 *Apparatus*—Twist Tester, as described in the Apparatus Section of Test Method D 1423.

X1.5 *Procedure*:

X1.5.1 Place the twist tester on one end of a flat surface bench that will accommodate a minimum specimen length of 250 mm (10 in.). Fasten the specimen in the rotatable clamp and pass it through the movable clamp. Apply a tension of 170

TABLE 3 Standard Deviations, Units as Indicated^A

NOTE 1—The data in this table was obtained by measurement in English (inch-pound) units and then mathematically converted.

Components of Variance Single Material Comparison Name of Property	Number of Tests per Package	Single-Operator Component	Within-Laboratory Component	Between-Laboratory Component
Breaking Strength, N				
Pneumatic Clamps				
15's 1/0	10	6.7	1.3	11.6
15's 3/0	10	22.0	20.2	27.6
Drum Clamps				
15's 1/0	10	12	0.00	12.6
15's 3/0	10	24	0.00	16.1
Elongation at Break, %				
Pneumatic Clamps				
15's 1/0	10	0.126	0.106	0.56
15's 3/0	10	0.182	0.162	1.11
Modulus, mN/tex				
Pneumatic Clamps				
15's 1/0	10	520	400	3540
15's 3/0	10	490	755	4000
Thickness, mils				
15's 1/0	10	18	15	10
15's 3/0	10	25	18	18
Twist, tpm				
15's 1/0	5	3	0.5	3
15's 3/0	5	2	1	1
Yarn Number, kilotex				
15's 1/0	3	56	0.00	71
15's 3/0	3	253	1210	0
Dip Pick-up, %				
15's 1/0	3	0.316	0.00	0.2732
15's 3/0	3	0.815	0.00	0.00

^A The square roots of the components of variance are being reported to express the variability in the appropriate unit of measure rather than as the squares of those units of measure.

g (6 oz) mass to the specimen and tighten the movable clamp. Cut the specimen free, leaving less than 25 mm (1 in.) of the specimen protruding from each clamp.

X1.5.2 Read and record the original gage length to the nearest 0.5 mm (0.005 in.).

X1.5.3 Untwist the cord specimen as directed in 20.1. Allow the untwisted specimen to rest for 10 s and read the gage length (shortest ply length) to the nearest 0.5 mm (0.05 in.).

X1.5.4 Cut the tightest end, and allow the specimen to rest for an additional 10 s.

X1.5.5 Repeat the operation as directed in X1.5.4 until only one ply remains uncut. Read the gage length (longest ply length) to the nearest 0.5 mm (0.05 in.).

X1.6 Calculation

X1.6.1 Calculate the catenary length to the nearest 0.1 mm (0.01 in.), using Eq X1.1:

$$CL = (L - S)/U \times 100 \quad (X1.1)$$

TABLE 4 Standard Deviations, Units as Indicated^A

Components of Variance Single Material Comparison Name of Property	Number of Tests per Package	Single-Operator Component	Within-Laboratory Component	Between-Laboratory Component
Breaking Strength, lbf				
Pneumatic Clamps				
15's 1/0	10	1.51	0.30	2.59
15's 3/0	10	4.94	4.51	6.16
Drum Clamps				
15's 1/0	10	2.76	0.00	2.82
15's 3/0	10	5.55	0.00	3.59
Elongation at Break, %				
Pneumatic Clamps				
15's 1/0	10	0.126	0.106	0.56
15's 3/0	10	0.182	0.162	1.11
Modulus, gf/den				
Pneumatic Clamps				
15's 1/0	10	5.88	4.55	40.1
15's 3/0	10	5.53	8.54	45.3
Thickness, mils				
15's 1/0	10	0.7	0.6	0.4
15's 3/0	10	1.0	0.7	0.7
Twist, tpi				
15's 1/0	5	0.085	0.013	0.073
15's 3/0	5	0.052	0.031	0.023
Yarn Number, yd/lb				
15's 1/0	3	8.84	0.00	6.99
15's 3/0	3	1.96	0.41	0.00
Dip Pick-up, %				
15's 1/0	3	0.316	0.00	0.2732
15's 3/0	3	0.815	0.00	0.00

^A The square roots of the components of variance are being reported to express the variability in the appropriate unit of measure rather than as the squares of those units of measure.

where:

- CL = catenary length, %,
- L = longest ply length, mm (in.),
- S = shortest ply length, mm (in.), and
- U = original length of cord specimen in tester, before untwisting, mm (in.).

X1.7 Report

X1.7.1 State that the specimens were tested as directed in Appendix X1 of Test Methods D 2970. Describe the material(s) or product(s) sampled and the method of sampling used.

X1.7.2 Report the number of specimens tested and the catenary length for the lot.

X1.8 Precision and Bias

X1.8.1 Limited interlaboratory testing for catenary showed between laboratory coefficients of variation unexpectedly high (above 50 %) and was not included in this study because only two laboratories provided data. Because between laboratory precision is known to be poor, comparative catenary tests as directed in Section 5.1.1 may be needed for acceptance testing of commercial shipments of industrial yarns or cords.



D 2970

ASTM International takes no position respecting the validity of any patent rights asserted in connection with any item mentioned in this standard. Users of this standard are expressly advised that determination of the validity of any such patent rights, and the risk of infringement of such rights, are entirely their own responsibility.

This standard is subject to revision at any time by the responsible technical committee and must be reviewed every five years and if not revised, either reapproved or withdrawn. Your comments are invited either for revision of this standard or for additional standards and should be addressed to ASTM International Headquarters. Your comments will receive careful consideration at a meeting of the responsible technical committee, which you may attend. If you feel that your comments have not received a fair hearing you should make your views known to the ASTM Committee on Standards, at the address shown below.

This standard is copyrighted by ASTM International, 100 Barr Harbor Drive, PO Box C700, West Conshohocken, PA 19428-2959, United States. Individual reprints (single or multiple copies) of this standard may be obtained by contacting ASTM at the above address or at 610-832-9585 (phone), 610-832-9555 (fax), or service@astm.org (e-mail); or through the ASTM website (www.astm.org).