



Designation: D 3217 – 01a

## Standard Test Methods for Breaking Tenacity of Manufactured Textile Fibers in Loop or Knot Configurations<sup>1</sup>

This standard is issued under the fixed designation D 3217; the number immediately following the designation indicates the year of original adoption or, in the case of revision, the year of last revision. A number in parentheses indicates the year of last reapproval. A superscript epsilon (ε) indicates an editorial change since the last revision or reapproval.

### 1. Scope

1.1 These test methods cover the measurement of the breaking tenacity of manufactured textile fibers taken from filament yarns, staple, or tow fiber, either crimped or uncrimped, and tested in either a double loop or as a strand formed into a single overhand knot.

1.2 Methods for measuring the breaking tenacity of conditioned and wet (immersed) fibers in loop and knot form are included.

1.3 Elongation in loop or knot tests has no known significance, and is usually not recorded.

1.4 The basic distinction between the procedures described in these test methods and those included in Test Methods D 2101 is the configuration of the specimen, that is, either as a double loop or in the configuration of a single overhand knot.

1.5 *This standard does not purport to address all of the safety concerns, if any, associated with its use. It is the responsibility of the user of this standard to establish appropriate safety and health practices and determine the applicability of regulatory limitations prior to use.*

### 2. Referenced Documents

2.1 *ASTM Standards:*

---

<sup>1</sup> These test methods are under the jurisdiction of ASTM Committee D13 on Textiles and are the direct responsibility of Subcommittee D13.58 on Yarn and Fiber Test Methods.

Current edition approved ~~May~~ September 10, 2000<sup>1</sup>. Published ~~May~~ November 2001. Originally published as D 3217 – 73 T. Last previous edition D 3217 – 95<sup>01</sup>.

- D 76 Specification for Tensile Testing Machines for Textiles<sup>2</sup>
- D 123 Terminology Relating to Textiles<sup>2</sup>
- D 1577 Test Methods for Linear Density of Textile Fibers<sup>2</sup>
- D 1776 Practice for Conditioning and Testing Textiles<sup>2</sup>
- D 2258 Practice for Sampling Yarn for Testing<sup>2</sup>
- D 3333 Practice for Sampling ~~Man-Made~~ **Manufactured** Staple Fibers, Sliver, or Tow for Testing<sup>3</sup>
- D 3822 Test Method for Tensile Properties of Single Textile Fibers<sup>3</sup>
- D 4848 Terminology of Force, Deformation, and Related Properties of Textiles<sup>3</sup>

### 3. Terminology

#### 3.1 Definitions:

3.1.1 *breaking force, n*—the maximum force applied to a material carried to rupture.

3.1.1.1 *Discussion*—Force is commonly expressed in grams-force (gf), kilograms-force (kgf), pounds-force (lbf), newtons (N), or millinewtons (mN).

3.1.2 *breaking tenacity, n*—the tenacity at the breaking force.

3.1.2.1 *Discussion*—Breaking tenacity is commonly expressed as grams-force per tex (gf/tex), grams-force per denier (gf/den), millinewtons per tex (mN/tex), or grams-force per denier (gf/den). Millinewtons are numerically equal to grams-force times 9.81.

3.1.2.2 *Discussion*—The breaking tenacity is calculated from the breaking force and the linear density of the unstrained specimen, or obtained directly from tensile testing machines which can be suitably adjusted to indicate tenacity instead of breaking force, for specimens of known linear density.

3.1.3 *linear density, n<sub>for fiber and yarn</sub>*,—mass per unit length.

3.1.3.1 *Discussion*—The preferred units of measurement are grams and metres, or multiples or submultiples of these. The tex unit, grams per kilometre, is recommended for yarns.

3.1.4 *manufactured staple fiber, n*—fiber of spinnable length manufactured directly or by cutting filaments.

3.1.4.1 *Discussion*—Man-made staple fiber does not include cut waste.

3.1.5 *tenacity, n*—*in a tensile test*, the force exerted on the specimen based on the linear density of the unstrained material.

3.1.5.1 *Discussion*—Tenacity is commonly expressed as grams-force per tex (gf/tex), grams-force per denier (gf/den), millinewtons per tex (mN/tex), or grams-force per denier (gf/den).

3.1.6 For definitions of other textile terms used in these test methods, refer to Terminology D 123. For definitions of other terms related to force and deformation in textiles, refer to Terminology D 4848.

### 4. Summary of Test Methods

4.1 Single-fiber specimens in the form of a loop as described in 9.4.1 are broken on a constant-rate-of-extension type testing machine at a predetermined rate of elongation and the breaking force is determined.

4.2 Single-fiber specimens in the form of a knot as described in 9.4.2 are broken on a constant-rate-of-extension type testing machine at a predetermined rate of elongation, and the breaking force is determined.

4.3 The breaking tenacity is calculated from the breaking force registered on the force-elongation curve and the previously determined linear density.

### 5. Significance and Use

5.1 Both the loop breaking tenacity and the knot breaking tenacity, calculated from the breaking force measured under the conditions specified herein and the linear density of the fiber, are fundamental properties that are used to establish limitations on fiber-processing and upon their end-use applications. Physical properties, such as brittleness, not well defined by tests for breaking force and elongation can be estimated from the ratio of breaking tenacity measured in loop or knot tests, or both, and the normal tenacity as measured by Test Method D 3822.

5.2 This test method is not recommended for acceptance testing of commercial shipments in the absence of reliable information on between-laboratory precision (see Note 3). In some cases the purchaser and the supplier may have to test a commercial shipment of one or more specific materials by the best available method, even though the method has not been recommended for acceptance testing of commercial shipments. In such a case, if there is a disagreement arising from differences in values reported by the purchaser and the supplier when using this test method for acceptance testing, the statistical bias, if any, between the laboratory of the purchaser and the laboratory of the supplier should be determined with each comparison being based on testing specimens randomly drawn from one sample of material of the type being evaluated.

### 6. Apparatus and Reagents

6.1 *Tensile Testing Machine*, conforming to Specification D 76 for Constant-Rate-of-Specimen-Extension-(CRE) type machines, having a full-scale capacity ranging from 2 to 100 g and equipped with provisions for breaking fibers immersed in a liquid if such tests on a wet specimen are desired.

<sup>2</sup> Annual Book of ASTM Standards, Vol 07.01.

<sup>3</sup> Annual Book of ASTM Standards, Vol 07.02.

- 6.2 *Clamps*, with flat jaws for gripping the fiber specimens designed to minimize slippage in the clamps during the tests, or
- 6.2.1 *Tabs*, of thin plastic or other material for use with cementing techniques, and
- 6.2.2 *Cement or Adhesive*—The adhesive must bind the tab to the fiber without affecting an appreciable solution of the latter or any change in the moisture content of the specimen.
- 6.3 *Wetting Agent* (0.1 % solution)—Use a nonionic aqueous solution.
- 6.4 *Jig*, to aid in accurately mounting specimens on tabs at the specified gage length.

## 7. Sampling

7.1 *Lot Sampling*—As a lot sample for acceptance testing, take at random the number of shipping containers directed in the applicable material specification or other agreement between the purchaser and the supplier, such as an agreement to use Practice D 3333 or Practice D 2258. Consider shipping containers to be the primary sampling units.

NOTE 1—An adequate specification or other agreement between the purchaser or the supplier requires taking into account the variability between shipping units, between packages, ends, or other laboratory sampling unit within a shipping unit if applicable, and within specimens from a single package, end, or other laboratory sampling unit to provide a sampling plan with a meaningful producer's risk, consumer's risk, acceptable quality level, and limiting quantity level.

7.2 *Laboratory Sample*—As a laboratory sample for acceptance testing, take at random from each shipping container in the lot sample the number of laboratory sampling units as directed in an applicable material specification or other agreement between the purchaser and the supplier such as an agreement to use Practice D 3333 or Practice D 2258. Preferably, the same number of laboratory sampling units are taken from each shipping container in the lot sample. If differing numbers of laboratory sampling units are to be taken from shipping containers in the lot sample, determine at random which shipping containers are to have each number of laboratory units drawn.

7.2.1 *For Staple Fiber*—Take 50-g samples from laboratory sampling units.

7.2.2 *For Sliver (or Top) or Tow*—Take 1 m from the leading end which has a clean, uniform appearance.

7.2.3 *For Yarns*—Prepare at least a 50-m skein from each package.

7.3 *Test Specimens*—From each laboratory sampling unit, take ten specimens at random. If the standard deviation determined for the ten specimens is more than a value agreed upon between the purchaser and the supplier, continue testing in groups of ten specimens from the same laboratory sampling unit in the container until the standard deviation for all specimens tested is not more than the agreed to value or, by agreement, stop testing after a specified number.

7.3.1 Carefully remove twist before taking specimens from yarn. Using tweezers and grasping the specimens at the ends, gently remove the required number of specimens from the laboratory sampling units for testing. In some cases, if specimens are not to be tested immediately, place them on an identified short-pile of plush surface for storage until ready to test.

## 8. Conditioning

8.1 Precondition and condition the specimens, as directed in Practice D 1776.

8.1.1 Specimens that are to be tested wet need not be preconditioned or conditioned.

## 9. Procedure

9.1 *Test Conditions:*

9.1.1 *Standard*—Test the adequately conditioned fibers in the standard atmosphere for testing textiles which is  $70 \pm 2^\circ\text{F}$  ( $21 \pm 1^\circ\text{C}$ ) and  $65 \pm 2\%$  relative humidity.

9.1.2 *Wet*—Immerse the specimens in a 0.1 % solution of a nonionic wetting agent for a minimum of 2 min before testing. To save time in the tensile testing machine, specimens whose moduli are not affected by moisture may be immersed in separate container of solution while other specimens are being broken.

9.2 Measure and record the individual linear densities of the fibers to be tested as directed in the vibroscope procedure of Test Methods D 1577. Linear density of fibers for wet testing must be determined before exposure to wetting bath.

9.3 Set the gage length for a distance of 1 in. (25.4 mm) between the clamps.

9.3.1 When tabs are cemented on the ends of the specimens, the specimen gage length shall be 1 in. (25.4 mm).

9.4 *Preparation and Mounting of Specimens:*

9.4.1 *Loop*—Form a double loop using two fiber specimens as shown in Fig. 1. Form a loop in Fiber A. Mount the ends of the loop, close together, in one of the clamps. Thread one end of Fiber B through the loop formed in Fiber A. Mount both ends of Fiber B, close together, in the other clamp removing slack without stretching the fibers. The intersection of the two fibers should be midway between the clamps.

9.4.2 *Knot*—Form a single overhand knot in a fiber specimen as shown in Fig. 2. Mount the specimen with one end in each of the clamps, removing slack without stretching the fiber. The knot should be located midway between the clamps. Tabs may be attached to the fibers to assist in holding the specimens. If tabs are used, they define the nominal gage length of the fiber specimen and are best located with the aid of a jig. Be sure that the fiber specimen is centered in the clamp, that the clamps are aligned, and that there is no lateral motion of either clamp.

9.5 Operate the testing machine so that the breaking force falls in a range from 20 to 80 % of full-scale capacity, and at a rate of extension of 100 % of the nominal gage length per minute (60 % per minute may be used for experimental purposes without

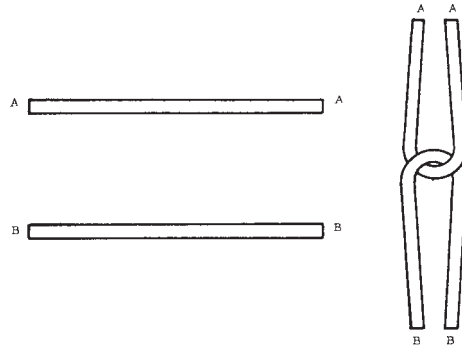

FIG. 1 Loop Specimen Configuration

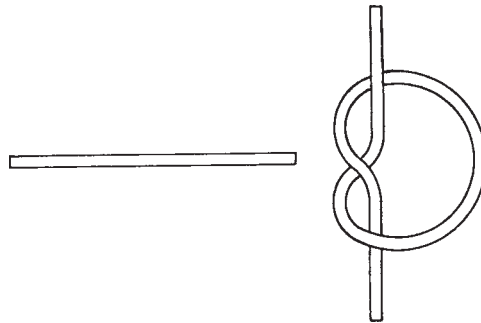

FIG. 2 Knot Specimen Configuration

any significant effect upon the observed breaking force of the test specimen). Start the machine and extend the specimen to the rupture point.

9.5.1 Record which of the fibers in the looped pair breaks, if only one fiber breaks.

9.5.2 If more than 5 % of the total number of fibers tested break within 5 mm of the clamps, check the clamping mechanism for defects that might cause fiber damage.

9.6 Measure straight breaking tenacity as specified in Test Method D 3822 using a 1-in. (25.4-mm) gage length and 100 % rate of extension, if requested.

**10. Calculation**

10.1 *Loop Breaking Tenacity*—Calculate the loop breaking tenacity of the individual specimens, expressed in grams-force per tex or millinewtons per tex, using Eq 1:

$$\text{Loop breaking tenacity, gf/tex} = M/2L \tag{1}$$

where:

$M$  = breaking force, gf, and

$L$  = linear density of the specific specimen that broke during the test, tex.

If both fibers break use the average tex.

NOTE 2—Millinewtons per tex equal grams-force per tex times 9.81. Grams-force per denier or millinewtons per denier may be calculated by using denier rather than tex as the linear density of the specimens.

10.1.1 Calculate the average loop breaking tenacity of all specimens tested.

10.1.2 Calculate the standard deviation or coefficient of variation, or both, if requested.

10.2 *Knot Breaking Tenacity*—Calculate the knot breaking tenacity of the individual specimens, in grams-force per tex or in millinewtons per tex, using Eq 2 (Note 2):

$$\text{Knot breaking tenacity, gf/tex} = M/L \tag{2}$$

where:

$M$  = breaking force, gf, and

$L$  = linear density of the specimen, tex.

10.2.1 Calculate the average knot breaking tenacity of all specimens tested.

10.2.2 Calculate the standard deviation or coefficient, or both, if requested.

10.3 *Straight Breaking Tenacity*—Calculate the straight breaking tenacity of the individual specimens as directed in Test Methods D 2101, if requested.

- 10.3.1 Calculate the average straight breaking tenacity of all the specimens tested, if requested.
- 10.3.2 Calculate the standard deviation or the coefficient of variation, or both, if requested.
- 10.4 Calculate the ratio of breaking tenacities of loop to straight configurations, if requested.
- 10.5 Calculate the ratio of breaking tenacities of knot to straight configurations, if requested.

## 11. Report

11.1 State that the specimens were tested as directed in Test Methods D 3217. Describe the material or product sampled and the method of sampling used.

11.2 Report the following information when applicable:

- 11.2.1 Average breaking tenacity, gf/tex or mN/tex,
- 11.2.2 Average loop breaking tenacity, gf/tex or mN/tex,
- 11.2.3 Ratio of breaking tenacities of loop to straight configurations,
- 11.2.4 Average knot breaking tenacity, gf/tex or mN/tex,
- 11.2.5 Ratio of breaking tenacities in knot to straight configurations,
- 11.2.6 Standard deviation or coefficient of variation, or both, for the properties measured,
- 11.2.7 Rate of extension based on the nominal gage length,
- 11.2.8 Nominal gage length used,
- 11.2.9 Make and model of the testing machine used, and
- 11.2.10 Conditions under which the specimens were tested, that is, standard, wet, other.

## 12. Precision and Bias

12.1 *Interlaboratory Test Data*—An interlaboratory test was run in 1969 and 1970 in which samples randomly drawn from three materials were tested in each of four laboratories. Each laboratory used one operator, each of whom tested 50 specimens of each material. The components of variance expressed as coefficients of variation were calculated to be the values in Table 1.

12.2 *Precision*—For the components of variance in Table 2, two averages of observed values should be considered significantly different at the 95 % probability level if the difference equals or exceeds the critical differences tabulated in Table 2.

NOTE 3—Since the interlaboratory tests included only four laboratories, between-laboratory precision data should be used with special caution.

NOTE 4—The tabulated values of the critical differences should be considered to be a general statement, particularly with respect to between-laboratory precision. Before a meaningful statement can be made about two specific laboratories, the amount of statistical bias, if any, between them must be established, with each comparison being based on recent data obtained on randomized specimens from one sample of the material to be tested.

12.3 *Bias*—The value for the breaking tenacity of fibers in loop or knot configurations can be defined only in terms of a specified test method. Within this limitation, Test Methods D 3217 for testing loop and knot configurations has no known bias.

## 13. Keywords

- 13.1 breaking strength; fibers; textile fibers

**TABLE 1 Components of Variance as Coefficients of Variation, Percent of the Average**

Property	Single-Operator Component	Between-Laboratory Component
Loop Breaking Tenacity Nylon 6	6.52	3.10
Loop Breaking Tenacity Polyester	11.9	4.16
Loop Breaking Tenacity Viscose Rayon	8.46	38.8
Knot Breaking Tenacity Nylon 6	6.11	18.7
Knot Breaking Tenacity Polyester	12.2	5.91
Knot Breaking Tenacity Viscose Rayon	19.2	37.4

**TABLE 2 Critical Differences,<sup>A,B</sup> Percent of the Grand Average, for the Conditions Noted**

Property	Number of Observations In Each Average	Single-Operator Precision	Between-Laboratory Precision
Loop Breaking Tenacity Nylon 6	10	5.71	10.3
	20	4.04	9.49
	40	2.86	9.05
	80	2.02	8.83
Loop Breaking Tenacity Polyester	10	10.4	15.6
	20	7.39	13.7
	40	5.22	12.7
	80	3.69	12.1
Loop Breaking Tenacity Viscose Rayon	10	7.41	108
	20	5.24	108
	40	3.71	108
	80	2.62	108
Knot Breaking Tenacity Nylon 6	10	5.35	52.2
	20	3.79	52.0
	40	2.68	52.0
	80	1.89	51.9
Knot Breaking Tenacity Polyester	10	10.7	19.6
	20	7.57	18.0
	40	5.35	17.2
	80	3.79	16.8
Knot Breaking Tenacity Viscose Rayon	10	16.8	105
	20	11.9	104
	40	8.41	104
	80	5.95	104

<sup>A</sup> The critical differences were calculated using  $t = 1.960$ , which is based on infinite degrees of freedom.

<sup>B</sup> To convert the tabulated values of the critical differences to units of measure, multiply the average of the two specific sets of data being compared by the critical differences expressed as decimal fractions.

*ASTM International takes no position respecting the validity of any patent rights asserted in connection with any item mentioned in this standard. Users of this standard are expressly advised that determination of the validity of any such patent rights, and the risk of infringement of such rights, are entirely their own responsibility.*

*This standard is subject to revision at any time by the responsible technical committee and must be reviewed every five years and if not revised, either reapproved or withdrawn. Your comments are invited either for revision of this standard or for additional standards and should be addressed to ASTM International Headquarters. Your comments will receive careful consideration at a meeting of the responsible technical committee, which you may attend. If you feel that your comments have not received a fair hearing you should make your views known to the ASTM Committee on Standards, at the address shown below.*

*This standard is copyrighted by ASTM International, 100 Barr Harbor Drive, PO Box C700, West Conshohocken, PA 19428-2959, United States. Individual reprints (single or multiple copies) of this standard may be obtained by contacting ASTM at the above address or at 610-832-9585 (phone), 610-832-9555 (fax), or service@astm.org (e-mail); or through the ASTM website (www.astm.org).*