



## Standard Test Method for Coefficient of Friction, Yarn to Yarn<sup>1</sup>

This standard is issued under the fixed designation D 3412; the number immediately following the designation indicates the year of original adoption or, in the case of revision, the year of last revision. A number in parentheses indicates the year of last reapproval. A superscript epsilon ( $\epsilon$ ) indicates an editorial change since the last revision or reapproval.

### 1. Scope

1.1 This test method covers the measurement of frictional properties for both continuous filament and spun-staple yarns under boundary friction conditions.

1.2 This test method has been used with yarns having linear densities ranging from 1.5 to 200 tex, but may be used with yarns outside these ranges (15 to 1800 denier).

NOTE 1—For coefficient of friction, yarn to metal, see Test Method D 3108.

1.3 The values stated in SI units are to be regarded as the standard. The inch-pound units given in parentheses are for information only.

1.4 *This standard does not purport to address all of the safety concerns, if any, associated with its use. It is the responsibility of the user of this standard to establish appropriate safety and health practices and determine the applicability of regulatory limitations prior to use.*

### 2. Referenced Documents

#### 2.1 ASTM Standards:

- D 123 Terminology Relating to Textiles<sup>2</sup>
- D 1776 Practice for Conditioning Textiles for Testing<sup>2</sup>
- D 1907 Test Method for Yarn Number by the Skein Method<sup>2</sup>
- D 2258 Practice for Sampling Yarn for Testing<sup>2</sup>
- D 3108 Test Method for Coefficient of Friction, Yarn to Solid Material<sup>2</sup>

### 3. Terminology

#### 3.1 Definitions:

3.1.1 *boundary friction, n*—friction at low sliding speeds (0.02 m/min or less) where lubrication occurs under thin-film lubricant conditions.

3.1.2 *coefficient of friction, n*—the ratio of the tangential force that is needed to maintain uniform relative motion between two contacting surfaces to the perpendicular force holding them in contact.

3.1.3 *friction, n*—the resistance to the relative motion of one

body sliding, rolling, or flowing over another body with which it is in contact.

3.1.4 *radian, n*—the plane angle between two radii of a circle which intersects the circumference of the circle making an arc equal in length to the radius.

3.1.4.1 *Discussion*—A radian is equal to  $180^\circ$  divided by  $\pi$  and is approximately  $57.3^\circ$ .

3.1.5 *stick-slip, n*—a phenomenon occurring when boundary lubrication is deficient, manifested by alternative periods of sticking and slipping of the surfaces in contact.

3.1.5.1 *Discussion*—At the specified sliding speed, in yarn friction testing, stick-slip cycles are long enough that they can be readily recorded. During sticking, the frictional force slowly rises to a peak value, at which the slipping occurs with the frictional force rapidly decreasing to a minimum value.

3.1.6 *wrap angle, n*—in yarn friction testing, the cumulative angular contact of the test specimen against the friction-inducing device, expressed in radians.

3.1.7 For definitions of other textile terms used in this method, refer to Terminology D 123.

### 4. Summary of Test Method

4.1 A length of yarn is moved at a known speed in contact with itself or similar yarn at a specified wrap angle. The input and output tensions are measured and the coefficient of friction calculated. Alternatively, apparatus may be used in which the ratio of input to output tension is measured allowing the coefficient of friction to be indicated directly.

4.2 Two optional procedures are included. Option 1 is based on the Twisted Strand Method, using a wrap angle of 15.71 rad ( $900^\circ$ ). Option 2 is based on the Capstan Method, using a wrap angle of 3.14 radians ( $180^\circ$ ).

NOTE 2—Editions of Test Method D 3412 prior to the 1986 revision incorrectly stated the wrap angle for Option 1 to be 18.85 rad. This is incorrect, since 3 turns of the swivel pulley do not result in a wrap angle of 18.85 radians. This has now been corrected to 15.71 rad. This should be taken into account in comparing with earlier results.

### 5. Significance and Use

5.1 This test method for testing yarn-to-yarn friction is being used, but is not recommended, for acceptance testing of commercial shipments since between-laboratory precision is known to be poor.

5.1.1 In some cases, the purchaser and supplier may have to test a commercial shipment of one or more specific materials

<sup>1</sup> This test method is under the jurisdiction of ASTM Committee D-13 on Textiles and is the direct responsibility of Subcommittee D 13.58 on Yarn Test Methods, General.

Current edition approved May 15, 1995. Published July 1995. Originally published as D 3412 – 75T. Last previous edition D 3412 – 89.

<sup>2</sup> *Annual Book of ASTM Standards*, Vol 07.01.

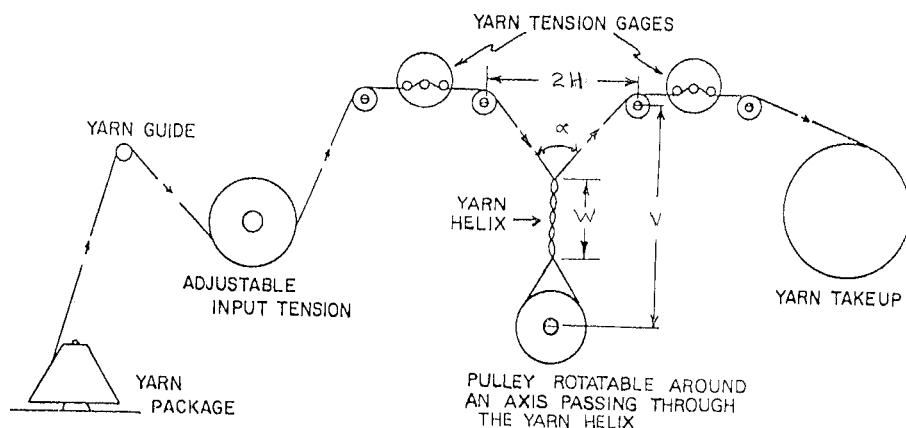

FIG. 1 Twisted Strand Yarn-to-Yarn Friction Apparatus—Twisted-Yarn Method

by the best available method even though the method has not been recommended for acceptance testing of commercial shipments. In case of a dispute arising from differences in reported test results when using Test Method D 3412 for acceptance testing of commercial shipments, the purchaser and the supplier should conduct comparative tests to determine if there is a statistical bias between their laboratories. Competent statistical assistance is recommended for the investigation of bias. As a minimum, the two parties should take a group of test specimens that are as homogeneous as possible and that are from a lot of material of the type in question. The test specimens should then be randomly assigned in equal numbers to each laboratory for testing. The average results from the two laboratories should be compared using Student's *t*-test for unpaired data and an acceptable probability level chosen by the two parties before the testing is begun. If a bias is found, either its cause must be found and corrected or the purchaser and the supplier must agree to interpret future test results with consideration to the known bias.

5.2 This test method is intended for the determination of yarn-to-yarn boundary friction coefficients measured over a specified length of yarn.

5.3 The test method is useful for quality control, research, and the characterization of yarn boundary lubricants.

NOTE 3—Because the geometry of the yarns is different, Options 1 and 2 should not be expected to give the same numerical values on the same yarns.

## 6. Apparatus

6.1 *Option 1 (Twisted Strand Method)*—A schematic diagram of the elements required for twisted strand friction measurement is shown in Fig. 1. The yarn is run over upper pulleys and under a lower pulley and is intertwisted between these pulleys. One end of the yarn (output) is taken up at a controlled rate. The other end of yarn (input) is maintained at a controlled tension. The number of intertwisting wraps, the apex angle between the input and output yarns, and the input and output tensions are precisely known or recorded. From these data the coefficient of yarn-on-yarn friction is calculated. The required elements are:

6.1.1 *Friction Testing Apparatus (Indirect)*<sup>3</sup>—Apparatus in which the input tension is measured, or controlled to a set value, the output tension is measured, and the coefficient of friction is calculated within or outside the apparatus.

6.1.1.1 *Yarn Input Tension Control*—A means of controlling the yarn input tension to the nearest 5% is required. A demand-feed apparatus tensioned with a fixed weight is suitable.

6.1.1.2 *Yarn Input Tension Measurement*—The yarn input tension is measured to within  $\pm 5.0$  mN ( $\pm 0.5$  gf), using a suitable tension gage producing an electrical signal. The signal is recorded as millinewtons (grams-force) or is used in combination with the yarn output tension measured to calculate the coefficient of friction. If a demand-feed apparatus tensioned with a precise, known fixed mass is used, the yarn input tension need not be constantly measured and recorded.

6.1.1.3 *Yarn Output Tension Measurement*—Yarn output tension is measured to within  $\pm 5.0$  mN ( $\pm 0.5$  gf), using a suitable tension gage producing an electrical signal. The signal is recorded as millinewtons, (grams-force), or is used in combination with the yarn input tension setting or measurement to calculate the coefficient of friction.

6.1.2 *Friction Testing Apparatus (Direct)*<sup>4</sup>—Apparatus in which the ratio of output to input tensions are compared directly and the coefficient of friction is indicated on a scale.

6.1.3 *Auxilliary Equipment (Indirect and Direct)*:

6.1.3.1 *Guide Pulley Arrangement*—The upper and lower pulleys shall be of the same diameter. The recommended pulley diameter is 38 mm (1.5 in.). The separation distance between the upper pulleys,  $2H$ , shall be  $140 \pm 2$  mm ( $5.5 \pm 0.1$  in.). The separation distance between the axis of the lower pulley and a line connecting the upper pulley axes,  $V$ , shall be

<sup>3</sup> Equipment meeting these requirements may be obtained commercially from: Custom Scientific Instruments Inc, 13 Wing Drive, Cedar Knolls, NJ 07292, and Rothschild-Messinstruments, Traubstr 3, 8002 Zurich, Switzerland, represented in the U.S. by Lawson Hemphill Sales Inc, PO Drawer 6388, Spartanburg, SC 29304.

<sup>4</sup> Equipment meeting these requirements may be obtained commercially from: Rothschild-Messinstruments, Traubstr 3, 8002 Zurich, Switzerland, represented in the U.S. by Lawson Hemphill Sales Inc, PO Drawer 6388, Spartanburg, SC 29304, and Shirley Developments Ltd, PO Box 6, Didsbury, Manchester M20 8SA, England, represented in the U.S. by Lawson Hemphill Sales Inc, PO Drawer 6388, Spartanburg, SC 29304.

280 ± 2 mm (11 ± 0.1 in.). All pulleys shall be in the same plane. The lower pulley may optionally be mounted so that it can be swiveled around an axis at right angles to its axis of rotation and then fixed in position in the same plane as the upper pulleys.

6.1.3.2 *Drive Unit*—The yarn takeup shall run between 20 and 100 mm/min (0.75 and 4.0 in./min).

6.2 *Option 2 (Capstan Method)*—A schematic diagram of the elements required for the Capstan Method is shown in Fig. 2. Suitable elements are:

6.2.1 *Cylinder*—A rotating mandrel of 50 ± 2 mm (2.0 ± 0.1 in.) outside diameter.

6.2.2 *Drive Unit*—A mechanism designed to rotate the cylinder at a surface speed of 20 ± 1 mm/min (0.75 ± 0.04 in./mm).

6.2.3 *Winding Unit*—A device to wrap the yarn on the surface of the cylinder. A helix angle of 0.2 to 0.3 rad (10 to 15°) is needed to prevent burrowing by the hanging strand of yarn.

6.2.4 *Tension Gage*—A suitable tension gage, producing an electrical signal, to measure the yarn output tension which is recorded as millinewtons or after calculation as coefficient of friction.

6.2.5 *Weights*—A set of weights or other device to preset the input tension.

NOTE 4—Measured stick-slip differentials are greatly dependent on tension transducer spring constants, yarn modulus, and recorder frequency responses. If interlaboratory checks are required, the same type of tension transducer and recorder should be used and the distance between the transducer and the hanging weight to center line of the mandrel must be specified.

## 7. Sampling

7.1 *Lot Sample*—As a lot sample for acceptance testing, take at random the number of shipping containers directed in an applicable material specification or other agreement between the purchaser and the supplier, such as an agreement to use Practice D 2258. Consider shipping containers to be the primary sampling units.

NOTE 5—An adequate specification or other agreement between the purchaser and the supplier requires taking into account the variability

between shipping units, between packages or ends within a shipping unit, and between specimens from a single package so as to provide a sampling plan with a meaningful producer's risk, consumer's risk, acceptable quality level, and limiting quality level.

7.2 *Laboratory Sample*—As a laboratory sample for acceptance testing, take at random from each shipping unit in the lot sample the number of packages or ends directed in an applicable material specification or other agreement between the purchaser and the supplier such as an agreement to use Practice D 2258. Preferably, the same number of packages should be taken from each shipping unit in the lot sample. If differing numbers of packages are to be taken from shipping units in the lot sample, determine at random which shipping units are to have each number of packages drawn.

7.3 *Test Specimens*—Test one specimen from each package in the laboratory sample.

## 8. Conditioning

8.1 *Preparation of Test Packages*—Remove sufficient yarn from the test packages to avoid testing non-representative layers. If in doubt, remove about 10 % of the length of yarn on the package.

8.2 The strand to be tested must have a uniform moisture content along its length. Atmospheric conditions must therefore be stable and the strand must be in equilibrium with the prevailing atmosphere. To satisfy this condition, testing should be carried out after thorough conditioning in the standard atmosphere for testing textiles.

8.3 *Preconditioning*—Precondition packages of yarn for at least 3 h in an atmosphere with a relative humidity between 5 and 25 % and a temperature not exceeding 50°C (121°F).

8.4 *Conditioning*—Condition the preconditioned packages of yarn in the standard atmosphere for testing textiles (relative humidity 65 ± 2 % and temperature 21 ± 1°C (70 ± 2°F)) in moving air until it has reached moisture equilibrium for testing, as directed in Practice D 1776.

## 9. Procedure

9.1 Test all specimens in the standard atmosphere for testing textiles, which is a relative humidity 65 ± 2 % and temperature 21 ± 1°C (70 ± 2°F).

9.2 *Option 1 (Twisted Strand Method)*:

9.2.1 Calibrate the apparatus to the specified full scale reading. Check the freedom of the pulleys by running yarn through the apparatus to determine the difference between input and output tensions with no yarn friction. Designate this value as  $\Delta T$ .

9.2.2 Feed the yarn through the apparatus. If the test apparatus is equipped with a rotating lower pulley, rotate the swivel pulley clockwise through three complete revolutions. Otherwise, remove the yarn from the lower pulley by placing it around fingers, rotate the hand to twist the yarn loop three complete revolutions, and then replace the yarn under the lower pulley. The first half revolution brings the input and output sections of the yarn into contact and corresponds to a wrap angle of zero. The additional two and one-half revolutions produces a wrap angle of 15.7 rad (900°).

9.2.3 Measure the length  $W$  of the intertwined portion of yarn. Measure the distance between the upper pulley axes  $2H$

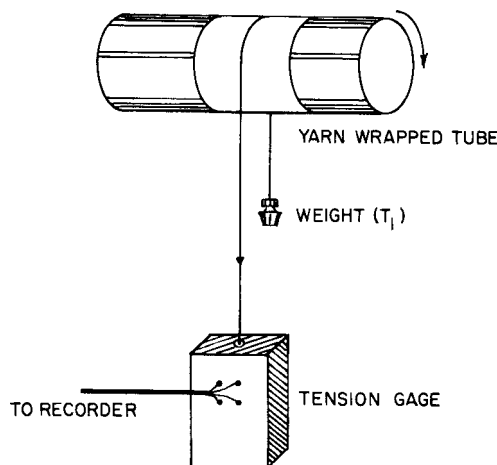

FIG. 2 Yarn-to-Yarn Friction Apparatus—Capstan Method

and the distance between the lower pulley axis and a line connecting the upper pulley axes  $V$ , or use the predetermined values for these constants. Calculate the apex angle  $\alpha$  formed between the input and output yarns using Eq 1:

$$\alpha = 2 \arctan = \left( \frac{H}{V-W} \right) \quad (1)$$

9.2.4 Place a mark on the input yarn immediately above its entry into the intertwisted region.

9.2.5 Adjust the input tension to  $10.0 \pm 0.5$  mN/tex (0.1 gf/den). If the yarn linear density is not known, determine as directed in Test Method D 1907 (Option I). For heavy yarns (30 tex or greater), an input tension of less than 10.0 mN/tex (0.1 gf/den) may be used for convenience.

9.2.6 Start the yarn takeup drive unit. Adjust the takeup speed to between 20 and 100 mm/min (0.75 and 4.0 in./min).

9.2.7 After the mark (9.2.4) has passed completely through the intertwisted region and is on the output side above the interwrapped region, measure the coefficient of friction or the input and output tensions. Record the values until an additional 100 mm (4 in.) of yarn has passed out of the interwrapped region. If stick-slip is present, record ten consecutive maximum values.

9.3 *Option 2 (Capstan Method):*

9.3.1 Using an auxiliary pulley above the mandrel, calibrate the apparatus by dead weight.

9.3.2 Wrap enough yarn from the specimen onto the cylinder to cover the surface.

9.3.3 Transfer the yarn-wrapped cylinder to the friction apparatus and hang a single strand of the same yarn over the cylinder, as shown in Fig. 2. For spun-staple yarns, use a double strand to prevent the twist from backing out.

9.3.4 Adjust the free-hanging weight to provide an input tension of  $10.0 \pm 0.5$  mN/tex (0.1 gf/den).

9.3.5 Measure and record the coefficient of friction or the output tension to the nearest 0.05 units.

## 10. Calculation

10.1 *Stick-Slip Present*—Determine the mean tension by averaging ten consecutive stick-slip peaks. This value is then used to calculate the coefficient of friction, unless the apparatus is directly calibrated in coefficient of friction.

10.2 *Stick-Slip Not Present*—Determine the mean output tension forces or mean coefficient of friction.

10.3 *Adjustment of Tensions (Twisted Strand Method)*—If the pulley friction value  $\Delta T$ , determined in 9.2.1, is greater than 5 % of the input tension, add half this value to the input tension and subtract half this value from the output tension. (These adjustments are reflected in Eq 2.)

10.4 *Average Coefficient of Friction (Twisted Strand Method)*—Calculate the average coefficient of friction, to the nearest 0.1 unit, unless it is recorded directly, using the formula in Eq 2:

$$\mu = \frac{\ln \frac{T_2 - \Delta T/2}{T_1 + \Delta T/2}}{2 \pi n_\alpha} \quad (2)$$

where:

$\mu$  = coefficient of friction,  
 $\ln$  = natural logarithm, to base e (2.718),  
 $T_1$  = mean input tension,  
 $T_2$  = mean output tension,  
 $\Delta T$  = zero twist tension (9.2.1),  
 $n$  = number of wraps (2.5), and  
 $\alpha$  = apex angle (Eq 1).

10.5 *Average Coefficient of Friction (Capstan Method)*—Calculate the average coefficient of friction, to the nearest 0.1 unit, unless it is recorded directly, using the formula in Eq 3:

$$\mu = \ln(T_2/T_1)/\theta \quad (3)$$

where:

$\mu$  = coefficient of friction,  
 $\ln$  = natural logarithm, to base e (2.718),  
 $T_1$  = mean input tension,  
 $T_2$  = mean output tension, and  
 $\theta$  = wrap angle, 3.14 rad (180°).

## 11. Report

11.1 State that the specimens were tested as directed in Test Method D 3412, Option 1 or Option 2. Describe the material(s) or product(s) sampled and the method of sampling used.

11.2 Report the following information:

- 11.2.1 Average coefficient of friction,
- 11.2.2 Whether stick-slip was present and, if so, the average peak-valley difference,
- 11.2.3 Yarn speed,
- 11.2.4 Wrap angle,
- 11.2.5 Yarn linear density,
- 11.2.6 Yarn input tension,
- 11.2.7 Yarn output tension,
- 11.2.8 For Option 1, whether Eq 2 or Eq 3 was used for the calculation.

NOTE 6—If the apparatus reads directly in coefficient of friction this should be stated and the yarn output tension omitted from the report.

## 12. Precision and Bias

12.1 *Interlaboratory Test Data*—An interlaboratory trial was run in 1969 in which randomly drawn samples of two yarns were tested in each of four laboratories using Procedure 1 and in each of two laboratories using Procedure 2. Each laboratory used one operator and tested two specimens of each yarn. The components of variance for yarn-to-yarn coefficient of friction were calculated to be:

	Procedure 1	Procedure 2
Single operator component	8.0	3.8 % of the average
Between-laboratory component	31.0	16.0 % of the average

12.2 *Precision*—For the components of variance reported in 12.1, two averages of observed values should be considered significantly different at the 95 % probability level if the difference equals or exceeds the critical differences listed below:

Number of observations in each average	Critical difference, % of grand average for the conditions noted <sup>A,B</sup>			
	Single operator precision Procedure		Between-laboratory precision Procedure	
	1	2	1	2
1	22	10.5	86	44
5	10	4.7	39	20
10	7	3.3	27	14

<sup>A</sup> The critical differences were calculated using  $t = 1.960$ , which is based on infinite degrees of freedom.

<sup>B</sup> To convert the values of the critical differences to units of measure, multiply the critical differences by the average of the two specific sets of data being compared and divide by 100.

NOTE 7—The tabulated values of the critical differences should be considered to be a general statement, particularly with respect to between-

laboratory precision. Before a meaningful statement can be made about two specific laboratories, the amount of statistical bias, if any, between them must be established, with each comparison being based on recent data obtained on specimens randomly drawn from one sample of the material to be tested.

12.3 *Bias*—No justifiable statement can be made on the bias of Test Method D 3412 for testing yarn-to-yarn coefficient of friction, since the true value of the property cannot be established by an accepted referee method.

### 13. Keywords

13.1 coefficient of friction; yarns; yarn to yarn

*The American Society for Testing and Materials takes no position respecting the validity of any patent rights asserted in connection with any item mentioned in this standard. Users of this standard are expressly advised that determination of the validity of any such patent rights, and the risk of infringement of such rights, are entirely their own responsibility.*

*This standard is subject to revision at any time by the responsible technical committee and must be reviewed every five years and if not revised, either reapproved or withdrawn. Your comments are invited either for revision of this standard or for additional standards and should be addressed to ASTM Headquarters. Your comments will receive careful consideration at a meeting of the responsible technical committee, which you may attend. If you feel that your comments have not received a fair hearing you should make your views known to the ASTM Committee on Standards, 100 Barr Harbor Drive, West Conshohocken, PA 19428.*

*This standard is copyrighted by ASTM, 100 Barr Harbor Drive, West Conshohocken, PA 19428-2959, United States. Individual reprints (single or multiple copies) of this standard may be obtained by contacting ASTM at the above address or at 610-832-9585 (phone), 610-832-9555 (fax), or service@astm.org (e-mail); or through the ASTM website (<http://www.astm.org>).*