



## Standard Test Method for Snagging Resistance of Fabrics (Mace Test Method)<sup>1</sup>

This standard is issued under the fixed designation D 3939; the number immediately following the designation indicates the year of original adoption or, in the case of revision, the year of last revision. A number in parentheses indicates the year of last reapproval. A superscript epsilon ( $\epsilon$ ) indicates an editorial change since the last revision or reapproval.

### 1. Scope

1.1 This test method determines the snagging resistance of a fabric.

1.2 Studies of fabric snagging have shown that this test method is suitable for a range of woven and knitted fabrics made from textured or untextured yarns containing staple or continuous filaments.<sup>2,3</sup> This test method is not suitable for (1) open construction fabrics (such as a net) because the points on the mace will snag the felt pad rather than the specimen, (2) very heavy or very stiff fabrics than cannot be made to fit tightly on the drum and felt pad, and (3) tufted or nonwoven fabrics because the apparatus is designed for woven and knitted fabrics.

1.3 The values stated in either acceptable metric units or in other units shall be regarded separately as the standard. The values stated in each system may not be exact equivalents; therefore, each system must be used independently of the other, without combining values in any way. In case of referee decisions, the metric units will prevail.

1.4 *This standard does not purport to address all of the safety concerns, if any, associated with its use. It is the responsibility of the user of this standard to establish appropriate safety and health practices and determine the applicability of regulatory limitations prior to use.* Specific precautionary statements are given in Section 7.

### 2. Referenced Documents

#### 2.1 ASTM Standards:

- D 123 Terminology Relating to Textiles<sup>4</sup>
- D 1335 Test Method for Tuft Bind of Pile Floor Coverings<sup>4</sup>
- D 1776 Practice for Conditioning Textiles for Testing<sup>4</sup>
- D 2724 Test Methods for Bonded, Fused, and Laminated Apparel Fabrics<sup>4</sup>
- D 3136 Terminology Relating to Permanent Labels for Consumer Textile and Leather Products and Other Textile Floor Coverings<sup>4</sup>

<sup>1</sup> This test method is under the jurisdiction of ASTM Committee D-13 on Textiles and is the direct responsibility of Subcommittee D13.59 on Fabric Test Methods, General.

Current edition approved Dec. 10, 1997. Published March 1997. Originally published as D 3939 – 80. Last previous edition D 3939 – 97.

<sup>2</sup> Finnigan, J. A., "Laboratory Prediction of the Tendency of a Fabric to Snag During Wear," *Textile Institute and Industry*, Vol 10, No. 6, 1972, pp. 164–167.

<sup>3</sup> Leung, P., and Hershkowitz, R., "Snag- and Fuzz-Resistant Double Knits via Fabric Construction," *Textile Research Journal*, Vol 45, No. 2, 1975, pp. 93–102.

<sup>4</sup> *Annual Book of ASTM Standards*, Vol 07.01.

D 4467 Practice for Interlaboratory Testing of a Test Method that Produces Non-Normally Distributed Data<sup>5</sup>  
D 5362 Test Method for Snagging Resistance of Fabrics (Bean Bag Test Method)<sup>5</sup>

#### 2.2 AATCC Standards:<sup>6</sup>

65 Snag Resistance of Women's Nylon Hosiery (see Note 1)  
135 Dimensional Changes in Automatic Home Laundering of Woven and Knit Fabrics

NOTE 1—In 1988, the AATCC voted to withdraw this method from its technical manual; however, the ASTM task group on fabric snagging decided it should be listed as an alternative for testing open construction fabrics.

### 3. Terminology

#### 3.1 Definitions of Terms Specific to This Standard:

3.1.1 *color contrast, n—in textiles*, a general term for a visible color difference between two adjacent areas.

3.1.1.1 *Discussion*—For the purpose of this test method, a color contrast is a visible color difference between a snag and the immediate surrounding area of the fabric that has no defects. Color contrasts often occur when printed fabrics are snagged.

3.1.2 *distortion, n—in fabrics*, a general term for a visible defect in the texture of a fabric.

3.1.2.1 *Discussion*—For the purpose of this test method, snags are composed of different combinations of protrusions and distortions. A distortion is characterized by a group of fibers, yarn, or a yarn segment that is displaced from its normal pattern so that there is a visible change in the texture of the fabric; however, the displaced group of fibers, yarn, or yarn segment does not extend above the fabric surface. Distortions include conditions where (1) tension on a snagged yarn has changed the size of some of the loops within a knitted fabric and the result is a pucker on the surface of the fabric, and (2) tension on a snagged yarn has caused the yarn to break off within a woven fabric and the result is a change in the texture where the yarn used to be.

3.1.3 *protrusion, n—in fabrics*, a general term for a visible group of fibers, a yarn, or a yarn segment that extends above the fabric surface.

3.1.4 *snag, n—in fabrics*, a yarn or part of a yarn pulled or plucked from the surface.

<sup>5</sup> *Annual Book of ASTM Standards*, Vol 07.02.

<sup>6</sup> Available from American Association of Textile Chemists and Colorists, P.O. Box 12215, Research Triangle Park, NC 27709.

3.1.4.1 *Discussion*—For the purpose of this test method, a snag is created when an object pulls, plucks, scratches, or drags a group of fibers, a yarn, or a yarn segment from its normal pattern. Snags can be classified into three types: (1) snags that have a protrusion and no distortion, (2) snags that have a distortion and no protrusion, and (3) snags that have both a protrusion and a distortion. Other changes in appearance, such as color contrasts, should be reported because they affect the visibility of a protrusion or a distortion.

3.1.5 *snagging resistance, n*—in textile fabrics, the property of a material whereby yarns or parts of yarns are prevented or inhibited from being pulled or plucked from the surface.

3.1.6 *Definitions*—For definitions of other textile terms used in this test method, refer to Terminology D 123.

#### 4. Summary of Test Method

4.1 Fabric Specimens in tubular form are placed one at a time on a cylindrical drum. A mace (spiked ball) is allowed to bounce randomly against each rotating specimen. As the mace bounces over each specimen, snags could occur to a degree affected by a variety of fabric factors. The degree of fabric snagging is then evaluated by comparison of the tested specimens with visual standards that may be either fabrics or photographs of fabrics. The observed resistance to snagging is reported on a scale ranging from No. 5 (no snagging) to No. 1 (very severe snagging).

#### 5. Significance and Use

5.1 This test method may be used to test the snagging resistance of most apparel and home furnishings fabrics. Modifications of this test method (see 5.1.1), or a different test method (see 5.1.2), may be needed for different types of fabrics and different end-uses (such as towels, pants, and upholstery).

5.1.1 For a specific fabric, if the test results from the mace test method do not correspond with the test results from a wear test, then (1) the procedure described in Section 12 or (2) the evaluation described in Section 13 can be modified. For

example, the number of revolutions (see 12.5) may be modified to provide meaningful test results. The purchaser and the supplier must agree to all changes in the procedure for operating the apparatus or for evaluating the test results.

5.1.2 Some fabrics that may not be suitable for this test method are described in 1.2. Many open construction fabrics can be tested for snagging resistance using AATCC Test Method 65. The snagging resistance of many pile floor coverings can be tested by Test Method D 1335.

5.2 Since fabric snagging can be affected by laundering or drycleaning, it may be advisable to test the snagging resistance of a fabric before and after laundering or drycleaning.

5.3 The snagging resistance of a specific fabric varies with individual wearers and general conditions of use. Therefore, it can be expected that garments of the same fabric will show a fairly wide snagging resistance spectrum after wear and much greater variation in wear than in replicate fabric specimens subjected to controlled laboratory tests. This factor should be considered when adopting levels of acceptability for any specification that includes snagging resistance.

5.4 Snags observed in worn garments vary appreciably in number and appearance. The appearance of a snag depends particularly on (1) the degree of color contrast between the snag and the surrounding area of the fabric or (2) the presence of long distortions or long protrusions. These conditions are not evaluated when snagging is rated solely on the number of snags. See Section 3 in this test method for a description of terminology such as color contrast, distortion, and protrusion; and see Figs. 1 through 3 in Test Method D 5362 for pictures of fabric defects due to snagging. Because the overall acceptability of a specific fabric is dependent on both the characteristics of the snags and other factors affecting fabric appearance, it is recommended that fabrics tested in the laboratory be evaluated with regard to the defects that may be observed visually and not rated solely on the number of snags developed. A series of visual rating standards (see 6.3.5) may be set up to provide a basis for the ratings. The visual rating standards are

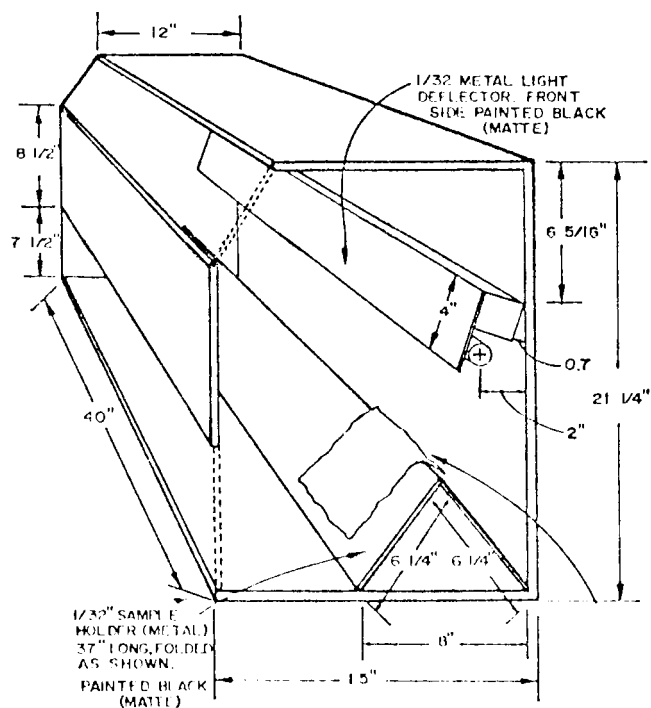

**FIG. 1 ABC Mace Tester**

**ASTM D 3939**



**FIG. 2 ICI Mace Tester**



**Metric Equivalents**

in.	mm	in.	mm
1/32	1	8	203
0.7	18	8 1/2	215
2	50	12	305
4	100	15	380
6 1/4	159	21 1/4	540
6 5/16	160	37	940
7 1/2	190	40	1020

**FIG. 3 Apparatus for Fabric Evaluation**

most advantageous when the tested laboratory specimens correlate closely in appearance with fabrics from a wear test, for example, when tested laboratory specimens and fabrics from a wear test show similar color contrasts. In the preceding example, a series of fabrics from the wear test would be a good

choice for the fabric standards described in 6.3.5.2.

5.5 This test method is recommended for quality control testing of fabrics during manufacturing and product comparisons of different fabrics by manufacturers, retailers, and users. This test method may also be used by researchers to examine

the effect of new fibers, yarns, fabric constructions, and finishes on the snagging resistance of fabrics.

5.6 This test method is not considered satisfactory for acceptance testing of commercial shipments of fabrics because the between-laboratory precision of the test method is poor (see 15.1).

5.6.1 In the case of a dispute arising from differences in reported test results when using this test method for acceptance testing of commercial shipments, the purchaser and the supplier should conduct comparative tests to determine whether a statistical bias exists between their laboratories. Competent statistical assistance is recommended for the investigation of bias.

5.6.2 As a minimum, the two parties should take a group of specimens that are as homogeneous as possible and that are from a lot of material of the type in question. The specimens should then be assigned randomly in equal numbers to each laboratory for testing. The results from the two laboratories should be compared using a nonparametric test for unpaired data and an acceptable probability level chosen by the two parties before the testing is started. If a bias is found, either its cause must be determined and corrected or the purchaser and the supplier must agree to interpret future test results in the light of the known bias.

## 6. Apparatus and Materials

### 6.1 Procedure 1:

6.1.1 *ABC Snag Tester*<sup>7</sup>—(see Fig. 1).

6.1.2 *Specimen Template*,<sup>7</sup> 150 by 330 mm or 6 by 13 in.

6.1.3 *Felt*,<sup>8</sup> for 150- by 330-mm or 6- by 13-in. pads.

6.1.4 *Gage*,<sup>7</sup> for ABC Snag Tester, for setting position of mace (calibration block).

6.1.5 *Masking Tape*, 25-mm or 1-in. single-face, and 50-mm or 2-in. double face.

### 6.2 Procedure 2:

6.2.1 *ICI Mace Snag Tester*<sup>9</sup> (see Fig. 2).

6.2.2 *Sample Templates*, 205 by 330 mm or 8 by 13 in. for weft knit fabrics and 205 by 320 mm or 8 by 12.5 in. for woven fabrics and warp knit fabrics.

6.2.3 *Felt Sleeves*.<sup>9</sup>

6.2.4 *Gage*,<sup>9</sup> for ICI Mace Snag Tester, for setting position of mace (calibration block).

6.2.5 *Rubber O-Rings*.<sup>9</sup>

### 6.3 Both Procedures:

6.3.1 *Sewing Machine*, with a sewing needle that is appropriate for the fabric being tested for snagging resistance, or

6.3.2 *Sharps Hand Sewing Needle*.

6.3.3 *Sewing Thread*, cotton, Tex ticket 35 to 50, or equivalent polyester and cotton.

<sup>7</sup> No company is currently manufacturing the ABC Snag Tester and there is no known supplier of parts for this tester. Information on the ABC Mace Tester is included in this test method because the tester is still being used to determine fabric snagging.

<sup>8</sup> Felt-Green S/924 (70 % wool, 30 % rayon), 1.6 mm or 1/16 in. in thickness, approximately 235 g/m<sup>2</sup> or 7 oz/yd<sup>2</sup>, available from Fidelity Felt and Manufacturing Co., Front and Venango Sts., Philadelphia, PA 19140, has been found suitable for this purpose.

<sup>9</sup> Available from Shirley Developments Limited, P.O. Box 162, Crown Royal, Shawcross Street, Stockport, SK13JW, England; represented by Crosrol Inc., P.O. Box 6488, Greenville, SC 29606.

6.3.4 *Standard Calibration Fabric*, having an established snagging resistance rating that has been agreed upon by the purchaser and the supplier. (No standard calibration fabric has been specified by Subcommittee D13.59.)

### 6.3.5 Visual Rating Standards:

6.3.5.1 *Photographic Standards*—A series of photographs of tested specimens that show the degrees of snagging, such as the Imperial Chemical Industries (ICI) photographs;<sup>9</sup> or

6.3.5.2 *Fabric Standards*—A series of tested specimens or fabrics from a wear test that show the degrees of snagging (see 5.4 and Note 2).

NOTE 2—Fabric standards should be stored and handled under conditions that will preserve their original form and appearance. Mount the fabric standards using white poster board or plastic or metal framing.

6.3.6 *Equipment for Fabric Evaluation*, for illumination and simultaneous viewing of specimens and visual rating standards. The lighting must have a cool white fluorescent tube(s) with a correlated color temperature of 4100 to 4500 K.

6.3.6.1 *Apparatus for Fabric Evaluation* (see Fig. 3),<sup>10</sup> or

6.3.6.2 *ICI Viewing Cabinet* (see Fig. 4).<sup>9</sup>

### 6.4 Optional Equipment:

6.4.1 *Steam Iron*, weighted to 2.3 kg or 5 lb and an ironing board.

6.4.2 *Automatic Electric Tumble Dryer*, as described in AATCC Test Method 135.

6.4.3 *Automatic Top-Loading Washer*, as described in AATCC Test Method 135.

6.4.4 *A Heavy Duty Granule Detergent*, equivalent to AATCC Standard Detergent 124 as described in AATCC Test Method 135. When agreed upon by the purchaser and the supplier, a substitute detergent that does not include fabric softener or bleach may be used.

6.4.5 *Equipment for Drycleaning Specimens*, as described in Test Methods D 2724.

## 7. Safety Precautions

7.1 Locate the mace snagging tester in a low-traffic area because of the danger from the exposed mace(s) and rotating drum(s).

7.2 Check that all parts of the mace snagging tester are secure and are in good working condition.

7.3 Wear protective gloves when examining the points on the mace snagging tester or removing fibers and yarns from the points.

7.4 Observe the following safety precautions when operating the tester: (1) do not wear loose or dangling clothing that can get caught in the points or moving parts; (2) do not attempt to change the specimen while the drum(s) is rotating; and (3) do not injure your hands on the sharp points when placing a specimen(s) on the drum(s).

## 8. Sampling

8.1 *Lot Sample*—As a lot sample for acceptance testing, take at random the number of shipping cartons or the number

<sup>10</sup> Available from Coronation Sheet Metal Co., 16 Somerset Place, Clifton, NJ 07012, and custom Scientific Instruments Inc., 13 Wing Drive, Cedar Knolls, NJ 07927.

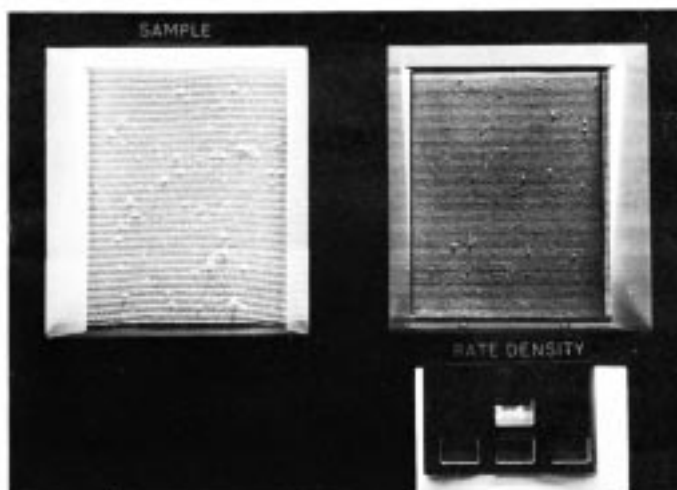

**FIG. 4 ICI Viewing Cabinet**

of rolls of fabric directed in an applicable material specification or other agreement between the purchaser and the supplier. Consider shipping cartons or rolls of fabric to be the primary sampling units.

**8.2 Laboratory Sample**—As a laboratory sample for acceptance testing, take at random the number of product items (such as pants or towels) from each shipping carton as specified in the agreement between the purchaser and the supplier. If the lot sample consists of a number of rolls of fabric, take a full width swatch 1-m or 1-yd. long from the end of each roll of fabric in the lot sample, after first discarding a minimum length of 3 m or 3 yd of fabric from the very outside of the roll. When drycleaning and laundering are to be performed, prepare additional product items or swatches for the laundering and drycleaning tests.

**8.3 Specimens**—Test four specimens as directed in Section 12 from each product item or each swatch in the laboratory sample. When drycleaning and laundering tests are to be performed, test four additional specimens for drycleaning and four additional specimens for laundering.

## 9. Preparation of the Specimens

**9.1** When snagging resistance after laundering or drycleaning is to be evaluated, launder or dryclean the product items or swatches as directed in 9.1.1 or 9.1.2 before the specimens are cut, or prepare the specimens as directed in an agreement between the purchaser and the supplier.

**9.1.1 Laundering**—Load the washer with a 3.5-kg or 8-lb total load of product items or swatches that comprise a homogeneous load (for example, same manufacturer, line, finishing, and previous care) or a homogeneous group of product items or swatches for testing and a desized unsoftened group of ballast fabrics. Select normal cycle, warm water temperature, and AATCC Standard Detergent 124 or equivalent detergent (see Terminology D 3136 and AATCC Test Method 135). Run one machine cycle and do not use softener. Load the dryer with the washed fabrics. Select normal cycle, medium temperature, and run the dryer for 20 min or until the fabrics are dry to the touch. Do not use softener in the dryer. Do

not overdry the fabrics. Repeat this procedure until five cycles of washing and drying have been completed (see Note 3).

**NOTE 3**—When agreed upon by the purchaser and the supplier, other laundering and drycleaning procedures may be used.

**9.1.2 Drycleaning**—Follow the procedure given in Test Methods D 2724 (see Note 3).

**9.2** Using the appropriate template (see 6.1.2 and 6.2.2), cut the following specimens: (1) for determination of the snagging resistance of the fabric in the wale or warp direction, cut two specimens, with the longer dimension parallel to the course or filling direction; and (2) for determination of snagging resistance of the fabric in the course or filling direction, cut two specimens, with the longer dimension parallel to the wale or warp direction. Unless otherwise specified by agreement between the purchaser and the supplier, do not take the specimens nearer the selvage than one tenth the width of the fabric. If possible, randomize the specimens in such a manner that no two contain the same set of yarns. Mark each specimen near an edge to indicate the following: (1) the face side that will later be tested for snagging resistance and (2) the type of specimen (wale or warp or filling).

**9.2.1** Similarly cut specimens from laundered or drycleaned product items or swatches, when required.

**9.3** Fold each specimen face side in and form a sleeve by sewing a seam parallel to the shorter dimension of the specimen at a distance from the edge sufficient for a tight fit on the drum (see Note 4). Use a minimum of 0.4 stitches/mm or 10 stitches/in. when machine or hand sewing the seam.

**NOTE 4**—It might be necessary in certain instances, such as on fabrics with high stretch or little or no stretch, to vary the distance of the seam line from the short edges in order to have a good running test specimen that is smooth and snug on the drum. The ICI Mace Snag Tester is supplied with a template for cutting out and marking weft knit fabrics and a template for cutting out and marking woven fabrics and warp knit fabrics. The weft knit template provides a specimen 205 by 330 mm or 8 by 13 in., and the seam line is 30 mm or 1 1/8 in. from the short edge. The woven or warp knit template is 205 by 320 mm or 8 by 12.5 in., and the seam line is 15 mm or 5/8 in. from the short edge.

9.4 Turn each specimen (sleeve) inside out to expose the surface for testing.

## 10. Preparation of Apparatus

### 10.1 Procedure 1 (ABC Snag Tester):

10.1.1 Attach a piece of 50-mm or 2-in. wide double-face masking tape parallel to the axis of the drum (long dimension).

10.1.2 Cut a piece of felt 150 by 330 mm or 6 by 13 in.

10.1.3 Wrap the felt around the drum and press the short ends into the double-face masking tape (see Fig. 5). Take care that the felt is smooth (see Note 5).

NOTE 5—Trim and butt the ends of the felt for a smooth fit.

10.1.4 Fasten the edges of the felt to the ends of the drum with 25-mm or 1-in. single-face masking tape. The tape should be half on the felt and half on the rubber-covered drum.

10.1.5 Replace the felt whenever its surface becomes rough, has holes, or shows excessive wear (see Note 6).

NOTE 6—As a guide, replace the felt after no more than 200 h of running.

### 10.2 Procedure 2 (ICI Mace Snag Tester):

10.2.1 Position the felt sleeve centrally on the drum, wet it with hot water, remove the surplus moisture, and allow to dry completely. Slight heat can be used to accelerate the drying, if necessary. The sleeve will fit tightly on the drum when shrunk.

10.2.2 Replace the felt whenever its surface becomes rough, has holes, or shows excessive wear (see Note 6).

10.3 *Conditioning and Adjustment of Mace* (Procedures 1 and 2):

10.3.1 Check the points on the mace to be certain that there are no barbs or other damage by feeling the points for roughness. Inspection of the points under a magnifying glass will show the bad points. Check the points daily, or whenever a mace position is suspected of snagging too severely or erratically. Replace the worn or damaged points.

10.3.2 Adjust the distance of the mace from the drag bar with the 45-mm or 1.8-in. calibration block, or measure as shown in Fig. 6 by adjusting the screw at the upper coupling. Check this distance daily or whenever a mace position is suspected of not working properly.

10.3.3 Check the ball for freedom of movement in its socket on the Link Chain.

10.3.4 Set the timing/counting mechanism for 600 total revolutions (approximately 10 min) and verify that the drum speed is  $60 \pm 2$  r/min.

10.4 *Calibration of Tester* (Procedures 1 and 2) (see Note 7):

NOTE 7—There are significant differences between the ABC and ICI snag testers. Consequently, the test results obtained from these two testers may or may not correlate with each other.

10.4.1 Check the operation of the snagging tester with the standard calibration fabric of known snagging resistance rating. If the equipment is in daily use, check daily; if testing is infrequent, check the equipment each time it is used.

10.4.2 If the test result obtained on the standard calibration fabric is not within a  $\pm 0.5$  rating unit of the established value, run another specimen. If this second specimen is within limits, continue testing; if not, check 10.3.1-10.3.4. Repeat, as required, until a specimen is within limits.

## 11. Conditioning

11.1 Preconditioning is not necessary. Place all of the specimens in the standard atmosphere for testing textiles, which is  $21 \pm 1^\circ\text{C}$  ( $70 \pm 2^\circ\text{F}$ ) and  $65 \pm 2\%$  relative humidity (see Practice D 1776), for a minimum of 12 h before testing. While this conditioning does not necessarily result in equilibrium moisture content in the specimens, it is deemed adequate for the purposes of this test method.

## 12. Procedure

12.1 Test all specimens in the standard atmosphere for testing textiles, which is  $21 \pm 1^\circ\text{C}$  ( $70 \pm 2^\circ\text{F}$ ) and  $65 \pm 2\%$  relative humidity.

12.2 Inspect the specimens for the presence of any blemish such as accidental snags, pills, etc., which could affect the ratings for snagging resistance. If possible, replace any blemished specimen with a specimen that has no blemish and has been prepared and conditioned as directed in Sections 9 and 11. If it is not possible to replace the specimen (for example, the specimen pilled during laundering), record the fact and exclude the blemish when the specimen is evaluated for snagging resistance.

12.3 Place a tubular specimen onto the felt-covered drum with the face of the specimen outwards and with the seam

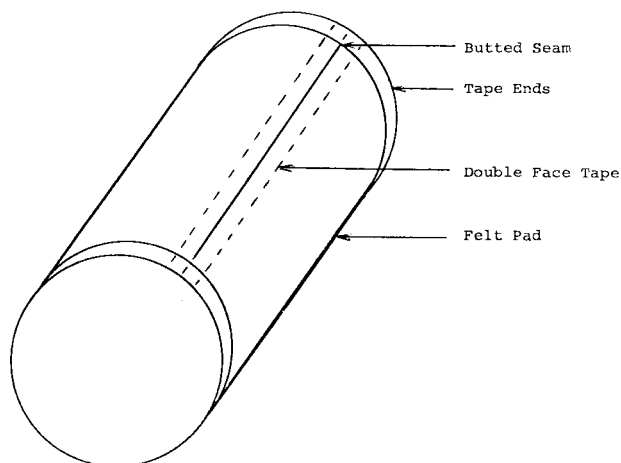

**FIG. 5 Mounting of Felt Pad on ABC Snag Tester**



NOTE 1—Adjustment on ABC Snag Tester is from opposite side.

**FIG. 6 Adjusting Mace on ICI Snag Tester**

overlap flattened to each side of the seam. Secure the specimen to the drum by taping the edges with 25-mm or 1-in. single-face masking tape, half on the specimen and half on the drum or with rubber O-rings (see Fig. 7), depending on the procedure used (see Note 8).

NOTE 8—If the mace snag tester has more than one drum, half of the specimens being tested should be wale or warp specimens and the other half should be course or filling specimens. Avoid placing the wale or warp specimens or the course or filling specimens on any particular drum (for example, do not always place the warp specimen on the left drum), as this may introduce bias into the results.

12.3.1 When testing the course direction of knit samples (long specimen direction parallel to the wale direction of the specimen), mount one of the specimens with the loop heads facing to the right of the tester and the other with the loop heads facing to the left, since there can be differences in snagging resistance between the two mountings.

12.4 Position the mace (Fig. 6) to allow freedom of movement over the entire drum surface.

12.5 Unless otherwise specified, set the counter for 600 revolutions (approximately a 10-mm test) and operate the mace snagging tester.

12.6 Remove the specimens from the drums.

12.7 Fold the specimen with the seam in the center and to the back of the specimen.

12.8 *Optional:*

12.8.1 Place the side of the specimen to be rated facing the ironing board (seam facing down).

12.8.2 Preheat the steam iron to 170°C (338°F), or to the safe ironing temperature for the specific fibers in the fabric.

12.8.3 Steam-iron the specimen in both fabric directions for a total of 10 to 12 s, using only the weight of the iron for pressure.

### 13. Evaluation

13.1 Choose the visual rating standards (see 6.3.5) and the equipment for fabric evaluation (see 6.3.6). If a purchase order between the purchaser and the supplier does not specify the visual rating standards of the equipment for fabric evaluation, then ICI photographic snagging standards (see Note 9) and the apparatus for fabric evaluation (see Fig. 3) are recommended.

NOTE 9—The ICI photographic snagging standards consist of a set of nine photoreplicas in which the half rating is indicated as 3–4, 2–3, etc. Because the ICI standards differ only in the number of protrusions, it is recommended that appearance changes, such as color contrasts, also be reported (see 14.2.7).

13.2 If the ICI photographic snagging standards and the apparatus for fabric evaluation (viewing cabinet) have been selected, rate the appearance of the face (as indicated by markings) of each specimen. Rate for density of snagging on the face side opposite the seam on an evaluation area corresponding to the area of the rating standards being used (see

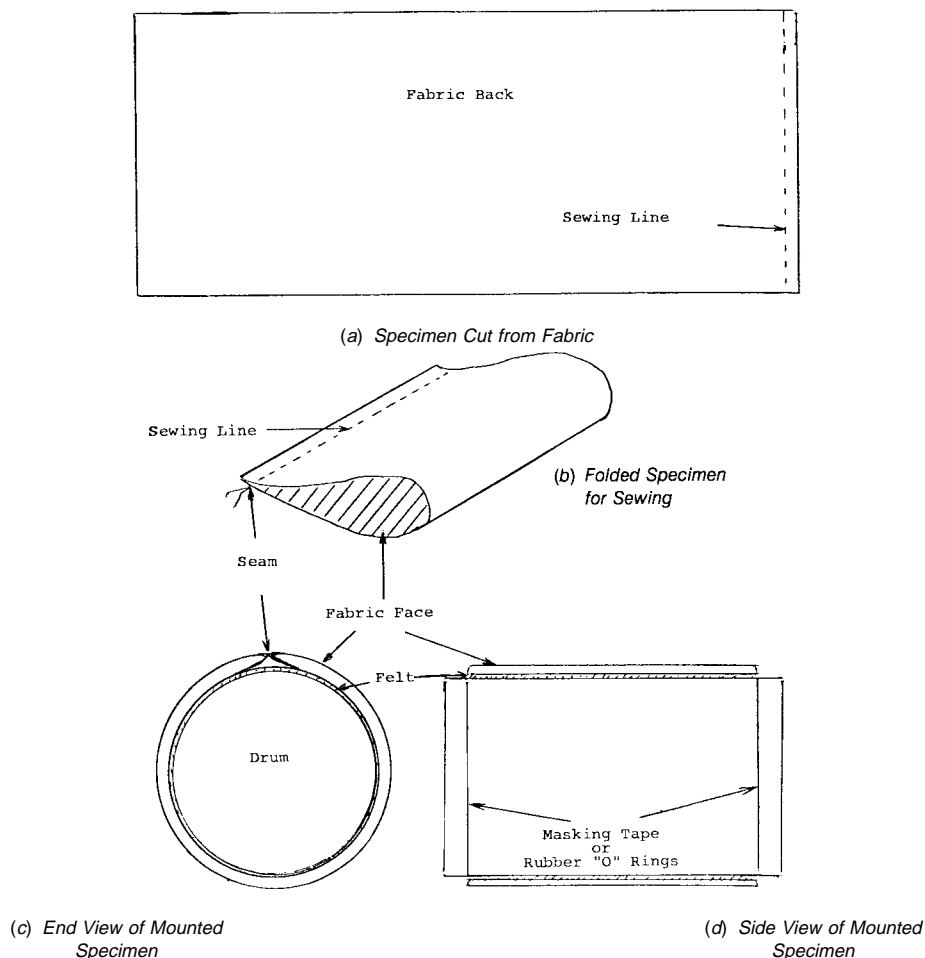

**FIG. 7 Preparation and Mounting of Specimen**

Note 10), in accordance with the following scale (see Note 11):

- 5 no snagging
- 4 slight snagging
- 3 moderate snagging
- 2 severe snagging
- 1 very severe snagging

When the appearance of a specimen falls roughly equidistant between that of two whole number rating standards, assign the half value, for example, 2-3, 2-5, etc.

NOTE 10—The outer dimensions of the ICI photographic snagging standards are 130 by 95 mm or 5.2 by 3.8 in., and the evaluation area of each specimen should be the same size as the standard. It is recommended that a standard specimen viewing mask be used to be sure the evaluation area of each specimen is the same size as the outer dimensions of the ICI photographic snagging standards. This mask can be made of approximately 2-mm or 0.1-in. thick poster board, plastic or metal. For the ICI photographic snagging standards, the white mask for the specimen should have a center cutout of 130 by 95 mm or 5.2 by 3.8 in., and the outer dimensions should be large enough so the mask can sit on the base of the apparatus for fabric evaluation (see Fig. 3).

NOTE 11—Rating standards assembled from tested specimens of the types of fabrics tested, representing the level of snagging equivalent to each of the five rating steps, are valuable as a reference to ensure uniformity in rating. Individual laboratories should have available rating standards for each type of fabric of particular interest.

13.2.1 If there is greater than a 1.0 scale unit difference between specimens from the same fabric direction, run two

new specimens from that particular direction and average all four observations to the nearest 0.1 scale unit.

13.2.2 For each product item or swatch in the laboratory sample, the average of the specimens that were cut with the long dimension running parallel to the fabric length (wale or warp) direction shall be the rating for the course or filling test, and the average of the specimens that were cut with the long dimension running parallel to the fabric width (course or filling) direction shall be the rating for the wale or warp specimens. All averages should be to the nearest 0.1 scale unit.

13.2.3 For each product item or swatch in the laboratory sample, calculate the overall average rating by averaging the observations from all the specimens to the nearest 0.1 scale unit.

13.2.4 For each product or swatch in the laboratory sample, examine the specimens to determine whether color contrasts, long distortions (longer than 15 mm or 0.6 in.), or long protrusions (longer than 4 mm or 0.15 in.) are present. If at least half of the specimens have color contrasts, long distortions, or long protrusions, then these attributes should be reported (see 14.2.7). For standards that differ only in the number of protrusions (see Note 9), also report the presence of short distortions (shorter than or equal to 15 mm or 0.6 in.) if short distortions were found on at least half of the specimens.

13.3 If a purchase order between the purchaser and the

supplier specifies an evaluation procedure that is different than the procedure described in 13.2-13.2.4, follow the evaluation procedure specified in the purchase order (see Note 12).

NOTE 12—When rating the specimens, the rater's eyes must be approximately 300 mm or 12 in. from the fabric surface. This is the rating distance used in 6.3.6.1.

13.4 If other visual rating standards or equipment for fabric evaluation were selected in 13.1 (such as fabric standards or the ICI viewing cabinet), the evaluation procedures described in 13.2-13.2.4 will have to be adapted to the standards and equipment actually used (see Note 12).

## 14. Report

14.1 State that the specimens were tested as directed in this test method. Describe the material or product sampled, the method of sampling used, and whether Procedure 1 or 2 was used.

14.2 Report the following information:

14.2.1 Method of preparation of the specimens, including the use of laundering or drycleaning.

14.2.2 Distance of the seam line from the short edges of each specimen.

14.2.3 Duration of test in number of revolutions, if other than 600.

14.2.4 Visual rating standards and viewing cabinet used to rate the specimens.

14.2.5 Whether the samples were ironed or not and, if so, at what temperature.

14.2.6 For each product item or swatch in the laboratory sample, the average of all of the specimens that were cut with the long dimension running in the fabric length direction (this is a course or filling test) and the average of all of the specimens that were cut with the long dimension running in the fabric width direction (this is a wale or warp test), plus the number of specimens in each average.

14.2.7 For each product item or swatch in the laboratory sample, the overall average of all specimens and any appearance changes (see 13.2.4) in the specimens.

14.2.8 If laundering tests were conducted, repeat 14.2.2-14.2.7 for the laundered specimens.

14.2.9 If drycleaning tests were conducted, repeat 14.2.2-14.2.7 for the drycleaned specimens.

**TABLE 1 Interlaboratory Test of the Mace Test Method**

Laboratory	Material						Average
	A	B	C	D	E	F	
I	3.5	4.3	4.5	4.3	3.8	5.0	4.2
II	3.0	3.9	3.8	4.1	3.5	4.5	3.8
III	2.3	2.7	2.8	3.7	2.8	4.1	3.1
IV	2.8	3.6	3.8	4.5	3.4	4.9	3.8
Average	2.9	3.6	3.7	4.1	3.4	4.6	

## 15. Precision and Bias

15.1 *Precision*<sup>11</sup>—In 1972, the results of an interlaboratory study of the ICI Mace Tester were reported by J. A. Finnigan.<sup>12</sup> This interlaboratory study had six bulked-polyester double-jersey materials, four laboratories, one operator at each laboratory, and four specimens (two wale and two course) for each material. Because the test results of the Mace Test Method are expressed as nine rating steps or grades, the data from this study fit a non-normal distribution. Table 1 gives the results from the interlaboratory study, with each datum within the body of the table being a mean of four specimens (these data are from Finnigan's Table I—Assessment X). Using the Friedman Rank Sum Test described in Practice D 4467, the Friedman Rank-Sum Statistic for the difference between laboratories was calculated by the D13.59 snagging task group to be 14.55. This statistic was significant at the 5 % level of significance, indicating that the laboratories were obtaining different test results for each material.

15.1.1 Using a different type of analysis, Finnigan concluded that significant interlaboratory differences did exist, so all of the specimens were sent to one laboratory to be rated by one experienced rater. For each of the materials, when the specimens were re-evaluated by one experienced rater, there was good agreement among the test results from the specimens snagged by different laboratories. Finnigan concluded that the effect of the machines was not significant, but the effect of having raters with various levels of training was significant. Finnigan recommended that all raters use the same rating procedures to obtain consistent test results.

15.1.2 A way to develop more consistent rating procedures among the raters would be to have a set of snagged specimens that have been evaluated by experienced raters and then to circulate the specimens and correct ratings among the laboratories for training new operators.

15.2 *Bias*—The procedure in this test method has no bias because the value of this property can be defined only in terms of a test method.

## 16. Keywords

16.1 knit fabric; mace test method; snagging resistance; woven fabric

<sup>11</sup> Supporting data are available from ASTM Headquarters. Request RR:D13-1081.

<sup>12</sup> See Footnote 2 for the reference. Written permission to use the data from the Finnigan study was obtained from The Textile Institute.

**NOTICE: This standard has either been superseded and replaced by a new version or discontinued.  
Contact ASTM International ([www.astm.org](http://www.astm.org)) for the latest information.**

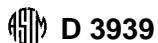

*The American Society for Testing and Materials takes no position respecting the validity of any patent rights asserted in connection with any item mentioned in this standard. Users of this standard are expressly advised that determination of the validity of any such patent rights, and the risk of infringement of such rights, are entirely their own responsibility.*

*This standard is subject to revision at any time by the responsible technical committee and must be reviewed every five years and if not revised, either reapproved or withdrawn. Your comments are invited either for revision of this standard or for additional standards and should be addressed to ASTM Headquarters. Your comments will receive careful consideration at a meeting of the responsible technical committee, which you may attend. If you feel that your comments have not received a fair hearing you should make your views known to the ASTM Committee on Standards, at the address shown below.*

*This standard is copyrighted by ASTM, 100 Barr Harbor Drive, PO Box C700, West Conshohocken, PA 19428-2959, United States. Individual reprints (single or multiple copies) of this standard may be obtained by contacting ASTM at the above address or at 610-832-9585 (phone), 610-832-9555 (fax), or [service@astm.org](mailto:service@astm.org) (e-mail); or through the ASTM website ([www.astm.org](http://www.astm.org)).*