



Standard Test Methods for Tire Cords, Tire Cord Fabrics, and Industrial Filament Yarns Made from Manufactured Organic-Base Fibers¹

This standard is issued under the fixed designation D 885; the number immediately following the designation indicates the year of original adoption or, in the case of revision, the year of last revision. A number in parentheses indicates the year of last reapproval. A superscript epsilon (ε) indicates an editorial change since the last revision or reapproval.

1. Scope

1.1 These test methods cover the testing of industrial filament yarns made wholly of manufactured organic-base fibers, cords twisted from such yarns, fabrics woven from such cords, and products that are made specifically for use in the manufacture of pneumatic tires. They may be applied to similar yarns and cords used for reinforcing other rubber goods and for other industrial applications. The test methods apply to nylon, polyester, rayon, and aramid yarns and tire cords twisted from such yarns and to fabrics made from such cords. The yarn or cord may be wound on cones, tubes, bobbins, spools, or beams; may be woven into fabric; or may be in some other form. The methods include testing procedure only and include no specifications or tolerances.

1.2 No procedure is included for the determination of fatigue resistance of cord, but several commonly used procedures for the measurement of fatigue resistance of cords in rubber were published in the appendix of these test methods in the *1967 Annual Book of ASTM Standards*, Part 24, and in earlier issues of Test Methods D 885.

1.3 The sections on “Growth of Conditioned Yarns and Cords,” “Properties of Yarns and Cords at Elevated Temperature,” and “Properties of Wet Yarns and Cords” have been moved to Appendix X1-Appendix X3 as non-mandatory informational items because of their very limited use by the industry and because precision and bias statements are not included.

1.4 This standard includes the following sections:

Adhesion of Cord to Elastomers	Section 34
Bibliography of Tire Cord Test Methods	X4
Breaking Strength (Force) of Yarns and Cords at Elevated Temperature	X2.3
Breaking Strength (Force) of Conditioned Yarns and Cords	16
Breaking Strength (Force) of Oven-Dried Rayon Yarns and Cords	23
Breaking Strength (Force) of Rayon Yarns and Cords at Specified Moisture Regain Level, Adjustment of	17
Breaking Tenacity of Conditioned Yarns and Cords	18
Breaking Tenacity of Oven-Dried Rayon Yarns and Cords	24
Breaking Toughness of Yarns and Cords	28
Commercial Mass	9

Conditioning	7
Contraction of Wet Yarns and Cords	X3
Count of Tire Cord Fabric	37
Dip (Adhesive) Solids Pickup on Yarns and Cords	33
Elongation at Break of Conditioned Yarns and Cords	19
Elongation at Break of Oven-Dried Rayon Yarns and Cords	25
Elongation of Rayon Yarns and Cords at a Specified Moisture Regain Level, Adjustment of	20
Extractable Matter in Yarns and Cords	32
Force at Specified Elongation (FASE) of Conditioned Yarns and Cords	21
Force at Specified Elongation (FASE) of Oven-Dried Rayon Yarns and Cords	26
Growth of Conditioned Yarns and Cords	X1
Identification of Fibers	8
Keywords	40
Linear Density	11
Mass of per Unit Area of Tire Cord Fabric	36
Modulus of Conditioned Yarns and Cords	22
Moisture Regain, Actual	10
Precision and Bias of Certain Cord Tests	39
Properties of Tire Cord Fabric	35 to 37
Sampling	6
Shrinkage Force of Conditioned Yarns and Cords at Elevated Temperature	X2.5
Shrinkage of Conditioned Yarns and Cords at Elevated Temperature	X2.4
Significance and Use, General	5
Significance and Use, Tensile Properties	14
SI Calculations (examples for work-to-break, specific work-to-break, and breaking toughness)	X5
Stiffness of Fabric	38
Tensile Properties of Yarns and Cords	12 to 28
Terminology	3
Thickness of Cords	31
Twist in Yarns and Cords	30
Width of Tire Cord Fabric	35
Work-to-Break of Yarns and Cords	27

1.5 These test methods show the values in both SI and inch-pound units. SI units is the technically correct name for the system of metric units known as the International System of Units. Inch-pound units is the technically correct name for the customary units used in the United States. The values stated in either acceptable metric units or other units shall be regarded separately as standard. The values expressed in each system may not be exact equivalents; therefore, each system must be used independently of each other, without combining values in any way.

1.6 *This standard does not purport to address all of the safety concerns, if any, associated with its use. It is the*

¹ These test methods are under the jurisdiction of ASTM Committee D-13 on Textiles and are the direct responsibility of Subcommittee D13.19 on Tire Cord Fabrics.

Current edition approved March 10, 1998. Published August 1998. Originally published as D 885 – 46T. Last previous edition D 885 – 94.

responsibility of the user of this standard to establish appropriate safety and health practices and determine the applicability of regulatory limitations prior to use.

2. Referenced Documents

2.1 ASTM Standards:

- D 76 Specification for Tensile Testing Machines for Textiles²
- D 123 Terminology Relating to Textiles²
- D 276 Test Methods for Identification of Fibers in Textiles²
- D 1423 Test Method for Twist in Yarns by the Direct-Counting Method²
- D 1777 Test Method for Thickness of Textile Materials²
- D 1907 Test Method for Yarn Number by the Skein Method²
- D 1909 Table of Commercial Moisture Regains for Textile Fibers²
- D 2138 Test Methods for Rubber Property—Adhesion to Textile Cord³
- D 2256 Test Methods for Tensile Properties of Yarns by the Single-Strand Method²
- D 2257 Test Method for Extractable Matter in Textiles²
- D 2258 Practice for Sampling Yarn for Testing²
- D 2462 Test Method for Moisture in Wool by Distillation with Toluene²
- D 2494 Test Method for Commercial Mass of a Shipment of Yarn or Man-Made Staple Fiber or Tow²
- D 2654 Test Methods for Moisture in Textiles²
- D 2969 Test Method for Steel Tire Cords²
- D 2970 Test Methods for Tire Cords, Tire Cord Fabrics, and Industrial Yarns Made from Glass Filaments²
- D 3774 Test Method for Width of Textile Fabric⁴
- D 3775 Test Method for Fabric Count of Woven Fabric⁴
- D 3776 Test Method for Mass per Unit Area (Weight) of Fabric⁴
- D 4393 Test Method for Strap Peel Adhesion of Reinforcing Cords or Fabrics to Rubber Compounds⁴
- D 4776 Test Method for Adhesion of Tire Cords and Other Reinforcing Cords to Rubber Compounds by H-Test Procedure⁴
- D 4848 Terminology of Force, Deformation and Related Properties of Textiles⁴
- D 5591 Test Method for Thermal Shrinkage Force of Yarn and Cord Using The Testrite Thermal Shrinkage Force Tester⁴

3. Terminology

3.1 Definitions:

3.1.1 *breaking force, n*—the maximum force applied to a material carried to rupture.

3.1.1.1 *Discussion*—Materials that are brittle usually rupture at the maximum force. Materials that are ductile usually experience a maximum force before rupturing. For many years, it has been the usual practice in the tire industry and related

industries to use the term *breaking strength* to characterize yarn and cord of a specified size and type without any reduction to unit size. Numerically, *breaking strength* is equal to breaking force for the same specimen. The average of the breaking forces observed on two or more specimens of a specific sample is referred to as the sample breaking strength, which is the property used in engineering calculations for a specific textile material. *Tensile strength* and *breaking tenacity* are derived or calculated values that characterize a type or class of material reduced to unit size. These terms can be used to compare intrinsic strengths of yarns and cords of different sizes or different materials. The term *tensile strength*, in MPA (psi), is not synonymous with either *breaking force* or *breaking strength* in N (lbf), or *breaking tenacity*, in mN/tex (gf/den).

3.1.2 *breaking strength, n*—strength expressed in terms of breaking force.

3.1.2.1 *Discussion*—Breaking strength is particularly significant as the characteristic of a sample as distinct from a specimen, and usually is expressed as newtons (N) or pounds-force (lbf) (see 3.1.1.1).

3.1.3 *breaking tenacity, n*—the tenacity at the breaking force.

3.1.3.1 *Discussion*—See 3.1.1.1.

3.1.4 *breaking toughness, n*—the actual work per unit volume or per unit mass of material that is required to rupture the material.

3.1.4.1 *Discussion*—Breaking toughness is represented by the area under the stress-strain curve from the origin to the breaking force per unit length.

3.1.5 *chord modulus, n*—in a *stress-strain curve*, the ratio of the change in stress to the change in strain between two specified points on the curve.

3.1.6 *cord, n*—a twisted or formed structure composed of one or more single or plied filaments, strands, or yarns of organic polymer or inorganic materials.

3.1.6.1 *Discussion*—Cord, as used in these test methods, is used for the manufacture of pneumatic tires or other industrial fabrics.

3.1.7 *cord twist, n*—the amount of twist in a cord made from two or more single or plied yarns.

3.1.7.1 *Discussion*—Cord twist is based on the initial length of a cord specimen.

3.1.8 *dip, n*—a chemical composition that is applied to a textile cord or fabric to improve its adhesion to rubber or other elastomer.

3.1.9 *dip pickup, n*—in a *textile cord or fabric*, the amount of dip or dip components present after processing, including drying, as determined by prescribed methods, and expressed as a percentage of the mass of the oven-dried, dip-free material.

3.1.10 *elongation, n*—the ratio of the extension of a material to the length of the material prior to stretching.

3.1.10.1 *Discussion*—Elongation may be measured at any specified force or at rupture.

3.1.11 *fabric, n*—in *textiles*, a planar structure consisting of yarns or fibers.

3.1.11.1 *Discussion*—For fabrics made of tire cord—consists of tire cord warp yarns with widely spaced filling yarn.

3.1.12 *force at specified elongation (FASE), n*—the force

² Annual Book of ASTM Standards, Vol 07.01.

³ Annual Book of ASTM Standards, Vol 09.01.

⁴ Annual Book of ASTM Standards, Vol 07.02.

associated with a specific elongation on the force-extension or force-elongation curve.

3.1.13 *growth, n*—the increase in length of a specimen caused by the application of a continuing load or force under specified conditions.

3.1.14 *industrial yarn, n*—a yarn composed of continuous filaments, usually of high breaking tenacity, produced with or without twist; and intended for applications in which functional properties are of primary importance; for example, and in reinforcing material in elastomeric products (tires, hose, and belting), in protective coverings, in cordage and webbing, and so forth.

3.1.15 *initial modulus, n*—the slope of the initial straight portion of a stress-strain (or force-elongation) curve.

3.1.15.1 *Discussion*—Modulus is the ratio of the change in tenacity, expressed in millinewtons per tex (mN/tex) or grams-force per denier (gf/den) to the change in strain, expressed as a fraction of the original length. In the case of a tenacity elongation curve, the following equation is used to calculate the initial modulus:

$$\text{Initial modulus} = (\text{tenacity/percent elongation}) \times 100 \quad (1)$$

3.1.16 *moisture equilibrium for testing, n*—for industrial yarns and tire cords, the condition reached when, after free exposure to a test atmosphere that is in motion, two successive weighings not less than 4 h apart show not more than 0.1 % progressive change in mass of the specimen or sample.

3.1.17 *pneumatic tire, n*—a hollow tire that becomes load-bearing upon inflation with air, or other gas, to a pressure above atmospheric.

3.1.18 *single twist, n*—the amount of twist in each individual single yarn element in a tire cord structure based on the length of the element after twist has been removed from the cord.

3.1.19 *standard atmosphere for testing textiles, n*—laboratory conditions for testing fibers, yarns, and fabrics in which air and relative humidity are maintained at specific levels within established tolerances.

3.1.19.1 *Discussion*—Air is maintained at a relative humidity of $55 \pm 2\%$ and at a temperature of $24 \pm 1^\circ\text{C}$ ($75 \pm 2^\circ\text{F}$) for this test method.

3.1.20 *tabby sample, n*—the section of tire cord fabric between two tabbies that have been woven separately with a distance of 0.5 to 1.0 m (18 to 36 in.) between them.

3.1.20.1 *Discussion*—A tabby usually is woven 150 to 200 mm (6 to 8 in.) in length using cotton filling yarn in the range from 750 to 2000 tex (675 to 1800 denier) and 30 to 50 picks/dm (8 to 12 picks/in.).

3.1.21 *tensile strength, n*—the strength of a material under tension as distinct from compression, torsion, or shear.

3.1.21.1 *Discussion*—Technically, strength is a characteristic that is expressed in terms of force. Historically, however, tensile strength has been commonly expressed in terms of force per unit base, for example, the cross-sectional area of the unstrained material. Some common units are Pascal (Pa), which is newtons per square metre (N/m^2) and pounds-force per square inch (psi) (see 3.1.1.1).

3.1.22 *tire, n*—a load-bearing ground-contacting circumferential attachment to a vehicle wheel.

3.1.23 *tire cord fabric, n*—a fabric consisting of tire cord warp with widely spaced (usually 40 to 200 picks/m (1 to 5 picks/in.)) single yarn filing.

3.1.24 *work-to-break, n*—the total energy required to rupture a specimen to the breaking force during a tensile test.

3.1.24.1 *Discussion*—Work-to-break is proportional to the area under the stress-strain curve from the origin to the breaking force.

3.1.25 For definitions of terms related to force and deformation in textiles, refer to Terminology D 4848. For definitions of other terms related to textiles, refer to Terminology D 123.

3.2 Definitions of Terms Specific to This Standard:

3.2.1 *aramid, n*—for the purpose of these test methods, those aramid yarns with a chord modulus of at least 35 N/tex (400 gf/den).

4. Summary of Test Methods, General

4.1 A summary of the directions prescribed for the determination of specific properties is stated in the appropriate sections of specific test methods.

5. Significance and Use, General

5.1 The procedures in these test methods should be used with caution for acceptance of commercial shipments owing to the absence of factual information on the between-laboratory precision of many of the test procedures included in these test methods. It is recommended that any program of acceptance testing be preceded by an interlaboratory check in the laboratory of the purchaser and the laboratory of the supplier on replicate specimens of the materials to be tested for each property (or properties) to be evaluated.

5.1.1 If there are differences of practical significance between reported test results for two laboratories (or more), comparative tests should be performed to determine if there is a statistical bias between them, using competent statistical assistance. As a minimum, test samples should be used that are as homogeneous as possible, that are drawn from the material from which the disparate test results were obtained, and that are randomly assigned in equal numbers to each laboratory for testing. Other materials with established test values may be used for this purpose. The test results from the two laboratories should be compared using a statistical test for unpaired data, at a probability level chosen prior to the testing series. If a bias is found, either its cause must be found and corrected, or future test results must be adjusted in consideration of the known bias.

5.2 The significance and use of particular properties are discussed in the appropriate sections of specific test methods.

6. Sampling

6.1 Yarn:

6.1.1 *Packages*—For acceptance testing, sample each lot as directed in Practice D 2258. Place each laboratory sampling unit in a moisture-proof polyethylene bag or other moisture-proof container to protect the samples from atmospheric changes until ready to condition the samples in the atmosphere for testing industrial yarns and tire cords. Take the number of specimens for testing specified for the specific property measurement to be made.

6.1.2 *Beams*—For acceptance testing, sample by winding yarns on a tube or spool by means of a winder using a tension of 5 ± 1 mN/tex (0.05 ± 0.01 gf/den). Take the yarn from the outside beam layers unless there is a question or disagreement regarding the shipment; in this case, take the sample only after removing yarn from the beam to a radial depth of 6 mm ($1/4$ in.) or more to minimize the effects of handling and atmospheric changes that may have occurred during shipment or storage. Place each laboratory sampling unit in a moisture-proof polyethylene bag or other moisture-proof container to protect the samples from atmospheric changes until ready to condition the samples in the atmosphere for testing industrial yarns and tire cords. Take the number of specimens for testing specified for the specific property measurement to be made.

6.2 *Cord:*

6.2.1 *Number of Samples and Specimens*—The size of an acceptance sampling lot of tire cord shall be not more than one truck or rail car load or as determined by agreement between the purchaser and the supplier. Take samples at random from each of a number of cones, tubes, bobbins, or spools within a lot to be as representative as possible within practical limitations. Make only one observation on an individual package for each physical property determination. Take the number of samples, therefore, that will be sufficient to cover the total number of specimens required for the determination of all physical properties of the tire cord. The recommended number of specimens is included in the appropriate sections of specific test methods covered in this standard. Where such is not specified, the number of specimens is as agreed upon between buyer and supplier.

6.2.2 *Preparation of Samples*—Remove and discard a minimum of 25 m (25 yd) from the outside of the package before taking the sample or any specimens. If specimens are not taken directly from the original package, preferably wind the sample on a tube or spool by means of a winder using a tension of 5 ± 1 mN/tex (0.05 ± 0.01 gf/den). If the sample is collected as a loosely wound package, or in the form of a skein, some shrinkage invariably will occur, in which case, report that the observed results were determined on a relaxed sample. Use care in handling the sample. Discard any sample subjected to any change of twist, kinking, or making any bend with a diameter less than 10 times the yarn/cord thickness (or diameter). Place the sample in a moisture-proof polyethylene bag or other moisture-proof container to protect it from atmospheric changes until ready to condition the sample in the test atmosphere for industrial yarns and tire cords.

6.3 *Tire Cord Fabric:*

6.3.1 *Number of Samples and Specimens*—The sizes of an acceptance sampling lot of tire cord fabric shall be one loom creel of cord. Take a sample from at least one roll of fabric per lot. From each roll of tire cord fabric, take the number of specimens as specified in the test method for each property to be measured.

6.3.2 *Size of Sample*—Take a sample equal to the length of cord between the regular tabby woven at the end of the roll and a special tabby woven a short distance from the end when the roll of fabric is manufactured. For rolls that do not have a special woven tabby, improvise a tabby by the use of gummed

tape or strips of cemented fabric applied across a section of the cord fabric to give a tabby sample length at least 0.5-m (18-in.) long and at least one tenth of the roll width wide.

6.3.3 *Preparation of Samples*—Cut the warp cords of the fabric along the center line of the special tabby for a distance equal to the width of the sample. If this distance is less than the full width of the fabric, cut the filling yarns of the sample and of the special and regular tabbies in the direction parallel with the warp cords. The resulting section of cord fabric is the tabby sample. Attach the tabby sample to a piece of cardboard or fiberboard, the length of which shall be equal to at least the length of the cord warp between tabbies. Fold the tabby portions of the sample over each end of the board, and secure the sample to the board with pressure-sensitive tape or staples. Use care to avoid contact of tape or staples with the area to be tested. Handle the sample carefully, and hold it under sufficient tension in the warp direction to prevent the cords from kinking. Discard any specimen subjected to change of twist, kinking, or making any bend with a diameter less than 10 times the yarn/cord thickness (or diameter). The board with the sample may be folded lengthwise and parallel with the warp for convenience. Place the board with the fabric sample in a polyethylene bag, or wrap it with several layers of polyethylene film, to protect the sample from changes in atmospheric moisture content until ready to condition the sample in the atmosphere for testing industrial yarns and tire cords. Use care during subsequent handling of the sample to prevent any change in the cord twist and to avoid kinking the cords.

6.4 *Cord from Cured Tires:*

6.4.1 *Number of Samples and Specimens*—For each test, test ten cords from each location or ply of each tire.

6.4.2 *Preparation of Samples*—Obtain a tire section comprising approximately one sixth of the whole tire. Smaller sections may be used, particularly for carcass cord samples of radial tires. If it is suspected that cords may be damaged in pulling them from the tire, immerse the section in a solvent⁵ for 1 to 3 days to swell and soften the rubber. For convenience, turn the section inside out, if possible; clamp one of the beads in a vise. Mark a line along the inside of the section approximating the cord path of the first ply. Make a shallow cut down to the first ply along this line. Make an incision adjoining and perpendicular to this first cut at sufficient depth to sever several first-ply cords. Carefully cut and pull these cords from the tire from bead to bead following the cord path. Discard these initial cords. After initial cords are removed, remove bands of cords for testing by cutting near the bead through Ply 1 cords adjacent to the trough formed in initial cord removal. Carefully pull several cord bands approximately 2 cm ($3/4$ in.) in width from the tire. Identify bands, fully including tire number and ply number. Remove the remainder of Ply 1 to uncover Ply 2. Proceed with Ply 2 or additional plies as directed for Ply 1. If the cords to be removed are from a tire having only one ply of reinforcement in the area to be sampled, for example, carcass ply of many radial tires reinforced with glass, aramid, or steel, it is preferable to remove cords for

⁵ Heptane, 1,1,1-trichloroethane, and a mixture of 50/50 Freon 113 and Stoddard Solvent have been used for this purpose.

testing one at a time from the tire section itself. It is preferred that cord be removed in such a manner that it is not subjected to narrow-radius bending, such as a 3.14 rad (180°) bend back upon itself. This is accomplished by first removing and discarding a band of cords in the ply being sampled, then pulling the exposed cord at the edge of the ply (still in the tire section) by applying tension to this single cord as much within the plane of the ply as possible and in such a direction that the cord is subject to a bend of less than 1.05 rad (60°) at the tear point from its adjacent cord. The same principles just described also apply to areas of the tire (such as the tread) composed of multiple plies of high modulus cords.

6.4.3 Preparation of Specimens for Testing from a Ply Band—Make a cut approximately 20 mm (¾ in.) long between each cord at one end of the ply band. Strip every other cord from the band to a length sufficient for testing; leave a small unstripped cord portion attached to the band to facilitate handling. Cut individual ends from the band for testing.

6.4.3.1 Large variations in properties can occur within the same cord depending on its location within the tire. Select the location in the tire to be sampled and take a length of cord from this location for subsequent testing. Use a testing length appropriate for the length of the specimen to obtain data that reflect the relationship between the cord properties and the location in the tire.

7. Conditioning

7.1 Bring all specimens of yarn, cord, and fabric to moisture equilibrium for testing in the atmosphere for testing industrial yarns. Approach moisture equilibrium of rayon samples from the dry side, but not from a moisture-free condition.

7.1.1 The moisture equilibrium of conditioned aramid yarns and tire cords made from such yarns can be affected by heat and humidity conditions to which the samples have been previously exposed.

8. Identification of Fibers

8.1 Identify the common types of manufactured organic-base fibers as directed in Test Methods D 276.

9. Commercial Mass

9.1 Yarn—Determine the commercial mass of a yarn shipment as directed in Option II of Test Method D 2494. Take samples of yarn from the outside of beams unless there is a question or disagreement regarding a shipment; in this case, take a sample of yarn only after yarn has been removed from a beam to a radial depth of 6 mm (¼ in.) or more. Take a sample 15 to 20-m (15 to 20-yd) long, which is composed of all ends of yarn on the beam, and cut this sample crosswise to obtain two specimens of approximately equal mass. Place the specimens in moisture-proof polyethylene bags or other moisture-proof containers until ready to begin the analysis.

9.2 Cord and Tire Cord Fabric—Determine the commercial mass of tire cord and tire cord fabric as agreed upon between the purchaser and the supplier.

10. Moisture Regain, Actual

10.1 Scope—This test is used to determine the amount of moisture in yarn or cord at moisture equilibrium at the time of

testing for moisture dependent properties, such as tenacity and elongation.

10.2 Summary of Test Method—Specimens of yarn or cord, which are taken at the tensile testing machine at the time that tensile tests are being made, are weighed and dried in an oven until they reach a constant mass. The observed moisture loss is calculated and reported as percent regain.

10.3 Significance and Use—This test method is used not only to determine moisture regain of the original sample but is also used to develop data, which may be used to correct observed tensile properties of rayon yarns and cords to a standard regain basis. Because the moisture regain levels of different specimens vary even after conditioning in a test atmosphere and because tensile properties are affected by moisture regain, it is advisable to correct observed tensile values when there is substantial variation from a standard moisture regain level. Directions for making such corrections are included in Section 11 for Linear Density, Section 17 for Breaking Strength, and Section 20 for Elongation. It is assumed that no significant amount of nonaqueous volatile matter is present and that all loss in mass is moisture. If such materials are present, apply a suitable correction, or determine the true amount of moisture by the toluene distillation method as directed in Procedure 3 of Test Method D 2462.

10.4 Apparatus:

10.4.1 Oven—An oven with circulating air maintained at a temperature of 105 ± 3°C (221 ± 6°F) and with fresh air replacement rate of 20 to 50 times the oven-volume per hour, the fresh air being taken from the standard atmosphere of 24 ± 1°C (75 ± 2°F) and 55 ± 2 % RH. The air shall pass freely through and around the specimens. The specimens must not be subjected to direct radiation from the heating unit. The oven has to be large enough to handle the required number of spools or racks and has to be equipped with suitable removable creels for placing the spools or reels in the oven or with supports for the special mounting racks for the same purpose, or both. The oven may be combined with a balance, in which case the design must prevent disturbance of the balance due to circulating air during the weighing operation.

10.5 Preparation of Specimen—Take a single specimen of yarn or cord weighing at least 10 g from the original sample at the testing machine at the time that tensile properties are being determined (see Note 1). Place this specimen in a covered weighing bottle. Do not touch the specimen with the bare hands.

NOTE 1—The determination of moisture regain can be combined with the determination of linear density (Section 11) if the specimen is long enough to meet the length and mass tolerances and if the skein is exposed to the same atmosphere as the sample to be used for determination of tensile properties.

10.6 Procedure—Weigh the specimen to 0.01 g and dry it in the ventilated oven at a temperature of 105 ± 3°C (221 ± 6°F). Dry the specimen to constant mass, that is, until it loses no more than 0.1 % of its mass at 15-min intervals if weighed in the oven or at 30-min intervals if weighed outside the oven. For specimens that are weighed outside the oven, use a weighing bottle with tight-fitting cover, and cool the specimen and container to room temperature in a desiccator before weighing.

10.7 Calculation:

10.7.1 Calculate the moisture regain of the specimen using Eq 2:

$$MR = [(W - D)/D] \times 100 \quad (2)$$

where:

- MR = moisture regain, %,
- W = original mass of specimen, g, and
- D = oven-dried mass of specimen, g.

10.7.2 Calculate the average for the sample and use this value for determining the amount of adjustment to make in Sections 17 and 20 to the observed breaking force and elongation of yarn or cord.

10.8 Report:

10.8.1 State that the specimens were tested as described in Section 10 of Test Methods D 885. Describe the material or product sampled and the method of sampling used.

10.8.2 Report the average moisture regain for each sample.

10.9 Precision and Bias:

10.9.1 Precision—See Test Methods D 2654, Procedure 1.

10.9.2 Bias—See 39.3.

11. Linear Density

11.1 Scope—This test method is used to determine the linear density of yarn or cord for use in the calculation of tensile properties, such as modulus and tenacity.

11.2 Number of Specimens—Test five specimens of yarn or cord. This number is based on the assumption that the applicable coefficient of variation is 1.0 % and the allowable variation is 0.9 % of average with a probability level of 95 %.

11.3 Procedure for Yarn—Determine the linear density of yarn as directed in Option 1 of Test Method D 1907, except condition the yarn as specified in Section 7. Use Option 3 for rayon. If oven-dried and finish-free linear density is needed, use Option 5 or Option 6 with an allowance for moisture regain.

11.4 Procedure for Cord—Determine the linear density of cord on packages or removed from a tabby sample of fabric by the procedures prescribed as follows for either conditioned cords or oven-dried cords (see 11.4.2).

11.4.1 Preparation of Specimens—Take specimens having a minimum length of 10 m (10 yd) from samples of cord on cones, tubes, bobbins, or spools. For tabby samples of fabric, use a sufficient number of ends to give a minimum length of 10 m (10 yd) of cord for each specimen. Measure the length of the specimen to within 0.1 % while under a tension corresponding with 5 ± 1 mN/tex (0.05 ± 0.01 gf/den) (see Note 2). Weigh the conditioned specimen to the nearest 1 mg. If a balance of the required sensitivity (1 mg) for weighing the 10 m (10 yd) specimen is not available, take a longer specimen or multiple ends.

NOTE 2—When arbitration is not involved, an approximation of the specified tension may be obtained by applying one of the forces listed as follows for the specified groups of yarn and cord sizes:

Linear Density of Specimen	Amount of Force	
	N	gf
Below 400 tex (3600 denier)	1	100
400 to 600 tex (3600 to 5400 denier)	2	200
600 to 800 tex (5400 to 7200 denier)	3	300

Linear Density of Specimen	Amount of Force	
	N	gf
Above 800 tex (7200 denier)	4	400

11.4.2 Procedure for Oven-Dried Specimens—Using an oven with circulating air maintained at a temperature of $105 \pm 3^\circ\text{C}$ ($221 \pm 6^\circ\text{F}$) (see Section 10.4), dry the specimen to constant mass; that is, until it loses no more than 0.1 % of its mass at 15-min intervals if weighed to the nearest 1 mg in the oven or at 30-min intervals if weighed outside the oven. For specimens that are weighed outside the oven, use a weighing bottle with a tight-fitting cover and cool the specimen and container to room temperature in a desiccator before weighing. Weigh the specimen of the oven-dried cord to the nearest 1 mg.

11.4.3 Calculation—Calculate the linear density of each specimen in tex (denier) units using Eq 3, Eq 4, Eq 5, or Eq 6:

$$LD_{tc} = (1000 \times M_o \times K)/L_o \quad (3)$$

$$LD_{dc} = (9000 \times M_o \times K)/L_o \quad (4)$$

$$LD_{ta} = (1000 \times M_c)/L_o \quad (5)$$

$$LD_{da} = (9000 \times M_c)/L_o \quad (6)$$

where:

- LD_{tc} = linear density at commercial moisture regain, tex,
- LD_{dc} = linear density at commercial moisture regain, denier,
- LD_{ta} = linear density at actual moisture regain, tex,
- LD_{da} = linear density at actual moisture regain, denier,
- M_o = mass of oven-dried specimen, g,
- M_c = mass of conditioned specimen, g,
- L_o = length of specimen, m ($\text{yd} \div 1.09$ or $\text{yd} \times 0.918$), and
- K = factor for commercial moisture regain.

11.4.3.1 Determine the factor K using Eq 7:

$$K = (100 + CMR)/100 \quad (7)$$

where:

- CMR = commercial moisture regain, %.

For the commercial moisture regain, see Table 1. See also Table D 1909.

Example for rayon:

$$K = (100 + 11)/100 = 1.11 \quad (8)$$

11.4.3.2 For dipped cord, correct the observed linear density for dip solids pickup using Eq 9, Eq 10, or Eq 11. The oven-dried linear density should be corrected for dip solids pickup, not the conditioned linear density. For fibers with low percentage moisture regain, Eq 10 can be used with no correction for moisture regain.

$$LD_{dp} = [100/(100 + DPU)] + (MR_{dc}/100)] \times [100/(100 + MR_{dc})] \times LD_{dc} \quad (9)$$

TABLE 1 Commercial Moisture Regains of Manufactured Fibers Used in Tire Cords^A

	%
Rayon	11.0
Nylon	4.5
Polyester	0.4
Aramid	7.0

^ACommercial moisture regain of fibers not listed in this table shall be as agreed upon between the purchaser and the supplier or as in Table D1909.

$$LD_{dp} = [(LD_{dc} \times 100)/(100 + DPU)] \quad (10)$$

$$LD_{dpmr} = [(100 + MR_{gc})/100] \times [100/(100 + MR_{dc})] \times [(100 \times LD_{dc})/(DPU/(100 + DPU))] \quad (11)$$

where:

- LD_{dp} = linear density corrected for dip pickup, tex (denier),
- LD_{dpmr} = linear density corrected for dip pickup and moisture regain, tex (denier),
- LD_{dc} = observed linear density of dipped cord, tex (denier),
- DPU = percentage dip pickup, % (see Section 35),
- MR_{gc} = percentage commercial moisture regain of greige cord, %, and
- MR_{dc} = percentage moisture regain of dipped cord, %.

11.4.4 *Report:*

11.4.4.1 State that the specimens were tested as directed in Section 11 of Test Methods D 885. Describe the material or product sampled and the method of sampling used.

11.4.4.2 Report the option or procedure used, the number of specimens tested, and the average linear density.

11.4.4.3 Report the basis on which linear density is being reported (for greige, dipped, and so forth.).

11.4.5 *Precision and Bias:*

11.4.5.1 *Precision*—See Section 39.

11.4.5.2 *Bias*—See 39.3.

TENSILE PROPERTIES OF YARNS AND CORDS

12. Scope

12.1 These test methods are used to determine the tensile properties of yarns or cords.

13. Summary of Test Method

13.1 A conditioned or oven-dried specimen of yarn or cord is clamped in a tensile testing machine and then stretched or loaded until broken. Breaking force, elongation, and force at specified elongation (FASE) are determined directly. Modulus and work-to-break are calculated from the force-elongation curve. The output of a constant-rate-of-extension (CRE) tensile testing machine can be connected with electronic recording and computing equipment, which may be programmed to calculate and print the test results of tensile properties of interest.

14. Significance and Use, Tensile Properties

14.1 The levels of tensile properties obtained when testing industrial yarns and tire cords are dependent to a certain extent on the age and history of the specimen and on the specific conditions used during the test. Among these conditions are rate of stretching, type of clamps, gage length of specimen, temperature and humidity of the atmosphere, rate of airflow across the specimen, and temperature and moisture content of the specimen. The relative importance of these factors varies with each type of fiber. Testing conditions accordingly are specified precisely to obtain reproducible test results on a specific sample.

14.2 Because the force-bearing ability of a reinforced rubber product is related to the strength of the yarn or cord used as a reinforcing material, *breaking strength* is used in engineering calculations when designing various types of textile rein-

forced rubber products. When needed to compare intrinsic strength characteristics of yarns or cords of different sizes or different types of fiber, *breaking tenacity* is very useful because, for a given type of fiber, breaking force is approximately proportional to linear density.

14.3 *Elongation* of yarn or cord is taken into consideration in the design and engineering of reinforced rubber products because of its effect on uniformity of the finished product and its dimensional stability during service.

14.4 The *FASE* is used to monitor changes in characteristics of the textile material during the various stages involved in the processing and incorporation of yarn or cord into a rubber product.

14.5 *Modulus* is a measure of the resistance of yarn or cord to extension as a force is applied. It is useful for estimating the response of a textile reinforced structure to the application of varying forces and rates of stretching. Although modulus may be determined at any specified force, initial modulus is the value most commonly used.

14.6 *Work-to-break* is dependent on the relationship of force to elongation. It is a measure of the ability of a textile structure to absorb mechanical energy. *Breaking toughness* is work-to-break per unit mass.

14.7 It should be emphasized that, although the preceding parameters are related to the performance of a textile-reinforced product, the actual configuration of the product is significant. Shape, size, and internal construction also can have appreciable effect on product performance. It is not possible, therefore, to evaluate the performance of a textile reinforced product in terms of the reinforcing material alone.

15. Apparatus

15.1 *Tensile Testing Machine*—A single-strand tensile testing machine of one of the following types:

Type	Principle of Operation
CRE	constant-rate-of-specimen extension
CRL	constant-rate-of-loading (inclined plane type)
CRT	constant-rate-of-transverse (pendulum type)

The specifications and methods of calibration and verification of these machines shall conform to Specification D 76. The testing machine shall be equipped with an autographic recorder (rectilinear coordinates preferred) and clamps of the cam or pneumatic type having fixed snubbing surfaces, that are integral with one of the clamping surfaces. The snubbing surfaces may be circular with a diameter of not less than 12.5 mm (1/2 in.) or semi-involute. It is also permissible to use tensile testing machines that have a means for calculating and displaying the required results without the use of an autographic recorder. CRE-type tensile testing machines are the preferred type of test equipment to be used. Correlation of results from CRL- and CRT-type tensile testing machines with results from CRE-type tensile testing machines is poor, and a bias determination must be made. For tensile testing of aramid fibers, the CRL- and CRT-types of tensile testing machines are considered to be not suitable and are not recommended.

15.1.1 *CRE-Type Tensile Testing Machines*—For all fiber types, except aramid fibers, use a crosshead travel rate in mm/min (in./min) of 120 % (100 % alternate) of the nominal

gage length in millimetres (inches) of the specimen. For aramid fibers use a crosshead travel rate in mm/min (in./min) of 50 % of the nominal gage length in millimetres (inches) of the specimen.

15.1.2 *CRL-Type Tensile Testing Machines*—Use the following rates of loading:

For rayon	25 ± 3 (mN/tex)/s (18 ± 2 (gf/den)/min)
For nylon and polyester	50 ± 7 (mN/tex)/s (35 ± 5 (gf/den)/min)

15.1.3 *CRT-Type Tensile Testing Machines*—For all fiber types, except aramids, use a rate of traverse in mm/min (in./min) of 120 % (100 % alternate) of the nominal gage length in millimetres (inches) of the specimen.

16. Breaking Strength (Force) of Conditioned Yarns and Cords

16.1 *Scope*—This test method is used to determine the breaking strength (force) of yarns and cords after conditioning in the atmosphere for testing industrial yarns and tire cords.

16.2 *Number of Specimens*—Test ten specimens. This number is based on the data for cords in Table 2, which shows precision to be expected at the probability level of 95 % based on ten breaks from a single test spool of cord of each polymer type on various cords.

16.3 *Procedure*—Select a loading cell and the settings of the tensile tester such that the estimated breaking force of the specimen will fall in the range from 10 to 90 % of the full-scale force effective at the time of the specimen break. This selection of the full scale force may be done manually by the operator before the start of the test or by electronic means or computer control during the test by automatically adjusting the amplification of the loading cell amplifier. Adjust the distance between the clamps on the testing machine so that the nominal gage length of the specimen, measured from nip to nip of the jaws of the clamps, is 250 ± 1 mm (10 ± 0.05 in.) (alternate 500 ± 2 mm (20 ± 0.10 in.)). Make all tests on the conditioned yarns and cords in the atmosphere for testing industrial yarns and tire cords (Note 3, Note 4, and Note 5 provide useful information in obtaining more consistent results in tensile testing). Remove the specimen from the sample and handle it to prevent any change in twist prior to closing the jaws of the clamps on the specimen. For essentially zero twist yarns, refer to Note 5. Do not touch that portion of the specimen that will be between the clamps with bare hands. Depending on the equipment being used and the availability of on-line computer control and data processing, either can be used:

pretension-start procedure (see 16.3.1) or
slack start procedure (see 16.3.2).

16.3.1 *Pretension-Start Procedure*—Use a tensioning device that applies a pretension corresponding to 20 ± 1 mN/tex (0.20 ± 0.01 gf/den) for aramid fibers; use 5 ± 1 mN/tex (0.05 ± 0.01 gf/den) for all other fibers (see Note 3 and Note 4). This device may be a weight, a spring, or an air-actuated mechanism. Thread one end of the specimen between the jaws of the clamp connected to the loading cell and close it. Place the other end through the jaw of the second clamp and fix a pretension weight to the unclamped end or pull the thread such that the specified pretension in the test specimen is applied. Close the second clamp and operate the testing machine at the rate

specified in 15.1. When the specimen breaks (ruptures), read the breaking force (maximum force) in newtons (pounds-force) from the force-elongation (or force-extension) curve on the chart, from the dial, from the display, or by electronic means. Discard specimens that break in the jaws or within 10 mm (1/8 in.) of the nip of the jaws. If the clamps are of the air-actuated type, adjust the air pressure so that specimens will not slip in the jaws, but keep air pressure below the level that will cause specimens to break at the edge of the jaws.

NOTE 3—When arbitration of test data is involved, use care in the application of the pretension force that may be specified because the actual pretension in the specimen commonly is different from the amount applied externally because of losses due to friction in the clamp. Check the pretension before starting the testing machine. The actual pretension can be measured by strain gages. Other tension-measuring instruments with sufficient accuracy may be used, provided that the specimen is threaded through the instrument prior to being placed in the second clamp. This procedure is necessary because many instruments require appreciable displacement of the specimen.

NOTE 4—When arbitration is not involved, one of the following approximations of the specified pretension may be used. Either exert a force of 120 % of the nominal pretension to the unclamped end of the specimen prior to closing the second grip, or apply one of the forces listed as follows for the specified groups of yarn and cord sizes to secure the necessary pretension.

Linear Density of Specimen	Amount of Force	
	N	gf
Below 400 tex (3600 denier)	1	100
400 to 600 tex (3600 to 5400 denier)	2	200
600 to 800 tex (5400 to 7200 denier)	3	300
Above 800 tex (7200 denier)	4	400

When using a CRE-type tensile machine, a third technique is to close the upper clamp, then apply pretension by pulling on the specimen until the recorder pen moves approximately 1/2 chart division from the zero line on the chart when using a force scale that is the same as that used for determining the breaking force.

16.3.2 *Slack Start Procedure*—Thread one end of the specimen between the jaws of one of the clamps and close it. Place the other end of the specimen through the jaws of the second clamp and keep the specimen just slack (zero tension) and close the clamp, taking care that the thread is positioned in the centerline of the jaws of the clamp. Operate the testing machine at the rate as specified in 15.1 and stretch the specimen until it ruptures. When the specimen breaks, read the breaking force (maximum force) in newtons (pounds-force) from the force-elongation curve, from the dial, from the display, or by electronic means. Discard specimens that break in the jaws or within 10 mm (1/8 in.) of the nip of the jaws. If the clamps are of the air-actuated type, adjust the air pressure to prevent specimens slipping in the jaws, but keep the air pressure below the level that will cause specimens to break at the edge of the jaws. This slack start procedure has the effect that the nominal gage length of the specimen is not exactly 250 (or 500) mm (10 (or 20) in.) as specified in 16.3, but always will be somewhat more due to slack in the specimen after closing the clamps.

NOTE 5—Because of the difficulty of securing the same tension in all the filaments and because of slippage in the clamps, variable results may be obtained when testing zero-twist multifilament yarns unless a small amount of twist is inserted prior to testing. A twist of 60 t/m (1.5 tpi) inserted into zero-twist yarns of different sizes has been found satisfactory

TABLE 2 Critical Differences, Expressed as Percent of Observed Average (Except as Noted)^{A,B}

Property Measured	Number of Observations in Each Average	Critical Differences	
		Single-Operator Precision	Between-Laboratory Precision
<i>Table 4a 840/2 Nylon Cord (12 × 12 twist):^C</i>			
Breaking strength, lbf	10	1.41	4.57
Elongation at break, %	10	4.50	13.60
Load at specified elongation (LASE) (reported at 14 % E), lbf	10	4.97	20.70
Modulus, gf/den	10	5.05	8.31
Work-to-break, in.·lbf/in.	10	6.69	10.41
Thickness of cords, mils	10	0.56 ^D	1.46 ^D
Twist, tpi: Cord	10	0.27 ^D	0.43 ^D
Singles	10	0.12 ^D	0.25
Linear density, den: ^C			
From bobbin	5	1.07	4.49
From tabby	5	0.40	4.54
<i>Table 4b 1000/3 Polyester Cord (10 × 10 twist):</i>			
Breaking Strength, lbf	10	1.72	4.65
Elongation at break, %	10	2.66	9.95
Load at specified elongation (LASE) (reported at 10 % E), lbf	10	5.15	5.59
Modulus, gf/den	10	4.75	4.75
Work-to-break, in.·lbf/in.	10	4.83	16.07
Thickness of cords, mils	10	0.52 ^D	0.52 ^D
Twist, tpi: Cord	10	0.21 ^D	0.47 ^D
Singles	10	0.11 ^D	0.29 ^D
Linear density, den:			
From bobbin	5	0.47	1.86
From tabby	5	0.65	2.83
<i>Table 4c 1650/3 Rayon Cord (11 × 10 twist):^E</i>			
Breaking strength, lbf	10	2.73	5.62
Elongation at break, %	10	3.04	6.49
Load at Specified Elongation (LASE) (reported at 6 % E), lbf	10	4.67	19.20
Thickness of cords, mils	10	0.66 ^D	2.07 ^D
Twist, tpi: Cord	10	0.24 ^D	0.51 ^D
Singles	10	0.14 ^D	0.30 ^D
Linear density, den:			
From bobbin	5	0.37	2.98
From tabby	5	0.41	1.58
<i>Table 4d 1500/2 High-Modulus Aramid Cord (4 × 4 twist):</i>			
Breaking strength, lbf	10	1.06	6.68
Elongation at Break, %	10	2.26	20.80
Modulus, gf/den	10	3.22	19.69
Work-to-break, in.·lbf/in.	10	3.89	48.99
Thickness of cords, mils	10	0.77 ^D	10.73 ^D
Twist, tpi: Cord	10	0.09 ^D	0.34 ^D
Singles	10	0.09 ^D	0.24 ^D
<i>Table 4e 1500/2 High-Modulus Aramid Cord (7.5 × 7.5 twist):</i>			
Breaking strength, lbf	10	2.11	9.79
Elongation at break, %	10	2.18	26.70
Modulus, gf/den	10	2.13	35.43
Work-to-break, in.·lbf/in.	10	8.41	43.77
Thickness of cords, mils	10	0.77 ^D	8.49 ^D
Twist, tpi: Cord	10	0.09 ^D	0.40 ^D
Singles	10	0.09 ^D	0.56 ^D
Load at specified elongation (LASE) without Rosin (reported at 2 % E), lbf.	10	1.12	13.00
<i>Table 4f 1500/1 High-Modulus Aramid Yarn:</i>			
Breaking strength, lbf	10	1.33	9.46
Elongation at break, %	10	2.55	23.39
Modulus, gf/den	10	4.43	14.68

^AThe critical differences were calculated using $t = 1.960$ which is based on infinite degrees of freedom.

^BTo convert the values of the critical difference expressed as a percent of the grand average to units of measure, multiply the average of the two specific sets of data being compared by the critical differences expressed as a decimal fraction.

^C1260/2 nylon cord for linear density.

^DProperties noted in this table have critical differences in the units shown rather than as a percent of the grand average.

^ERayon data, except thickness, twist, and linear density, are for oven-dry cord.

for the purpose of tensile testing. Historically, twist up to 120 t/m (3.0 tpi) have been used in some cases. For aramid yarns the amount of twist to be inserted shall be calculated using Eq 12 and Eq 13:

$$T_{ipm} = (1055 \pm 50) / \sqrt{(LD)_i} \quad (12)$$

where:
 T_{ipm} = twist, tpm,

$$T_{ipi} = (80.3 \pm 4) / \sqrt{(LD)_i} \quad (13)$$

T_{ipi} = twist, tpi,
 LD_t = linear density, tex, and
 LD_d = linear density, denier.

Inserting some twist in zero-twist yarns for tensile testing has the following effects on the test results:

- modestly increases breaking force; too much twist reduces breaking force,
- increases elongation at break, and
- reduces modulus (the slope of the force-elongation curve).

Manner of inserting the twist into the yarn, manually or with a twisting machine, can influence the test results, especially for the aramid yarns.

16.3.3 The velocity of conditioned air flowing across a specimen while determining tensile properties can have a measurable effect on the breaking force and elongation at break because of the Gough-Joule effect. The magnitude of this effect depends on the type of fiber, air velocity, and sample history. Interlaboratory testing of nylon, polyester, and rayon cords indicates that air velocities of less than 250 mm/s (50 ft/min) across the specimen will not significantly bias the comparison of cord properties between laboratories.⁶

16.3.4 As diameters and strengths of cords increase, clamps with larger snubbing surfaces and greater holding power or capacity may be required to prevent slippage of cords in testing machine clamps or an excessive number of jaw breaks. The levels of cord size and strength at which such higher capacity clamps are required must be determined by experiment because they will vary with the type of fiber and construction. Some clamps with larger snubbing surfaces and greater holding power or capacity may be too large to allow a 250 or 500-mm (10 or 20-in.) gage length. In those cases, use the appropriate gage length for the clamp in use. If slippage of cords cannot be prevented with the highest capacity clamps available to the user, it has been found useful to apply powdered rosin to the two portions of the cord that will be held between the snubbing surfaces. Use of rosin has been found particularly useful in testing organic cords that have been adhesive treated.

16.4 *Calculation*—Calculate the average breaking force from the observed breaking forces of specimens read from the testing machine chart or dial to the nearest 0.5 N (0.1 lbf).

16.5 Report:

16.5.1 State that the specimens were tested as directed in Section 16 of Test Methods D 885. Describe the material or product sampled and the method of sampling used.

16.5.2 Report the option or procedure used; the number of specimens tested; the amount of twist, if any, inserted into the yarn for the tensile testing; and the breaking force for the sample as the breaking strength.

16.6 Precision and Bias:

16.6.1 *Precision*—See Section 39.

16.6.2 *Bias*—See 39.3.

17. Adjustment of Observed Breaking Strength (Force) of Rayon Yarns and Cords to a Specified Moisture Regain Level

17.1 *Scope*—This test method is used to adjust the observed breaking strength (force) of rayon yarns and cords to a specified moisture regain level.

17.2 *Calculation*—If the moisture regain of a rayon sample at the time of testing is within $\pm 0.3\%$ of the regain level specification, report the average observed breaking force as the breaking strength. If the moisture regain is outside the $\pm 0.3\%$ limit, adjust the observed breaking strength to the specification regain basis using a suitable adjustment factor. Establish this factor for a specific material by making breaking tests at a sufficient number of different moisture regain levels to determine the slope of the “breaking strength (force) versus moisture regain” curve. Apply the factor using Eq 14:

$$BS = BF \times F \quad (14)$$

where:

BS = breaking strength, adjusted to specification moisture regain level, N (lbf),

BF = observed average breaking force, N (lbf), and

F = factor for adjusting observed breaking forces to a specified moisture regain level.

18. Breaking Tenacity of Conditioned Yarns and Cords

18.1 *Scope*—This test method is used to determine the breaking tenacity of yarns and cords after conditioning in the atmosphere for testing industrial yarns and tire cords.

18.2 *Calculation*—Calculate the breaking tenacity of the sample in terms of millinewtons per tex (mN/tex) (grams-force per denier (gf/den)) from the breaking strength and the linear density using Eq 15 and Eq 16:

$$BT_n = (BF_n \times 1000 / LD_t) \quad (15)$$

$$BT_g = (BF_l \times 454 / LD_d) \quad (16)$$

where:

BT_n = breaking tenacity, mN/tex,

BT_g = breaking tenacity, gf/den,

BF_n = average breaking force, N,

BF_l = average breaking force, lbf,

LD_t = measured linear density, tex, and

LD_d = measured linear density, denier.

18.3 Report:

18.3.1 State that the specimens were tested as directed in Section 18 of Test Method D 885. Describe the material or product sampled and the method of sampling used.

18.3.2 Report the option or procedure used, the number of specimens tested, and the breaking tenacity for the sample.

18.4 Precision and Bias:

18.4.1 *Precision*—See Section 39.

18.4.2 *Bias*—See 39.3.

19. Elongation at Break of Conditioned Yarns and Cords

19.1 *Scope*—This test method is used to determine the elongation at break of yarns and cords after conditioning in the atmosphere for testing industrial yarns and tire cords.

19.2 *Procedure*—Determine the elongation at break of each conditioned specimen when determining its breaking force (see Section 16). Read the extension at the breaking force from the autographic recorder or by electronic means. The general equation for elongation at break is given in Eq 17:

$$EB = (E_b / L_o) \times 100 \quad (17)$$

⁶ See Jones, R. E., and Desson, M. J., “Adiabatic Effects on Tensile Testing,” *Journal of the I.R.I.*, June 1967.

where:

- EB = elongation at break, %,
- E_{bf} = extension of specimen at the breaking force, mm (in.), and
- L_o = length of the specimen, under specified pretension measured from nip-to-nip of the holding clamps, mm (in.).

19.2.1 Pretension Start—Use Eq 17.

19.2.2 Slack Start—Calculate the gage length (L_o) to include the slack using Eq 18:

$$L_o = L_s + DP \quad (18)$$

where:

- L_o = length of the specimen, under specified pretension, measured from nip-to-nip of the holding clamps, mm (in.),
- L_s = gage length after clamping specimen (absolute distance nip-to-nip before movement of crosshead), mm (in.), and
- DP = displacement of crosshead to reach the specified pretension of the specimen (see Fig. 1), mm (in.).

The pretension for aramid corresponds with 20 ± 1 mN/tex (0.20 ± 0.01 gf/den) and for other yarns and cord to 5 ± 1 mN/tex (0.05 ± 0.01 gf/den).

The general equation for elongation at break for the slack start procedure is given in Eq 19:

$$EB = [E_{bf}/(L_s + DP)] * 100 \quad (19)$$

where:

- EB = elongation at break, %,
- E_{bf} = extension of specimen at the breaking force, mm (in.),
- L_s = gage length after clamping specimen (absolute distance nip-to-nip before movement of crosshead), mm (in.), and
- DP = displacement of crosshead to reach the specified pretension of the specimen (see Fig. 1), mm (in.).

19.2.3 Elongation also may be determined from the force-elongation curve at any force.

19.3 Calculation—Calculate the average elongation of the sample to the nearest 0.1 %.

19.4 Report:

19.4.1 State that the specimens were tested as directed in Section 19 of Test Method D 885. Describe the material or product sampled and the method of sampling used.

19.4.2 Report the option or procedure used, the number of specimens tested, and the elongation for the sample.

19.5 Precision and Bias:

19.5.1 Precision—See Section 39.

19.5.2 Bias—See 39.3.

20. Adjustment of Observed Elongation of Rayon Yarns and Cords to a Specified Moisture Regain Level

20.1 Scope—This test method is used to adjust the observed elongation of rayon yarns and cords to a specified moisture regain level.

20.2 Procedure—If the moisture regain of a rayon specimen at the time of testing is within ± 0.3 % of the regain level specification, report the average observed elongation at break. If the moisture regain is outside the ± 0.3 % limit, adjust the observed elongation to the specification regain basis using a suitable adjustment factor. Establish this factor for a specific material by making elongation tests at a sufficient number of different moisture regain levels to determine the slope of the “elongation at break versus regain” curve. Apply the factor using Eq 20:

$$E_a = E \times F \quad (20)$$

where:

- E_a = elongation, adjusted to specification moisture regain level, %,
- E = observed elongation, %, and
- F = factor for adjusting observed elongation to an elongation at specification moisture regain level.

21. Force at Specified Elongation (FASE) of Conditioned Yarns and Cords

21.1 Scope—This test method is used to determine the force at specified elongation (FASE) of yarns and cords after conditioning in the atmosphere for testing industrial yarns and tire cords.

21.2 Procedure:

21.2.1 Nylon, Polyester, Rayon, and Aramid Yarns and Cords—Determine the force at specified elongation (FASE) of each conditioned specimen when determining its breaking force (see Section 16 and Fig. 1). Read the force directly from the force-extension curve (see Fig. 1) or by electronic means or

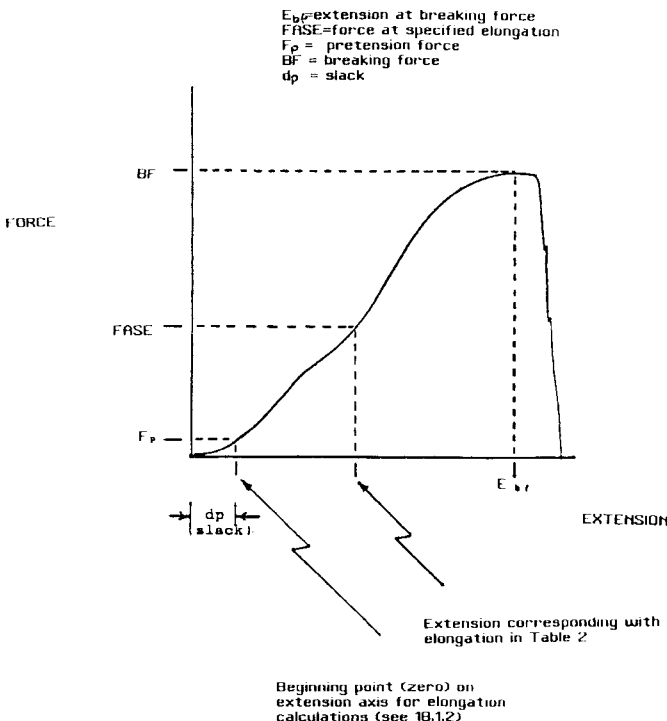

FIG. 1 Force-Extension Curve

with an on-line computer at the specified value of elongation for the fiber types listed in Table 3.

21.2.1.1 Assure that the displacement (DP) of the crosshead to remove slack is taken into account when using slack start procedure. Follow same general procedure as for elongation at break (see section 19.1.2 and Fig. 1).

21.2.1.2 Use Eq 21 in the case of slack start procedure to locate extension corresponding to specified elongation. Extension is measured from the pretension point (see Fig. 1), where the slack is removed from the specimen.

$$E_x = E_s \times (L_s + DP)/100 \quad (21)$$

where:

E_x = extension, mm (in.),

E_s = specified elongation, %,

L_s = gage length after clamping specimen (absolute distance nip-to-nip before movement of crosshead), mm (in.), and

DP = displacement of crosshead to reach the specified pretension of the specimen (see Fig. 1), mm (in.).

21.2.1.2.1 Read force, N (lbf), corresponding to above extension from the ordinate of the force-extension curve.

21.3 Calculation—Calculate the average FASE of the sample to the nearest 0.5 N (0.1 lbf).

21.4 Report:

21.4.1 State that the specimens were tested as directed in Section 21 of Test Methods D 885. Describe the material or product sampled and the method of sampling used.

21.4.2 Report the option or procedure used, the number of specimens tested, and the FASE for the sample.

21.5 Precision and Bias:

21.5.1 Precision—See Section 39.

21.5.2 Bias—See 39.3.

22. Modulus of Conditioned Yarns and Cords

22.1 Initial Modulus:

22.1.1 Scope—This test method is used to determine the initial modulus of yarns and cords after conditioning in the atmosphere for testing industrial yarns and tire cords.

22.1.2 Procedure:

22.1.2.1 Nylon, Polyester, or Rayon Yarns and Cords—Determine the initial modulus of each conditioned specimen when determining its breaking force (see Section 16). Using the force-elongation curve (see Fig. 2), draw a tangent to the initial straight-line portion of the curve. Extend this tangent to the abscissa (elongation axis), and upwards to a point that corresponds to slightly more than 10 % elongation. On the abscissa, measure and mark a distance equal to 10 % elongation of the specimen gage length beginning at the point of intersection of the tangent with the abscissa. At the 10 % mark, draw a line perpendicular to the abscissa and extend it upwards

F = force corresponding with 10% elongation

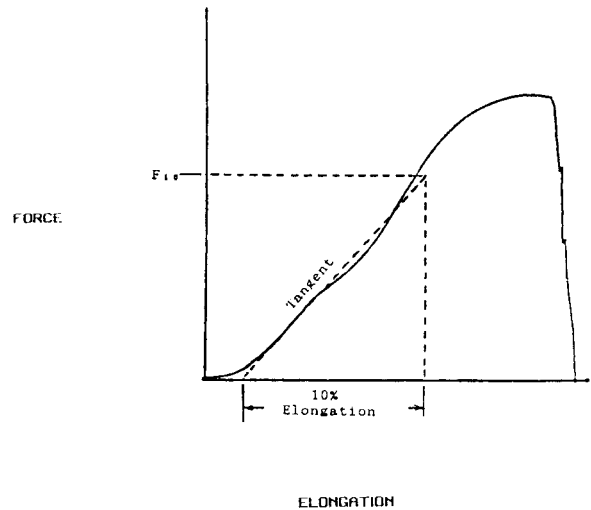

FIG. 2 Force-Elongation Curve for the Determination of Initial Modulus

until it intersects the tangent to the curve. This point represents the force required for 10 % elongation of the specimen at the rate represented by the straight line portion of the force-elongation curve. When electronic means are used, determine the modulus of the initial straight-line portion of the above curve. Calculate the modulus of a specimen, to the nearest 10 mN/tex (0.1 gf/den) using Eq 22 and Eq 23:

$$M_{in} = (10^4 \times F_{10n})/LD_t \quad (22)$$

$$M_{ig} = (4560 \times F_{10g})/LD_d \quad (23)$$

where:

M_{in} = initial modulus, mN/tex,

M_{ig} = initial modulus, gf/den,

F_{10n} = force at 10 % elongation, N,

F_{10g} = force at 10 % elongation, lbf,

LD_t = nominal linear density, tex (using Option 1 of Test Method D 1907), and

LD_d = nominal linear density, denier (using Option 1 of Test Method D 1907).

22.1.2.1.1 The CRL- and CRT-type tensile testing machines are not suited for modulus measurements; both types of testers tend to distort the slope of the force-elongation curve and do not guarantee the required accuracy for these tests.

22.1.2.2 Chord-Modulus Yarns and Cords—Determine the chord modulus of each conditioned specimen from the force-elongation curve (see Fig. 3). Determine the chord modulus between the points A and B as specified in Table 4. Locate the points A and B on the ordinate at the forces equivalent to A mN/tex (gf/den) and B mN/tex (gf/den) respectively. Draw from each of these two points respectively a line perpendicular to the ordinate to the intersection with the force-elongation curve. From these intersection points determine the related elongation values by drawing perpendicular lines to the abscissa.

22.1.2.2.1 Calculate the chord modulus of a specimen using Eq 24:

$$M_c = 100 \times (T_b - T_a)/(E_b - E_a) \quad (24)$$

TABLE 3 Elongation Values for Determination of FASE

Type of Fiber	Greige	Adhesive Processed Cord
Rayon	6	3
Nylon	14	5
Polyester	10	5
Aramid	2	1

FORCE-ELONGATION CURVE FOR THE DETERMINATION OF CHORD MODULUS

$F_{a,b}$ = forces corresponding to specified tenacity in table 6
 $E_{a,b}$ = elongation points corresponding to forces F_a & F_b

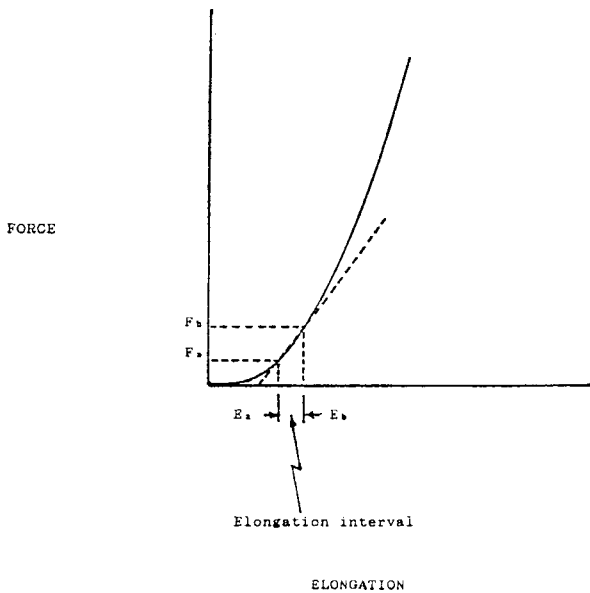

FIG. 3 Force-Elongation Curve for the Determination of Chord Modulus

TABLE 4 Lower and Upper Limit of the Chord Modulus Interval for the Different Types of Fibers

Type of Fiber	Lower Limit, T_a		Upper Limit, T_b	
	mN/tex	gf/den	mN/tex	gf/den
Rayon	30	0.3	60	0.6
Nylon	20	0.2	40	0.4
Polyester	30	0.3	60	0.6
Aramid	300	3.0	400	4.0

where:

- M_c = chord modulus, mN/tex (gf/den),
- T_b = upper limit in mN/tex (gf/den),
- T_a = lower limit in mN/tex (gf/den),
- E_b = elongation corresponding to T_b , % and
- E_a = elongation corresponding to T_a , %.

22.1.3 *Calculation*—Calculate the average initial modulus or the average chord modulus, or both, of the sample to the nearest 10 mN/tex (0.1 gf/den).

22.1.4 *Report:*

22.1.4.1 State that the specimens were tested as directed in Section 22 of Test Methods D 885. Describe the material or product sampled and the method of sampling used.

22.1.4.2 Report the option or procedure used for measuring the linear density, the number of specimens tested, and the initial modulus or the chord modulus, or both, for the sample.

22.1.5 *Precision and Bias:*

22.1.5.1 *Precision*—See Section 39.

22.1.5.2 *Bias*—See 39.3.

23. Breaking Strength (Force) of Oven-Dried Rayon Yarns and Cords

23.1 *Scope*—This test method is used to determine the

breaking strength of oven-dried rayon yarns and cords.

23.2 *Apparatus*—In addition to the tensile testing machine (see Section 15), the following accessory equipment is required:

23.2.1 *Sample Holder*—Use a yarn/cord support that will allow for tension-free contraction of the sample during the drying (for example, for continuous length samples, a collapsible spool or reel, or a tapered spool, and for short specimens as from a tabby sample, a special mounting rack). The holder must be of a suitable design to prevent any change in twist or any buckling or crinkling or stretching of the specimen during handling and drying and to facilitate rapid removal of the specimen from the oven for testing.

23.2.2 *Oven*—An oven with circulating air maintained at a temperature of $105 \pm 3^\circ\text{C}$ ($221 \pm 6^\circ\text{F}$) and with a fresh air replacement rate from 20 to 50 times the oven-volume per hour, the fresh air being taken from the standard atmosphere of $24 \pm 1^\circ\text{C}$ ($75 \pm 2^\circ\text{F}$) and $55 \pm 2\%$ RH. The air shall pass freely through and around the specimens. The specimens must not be subjected to direct radiation from the heating unit. The oven has to be large enough to handle the required number of spools or racks and has to be equipped with suitable removable creels for placing the spools or reels in the oven or with supports for the special mounting racks for the same purpose, or both.

23.3 *Preparation of Specimens*—For the drying process, mount the yarn or cord without stretching, buckling or crinkling and without any change of twist on the yarn/cord support (see Section 23.2.1), which allows the specimen to contract during the drying. Dry the sample(s) at $105 \pm 3^\circ\text{C}$ ($221 \pm 6^\circ\text{F}$) for a sufficient length of time (for at least 2 h, but no longer than 6 h) so that the loss in mass on heating for an additional 15-min period is less than 0.1 % of the original mass of the sample. After drying, test the specimens in the tensile testing machine directly from the oven and start the tester 10 ± 1 s after the specimen leaves the oven. While moving the specimen from the oven to the tensile testing machine, avoid any stretch, buckling, crinkling, or change of twist of the specimen. Do not touch with bare hands that portion of specimen that will be between the clamps of the tensile testing machine.

23.4 *Procedure*—Place the oven with the samples in a convenient position at the tensile testing machine so that in a rapid way the specimen can be taken out of the oven and can be mounted in the prescribed way in the clamps of the testing machine (see 16.3). Take all the precautions mentioned in 23.3. Make sure that the specimen being tested has been in the laboratory ambient atmosphere for just 10 ± 1 s at the moment the tensile tester is started. Determine the breaking force as directed in 16.3.

23.5 *Calculation*—Calculate the average breaking force of the oven-dried sample from the observed breaking force of the specimens read from the testing machine chart or dial to the nearest 0.5 N (0.05 gf/den).

23.6 *Report:*

23.6.1 State that the specimens were tested as directed in Section 23 of Test Methods D 885. Describe the material or product sampled and the method of sampling used.

23.6.2 Report the option or procedure used, the number of

specimens tested, and the breaking force for the oven-dried sample.

23.7 *Precision and Bias:*

23.7.1 *Precision*—See Section 39.

23.7.2 *Bias*—See 39.3.

24. Breaking Tenacity of Oven-Dried Rayon Yarns and Cords

24.1 *Scope*—This test method is used to determine the breaking tenacity of oven-dried rayon yarns and cords.

24.2 *Calculation and Report*—Calculate and report the breaking tenacity of the oven-dried rayon sample as directed in Section 18 using the average breaking force in newtons (pounds-force) of the oven-dried sample and the linear density based on the commercial regain (see Section 11).

25. Elongation at Break of Oven-Dried Rayon Yarns and Cords

25.1 *Scope*—This test method is used to determine the elongation at break of oven-dried rayon yarns and cords.

25.2 *Procedure*—Determine the elongation at break of each oven-dried specimen when determining its breaking force (see 23.4). Read the elongation from the autographic recorder chart, or by electronic means, at the breaking force. Express the observed elongation of each oven-dried specimen as a percentage of its nominal gage length.

25.3 *Calculation*—Calculate the average elongation at break for the sample to the nearest 0.1 %.

25.4 *Report:*

25.4.1 State that the specimens were tested as directed in Section 25 of Test Methods D 885. Describe the material or product sampled and the method of sampling used.

25.4.2 Report the option or procedure used, the number of specimens tested, and the elongation at break for the sample.

25.5 *Precision and Bias:*

25.5.1 *Precision*—See Section 39.

25.5.2 *Bias*—See 39.3.

26. Force at Specified Elongation (FASE) of Oven-Dried Rayon Yarns and Cords

26.1 *Scope*—This test method is used to determine the force at specified elongation (FASE) of oven-dried rayon yarns and cords.

26.2 Determine the FASE of each oven-dried rayon specimen when determining its breaking force (see 23.4). Read the force directly from the autographic recorder chart, or by electronic means, at the appropriate value of elongation for the product listed in Table 2.

26.3 *Calculation*—Calculate the average FASE of the sample to the nearest 0.5 N (0.05 gf/den).

26.4 *Report:*

26.4.1 State that the specimens were tested as directed in Section 26 of Test Methods D 885. Describe the material or product sampled and the method of sampling used.

26.4.2 Report the option or procedure used, the number of specimens tested, and the FASE for the sample.

26.5 *Precision and Bias:*

26.5.1 *Precision*—See Section 39.

26.5.2 *Bias*—See 39.3.

27. Work-to-Break of Yarns and Cords

27.1 *Scope*—This test method is used to determine the work-to-break of yarns and cords.

27.2 *Procedure*—Using the force-elongation curves obtained as directed in Section 16, 17, 23, or X2.3, draw a line from the point of the breaking force of each specimen perpendicular to the elongation axis. Measure the area bounded by the curve, the perpendicular, and the elongation axis. This area may be estimated by counting squares, measured with a planimeter, or determined by electronic means.

27.3 *Calculation:*

27.3.1 Calculate the work-to-break for each specimen using Eq 25 and Eq 26:

$$WB_j = A \times F_{sf} \times E_{sf\%} \times 10^{-5} \times L_o \quad (25)$$

$$WB_i = A \times F_{sf} \times E_{sf\%} \times 10^{-2} \times L_o \quad (26)$$

where:

WB_j = work-to-break, J,

WB_i = work-to-break, in.·lbf,

A = area under force-elongation curve, mm² (in.²),

F_{sf} = force scale factor, N/mm (lbf/in.) of chart,

$E_{sf\%}$ = elongation scale factor, %, of specimen elongation per mm (in.) of autographic chart, and

L_o = gage length of specimen, mm (in.).

27.3.2 Calculate specific work-to-break using Eq 27 and Eq 28:

$$WB_{sj} = A \times F_{sf} \times E_{sf\%} \times 10^{-2} \quad (27)$$

$$WB_{si} = A \times F_{sf} \times E_{sf\%} \times 10^{-2} \quad (28)$$

where:

WB_{sj} = specific work-to-break, J/m,

WB_{si} = specific work-to-break, in.·lbf/in.,

A = area under force-elongation curve, mm²(in.²),

F_{sf} = force scale factor, N/mm (lbf/in.) of chart, and

$E_{sf\%}$ = elongation scale factor, %, of specimen elongation per mm (in.) of autographic chart.

27.3.3 The equations used to calculate work-to-break and specific work-to-break electronically are given in Eq 29-32:

$$WB_j = [(F_o + F_a)/2] \times [(E_d/1000) + \text{sum} ((F_i + F_{i+1})/2 \times ((E_{i+1} - E_i)/1000))] \quad (29)$$

$$WB_i = [(F_o + F_a)/2] \times [(E_a + \text{sum} ((F_i + F_{i+1})/2 \times ((E_{i+1} - E_i)))] \quad (30)$$

$$WB_{sj} = (1000 \times WB_j)/L_o \quad (31)$$

$$WB_{si} = WB_i/L_o \quad (32)$$

where:

WB_j = work-to-break, J,

WB_i = work-to-break, in.·lbf,

F_o = force at pretension level, N (lbf),

F_a = force at first data pair, N (lbf),

F_i = force at *i*th data pair, N (lbf),

E_a = extension at first data pair, mm (in.),

E_i = extension at *i*th data pair, mm (in.),

WB_{sj} = specific work-to-break, J/m,

WB_{si} = specific work-to-break, in.·lbf/in., and

L_o = gage length of specimen, mm (in.).

27.4 *Report:*

27.4.1 State that the specimens were tested as directed in

Section 27 of Test Methods D 885. Describe the material or product sampled and the method of sampling used.

27.4.2 Report the option or procedure used, the number of specimens tested, and the work-to-break for the sample.

27.5 *Precision and Bias*:

27.5.1 *Precision*—See Section 39.

27.5.2 *Bias*—See 39.3.

28. Breaking Toughness of Yarns and Cords

28.1 *Scope*—This test method is used to determine the breaking toughness of yarns and cords.

28.2 *Procedure*—Use the information developed in Sections 11 and 27 to calculate the breaking toughness of a yarn or cord sample.

28.3 *Calculation*:

28.3.1 Calculate the breaking toughness of each specimen using Eq 33, Eq 34 or Eq 35 and Eq 36:

$$BT_j = (A \times F_{sf} \times E_{sf\%}) \times 10/(LD_t) \quad (33)$$

$$BT_i = (A \times F_{sf} \times E_{sf\%}) \times 10^{-2}/(LD_d) \quad (34)$$

$$BT_j = (WB_{sj} \times 10^3)/LD_t \quad (35)$$

$$BT_i = WB_{si}/LD_d \quad (36)$$

where:

- BT_j = breaking toughness, J/g,
- BT_i = breaking toughness, in.·lbf/in.·den,
- A = area under the force-elongation curve, mm² (in.²),
- F_s = force scale factor, N/mm (lbf/in.),
- $E_{sf\%}$ = elongation scale factor, % of specimen elongation per mm (in.) of autographic chart,
- LD_t = measured linear density of specimen, tex,
- LD_d = measured linear density of specimen, denier,
- WB_{sj} = specific work-to-break of specimen, J/m, and
- WB_{si} = specific work-to-break of specimen, in.·lbf/in.·den.

28.3.2 The equations used to calculate breaking toughness electronically are given in Eq 37 and Eq 38:

$$BT_j = (1000 \times WB_{sj})/(L_o \times LD_t) \quad (37)$$

$$BT_i = WB_{si}/(L_o \times LD_d) \quad (38)$$

where:

- BT_j = breaking toughness, J/g,
- BT_i = breaking toughness, in.·lbf/in.·den,
- WB_{sj} = specific work-to-break of specimen, J/m,
- WB_{si} = specific work-to-break of specimen, in.·lbf/in.·den,
- L_o = gage length of specimen, mm (in.),
- LD_t = measured linear density of specimen, tex, and
- LD_d = measured linear density of specimen, denier.

28.4 *Report*:

28.4.1 State that the specimens were tested as directed in Section 28 of Test Methods D 885. Describe the material or product sampled and the method of sampling used.

28.4.2 Report the option or procedure used, the number of specimens tested, and the breaking toughness for the sample.

28.5 *Precision and Bias*:

28.5.1 *Precision*—The precision of breaking toughness is derived from work-to-break and linear density (see Section 16).

28.5.2 *Bias*—See 39.3.

29. Reports, General

29.1 State that all specimens were tensile tested as directed in Test Methods D 885, Sections 12-28. Describe the material or product sampled and the methods of sampling used.

29.2 Report the following information:

29.2.1 Test procedure used (pretension or slack start),

29.2.2 Type of tensile testing machine used,

29.2.3 Type of clamp used,

29.2.4 The amount of twist, if any, inserted into the yarn especially for the purpose of tensile testing the yarn,

29.2.5 Number of specimens tested per sample, and

29.2.6 The value of each property measured or calculated for each sample.

OTHER YARN AND CORD PROPERTIES

30. Twist in Yarns and Cords

30.1 *Scope*—This test method is used to determine the amount of twist in yarns and cords.

30.2 *Number of Specimens*—Test ten specimens. This number is based on the assumption that the applicable coefficient of variation is 3.0 % and the allowable variation is 1.9 % at a probability level of 95 %.

30.3 *Procedure*—Determine the twist in single yarn, plied yarn, and tire cord as directed in Test Method D 1423, 9.2 through sections 9.5, except use a tension of 5 ± 1 mN/tex (0.05 ± 0.01 gf/den) based on the nominal yarn or cord linear density (see Note 6). When all but one of the elements of the untwisted cord have been cut prior to determining the twist of an individual element, leave the total force unchanged even though the tension per unit linear density in the element will be higher than in the original cord. Before determining the twist of the element, record its length after all but one of the elements have been cut away from the untwisted cord. Use this length when calculating the twist in the element using Eq 7 of Test Method D 1423.

NOTE 6—For convenience in routine testing, an approximation of the specified tension may be obtained by applying one of the forces listed as follows for the specified groups of yarn and cord sizes.

Linear Density of Specimen	Amount of Force	
	N	gf
Below 400 tex (3600 denier)	1	100
400 to 600 tex (3600 to 5400 denier)	2	200
600 to 800 tex (5400 to 7200 denier)	3	300
Above 800 tex (7200 denier)	4	400

30.4 *Calculation*—Calculate the twist of all specimens as directed in Sections 10.1 through 10.4 of Test Method D 1423.

30.5 *Report*:

30.5.1 State that the specimens were tested as directed in Section 30 of Test Methods D 885. Describe the material or product sampled and the method of sampling used.

30.5.2 Report the option or procedure used, the number of specimens tested, and twist of each specimen.

30.6 *Precision and Bias*:

30.6.1 *Precision*—See Section 39.

30.6.2 *Bias*—See 39.3.

31. Thickness of Cords

31.1 *Scope*—This test method is used to determine the thickness of cords.

31.2 *Summary of Test Method*—The average thickness (gage) of a group of parallel tire cords resting on an anvil is determined when under a specified pressure applied by the presser foot of a thickness gage.

31.3 *Apparatus*—The thickness gage shall conform with the requirements specified in Section 6.1 of Test Method D 1777. The gage shall be equipped with a presser foot having a diameter of 10 mm ($\frac{3}{8}$ in.) and shall exert a pressure of approximately 25 kPa (3.4 psi) (related to the presser foot area).

31.4 *Number of Specimens*—Test five specimens. This number is based on the assumption that the applicable coefficient of variation is 1.0 % and the allowable variation is 1.5 % of the average at a probability level of 95 %.

31.5 *Procedure*—Take a specimen comprised of four cords from the sample and handle the cords in such a manner that no change of twist can occur. For tabby samples of tire cord fabric, prior to removing each set of four cords, position the cords adjacent and parallel with no ends crossed. Grasp the four cords with the length of the cords between the fingertips of the left hand and the right hand approximately equal to the length of the anvil. Use care to avoid any change in twist if the hands are repositioned after the set of four cords are removed from the tabby sample. Inspect the top and bottom of the specimen to be sure that no knots, splices, or foreign protuberances are present on the lengths of cord to be gaged. Place the four cords side by side on the anvil and directly under the presser foot of the thickness gage. Apply sufficient tension to make the cords taut (about 5 N (1 lbf)) (see Note 7). Lower the presser foot gradually and gently (take about 5 s to apply the full force) by keeping a finger or thumb in contact with the lowering lever until the presser is in contact with the cord specimen. Wait until the gage reading becomes stable (about 5 s), and record the thickness of the specimen to the nearest 0.01 mm (0.0005 in.). Make only one measurement of each specimen of four cords.

NOTE 7—Laboratory tests have shown that the average tension applied by an operator to four parallel cords held between the fingertips was about 5 N (1 lbf). Tensions considerably greater than 5 N (1 lbf) usually result in cord slippage. Tests using a tension in the range from 2 to 7 N (0.5 to 1.5 lbf) resulted in no significant change in cord thickness, as measured.

31.6 *Calculation*—Calculate the average thickness of the specimens to the nearest 0.01 mm (0.0005 in.).

31.7 *Report*:

31.7.1 State that the specimens were tested as directed in Section 31 of Test Methods D 885. Describe the material or product sampled and the method of sampling used.

31.7.2 Report the option or procedure used, the gage used, the number of specimens tested, and the thickness for the sample.

31.8 *Precision and Bias*:

31.8.1 *Precision*—See Section 39.

31.8.2 *Bias*—See 39.3.

32. Extractable Matter in Yarns and Cords

32.1 *Procedure*:

32.1.1 Determine the amount of extractable matter present in yarns and cords as directed in Test Method D 2257.

32.2 *Report*:

32.2.1 State that the specimens were tested as directed in

Test Method D 2257. Describe the material or product sampled and the method of sampling used.

32.2.2 Report the option used and the number of specimens tested.

33. Dip (Adhesive) Solids Pickup on Yarns and Cords

33.1 *Scope*—This test method is used to determine the amount of dip solids pickup on yarns and cords.

33.2 *Summary of Test Method*—Individual procedures are given for determining the amount of adhesive dip solids for specimens nylon, polyester, and rayon yarns or cords that have been treated with resorcinol-formaldehyde-latex (RFL) type of adhesive dip by dissolving the fiber in an appropriate solvent and recovering the residue of dip solids by filtration after which it is dried and weighed. The amount of adhesive solids on a specimen is reported as percentage dip solids pickup based on the oven-dried mass of the dip-free specimen.

33.3 *Significance and Use*:

33.3.1 Textile yarns and cords are treated with an adhesive dip to improve the adhesion of elastomers to the textile materials. The amount of dip solids pickup on the yarns or cords is used for process control.

33.3.2 This test method for testing dip pickup is not recommended for acceptance testing of commercial shipments of dipped yarns or cords because of large between-laboratory variations.

33.4 *Apparatus and Materials*:

33.4.1 *Oven, convection*, controlled at $105 \pm 3^\circ\text{C}$ ($221 \pm 6^\circ\text{F}$).

33.4.2 *Extraction Flasks*, capacity 250 mL, borosilicate glass, with interchangeable ground-glass joints.

33.4.3 *Glass-Fiber Filter Disks*.

33.4.4 *Glass Weighing Bottles*, with ground-glass stoppers, 40 mm (1.5 in.) in diameter and 80 mm (3 in.) in height.

33.4.5 *Gooch Crucible*, No. 4.

33.4.6 *Vacuum Flask*, 1-L capacity.

33.4.7 *Water-Cooled Condensers*, borosilicate glass, with interchangeable ground-glass joints.

33.4.8 *Water Bath*.

33.4.9 *Desiccator*, with silica gel.

33.5 *Reagents*:

33.5.1 *For Nylon Yarns and Cords*:

33.5.1.1 *Formic Acid* (HCOOH), 90 %.

33.5.2 *For Polyester Yarns and Cords*:

33.5.2.1 *Methylene Chloride* (CH₂Cl₂), reagent grade.

33.5.2.2 *Trichloroacetic Acid* (Cl₃CCOOH), reagent grade.

33.5.2.3 *Trichloroacetic Acid, Methylene Chloride Solution* (30 % (w/v))—Dissolve 300 g of trichloroacetic acid crystals in 1000 mL of methylene chloride.

33.5.3 *For Rayon Yarns and Cords*:

33.5.3.1 *Sulfuric Acid* (H₂SO₄), concentrated, density 1.84 g/cm³, reagent grade.

33.5.3.2 *Sulfuric Acid* (H₂SO₄), approximately 71 %—Pour slowly, with constant stirring, 420 mL of concentrated sulfuric acid into 260 mL of distilled water.

33.6 *Hazards*:

33.6.1 Use extreme care, wear rubber gloves and goggles, and work in a hood with forced ventilation when handling acids and methylene chloride.

33.6.2 Refer to manufacturers' Material Safety Data Sheet (MSDS) for information on handling, use, storage, and disposal of all chemicals used in this test method.

33.7 Procedure:

33.7.1 For Nylon Yarns and Cords:

33.7.1.1 Cut approximately 3 g of dipped nylon yarn or cord into pieces no longer than 10 mm (1/4 in.) and place the pieces in a weighing bottle. Dry this specimen in the oven at a temperature of 105 ± 3°C (221 ± 6°F) to a constant mass.

33.7.1.2 Remove the specimen from the oven, close the weighing bottle, and cool in a desiccator.

33.7.1.3 Weigh the bottle plus the specimen to the nearest 1 mg and determine the mass of the specimen by difference. Transfer the specimen to a 500-mL beaker and add about 250 mL of 90 % formic acid. Dissolve the nylon at room temperature with occasional stirring of the solution.

33.7.1.4 Filter the solution through a tared crucible that contains a glass-fiber filter disk. Wash the beaker and residue with two 25-mL portions of formic acid and allow the acid to filter slowly through the residue each time. Wash the residue with four 25-mL portions of water in the same manner as above.

33.7.1.5 Dry the residue and crucible at a temperature of 105 ± 3°C (221 ± 6°F) to a constant mass. Cool in a desiccator and weigh to the nearest 1 mg.

33.7.2 For Polyester Yarns and Cords:

33.7.2.1 Cut approximately 2 g of dipped polyester yarn or cord into pieces no longer than 10 mm (1/4 in.) and place the pieces in a weighing bottle. Dry this specimen in the oven at a temperature of 105 ± 3°C (221 ± 6°F) to a constant mass.

33.7.2.2 Remove the specimen from the oven, close the weighing bottle, and cool in a desiccator.

33.7.2.3 Weigh the bottle plus specimen to the nearest 1 mg and determine the mass of the specimen by difference. Transfer the specimen to the 250-mL extraction flask and add about 75 mL of the trichloroacetic acid-methylene chloride solution. Attach the flask to the condenser and reflux for 15 min or until the polyester is dissolved.

33.7.2.4 Filter the solution through a tared crucible that contains a glass-fiber filter disk. Wash the flask and residue on the filter disk with three successive 25-mL portions of methylene chloride.

33.7.2.5 Dry the crucible and filter disk with the dip solids residue at a temperature of 105 ± 3°C (221 ± 6°F) to constant mass. Cool in a desiccator and weigh to the nearest 1 mg.

33.7.3 For Rayon Yarns and Cords:

33.7.3.1 Cut approximately 3 g of dipped rayon yarn or cord into pieces no longer than 6 mm (1/4 in.) and place in a weighing bottle. Dry this specimen in the oven at a temperature of 105 ± 3°C (221 ± 6°F) to a constant mass.

33.7.3.2 Remove the specimen from the oven, close the weighing bottle, and cool in a desiccator.

33.7.3.3 Weigh the bottle plus specimen to the nearest 1 mg and determine the mass of the specimen by difference. Transfer the specimen to a 250-mL beaker and add about 150 mL of the H₂SO₄, which has been heated to a temperature of 30 ± 5°C (86 ± 9°F), to the specimen in the beaker with stirring of the solution. Maintain the mixture at the above temperature and

stir continuously until the fibers appear to be completely dissolved, then stir for an additional 20 min.

33.7.3.4 Filter the solution through a tared crucible which contains a glass-fiber filter disk. Wash the beaker and residue with successive 25-mL portions of water until the wash water is acid-free when tested with methyl red.

33.7.3.5 Dry the residue and crucible at a temperature of 105 ± 3°C (221 ± 6°F) to constant mass, cool in a desiccator, and weigh the residue.

33.8 Calculation:

33.8.1 Calculate the amount of dip pickup for each specimen using Eq 39.

$$DPU = [M_{or}/(M_o - M_{or})] \times 100 \quad (39)$$

where:

DPU = percentage dip pickup, %,

M_{or} = mass of oven-dried residue, g, and

M_o = mass of oven-dried specimen, g.

33.8.2 Calculate the average dip pickup for the specimen to the nearest 0.1 %.

33.9 Report:

33.9.1 State that the specimens were tested as directed in Section 33 of Test Methods D 885. Describe the material or product sampled and the method of sampling used.

33.9.2 Report the option or procedure used, the number of specimens tested, and the dip pickup for the sample.

33.10 Precision:

33.10.1 For Nylon Yarns and Cords:

33.10.1.1 Interlaboratory Test Data—An interlaboratory test was run in 1968 in which three laboratories each tested dipped cord specimens from a single sample. A single nylon cord at a dip pickup level of approximately 5 % was wound on a drum, cut off the drum, and the resulting 250 to 300-mm (10 to 12-in.) lengths of cord were thoroughly mixed. Each participating laboratory was supplied a bundle of these short cords taken at random from the sample described. Each laboratory made five determinations on two different occasions. The components of variance for dip pickup results expressed as coefficients of variation were calculated to be as follows:

Within-laboratory component	2.13 % of the average
Between-laboratory component	6.14 % of the average

33.10.1.2 Precision—For the components of variance reported in 33.10.1, two averages of observed values should be considered significantly different at the 95 % probability level if the difference equals or exceeds the critical differences listed in Table 5.

TABLE 5 Dip Pickup Critical Difference, % of Grand Average, for the Conditions Noted^{A,B}

Number of Observations in Each Average	Single-Operator Precision	Between-Laboratory Precision
1	5.90	18.01
5	2.64	17.22
10	1.87	17.12

^AThe critical differences were calculated using $t = 1.960$, which is based on the infinite number of degrees of freedom.

^BTo convert the values of the critical differences to units of measure, multiply the average of the two specific sets of data being compared by the critical differences expressed as a decimal fraction.

33.10.1.2.1 The within-laboratory component of variance is the sum of all the individual components of variance, except the single-operator component of variance, that contribute to the variability of observations within a single laboratory. Included are such components of variance as those for days of testing, units of apparatus, and different operators within a single laboratory. If the within-laboratory component of variance is not calculated separately, all sources of variability except the single-operator component are included in the between-laboratory component. Under these conditions, calculate the standard error (between-laboratory) using zero for the within-laboratory component.

33.10.2 For Polyester Yarns and Cords:

33.10.2.1 *Interlaboratory Test Data*—Data on components of variance are not available.

33.10.2.2 *Within-Laboratory Precision*—The uncertainty (0.95 level) of single measurements made in one laboratory has been found to be $\pm 10\%$ of the average dip solids pickup.

33.10.2.3 *Between-Laboratory Precision*—The uncertainty (0.95 level) in the difference between two laboratories, each making five measurements, has been found to be $\pm 15\%$ of the average dip solids pickup.

33.10.3 For Rayon Yarns and Cords:

33.10.3.1 *Interlaboratory Test Data*—The values of precision are based on interlaboratory testing by eight laboratories of a standard sample that contained about 5% adhesive dip solids pickup. Components of variance are not available.

33.10.3.2 *Within-Laboratory Precision*—The uncertainty (0.95 level) of single measurements made in one laboratory has been found to be $\pm 10\%$ of the average dip solids pickup.

33.10.3.3 *Between-Laboratory Precision*—The uncertainty (0.95 level) in the difference between two laboratories, each making five measurements, has been found to be $\pm 15\%$ of the average dip solids pickup.

34. Adhesion of Cord to Elastomers

34.1 Determine the adhesion of tire cords to elastomers using either Test Method D 4393 or D 4776 (see Note 8).

NOTE 8—Other tire cord adhesion tests currently are being studied by ASTM Committee D-11 on Rubber and Rubber-Like Products and Committee D-13.

PROPERTIES OF TIRE CORD FABRIC

35. Width

35.1 Determine the width of tire cord fabric as directed in Test Method D 3774.

36. Mass per Unit Area

36.1 Determine the mass per unit area of tire cord fabric as directed in Test Method D 3776 (Option A or B as appropriate).

37. Count

37.1 Determine the count of tire cord fabric as directed in Test Method D 3775 except count the filling yarns in a specimen of fabric having a length of at least 250 mm (10 in.).

38. Stiffness of Fabric

38.1 *Scope*—This test method is used to determine the stiffness of tire fabric specimens.

38.2 *Summary of Test Method*—Specimens of tire fabric are analyzed for stiffness using a CRE-type tensile testing machine, having normal jaws replaced with a holder or rack that allows the sample to rest across a 25-mm (1-in.) span opening. The specimen is deflected by a depressor applied in the center of the span and the force in millinewtons (grams-force) required to depress the specimen is recorded and averaged.

38.3 *Significance and Use*—Stiffness of treated fabric is a factor influencing the handling, fabrication, and performance of the finished product. Specified stiffness values are inappropriate because of the variety of applications of tire cord fabrics, the equipment for fabricating articles from such fabric, and post-treatment that may occur prior to the use of the fabric; all of the foregoing may bear on the degree of stiffness needed or that can be tolerated.

38.4 Apparatus:

38.4.1 *CRE-Type Tensile Testing Machine.*

38.4.2 *Loading Cell, 20 N (2000 gf).*

38.4.3 *Specimen Holder*—An 85-mm ($3\frac{3}{8}$ -in.) square frame made of 5-mm ($\frac{1}{4}$ -in.) diameter steel rod. In the middle of one side is a hook made of 3-mm ($\frac{1}{8}$ -in.) rod diameter for connecting the holder to the loading cell. In the middle of the opposite side, there is a 22-mm ($\frac{7}{8}$ -in.) long, 5-mm ($\frac{1}{4}$ -in.) diameter rod fastened at midpoint and at right angles to the side of the frame. These two “T’s,” 25-mm (1-in.) apart, form a rack on which the test specimens lay across the 25-mm (1-in.) opening (see Fig. 4).

38.4.3.1 For CRE-type tensile testing machines, which are able to measure under compression, a 3-point bending fixture with a distance between the lower rollers of 25-mm (1-in.) can be used in place of the above described specimen holder. The lower rollers have a radius of 5-mm ($\frac{1}{4}$ -in.) and the upper roller has a radius of 6-mm ($\frac{1}{4}$ -in.) (see Fig. 5).

38.4.4 *Specimen Depressor, 85-mm ($3\frac{3}{8}$ -in.) square frame, made of 5-mm ($\frac{1}{4}$ -in.) diameter steel rod, rigidly fastened with a threaded connector to the lower crosshead. The side opposite the crosshead connection is covered with a 6-mm ($\frac{1}{4}$ -in.) diameter piece of steel tubing. This forms a bar, which presses against specimens to bend them during the test (see Fig. 4).*

38.5 Number of Specimens:

38.5.1 Test the number of specimens such that the user may expect at the 95% probability level that the test result is no more than 3.50% of the average above or below the true average (that is, a theoretical average obtained from an infinite number of observations). Determine the number of specimens in accordance with Practice D 2258.

38.6 Specimen Preparations:

38.6.1 Cut each 50-mm (2-in.) specimen of fabric to contain 16 ends. Select specimens that are as straight as possible. Do not preflex specimens before testing. Remove three ends from each edge of each specimen, leaving ten warp ends and all the filling in the sample.

38.7 Procedure:

38.7.1 Mount the specimen holder and depressor in the testing machine, calibrate, and set the tester at zero.

38.7.2 Adjust the crosshead with the presser bar of the depressor approximately 6-mm ($\frac{1}{4}$ -in.) above the opening in the specimen rack.

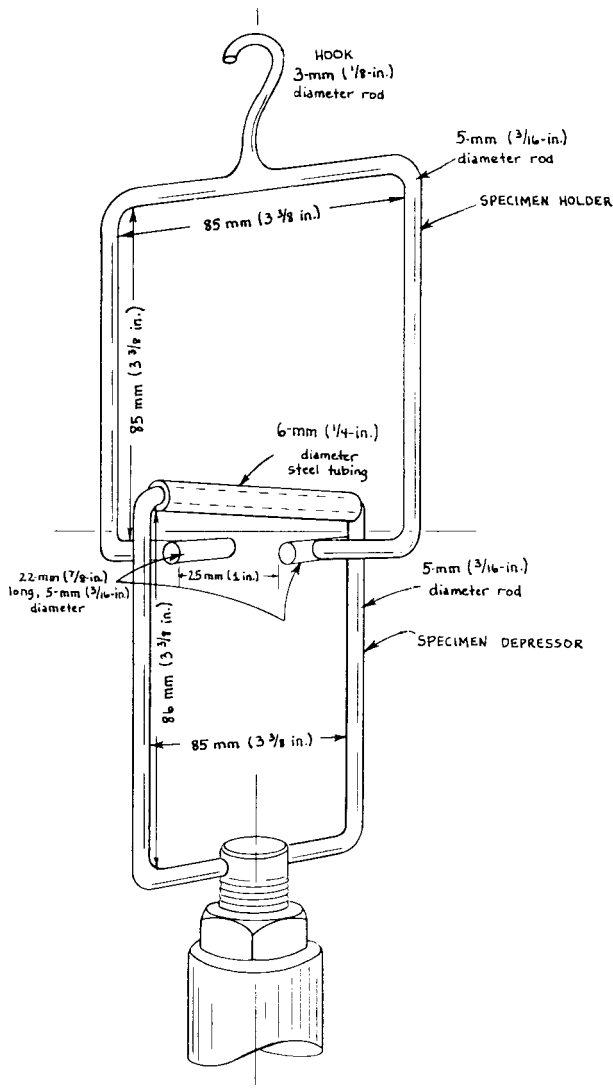

FIG. 4 Apparatus for Stiffness of Fabric Testing

38.7.3 Set the crosshead speed at 25-mm/min (1-in./min) and the chart speed at 125-mm/min (5-in./min). Set the load selector for the minimum scale force to accommodate the specimen and for the bending force to occur between 10 and 90 % of full-scale force, preferably at mid-scale.

38.7.4 Place the specimen on the rack with the middle of the specimen at the midpoint of the rack and the longitudinal axis of the specimen parallel to the 25-mm (1-in.) opening.

38.7.5 Start the tester to lower the crosshead and pull the presser bar onto the specimen and through the opening in the specimen rack.

38.7.6 Record the maximum force required to pull the specimen through the opening to the nearest 1 mN (0.1 gf).

38.8 Calculation:

38.8.1 Calculate the average stiffness results for the sample to the nearest 1 mN (0.1 gf).

38.9 Report:

38.9.1 State that the specimens were tested as directed in Section 38 of Test Methods D 885. Describe the material or product sampled and the method of sampling used.

38.9.2 Report the option or procedure used, the number of specimens tested, and the fabric stiffness for the sample.

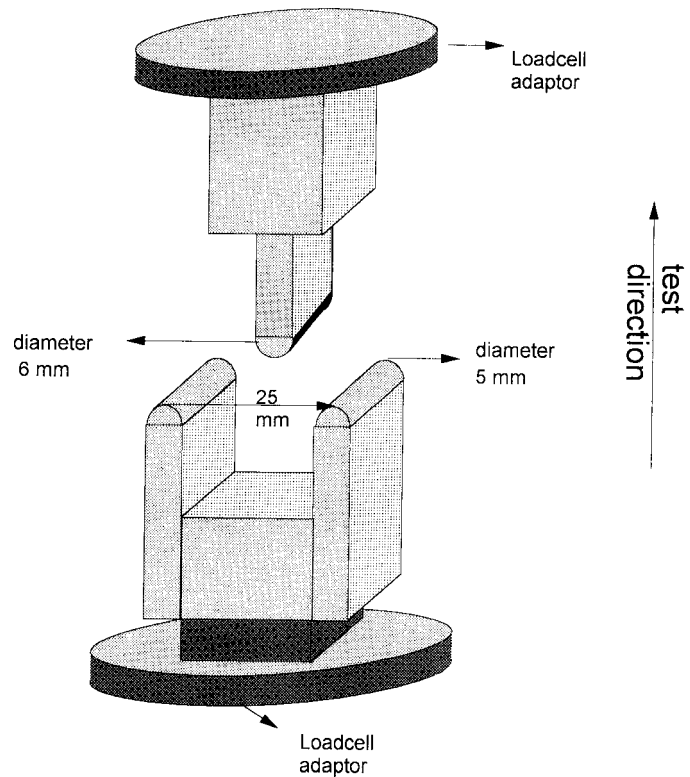

FIG. 5 Alternative Apparatus for Stiffness of Fabric Testing

38.10 Precision and Bias:

38.10.1 Interlaboratory Test Data⁷—An interlaboratory test was run in 1974 in which randomly drawn samples of one material were tested in each of five laboratories using the apparatus in Fig. 4. The operator in each laboratory tested five specimens of each material. The components of variance of stiffness property results expressed as coefficients of variation were calculated to be as follows:

Single-operator component	2.65 % of the average
Between-laboratory component	3.36 % of the average

38.10.2 Precision—For the components of variance reported in 38.10.1, two averages of observed values should be considered significantly different at the 95 % probability level if the difference equals or exceeds the critical differences listed in Table 6.

⁷ ASTM Research Report No. RR:D13-1040. A copy is available from ASTM Headquarters, 100 Barr Harbor Drive, W. Conshohocken, PA 19428.

TABLE 6 Critical Difference, % of Grand Average, for the Conditions Noted^{A,B}

Number of Observations in Each Average	Single-Operator Precision	Between-Laboratory Precision
1	7.34	11.90
5	3.28	9.87
10	2.32	9.60

^AThe critical differences were calculated using $t = 1.960$, which is based on the infinite number of degrees of freedom.

^BTo convert the values of the critical differences to units of measure, multiply the average of the two specific sets of data being compared by the critical differences expressed as a decimal fraction.

38.10.2.1 The tabulated values of the critical differences should be considered to be a general statement, particularly with respect to between-laboratory precision. Before a meaningful statement can be made about two specific laboratories, the amount of statistical bias, if any, between them must be established, with each comparison being based on recent data obtained on randomized specimens from one sample of the material to be tested.

38.10.3 *Bias*—No justifiable statement on the bias of Test Methods D 885 for measuring the stiffness of fabric can be made since the value of the property cannot be established by an accepted referee method.

SPECIFIC PRECISION AND BIAS AND KEYWORDS

39. Precision and Bias of Certain Cord Tests

39.1 *Interlaboratory Test Data*—An interlaboratory test was run in 1969 in which replicate samples from three tire cord materials were sent to eight laboratories. The samples were tested on two different occasions in each laboratory. These materials were greige 93 tex Z 470 tpm/2 S 470 tpm, 186 tex (840/2 denier) nylon; 111 tex Z 390 tpm/3 S 390 tpm, 333 tex (1000/3 denier) polyester; and 183 tex Z 430 tpm/3 S 390 tpm, 549 tex (1650/3 denier) rayon. Each laboratory received a small spool from a single lot of each material. Cord spools of all three materials were prepared in a single laboratory and sent to each laboratory participating in the interlaboratory test. Similar specimen preparation and interlaboratory tests were completed on 167 tex/1 (1500/1 denier) aramid yarn in 1973 and on two constructions of 167 tex Z 300/2 S 300 tpm, 334 tex (1500/2 denier) aramid cords in 1974. In each interlaboratory test, a variety of properties were determined on each specimen. The FASE results were initially withheld from Table 2 and

Table 7 because of excessive variation, and a separate aramid FASE interlaboratory test program was completed in 1983 on greige and treated 167/2 tex (1500/1/2 denier) cord with and without the use of rosin to reduce clamp slippage. Rosin use altered results without reducing variation, providing higher FASE values when the entire sample was treated, and intermediately high values when only clamp areas were treated. The FASE values shown are for non-rosin treated specimens. In 1974, a separate interlaboratory test was run on linear density in which other replicate samples in two forms, bobbin and tabby, from three tire cord materials were sent to nine laboratories. Five linear density determinations were made on three occasions in each laboratory. The components of variance expressed as coefficients of variation were calculated and are listed in Table 2. Facilities for measurement of a given property varied among laboratories; therefore, the listing in Table 2 does not always show the same number of participating laboratories for each property measurement.

39.2 *Precision*—For the components of variance reported in Table 6, two averages of observed values should be considered significantly different at the 95 % probability level if the difference equals or exceeds the critical differences shown in Table 7.

39.3 *Bias*—No justifiable statement on the bias of the procedures in Test Methods D 885 for measuring various properties of tire cords can be made because the value of the properties cannot be established by referee methods.

40. Keywords

40.1 commercial mass; dip pickup; industrial yarn; linear density; manufactured fibers; moisture regain; shrinkage; tensile properties/tests; tire cord; tire fabric; twist

TABLE 7 Components of Variance Expressed as Coefficients of Variation (Except as Noted)

NOTE 1—Note—Between-laboratory coefficients of variation of high-modulus aramids are undesirably high and may warrant interlaboratory correlations in specific applications between the purchaser and the seller.

Property Measured	Number of Laboratories	Number of Observations in Each Laboratory	Degrees of Freedom		Coefficient of Variations	
			Within Laboratory	Between Laboratory	Within-Laboratory Component	Between-Laboratory Component
<i>Table 3a 840/2 Nylon Cord (12 × 12 twist):^A</i>						
Breaking strength, lbf	8	10	152	7	1.61	1.57
Elongation at break, %	6	10	114	7	5.13	4.63
Load at specified elongation (LASE) (reported at 14 % E), lbf	7	10	133	6	5.67	7.25
Modulus, gf/den	2	10	38	1	5.76	2.38
Work-to-break, in.-lbf/in.	4	10	76	2	7.63	2.88
Thickness of cords, mils	4	10	76	3	0.64 ^B	0.49 ^B
Twist, tpi: Cord	5	10	114	5	0.31 ^B	0.12 ^B
Singles	5	10	95	4	0.14 ^B	0.07 ^B
Linear density, den: ^A						
From bobbin	8	9 to 15	105	7	1.92	1.24
From tabby	8	9 to 15	71	7	0.73	1.49
<i>Table 3b 1000/3 Polyester Cord (10 × 10 twist):</i>						
Breaking Strength, lbf	5	10	95	4	1.96	1.56
Elongation at break, %	6	10	114	5	3.03	3.46
Load at specified elongation (LASE) (reported at 10 % E), lbf	6	10	114	5	5.88	5.31
Modulus, gf/den	2	10	38	1	5.42	0.00 ^C
Work-to-break, lbf/in.	4	10	76	3	5.51	5.53
Thickness of cords, mils	3	10	57	2	0.59 ^B	0.16 ^{B,C}
Twist, tpi: Cord	6	10	54	5	0.23 ^B	0.15 ^B
Singles	5	10	95	4	0.13 ^B	0.10 ^B
Linear Density, den:						
From bobbin	8	9 to 15	107	7	0.86	0.50
From tabby	8	9 to 15	79	7	1.17	0.79
<i>Table 3c 1650/3 Rayon Cord (11 × 10 twist):^D</i>						
Breaking strength, lbf	6	10	114	5	3.12	1.77
Elongation at break, %	6	10	114	5	3.47	2.07
Load at specified elongation (LASE) (reported at 6 % E), lbf	5	10	95	4	5.33	6.72
Thickness of cords, mils	3	10	57	2	0.75 ^B	0.71 ^B
Twist, tpi: Cord	4	10	76	3	0.28 ^B	0.16 ^B
Singles	3	10	57	2	0.16 ^B	0.09 ^B
Linear density, den:						
From bobbin	9	9 to 15	114	8	0.66	0.94
From tabby	9	9 to 15	94	8	0.73	0.78
<i>Table 3d 1500/2 High-Modulus Aramid Cord (4 × 4 twist):</i>						
Breaking strength, lbf	8	10	72	7	1.21	2.38
Elongation at break, %	8	10	72	7	2.58	7.46
Modulus, gf/den	5	10	45	4	3.67	7.01
Work-to-break, in.-lbf/in.	6	10	54	5	4.44	17.62
Thickness of cords, mils	6	10	54	5	0.88 ^B	3.86 ^B
Twist, tpi: Cord	7	10	63	6	0.10 ^B	0.12 ^B
Singles	7	10	63	6	0.10 ^B	0.08 ^B
<i>Table 3e 1500/2 High-Modulus Aramid Cord (7.5 × 7.5 twist):</i>						
Breaking strength, lbf	8	10	72	7	2.41	3.45
Elongation at break, %	8	10	72	7	2.49	9.60
Modulus, gf/den	5	10	45	4	2.43	12.76
Work-to-break, in.-lbf/in.	6	10	54	5	9.60	15.50
Thickness of cords, mils	6	10	54	5	0.88 ^B	3.05 ^B
Twist, tpi: Cord	7	10	63	6	0.10 ^B	0.20 ^B
Singles	7	10	63	6	0.10 ^B	0.20 ^B
Load at specified elongation (LASE) without Rosin (reported at 2 % E), lbf	9	10	81	8	1.59	5.79
<i>Table 3f 1500/1 High-Modules Aramid Yarn:</i>						
Breaking strength, lbf	6	10	9	5	1.52	3.38
Elongation at break, %	5	10	9	4	2.91	8.39
Modulus, gf/den	3	10	9	2	5.06	5.05

^A1260/2 nylon cord for linear density.

^BProperties that have components of variance as standard deviations in the units shown are noted in the table.

^CThe F-ratio indicates not significant at 95 % probability level.

^DRayon data, except thickness, twist, and linear density, are from oven-dry cords.

APPENDIXES

(Nonmandatory Information)

X1. GROWTH OF CONDITIONED YARNS AND CORDS

X1.1 *Scope*—This test method is used to determine growth of a specimen after conditioning in the atmosphere for testing industrial yarns and tire cords.

X1.2 *Summary of Test Method*—Initial length of a specimen of yarn or cord that has been permitted to relax in a conditioned atmosphere is determined while under a specified pretension force. A force is then applied to the specimen and its length again measured after the length of the loaded specimen becomes constant. The amount of growth is calculated from the differences in observed specimen lengths.

X1.3 *Significance and Use*—The growth of a yarn or cord is a factor in the dimensional stability under loading of a product that is reinforced with a specific textile material.

X1.4 *Apparatus*—A length measuring device upon which test specimens at least 250-mm (10-in.) long can be mounted with one end of each specimen in a fixed position. The apparatus shall be equipped with a means for measuring the initial length and the final length of each specimen during the test period. This device shall be designed so that a tension force can be attached to the free end of each specimen in such a manner that there shall be no change in twist.

X1.5 *Preparation of Specimens*—Test five specimens. Wind a skein sample of yarn or cord from a package or remove a tabby sample of tire cord fabric from the board to which it may be attached. Permit the sample to relax without kinking in the test atmosphere for a minimum of 48 h prior to testing.

X1.6 *Procedure*—Secure one end of a specimen at least 250-mm (10-in.) long in the clamp of the apparatus, and apply a pretension force of 5 ± 1 mN/tex (0.05 ± 0.01 gf/den) to the other end of the specimen in such a manner that there is no change in twist. Observe and record the initial length of the specimen. Apply an additional force to the specimen so that the total force is 100 ± 1 mN/tex (1.0 ± 0.01 gf/den). When the increase in amount of growth is no more than 5 % (based on change in length of a specimen) during a 1-min interval, observe and record the final length of the specimen.

X1.7 *Calculation:*

X1.7.1 Calculate the growth of each specimen to the nearest 0.1 % using Eq X1.1:

$$G = [(L_f - L_o)/L_o] \times 100 \quad (\text{X1.1})$$

where:

G = growth, %,

L_o = initial length of specimen, mm (in.), and

L_f = final length of specimen, mm (in.).

X1.7.2 Calculate the average growth of all specimens to the nearest 0.1 %.

X1.8 *Report:*

X1.8.1 State that the specimens were tested as directed in Appendix X1 of Test Methods D 885. Describe the material or product sampled and the method of sampling used.

X1.8.2 Report the option or procedure used, the number of specimens tested, and the growth for the sample.

X2. PROPERTIES OF YARNS AND CORDS AT ELEVATED TEMPERATURE

X2.1 *Scope*—This test method is used to determine the breaking strength (force), the shrinkage, and the shrinkage force of yarns and cords at elevated temperatures.

X2.2 *Significance and Use*—Because textile materials are often subjected to elevated temperatures during their processing and use, it is necessary to know the tensile properties and behavior at such temperatures. Such information is used in engineering calculations and in process specifications.

X2.3 *Breaking Strength (Force) of Yarns and Cords at Elevated Temperature:*

X2.3.1 *Summary of Test Method*—The breaking force of yarn or cord is determined while the specimen is at an elevated temperature. Elongation usually is not determined. This test is not a heat-aging test.

X2.3.2 *Apparatus*—A tensile testing machine as specified in Section 15, except that the machine shall be equipped with an oven or elevated temperature chamber that completely encloses

the testing clamps and specimen (see Note X2.1). The oven shall be such that it will maintain the required temperature.

NOTE X2.1—Air-actuated testing machine clamps as usually supplied are not suitable for use in ovens at high temperature without modification. Such modification consists of increasing the diameter of the cylinder to compensate for thermal effects and the use of rings of heat-resistant material on the pistons.

X2.3.3 *Procedure*—Test five specimens. Place a conditioned specimen of yarn or cord (for rayon, an oven-dried specimen prepared as directed in 23.3) in the clamps of the testing machine, enclose it in the oven and expose it to the specified temperature (see Note X2.3). When the specimen reaches the temperature of the oven, immediately determine its breaking force as directed in Section 16 (see Note X2.2).

NOTE X2.2—It is inappropriate on most materials to reliably measure strain-related properties, such as modulus, elongation at break, and FASE, at elevated temperatures.

NOTE X2.3—The temperature of the oven shall be $177 \pm 2^\circ\text{C}$ ($350 \pm 3^\circ\text{F}$).

X2.3.4 *Calculation*—Calculate the breaking strength for the sample, to the nearest 0.5 N (0.1 lbf), as the average of the observed breaking forces of the specimens at the specified temperature.

X2.3.5 *Report:*

X2.3.5.1 State that the specimens were tested as directed in X2.3 of Test Methods D 885. Describe the material or product sampled and the method of sampling used.

X2.3.5.2 Report the option or procedure used, the number of specimens tested, and the breaking strength for the sample.

X2.4 *Shrinkage of Conditioned Yarns and Cords at Elevated Temperature:*

X2.4.1 *Summary of Test Method*—The initial length of a specimen of yarn or cord that has been permitted to relax in a conditioned atmosphere is determined while under a specified force. After exposure of the loaded specimen to a specified temperature until its length becomes constant, the final length is measured and the amount of shrinkage is calculated from the difference in observed specimen lengths.

X2.4.2 *Apparatus*—A length-measuring device designed so that it can be exposed to an elevated temperature and upon which test specimens at least 250-mm (10-in.) long can be mounted with one end of each specimen in a fixed position. The device shall be equipped with a means for measuring the initial length and the final length of each specimen during the test period. This device shall be such that a tension weight can be attached to the free end of each specimen in such a manner that there shall be no change in twist.

X2.4.3 *Preparation of Specimens*—Test five specimens. Wind a skein sample of yarn or cord from a package or remove a tabby sample of tire cord fabric from the board to which it may be attached. Permit the sample to condition while relaxed without kinking in the test atmosphere for a minimum of 16 h prior to testing.

X2.4.4 *Procedure*—Secure one end of the specimen in the apparatus, and apply a tension of 5 ± 1 mN/tex (0.05 ± 0.01 gf/den) to the other end of the specimen in such a manner that there is no change in twist. Record the initial length of the specimen to the nearest 0.5 mm (0.02 in.). Place the apparatus with the specimen and weight in an oven at $177 \pm 2^\circ\text{C}$ ($350 \pm 3^\circ\text{F}$) (see Note X2.3). Expose the specimen until the rate of shrinkage of the specimen is less than 5 % of the shrinkage/min. Record the final length of the loaded specimen to the nearest 0.5 mm (0.02 in.) before removing it from the oven.

X2.4.5 *Calculation:*

X2.4.5.1 Calculate the shrinkage at the specified temperature of each specimen to the nearest 0.1 % using Eq X2.1:

$$S = [(L_o - L_f)/L_o] \times 100 \quad (\text{X2.1})$$

where:

S = shrinkage, %,

L_o = initial length of specimen, mm (in.), and

L_f = final length of specimen, mm (in.).

X2.4.5.2 Calculate the shrinkage for the sample as the average shrinkage of the specimens at the specified temperature.

X2.4.6 *Report:*

X2.4.6.1 State that the specimens were tested as directed in X2.4 of Test Methods D 885. Describe the material or product sampled and the method of sampling used.

X2.4.6.2 Report the option or procedure used, the number of specimens tested, and the shrinkage for the sample.

X2.5 *Shrinkage Force of Conditioned Yarns and Cords at Elevated Temperature:*

X2.5.1 *Summary of Test Method*—A specimen of yarn or cord is permitted to relax in a conditioned atmosphere. The conditioned specimen is mounted between fixed clamps under a specified pretension force and then exposed to a specified temperature. The maximum force developed during exposure is the shrinkage force of the specimen at the specified temperature (see X2.5.4.1).

X2.5.2 *Apparatus*—A force-measuring device in which a test specimen can be secured with its ends in fixed clamps a minimum distance of 250-mm (10-in.) apart, and that can be exposed to an elevated temperature. The clamp at one end of the device shall be attached to a strain gage connected with a recorder that covers the range to be tested or a mechanical device that measures changes in force without a significant change in the length of the specimen. The strain gage or mechanical device shall permit less than 25- μm change in specimen length when used under the maximum tension developed. The device shall permit the attachment of a pretension force to the end of the specimen opposite the strain gage, without any change in twist, prior to tightening the clamp.

X2.5.3 *Preparation of Specimens*—Test five specimens. Wind a skein sample of yarn or cord from a package or remove a tabby sample of tire cord fabric from the board to which it may be attached. Permit the sample to condition while relaxed without kinking in the test atmosphere for a minimum of 16 h prior to testing.

X2.5.4 *Procedure*—Secure one end of the specimen in the clamp attached to the strain gage or mechanical force-measuring device and apply a pretension of 5 ± 1 mN/tex (0.05 ± 0.01 gf/den) to the other end of the specimen using care to avoid any change in twist. Secure the other end of the specimen in the other clamp while it is under the pretension. Remove the pretension and place the apparatus with the specimen in the oven at $177 \pm 2^\circ\text{C}$ ($350 \pm 3^\circ\text{F}$) (see Note X2.3). Expose the specimen until the rate of increase in force exerted by the specimen is less than 5 %/min. Record to the nearest 10 mN (0.002 lbf) the maximum force developed by the specimen while it is in the oven.

X2.5.4.1 If a strain gage with recorder is used, a complete force-time curve may be obtained.

X2.5.5 *Calculation:*

X2.5.5.1 Calculate the tenacity for each specimen using Eq X2.2:

$$ST = F_m/LD \quad (\text{X2.2})$$

where:

ST = shrinkage tenacity, mN/tex (gf/den),

F_m = maximum force developed by the specimen, mN (gf), and
 LD = linear density of the specimen, tex (denier).

X2.5.5.2 Calculate the shrinkage tenacity for the sample, to the nearest 0.1 mn/tex (0.001 gf/den), as the average shrinkage tenacity of the specimens at the specified temperature.

X2.5.6 Report:

X2.5.6.1 State that the specimens were tested as directed in X2.5 of Test Methods D 885. Describe the material or product sampled and the method of sampling used.

X2.5.6.2 Report the option or procedure used, the number of specimens tested, and the shrinkage tenacity for the sample.

X3. CONTRACTION OF WET YARNS AND CORDS

X3.1 *Scope*—This test method is used to determine the amount of contraction a yarn or cord undergoes after exposure to an aqueous solution.

X3.2 *Summary of Test Method*—The initial length of a specimen of yarn or cord that has been permitted to relax in a conditioned atmosphere is determined while under a specified force. After having been thoroughly wetted with water at room temperature, the length of the wet loaded specimen is measured after the length of the wet specimen becomes constant. The amount of contraction of the wet specimen is calculated from the difference in the observed lengths of the specimens before and after wetting.

X3.3 *Significance and Use*—Because textile materials are often subjected to aqueous media during their processing, it sometimes is necessary to know their behavior under such conditions.

X3.4 *Apparatus*:

X3.4.1 *Length-Measuring Device*, made of corrosion-resistant material upon which test specimens at least 250 mm (10 in.) long can be secured with one end of each specimen in a fixed position and can be immersed in water. The device shall be equipped with a means for measuring the initial length and final length of each specimen. This device shall be such that a tension force can be attached to the free end of each specimen in such a manner that there shall be no change in twist.

X3.4.2 *Tank*, made of corrosion-resistant material and of suitable dimensions for immersing in water the device described in X3.4.1 with the specimens of yarn or cord.

X3.4.3 *Tensioning Device*, clamps of a corrosion-resistant material.

X3.5 *Preparation of Specimens*—Test five specimens. Wind a skein sample of yarn or cord from a package or remove

a tabby sample of the cord fabric from the board to which it may be attached. Permit the sample to condition while relaxed without kinking in the test atmosphere for a minimum of 16 h prior to testing.

X3.6 *Procedure*—Using the apparatus with dry clamps, secure one end of the specimen in one of the clamps, and apply A force of 5 ± 1 mN/tex (0.05 ± 0.01 gf/den) to the other end of the specimen in such a manner that there is no change in twist. Record the initial length of the specimen to the nearest 0.5 mm (0.02 in.). Immerse the apparatus with the specimen and weight in the water at a temperature of $24 \pm 2^\circ\text{C}$ ($75 \pm 2^\circ\text{F}$). Expose the specimen until the rate of contraction of the specimen is less than 5 % of the shrinkage/min. Record the final length of the loaded specimen to the nearest 0.5 mm (0.02 in.) while it is wet.

X3.7 *Calculation*:

X3.7.1 Calculate the contraction of each wet specimen using Eq X3.1:

$$C = [(L_o - L_f)/L_o] \times 100 \quad (\text{X3.1})$$

where:

C = contraction of wet yarn or cord, %,
 L_o = initial length of specimen, mm (in.), and
 L_f = final length of specimen, mm (in.).

X3.7.2 Calculate the contraction for the sample to the nearest 0.1 % as the average contraction of the specimen.

X3.8 *Report*:

X3.8.1 State that the specimens were tested as directed in Appendix X3 of Test Methods D 885. Describe the material or product sampled and the method of sampling used.

X3.8.2 Report the option or procedure used, the number of specimens tested, and the contraction for the sample.

X4. SI CALCULATION

X4.1 To explain the SI-units to be used preferably for breaking toughness, work-to-break, and specific-work to-break, the following example may be helpful:

X4.2 Using a linear load-elongation curve (for the simplicity of the calculations, suppose a specimen has the following properties):

	Yarn	Cord
Linear density, tex	100	400
Breaking load, N	80	320
Breaking tenacity, mN/tex	800	800
Breaking extension, %	10	30
Breaking extension, mm (based on 250 mm gage length)	25	75

X4.3 Calculate the three properties in X5.3 as follows:

X4.3.1 *Work-to-Break*:

for yarn: $\frac{1}{2} \times 80 \text{ N} \times 0.025 \text{ m} = 1.00 \text{ N} \times \text{m} = 1.00 \text{ J}$
 for cord: $\frac{1}{2} \times 320 \text{ N} \times 0.075 \text{ m} = 12.0 \text{ N} \times \text{m} = 12.0 \text{ J}$

X4.3.2 *Specific-Work-to-Break* (work-to-break divided by the gage length):

for yarn: $(1.00 \text{ J}/0.25 \text{ m}) = 4.00 \text{ J/m}$
 for cord: $(12.0 \text{ J}/0.25 \text{ m}) = 48.0 \text{ J/m}$

X4.3.3 *Breaking Toughness* (specific-work-to-break divided

by the linear density):

for yarn: $4.00 \text{ J/m}/100 \text{ tex} = 4.00 \text{ J/m} \times 1000 \text{ m}/100 \text{ g} = 40 \text{ J/g}$
 for cord: $48.0 \text{ J/m}/400 \text{ tex} = 48.0 \text{ J/m} \times 1000 \text{ m}/400 \text{ g} = 120 \text{ J/g}$

X4.4 From this example, it is clear that the following units are preferred:

Work-to-break	J
Specific work-to-break	J/m
Toughness	J/g

X5. BIBLIOGRAPHY OF TIRE CORD TEST METHODS

NOTE X5.1—The Bibliography of Tire Cord Test Methods covers the following journals: (1) *Journal of Applied Polymer Science*, January 1959–August 1970, (2) *Journal of Polymer Science*, January 1950–December 1963, General Papers, January 1963–December 1965, *Polymer Physics Part A-2*, January 1965–September 1970, *Polymer Symposia Part C*, January 1963–August 1970, (3) *Journal of the Textile Institute Transactions*, January 1950–August 1970, (4) *Textile Research Journal*, January 1950–September 1970, and (5) Other journals at random.

X5.1 Adhesion

Eccher, S., and Canevari, C., “Improvement of the Testing Method for Adhesion of Vulcanized Rubber to Steel Wire Cords,” *D.K.G. Rubber Conference*, 1968.

Iyengar, “Factors in Rubber Tire Cord Adhesion,” *Rubber World*, RUBWA, 1963, pp. 39–42.

Kenyon, D., “Laboratory Assessments of Fatigue Resistance and Dynamic Adhesion of Tyre Cords,” *Proceedings of the Institution of Rubber Industry*, PIRIA, Vol 11, No. 3, 1964, pp. 67–93.

Kenyon, D., “Laboratory Assessment of Tyre Cord Adhesion,” *Transactions of the Institution of Rubber Industry*, TIRIA, Vol 38, No. 4, 1964, T1650179.

Takeyama, J., and Matsui, J., “Recent Developments with Tire Cords & Cord to Rubber Bonding,” *Rubber, Chemistry, and Technology*, RCTEA, Vol 42, No. 1, 1969, pp. 159–256.

Tsydzik, M. A., Lukomskaya, A. I., and Slonimskii, G. L., “Dynamic Methods for Determination of Bond Strength Between Rubbers & Between Rubber & Cord,” *Rubber, Chemistry, and Technology*, RCTEA, Vol 33, 1960, pp. 42–50.

“U-Adhesion Test Fixture,” *Rubber Age*, RUAGA, Vol 91, No. 4, 1962, p. 676.

Wijngaarden, J. K., Van, “The Performance of Cord-in-Rubber Tests and the Treatment of the Test Results,” *D.K.G. Rubber Conference*, 1960.

X5.2 Birefringence

Heyn, A. N. J., “Observations of the Birefringence and Refractive Index of Synthetic Fibers with Special Reference to their Identification,” *Textile Research Journal*, TRJOA, Vol 22, 1952, pp. 513–522.

Sakajiri, S., “The Transition of Polyethylene Terephthalate Fiber Birefringence,” *Journal of Polymer Science*, Vol 35, No. 129, 1959, pp. 543–546.

X5.3 Breaking Time

“Hot Load Test,” Test Procedure FD9-1, The Goodyear Tire & Rubber Co., Akron, OH 1964.

Warburton, F. L., James, J. F. P., and Hother-Lushington, “Some Visco-Elastic Properties of Nylon,” *British Journal of Applied Physics*, BJAPA, Vol 12, 1961, p. 230.

X5.4 Compression Testing

Bhakuni, R. S., Gingo, J. M., and Causa, A. G., *Tire Fiber Rheology*, The Goodyear Tire & Rubber Company, Akron, OH, 1970.

Bobeth, W., “Automatic Textile Testing by Electronic Data Scanning and Evaluation by an Axial Pressure Tester,” *Faserforschung Und Textiltechnik*, FSTXA, Vol 21, No. 11, 1970, pp. 453–459.

Friedemann, W., “Simple Method for Measuring the Stress in Compressed Cord Yarns,” *Faserforschung Und Textiltechnik*, FSTXA, Vol 9, No. 8, 1958, pp. 334–337.

Wolf, B. M., and Armstrong, R. R., *Testing Cord Fabric*, Firestone Tire & Rubber Co., U.S.P. 1954, 2665582.

X5.5 Contact-Angle

Grindstaff, T. H., “A Simple Apparatus and Technique for Contact Angle Measurements on Small-Denier Single Fibers” *Textile Research Journal*, TRJOA, Vol 39, 1969, pp. 958–962.

X5.6 Creep

Howard, W. H., and Williams, M. L., “The Viscoelastic Properties of Oriented Nylon 66 Fibers,” *Textile Research Journal*, TRJOA, Vol 33, 1963, pp. 689–698.

X5.7 Crimp

Brand, R. H., and Kende, P., “Measurement of Three-Dimensional Fiber Crimp,” *Textile Research Journal*, TRJOA, Vol 40, 1970, pp. 169–177.

X5.8 Crystallinity

Bosley, D. E., “X-Ray Determination of Crystallinity in Poly(Ethylene Terephthalate),” *Journal of Applied Polymer Science*, JAPNA, Vol 8, 1964, pp. 1521–1529.

Hobbs, S. Y., and Mankin, G. I., “Determination of Polymer Crystallinities from Thermal Measurements,” *Journal of Polymer Science*, Part A-2, No. 9, 1971, pp. 1907–1910.

Miller, R. G., and Willis, H. A., “An Independent Measurement of the Amorphous Content of Polymers,” *Journal of Polymer Science*, Vol 19, 1956, pp. 485–494.

X5.9 Cut Resistance

Settle, G. E., and Anderson, S. L., “Resistance to Rupture of

Single Fibers Under Transverse Pressure," *Journal of The Textile Institute Transactions*, JTITA, Vol 54, T28, 1963.

X5.10 Denier

Bloch, M. G., and Gusack, J. A., "Denier Distribution of Textile Fibers Obtained with an Electrical Sensing Zone Particle Analyzer (Coulter Counter)," *Textile Research Journal*, TRJOA, Vol 33, 1963, pp. 224–233.

X5.11 Differential Thermal Analysis

Keavney, J. J., and Eberlin, E. C., "The Determination of Glass Transition Temperatures by Differential Thermal Analysis," *Journal of Applied Polymer Science*, JAPNA, Vol 3, No. 7, 1960, pp. 47–53.

Schwenker, R. F., Jr., and Zuccarello, R. K., "Differential Thermal Analysis of Synthetic Fibers," *Journal of Polymer Science*, Part C, No. 6, 1964, pp. 1–16.

Strella, S., "Differential Thermal Analysis of Polymers," *Journal of Applied Polymer Science*, JAPNA, Vol 7, 1963, pp. 569–579.

X5.12 Dip Pickup

Todd, H. E., and Tramutt, H. M., "Flame Photometric Determination of Rubber Solids Deposited on Cords & Fabrics," *Rubber Age*, RUAGA, New York, Vol 73, 1953, p. 501.

X5.13 Dynamic Modulus

Ballow, J. W., and Smith, J. C., "Dynamic Measurements of Polymer Physical Properties," *Journal of Applied Physics*, JAPIA, Vol 20, 1949, pp. 493–502.

Chaikin, M., and Chamberlain, N. H., "The Propagation of Longitudinal Stress Pulses in Textile Fibers—Part I," *Journal of the Textile Institute Transactions*, JTITA, Vol 46, 1955, pp. T25–43.

Dunell, B. A., and Dillon, J. H., "The Measurement of Dynamic Modulus & Energy Losses in Single Textile Filaments Subjected to Forced Longitudinal Vibrations," *Textile Research Journal*, TRJOA, Vol 21, 1951, pp. 393–403.

Hamburger, W. J., "Mechanics of Elastic Performance of Textile Materials," *Textile Research Journal*, TRJOA, Vol 18, 1948, pp. 705–743.

Kainradl, P., and Handler, F., "Dynamic Testing Methods for Tyre Cord," *Faserforschung Und Textiltechnik*, FSTXA, Vol 11, No. 9, 1960, pp. 408–427.

Lyons, W. J., and Prettyman, I. B., "Measurement of the Dynamic Stretch-Modulus and Hysteresis of Tire Cords," *British Journal of Applied Physics*, BJAPA, Vol 18, 1947, pp. 586–587.

Lyons, W. J., and Prettyman, I. B., "Method for the Absolute Measurement of Dynamic Properties of Linear Structures at Sonic Frequencies," *Journal of Applied Physics*, Vol 19, 1948, pp. 473–480.

Meredith, R., and Hsu, B. S., "Dynamic Bending Properties of Fibers: Effect of Temperature on Nylon 66, Terylene, Orlon, & Viscose Rayon," *Journal of Polymer Science*, Vol 61, 1962, pp. 271–292.

Mieck, et al, "Static and Dynamic Cord Tests," *Faserforschung und Textiltechnik*, FSTXA, Vol 13, (11), 1962, pp. 502–511.

Palandri, G., "Measurement of Hysteresis and Dynamic Elastic Modulus of Textile Yarns and Cords," *Rubber Age*, 64, 1948, pp. 45–52.

Sakurada, I., Nukushina, Y., and Ito, T., "Experimental Determination of the Elastic Modulus of Crystalline Regions in Oriented Polymers," *Journal of Polymer Science*, Vol 57, 1962, pp. 651–660.

Smith, H. D., and Jenkins, R. C., "Cord Modulus: New Cord Extension System," *Rubber Age*, RUAGA, Vol 95, No. 4, 1964, p. 575.

Rubber World, RUBWA, Vol 95, No. 4, 1964, p. 90.

Tipton, H., "The Dynamic Tensile Mechanical Properties of Textile Filaments and Yarns," *Journal of the Textile Institute Transactions*, Vol 46, 1955, pp. T322–361.

Tokita, N., "The Effects of Crystallization and Drawing on the Viscoelastic Properties of Fibers," *Journal of Polymer Science*, Vol 20, 1956, pp. 515–536.

Van der Meer, S. J., "Dynamic Measurement on Textile Yarns, Industrial Yarns and Tire Cords," AKU Research Report No. R1209, 1965, AKU, Arnhem, Netherlands. "Modulus Tester," *Rubber World*, RUBWA, Vol 148, No. 2, 1963, p. 22.

X5.14 Elastic Recovery

Hearle, J. W. S., and Plonsker, H. R., "Behavior of Fibers in Cumulative Extension Cycling," *Journal of Applied Polymer Science*, Vol 10, 1966, pp. 1949–1971.

X5.15 Elongation

Breazeale, F. B., and Irvin, H. D., "An Automatic Yarn Load-Elongation Recorder," *Textile Research Journal*, TRJOA, Vol 22, 1952, pp. 549–552.

Meredith, R., "The Effect of Rate of Extension on the Tensile Behavior of Viscose and Acetate Rayons, Silk and Nylon," *Journal of the Textile Institute Transactions*, JTITA, Vol 45, 1954, pp. T30–43.

Orr, R. S., and Grant, J. N., "A Single-Fiber Load-Elongation Tester for Cotton," *Textile Research Journal*, TRJOA, Vol 23, 1953, pp. 505–509.

Wood, J. O., and Kilby, W. F., "An Apparatus for the Measurement of the Delayed Elongation of Tyre Cords," *Journal of the Textile Institute Transactions*, JTITA, Vol 49, 1958, pp. T89–94.

X5.16 Fatigue

Bartha, Z., "Evaluating Tyre Cords," *Man-Made Textiles*, MMTXA, Vol 38, May 1961, p. 57.

Bartha, Z., "Fatigue Testing of Tyre Cord Yarns in Rubber," *Muanyag*, MUANA, Vol 1, No. 7, 1964, pp. 212–215.

Bartha, Z., "Tyre Cord Fatigue Tests," *Rev. Gen. Caout. Plast.*, Vol 44, No. 10, 1967, pp. 1205–1212.

Buchan, J., "Fatigue Testing of Tyre Cords in Rubber," *Textile Weekly*, TEWEA, Vol 58, 1958, pp. 315–316.

Budd, C. B., "A Fatigue Test for Tire Cord," *Textile Research Journal*, TRJOA, Vol 21, 1951, pp. 174–179.

Dischka, G., and Hajmasy, T., "Fatigue Tests on Tyre Cords," *Acta Technica*, Vol 38, 1962, pp. 235–257.

Falch, W., "Dynamic Fatigue Tests on Tyre Cord in Combination with Rubber," *DKG Rubber Conference*, 1956.

Floyd, K. L., "The Behavior of Rayon Tyre Cords Under

Compressive Flexing," *Journal of the Textile Institute Transactions*, JTITA, Vol 53, No. 10, 1962, pp. T449-663.

Forster, M. J., and Prettyman, I. D., "New Improved Tyre Cord Fatigue Tester," *Rubber, Chemistry, and Technology*, RUAGA, Vol 42, No. 4, 1969, pp. 1000-1008.

Frank, F., and Singleton, R. W., "A Study of Factors Influencing the Tensile Fatigue Behavior of Yarns," *Textile Research Journal*, Vol 34, 1964, pp. 11-19.

Gibson, E. C., "Tyre Cord Testing Machine," American Viscose Corp., U.S. Patent 2916912, 1959.

Hannell, J. W., "Tire Testing," *ASME Publications*, 59-SA-48, New York 1959.

Hofferberth, W., "Static and Dynamic Testing of Textiles and Its Practical Importance," *DKG Rubber Conference*, 1954.

Kemnitz, "A Study of the Compression Fatigue and the Damping Phenomena of Tire Cord," *Journal of Applied Polymer Science*, TAPNA, Vol 32, 1962, pp. 373-392.

Kenyon, D., "Laboratory Assessments of Fatigue & Dynamic Adhesion of Tyre Cords," *Proc. I.R.I.*, Vol 11, No. 3, 1964, pp. 67-93.

Kenyon, D., "Tyre Cord Fatigue Testers," *British Nylon Spinners Outlook*, No. 13, 1964.

Lincoln, B., "Flexural Fatigue and Visco-Elastic Properties of Wool Fibers," *Journal of the Textile Institute Transactions*, JTITA, Vol 43, 1952, pp. T158-172.

Lockwood, P. A., Edmunds, W. M., and Grimm, G. W., "Fatigue Performance of Tire Belt Cords," *Rubber, Chemistry, and Technology*, RCTEA, Vol 44, No. 4, 1971, pp. 946-951.

Lyons, W. J., "Fatigue in Textile Fibers, Part I," *Textile Research Journal*, TRJOA, Vol 32, 1962, pp. 448-459.

Lyons, W. J., "Fatigue in Textile Fibers, Part III," *Textile Research Journal*, TRJOA, 1962, pp. 750-761.

Lyons, W. J., "Fatigue in Textile Fibers, Part IX," *Textile Research Journal*, TRJOA, Vol 35, 1965, pp. 1106-1109.

Lyons, W. J., "Fatigue in Textile Fibers, Part XI," *Textile Research Journal*, TRJOA, Vol 40, 1970, pp. 60-68.

Lyons, W. J., "Fatigue in Textile Fibers, Part XII," *Textile Research Journal*, TRJOA, Vol 20, 1970, pp. 836-843.

Mieck, K. P., "Testing the Fatigue Behavior of Tyre Cord Vulcanized into Rubber," *Faserforschung Und Textiltechnik*, FSTXA, Vol 10, No. 12, 1959, pp. 578-587.

Ono, et al, "On the Fatigue Mechanism of Tire Cord," *Journal of the Society of Textile and Cellulose Industries of Japan*, SENGA, Vol 18, 1962, pp. 955-962.

Prevorsek, D. C., and Lyons, W. J., "Endurance of Polymeric Fibers in Cyclic Tension," *Rubber, Chemistry, and Technology*, RCTEA, Vol 44, No. 1, 1971, pp. 271-293.

Rhodes, T. J., "Apparatus for Testing Cord Fatigue," *U.S. Rubber Co.*, U.S. Patent 2612040, 1952.

Shirakashi, K., and Ishikawa, K., "Study on Tyre Cords," *Journal of the Society of Textile and Cellulose Industries of Japan*, SENGIA, Vol 12, 1956, pp. 392-397.

Stroenov, U. B., Denisenko, N. V., and Nemchenko, E. A., "Determination of the Fatigue Properties of (Tire) Cord Subjected to Repeated Deformation of Modernized Apparatus of the 5-24-1-Tyre," *Khim. Volok.*, No. 6, 1962, pp. 31-34.

Wegener, W., "Apparatus for Testing Dynamic Fatigue with Superimposed Alternating Load," *Melliand Textillerberichte*,

MTEEA, Vol 35, 1954, pp. 371-374.

Wegener, W., "Fatigue Testing Devices for Yarns and Fabrics," *Melliand Textilberichte*, MTEEA, Vol 39, No. 1, 1958, pp. 17-21.

Wilson, N. W., "Tire-Cord Compression Fatigue," *Textile Research Journal*, TRJOA, Vol 21, 1951, pp. 47-54.

"Apparatus for Testing the Flexing Fatigue of Tyre Cords," Japanese Patent 5398159.

"B. F. Goodrich Disc. Compression Cord Tester," *Rubber Age*, RUAGA, Vol 78, 1955, p. 299.

"Fatigue Tester for Cord," *Rubber Age*, RUAGA, Vol 102, No. 5, 1970, pp. 125-128.

"Tire Cord Tester," *Rubber World*, RUBWA, Vol 144, No. 5, 1961, p. 62; *Rubber Age*, RUAGA, Vol 90, No. 1, 1961, p. 154.

X5.17 Flatspotting

Claxton, W. E., Forster, M. J., Robertson, J. J., and Thurman, G. R., "Correlation of Nylon Tire Cord Properties with Tire Flatspotting," *Textile Research Journal*, TRJOA, Vol 36, 1966, pp. 903-914.

Jonson, C. A., "Apparatus for Measuring Elastic Properties," U.S. Patent 3,062,044, 1962.

Oswald, H. J., Papero, P. V., and Winckhofer, R. C., "The Mechanism of Flatspotting and Its Relation to Fiber Properties," *Rubber, Chemistry, and Technology*, RCTEA, Vol 38, No. 4, November 1965.

Rye, G. W., and Martin, J. E., "Lab Test to Predict Flatspotting Behavior of Tyre Cord," *Rubber World*, Vol 148, No. 1, 1963, p. 76.

X5.18 Friction

Grosberg, P., and Plate, D. E. A., "Capstan Friction for Polymer Monofilaments with Rigidity," *Journal of the Textile Institute Transactions*, JTITA, Vol 60, 1969, pp. 268-283.

Guthrie, J. C., and Oliver, P. H., "Inter-Fiber Friction of Viscose Rayon," *Journal of the Textile Institute Transactions*, JTITA, Vol 43, pp. T579-94.

Hadley, D. W., "The Resistance to Abrasion Against Fine India Stone of Single Filaments of Polyethylene Terephthalate and Polypropylene," *Journal of the Textile Institute Transactions*, JTITA, Vol 54, 1963, pp. T-409-419.

Howell, H. G., "Inter-Fiber Friction," *Journal of the Textile Institute Transactions*, JTITA, Vol 42, 1951, pp. T521-333.

King, G., "Some Frictional Properties of Wool and Nylon Fibers," *Journal of the Textile Institute Transactions*, JTITA, Vol 41, 1950, pp. T135-144.

Lyons, W. J., and Scheier, S. C., "Measurement of the Surface Friction of Fibers by an Electro-Mechanical Method," *Textile Research Journal*, Vol 35, 1965, pp. 385-394.

Olsen, J. S., "Frictional Behavior of Textile Yarns," *Textile Research Journal*, TRJOA, Vol 39, 1969, pp. 31-37.

Schlatter, C., and Demas, H. J., "Friction Studies on Caprolan Filament Yarn," *Textile Research Journal*, TRJOA, Vol 32, 1962, p. 8798.

Susich, G., "Abrasion Damage of Textile Fibers," *Textile Research Journal*, TRJOA, Vol 24, 1954, pp. 210-228.

X5.19 Gage

VanGijzen, A., "Tyre Cord Gauge Measurement," *Rayon*

Revue, RYSIA, Vol 10, No. 5, 1956, pp. 189–192.

VanIssum, B. E., and Chamberlain, N. H., “The Free Diameter and Specific Volume of Textile Yarns,” *Journal of the Textile Institute Transactions*, JTITA, Vol 50, 1959, p. T599.

X5.20 Hardness

Chakravarty, A. C., “Measurement of Hardness of Textile Fibers,” *Journal of the Textile Institute Transactions*, JTITA, Vol 45, 1954, pp. T723–729.

X5.21 Hysteresis

Wakeham, H., and Honold, E., “Mechanical Hysteresis Properties of Single Fibers & Cords,” *Textile Research Journal*, TRJOA, Vol 21, 1951, pp. 1–5.

X5.22 Impact Resistance

Ballou, J. W., and Roetling, J. A., “High Speed Tensile Testing of Fibers,” *Textile Research Journal*, TRJOA, Vol 28, 1958, pp. 631–646.

Cross, M. M., and Garrett, D. A., “High-Speed Fibre Extensometer,” *Journal of the Textile Institute Transactions*, JTITA, Vol 47, 1956, pp. T222–231.

Dickson, J. B., and Davieau, L. A., “Impact Tester for Textiles,” *ASTM Bulletin*, No. 198, 1954, p. 85.

Hall, I. H., “The Tensile Properties of Textile Yarns at Very High Strain Rates,” *Journal of Applied Polymer Science*, JAPNA, Vol 8, 1964, pp. 237–256.

Hamburger, W. J., “Time Effects on Textile Fibers,” *SPE Trans.*, 1964, p. 208.

Holden, G., “Tensile Properties of Textile Fibers at Very High Rates of Extension,” *Transactions*, JTITA, Vol 50, 1959, pp. T41–54.

Jameson, J. W., Stewart, G. M., Petterson, D. R., and Odell, F. A., “Dynamic Distribution of Strain in Textile Materials Under High-Speed Impact Part III,” *Textile Research Journal*, TRJOA, Vol 32, 1962, pp. 858–860.

Kerawalla, J. N., “Role of Cord Properties in Tire Impact Resistance,” *Materials Research and Standards*, MTRSA, Vol 10, No. 6, June 1970, pp. 15–19.

Lang, W. R., “Ballistic Determination of Work of Rupture of Short Textile Samples,” *Journal of the Textile Institute Transactions*, Vol 42, 1951, pp. T314–328.

Lothrop, E. W., “Tensile Properties of Yarns and Cords at High Rates of Extension,” FMC Corp., American Viscose Division, 1965.

Lothrop, E. W., “Stress-Strain Properties of Tire Cords as a Function of Temperature and Rate of Extension,” *Applied Polymer Symposia*, APPSA, Vol 1, 1965, pp. 111–124.

Lyons, W. J., “Impact Phenomena in Textiles,” 1963, M.I.T. Press, Cambridge, MA, pp. 21–71.

Lyons, W. J., and Prettyman, I. B., “Use of the Ballistic Pendulum for Impact Testing of Tire Cord,” *Textile Research Journal*, TRJOA, Vol 23, 1953, pp. 917–925.

Meredith, R., “The Effect of Rate of Extension on the Tensile Behavior of Viscose and Acetate Rayons, Silk, and Nylon,” *Journal of the Textile Institute Transactions*, Vol 45, 1954, p. T30.

O’Neil, K. B., Dague, M. F., and Kimmel, J. E., “High Speed Tensile Testing of Tire Textiles,” *Rubber, Chemistry, and*

Technology, RCTEA, Vol 41, No. 4, 1968, pp. 1045–1050.

Parker, J. P., and Kemic, C. S., “A Flywheel Impact Test for Measuring Physical Properties of Tire Cords,” *Journal of Applied Polymer Science*, JAPNA, Vol 6, No. 21, 1962, pp. 255–263.

Parker, J. P., and Kemic, C. S., “Impact Resistance of Rayon & Nylon Tire Cords,” *Rubber World*, RUBWA, Vol 138, 1958, p. 116.

Parker, J. P., and Kemic, C. S., “Flywheel Impact Test for Measuring Physical Properties of Tire Cords,” *High Speed Testing*, HSPT, Vol III, 1962, pp. 3–11.

Pavlov, N. N., Yaminskaya, E. Y., and Krymon, B. M., “Application of Strain Gages to the Study of (Tire) Cord at High Elongation Rates,” *Rubber, Chemistry, and Technology*, RCTEA, Vol 32, 1959, pp. 907–914.

Petterson, D. R., Stewart, G. M., Odell, F. A., and Maheux, R. C., “Dynamic Distribution of Strain in Textile Materials Under High Speed Impact Part I,” *Textile Research Journal*, TRJOA, Vol 30, 1960, pp. 411–421.

Pilsworth, M. N., Jr., “Tension Impact on Rubber and Nylon,” Quarter-Mast Research and Engineering Center, Natick, MA, Technical Report, PR-3, 1962.

Pilsworth, M. N., and Hoge, H. J., “Rate of Dependent Response of Polymers to Tensile Impact,” *Textile Research Journal*, TRJOA, Vol 35, 1965, pp. 129–139.

Schiefer, H. F., Appel, W. D., Krasny, J. F., and Richey, G. C., “Impact Properties of Yarns Made From Different Fibers,” *Textile Research Journal*, TRJOA, Vol 28, 1953, p. 489.

Schulman, S., “Evaluation Techniques for Fibrous Materials,” *Textile Research Journal*, Vol 36, 1966, pp. 673–81.

Selwood, A., “A Catapult Method for Extending Textile Filaments at High Rates,” *Journal of the Textile Institute Transactions*, JTITA, 1964, pp. T146–153.

Skelton, J., “Tensile Behavior of Fibrous Materials at High Rates of Strain & Sub Ambient Temperatures,” *Materials Research and Standards*, MTRSA, Vol 10, No. 6, 1970, pp. 20–25.

Smith, J. C., Fenstermaker, C. A., and Schouse, P. J., “Stress-Strain Relationships in Yarns Subjected to Rapid Impact Loading Part X,” *Textile Research Journal*, TRJOA, Vol 33, 1963, pp. 919–934.

Smith, J. C., Fenstermaker, C. A., and Schouse, P. J., “Stress-Strain Relationships in Yarns Subjected to Rapid Impact Loading Part XI,” *Textile Research Journal*, TRJOA, Vol 35, 1965, pp. 743–756.

Smith, J. G., McCrackin, F. L., Schiefer, H. F., Stone, W. K., and Towne, K. M., “Stress-Strain Relationships in Yarns Subjected to Rapid Impact Loading Part IV,” *Textile Research Journal*, TRJOA, Vol 26, 1956, pp. 821–828.

Stone, W. K., Schiefer, H. F., and Fox, G., “Stress-Strain Relationships in Yarns Subjected to Rapid Impact Loading Part I,” *Textile Research Journal*, TRJOA, Vol 25, 1955, pp. 520–528.

“High Speed Tensile Properties of Tire Cord,” Teijin, Ltd., 1965.

“Tyrex Test Measures Tyre Strength,” *Chemical and Engineering News*, CENEA, Vol 44, No. 42, 1966, pp. 72–73.

X5.23 Infrared Analysis

Knight, J. A., Smoak, M. D., and Kirkland, W. E., "Direct Pressing of Fibers for Infrared Spectroscopic Studies," *Textile Research Journal*, Vol 37, 1967, pp. 924–927.

X5.24 Intrinsic Viscosity

Gramain, P. H., and Libeyre, R., "Automatic Recording Capillary Viscosimeter with Dilution," *Journal of Applied Polymer Science*, JAPNA, Vol 14, 1970, pp. 383–391.

X5.25 Moisture

Collins, J. B., "Producing Ripple-Free Direct Potential," U.S. Patent 2849676.

Haase-Deyerling, et al, "New Dielectric Method for the Rapid Determination of the Moisture Content of Tire Cord," D.K.G. Rubber Conference, 1960.

Mess, E., and Mark, R. A., "Moisture Measuring Equipment," *Ind. Chem.*, Vol 38, No. 443, 1962, pp. 39–40.

X5.26 Orientation

Conrad, C. M., and Creely, J. J., "Apparatus for Use with the X-Ray Diffractometer to Determine the Degree of Crystallite Orientation in Fibers," *Textile Research Journal*, TRJOA, Vol 35, 1965, pp. 863–866.

Farrow, G., and Bagley, Miss J., "The Measurement of Molecular Orientation in Polyethylene Terephthalate Filaments by X-Ray Diffraction," *Textile Research Journal*, TRJOA, Vol 32, 1962, pp. 587–598.

X5.27 Reservoir

Jenkins, R. C., Meherg, J. W., and Linn, J. V., "The Cord Reservoir—A New Concept in the Mechanism of Tire Blows," The Goodyear Tire & Rubber Co., Akron, OH, 1963.

X5.28 Resilience

Hadley, D. W., "A Critical Comparison of Empirical Tests of the Extensional Resilience of Textile Fibers Part I," *Journal of the Textile Institute Transactions*, JTITA, Vol 60, 1969, pp. 301–311.

X5.29 Resonance Frequency

Hearle, J. W. S., and Turner, D. J., "A Preliminary Study of a Technique for Measuring Flexural Vibrations in Fabrics," *Textile Research Journal*, TRJOA, Vol 31, 1961, pp. 981–986.

X5.30 Solvation Resistance

"Solvation Resistance," Test Procedure FD14-1, The Goodyear Tire & Rubber Co., Akron, OH 1964.

"Tensilizing Tire Fabric of Golden Caprolan Nylon," Allied Chemical Corp., Fibers Division, Hopewell, 1963.

X5.31 Specific Heat

Haly, A. R., and Snaith, J. W., "The Specific Heat of Polyethylene Terephthalate (PET) and the Fusion of its Absorbed Water," *Textile Research Journal*, TRJOA, Vol 39, 1969, pp. 906–911.

X5.32 Staining

"Staining-Tire Cords," Test Procedure FD15-1, The Good-

year Tire and Rubber Co., Akron, OH, 1964.

X5.33 Stiffness

Abbott, G. M., and Grosberg, P., "Measurement of Fabric Stiffness and Hysteresis in Bending," *Textile Research Journal*, TRJOA, Vol 36, 1966, pp. 928–930.

Chen, C. S., and Zorowski, C. F., "Cantilever Bending Behavior of Continuous Filament Cords," *Textile Research Journal*, TRJOA, Vol 35, 1965, pp. 529–538.

Funsch, O. B., and Jenkins, R. C., "A New Technique for Measuring Tire Fabric Stiffness," The Goodyear Tire and Rubber Co., Akron, OH, 1965.

Kalkman, J. A., "Measuring the Flexural Rigidity of Woven Fabrics," *Enka and Breda Rayon Review*, EBREB, Vol 9, 1955, p. 9.

Livesay, R. G., and Owen, J. D., "Cloth Stiffness and Hysteresis in Bending," *Journal of the Textile Institute Transactions*, JTITA, Vol 55, 1964, p. T516.

Noser, S., "Apparatus for Measuring Bending Stress in Tyre Cords," *Textile*, TXTIA, Vol 13, No. 6, 1958, pp. 221–222.

Owen, J. D., "The Application of Searles Single and Double Pendulum Methods to Single Fiber Rigidity Measurements," *Journal of the Textile Institute Transactions*, JTITA, Vol 56, 1965, pp. T329–339.

Scott, G. V., and Robbins, C. R., "A Convenient Method for Measuring Fiber Stiffness," *Textile Research Journal*, TRJOA, Vol 39, 1969, pp. 975–976.

Stuart, I. M., and Baird, K., "A New Test for Bending Length," *Textile Research Journal*, TRJOA, Vol 36, 1966, pp. 91–93.

X5.34 Stiffness (Dynamic Bending Modulus)

Wakayama, K., and Jinen, E., "An Automatic Vibroscope and How to Use It," *Journal of the Textile Machinery Society of Japan*, Vol 16, No. 2, 1970, pp. 59–67.

X5.35 Strain Recovery (Elastic Recovery)

Zurek, W., and Godon, J., "Strain Recovery of Twisted Viscose Rayon," *Textile Research Journal*, TRJOA, Vol 41, 1971, pp. 984–990.

X5.36 Stress Relaxation

Herwig, H. U., "The Influence of Stress Relaxation Interval on the Tensile Behavior of Industrial Yarns," *Textile Research Journal*, TRJOA, Vol 41, 1971, pp. 366–368.

Kuba, E. T., "The Stress Relaxation of Fibrous Materials I. Instrumentation and Preliminary Results," *Textile Research Journal*, TRJOA, Vol 22, 1952, p. 765.

Meredith, R., and Hsu, B., "Stress Relaxation in Nylon and Terylene: Influence of Strain, Temperature and Humidity," *Journal of Polymer Science*, Vol 61, 1962, p. 253.

X5.37 Tensile Strength

Brown, G. L., "Fabric Testing Machine, Inclined Plane Type," *Journal of the Textile Institute Transactions*, Vol 43, 1952, pp. T119–121.

Checkland, D. B., Bull, T. H., and Baker, E. J., "A Two-Dimensional Load-Extension Tester for Fabrics and Film," *Textile Research Journal*, TRJOA, Vol 28, 1958, pp. 399–403.

Crane, R. A., and Wharff, P. C., Jr., "An Automatic Single Fiber Tensile Strength Tester," *Textile Research Journal*, TRJOA, Vol 28, 1958, pp. 343–350.

Dent, R. W., and Hearle, J. W. S., "The Tensile Properties of Twisted Single Fibers," *Textile Research Journal*, TRJOA, Vol 30, 1960, pp. 805–826.

Frank, F. I., and Ruoff, A. L., "A Method of Measuring Poisson's Ratio of Fibers," *Textile Research Journal*, TRJOA, Vol 28, 1958, pp. 213–217.

Frenzel, W., and Kittelman, W., "Tyre Cord Testing," *Faserforschung Und Textiltechnik*, FSTXA, Vol 8, No. 6, 1957, pp. 223–230.

Illingworth, J. W., and Kilby, W. F., "The Reversible Effect of Temperature on the Mechanical Properties of Tire Yarns and Cords," *Textile Research Journal*, TRJOA, Vol 26, 1956, pp. 243–254.

Klein, W. G., "Stress-Strain Response of Fabrics Under Two-Dimensional Loading, Part I," *Textile Research Journal*, TRJOA, Vol 29, 1959, pp. 816–821.

Klust, "The Knot-Tensile Strength of Ply Yarns and Cords Made of Synthetic Fibers," *Textil Praxis*, TEPPRA, Vol 17, No. 9, 1962, pp. 881–884.

Phillipson, "Tyre Cord Testing," *Skinner's Silk and Rayon Record*, SSRRA, 1959, pp. 970–994.

Preusser, H. M., O'Connell, R. A., Yeiser, A. S., and Lungren, H. P., "Single Fiber Stress-Strain Apparatus," *Textile Research Journal*, TRJOA, Vol 24, 1954, pp. 118–122.

"Cord Tensile Clamps," *Rubber World*, RUBWA, Vol 146, No. 3, 1962, p. 40, *Rubber Age*, RUAGA, Vol 92, No. 2, 1962, p. 315.

"Denison Tensile Test Machine," Dunlop-Rubber Co., Ltd., 1955.

"Scotomatic Model IP-4 Tester," *Textile, Mercury, and Argus*, TMARA, Vol 139, 1958, pp. 368–369.

X5.38 Thermal Conductivity

David, H. G., "A Simple Method of Measuring the Thermal Transmission of Fabrics," *Textile Research Journal*, Vol 33, 1963, p. 322.

X5.39 Thermal Shrinkage

Coe, A. B., Prevorsek, D. C., and Tobolsky, A. V., "A Microscopical Method for the Study of Free Thermal Shrinkage in Oriented Polymers," *Textile Research Journal*, TRJOA, Vol 32, 1962, pp. 960–962.

Prevorsek, D., and Tobolsky, A. V., "Determination of Non-Flow Shrinkage Ratio in Oriented Fibers," *Textile Research Journal*, TRJOA, Vol 33, 1963, pp. 798–802.

Ribnick, A., "Thermal Shrinkage of Oriented Nylon 66 Yarns as a Function of Time, Temperature, and Stress," *Textile Research Journal*, TRJOA, Vol 39, 1969, pp. 428–434.

X5.40 Torsional Rigidity

Goodings, A. C., "A Method for the Measurement of the Rigidity of Fibers Immersed in Liquids: The Torsion Double Pendulum," *Textile Research Journal*, TRJOA, Vol 38, 1968, pp. 123–129.

Meredith, R., "The Torsional Rigidity of Textile Fibers," *Journal of the Textile Institute Transactions*, JTITA, Vol 45, 1954, pp. T489–503.

Middelburg, P. H., "A Method for the Measurement of the Rigidity of Fibers Immersed in Liquids," *Textile Research Journal*, TRJOA, Vol 38, 1968, p. 1138.

Nordon, P., "Rotational Vibroscope for the Comparison of the Torsional Properties of Thin Fibers," *Journal of Scientific Instruments*, JSINA, Vol 38, 1961, pp. 349–354.

Skelton, J., "The Measurement of the Torsional Elastic Recovery of Filaments," *Journal of the Textile Institute Transactions*, JTITA, Vol 56, 1965, pp. T443–453.

X5.41 Twist

Batcheler, F. D., "Automatic Measurement of Folding Twist on Two-Ply Yarn," *Journal of the Textile Institute Transactions*, JTITA, Vol 61, 1970, pp. 221–231.

Denisora, et al, "Improving the Properties of Viscose Cord in the Twisting Process," *Khimickeskie Volokna*, KATRA, No. 6, 1962, pp. 25–27.

Frenzel, W., "Determination of Twist & Untwisted Length of Tyre Cord," *Faserforschung Und Textiltechnik*, FSTXA, Vol 2, No. 12, 1951, pp. 481–483.

Treloar, Mather, "Twisted Structures," *Journal of the Textile Institute, Proceedings*, JITPA, 1964, pp. P13–26.

Uno, and Shiomi, "Continuous Twist Irregularity Tester," *Textile Research Journal*, TRJOA, 1957, pp. 818–824.

X5.42 Uniformity

Prins, I., "Determination of the Irregularity of Filament Yarns," *Enka and Breda Rayon Review*, EBREB, Vol 9, 1965, p. 1.

Uno, M., Saito, H., Shiomi, A., and Hiramatu, T., "Photoelectric Twist Irregularity Tester," *Textile Research Journal*, TRJOA, Vol 29, 1959, pp. 550–557.

"A Twist Irregularity Meter for Tire Cord," *Enka Breda Rayon Revue*, EBREB, Vol 9, No. 3, 1955, pp. 81–87.

X5.43 Wettability

Dyba, R. V., and Miller, B., "Dynamic Measurements of the Wetting of Single Filaments," *Textile Research Journal*, TRJOA, Vol 40, 1970, pp. 884–890.

The American Society for Testing and Materials takes no position respecting the validity of any patent rights asserted in connection with any item mentioned in this standard. Users of this standard are expressly advised that determination of the validity of any such patent rights, and the risk of infringement of such rights, are entirely their own responsibility.

This standard is subject to revision at any time by the responsible technical committee and must be reviewed every five years and if not revised, either reapproved or withdrawn. Your comments are invited either for revision of this standard or for additional standards and should be addressed to ASTM Headquarters. Your comments will receive careful consideration at a meeting of the responsible technical committee, which you may attend. If you feel that your comments have not received a fair hearing you should make your views known to the ASTM Committee on Standards, at the address shown below.

 **D 885**

This standard is copyrighted by ASTM, 100 Barr Harbor Drive, PO Box C700, West Conshohocken, PA 19428-2959, United States. Individual reprints (single or multiple copies) of this standard may be obtained by contacting ASTM at the above address or at 610-832-9585 (phone), 610-832-9555 (fax), or service@astm.org (e-mail); or through the ASTM website (www.astm.org).