



Standard Test Method for Snagging Resistance of Fabrics (Bean Bag)¹

This standard is issued under the fixed designation D 5362; the number immediately following the designation indicates the year of original adoption or, in the case of revision, the year of last revision. A number in parentheses indicates the year of last reapproval. A superscript epsilon (ϵ) indicates an editorial change since the last revision or reapproval.

1. Scope

1.1 This test method determines the snagging resistance of a fabric.

1.2 Studies of fabric snagging have shown that this test method is suitable for a range of woven and knitted fabrics made from textured or untextured filament yarns or spun yarns or combinations of these yarns.^{2,3} This test method is not suitable for (1) open construction fabrics (such as a net) because the pins in the test chamber will snag the bean bag rather than the specimen, (2) heavy or stiff fabrics that cannot be made into a cover for the bean bag, and (3) tufted or nonwoven fabrics because the apparatus is designed for woven and knitted fabrics.

1.3 The values stated in either acceptable metric units or in other units shall be regarded separately as standard. The values stated in each system may not be the exact equivalents; therefore, each system must be used independently of the other, without combining values in any way. In case of referee decisions the metric units will prevail.

1.4 *This standard does not purport to address all of the safety concerns, if any, associated with its use. It is the responsibility of the user of this standard to establish appropriate safety and health practices and determine the applicability of regulatory limitations prior to use.* Specific precautionary statements are given in Section 7.

2. Referenced Documents

2.1 ASTM Standards:

- D 123 Terminology Relating to Textiles⁴
- D 1335 Test Method for Tuft Bind of Pile Floor Coverings⁴
- D 1776 Practice for Conditioning Textiles for Testing⁴
- D 2724 Test Methods for Bonded, Fused, and Laminated Apparel Fabrics⁴
- D 3136 Terminology Relating to Care Labels for Textile

and Leather Products Other Than Textile Floor Coverings and Upholstery⁴

D 3939 Test Method for Snagging Resistance of Fabrics (Mace)⁵

D 4467 Practice for Interlaboratory Testing of a Textile Test Method That Produces Non-Normally Distributed Data⁵

2.2 AATCC Standards:⁶

65 Test Method for Snag Resistance of Women's Nylon Hosiery (see Note 1)

135 Test Method for Dimensional Changes in Automatic Home Laundering of Woven and Knit Fabrics

NOTE 1—In 1988 the AATCC voted to withdraw this test method from their technical manual; however, the ASTM task group on fabric snagging decided it should be listed as an alternative for testing open construction fabrics.

3. Terminology

3.1 Definitions:

3.1.1 *color contrast, n—in textiles*, a general term for a visible color difference between two adjacent areas.

3.1.1.1 *Discussion*—For the purpose of this test method, a color contrast is a visible color difference between a snag and the immediate surrounding area of the fabric that has no defects. Color contrasts often occur when printed fabrics are snagged.

3.1.2 *distortion, n—in fabrics*, a general term for a visible defect in the texture of a fabric.

3.1.2.1 *Discussion*—For the purpose of this test method, snags are composed of different combinations of protrusions and distortions. A distortion is characterized by a group of fibers, a yarn, or a yarn segment that is displaced from its normal pattern so that there is a visible change in the texture of the fabric; however, the displaced group of fibers, yarn, or yarn segment does not extend above the fabric surface. Distortions include conditions where (1) tension on a snagged yarn has changed the size of some of the loops within a knitted fabric and the result is a pucker on the surface of the fabric, and (2) tension on a snagged yarn has caused the yarn to break off within a woven fabric and the result is a change in the texture where the yarn used to be.

3.1.3 *protrusion, n—in fabrics*, a general term for a visible

¹ This test method is under the jurisdiction of ASTM Committee D-13 on Textiles and is the direct responsibility of Subcommittee D13.59 on Fabric Test Methods, General.

Current edition approved Dec. 10, 1997. Published August 1998. Originally published as D 5362 – 93. Last previous edition D 5362 – 97.

² Stuckey, W. C., and El Shiekh, A., "Snags in Snag Testing of Knits", in *Sense and Nonsense in Knit Testing*, American Association of Textile Chemists and Colorists, 1975, pp. 45–53.

³ Cary, R. T., "Bean Bag Snag Tester: A System of Evaluation", *Textile Research Journal*, Vol 51, No. 2, 1981, pp. 61–63.

⁴ *Annual Book of ASTM Standards*, Vol 07.01.

⁵ *Annual Book of ASTM Standards*, Vol 07.02.

⁶ Available from American Association of Textile Chemists and Colorists, P.O. Box 12215, Research Triangle Park, NC 27709.

group of fibers, a yarn, or a yarn segment that extends above the fabric surface.

3.1.4 *snag, n—in fabrics*, a yarn or part of a yarn pulled or plucked from the surface.

3.1.4.1 *Discussion*—For the purpose of this test method, a snag is created when an object pulls, plucks, scratches, or drags a group of fibers, a yarn, or a yarn segment from its normal pattern. Snags can be classified into three types: (1) snags that have a protrusion and no distortion, (2) snags that have a distortion and no protrusion, and (3) snags that have both a protrusion and a distortion. Other changes in appearance, such as color contrasts, should be reported because they affect the visibility of a protrusion or a distortion.

3.1.5 *snagging resistance, n—in textile fabrics*, the property of a material whereby yarns or parts of yarns are prevented or inhibited from being pulled or plucked from the surface.

3.1.6 For definitions of other textile terms used in this test method, refer to Terminology D 123.

4. Summary of Test Method

4.1 A fabric specimen is made into a cover for a bean bag. Then the specimen and bean bag unit is tumbled for 100 revolutions in a cylindrical test chamber fitted on its inner surface with rows of pins. The degree of fabric snagging is evaluated by (1) comparison of the tested specimens with visual rating standards that may be either snagged fabrics or photographs of snagged fabrics, or (2) using a point system. The resistance to snagging is rated on a numerical scale ranging from 5 (no or insignificant snagging) to 1 (very severe snagging).

5. Significance and Use

5.1 *Acceptance Testing*—This test method may be used for acceptance testing of commercial shipments of fabrics because the precision is acceptable (see 15.1).

5.1.1 In case there are disputable differences between reported test results for two laboratories (or more), comparative tests should be performed to determine if there is a statistical bias between them, using competent statistical assistance. As a minimum, specimens should be used that are as homogeneous as possible, that are drawn from the material from which disputable test results were obtained, and that are randomly assigned in equal numbers to each laboratory for testing. The test results from the two laboratories should be compared using an appropriate statistical test for unpaired data, at a probability level chosen prior to the testing series. If a bias is found, either its cause must be found and corrected, or future test results must be adjusted in consideration of the known bias.

5.2 This test method may be used for quality control testing of fabrics during manufacturing and product comparisons of different fabrics by manufacturers, retailers, and users. This test method may also be used by researchers to examine the effect of new fibers, yarns, fabric constructions, and finishes on the snagging resistance of fabrics.

5.3 This test method may be used to test the snagging resistance of most apparel and home furnishings fabrics. Modifications of this test method (see 5.3.1), or a different test method (see 5.3.2 and 5.3.3), may be needed for different types of fabrics and different end-uses (such as towels, swimwear,

slacks, and upholstery).

5.3.1 For a specific fabric, if the test results from this test method do not correspond with the test results from a wear test then (1) the procedure described in Section 12 or (2) the evaluation described in Section 13 can be modified. For example, the number of revolutions of the test chamber for testing each specimen can be increased for a fabric that had a higher degree of snagging in a wear test than the same fabric had using the procedure described in Section 12. The purchaser and the supplier must agree to all changes in the procedure for operating the apparatus or for evaluating the test results.

5.3.2 Some fabrics which may not be suitable for this test method are described in 1.2. Many open construction fabrics can be tested for snagging resistance using AATCC Test Method 65. Many heavy or stiff fabrics can be tested for snagging resistance using Test Method D 3939. The snagging resistance of many pile floor coverings can be tested by Test Method D 1335.

5.3.3 When the purchaser and the supplier agree that the test results from the bean bag test method do not correspond with the test results from a wear test, Test Method D 3939 can be used.

5.4 Because fabric snagging can be affected by laundering or drycleaning, it may be advisable to test the snagging resistance of a fabric before and after laundering or drycleaning.

5.5 The snagging resistance of a specific fabric varies with individual wearers and general conditions of use. Therefore, it can be expected that garments of the same fabric will show a fairly wide snagging resistance spectrum after wear and much greater variation in wear than in replicate fabric specimens subjected to controlled laboratory tests. This factor should be considered when adopting levels of acceptability for any specification that includes snagging resistance.

5.6 Snags observed in worn garments vary appreciably in number and appearance. The appearance of a snag depends particularly on (1) the degree of color contrast between the snag and the surrounding area of the fabric, or, (2) the presence of long distortions or long protrusions. These conditions are not evaluated when snagging is rated solely on the number of snags. See Section 3 for a description of terminology such as color contrast, distortion, and protrusion. See Figs. 1-3 for pictures of fabric defects due to snagging. Because the overall acceptability of a specific fabric is dependent on both the characteristics of the snags and other factors affecting fabric appearance, it is recommended that fabrics tested in the laboratory be evaluated with regard to the defects which may be visually observed and not rated solely on the number of snags developed. A series of visual rating standards (see 6.7) may be set up to provide a basis for the ratings. The visual rating standards are most advantageous when the tested laboratory specimens correlate closely in appearance with fabrics from a wear test; for example when tested laboratory specimens and fabrics from a wear test show similar color contrasts. In the preceding example, a series of fabrics from the wear test would be a good choice for the fabric standards described in 6.7.2. Also a point rating system may be used that considers the number of the snags and the appearance of the snags (see 13.3).

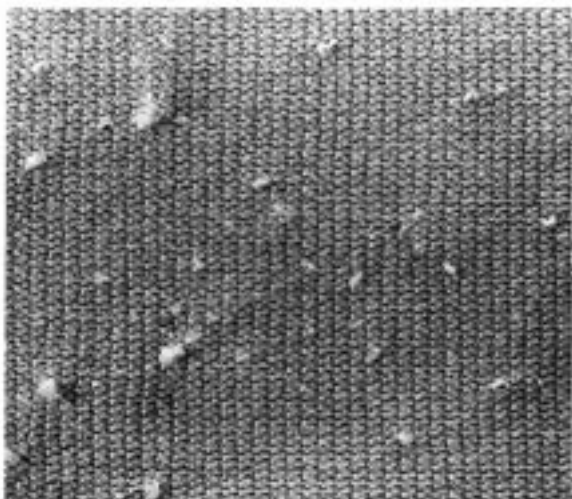

FIG. 1 A Snagged Specimen With Many Protrusion But No Distortions

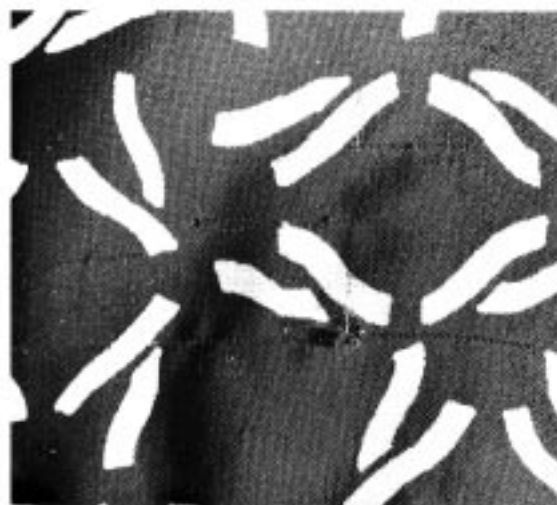

FIG. 3 A Snagged Specimen With Color Contrasts (Yarn Shifted from Dark Area to Light Area)

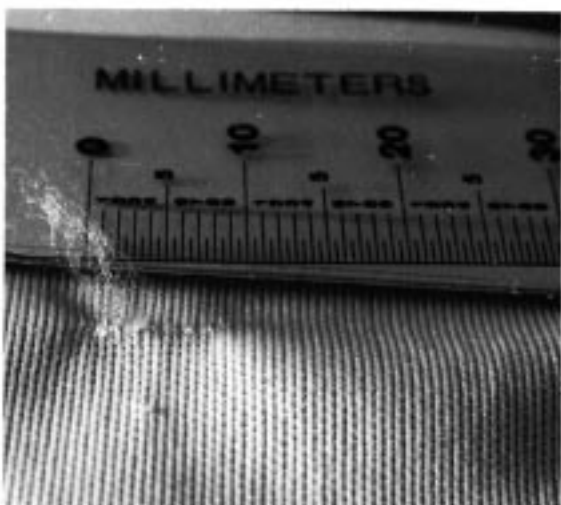

FIG. 2 A Snag That Includes Both a Protrusion and a Distortion



FIG. 4 The Bean Bag Snag Tester With Two Test Chambers

6. Apparatus and Materials

6.1 *Bean Bag Snag Tester*⁷, as shown in Fig. 4. Each rotating cylinder (2.1 ± 0.3 rad/s or 20 ± 3 r/min) is fitted with a snagging basket which is a removable framework of eight baffle bars attached at each end to plastic disks. Each baffle bar has a series of nine pins protruding from it. Each baffle bar is locked in the plastic disks so that when a baffle bar is exactly at the bottom of the cylinder, an angle of 0.5 ± 0.1 rad or $30 \pm 5^\circ$ exists between the pins on that baffle bar and a theoretical horizontal line passing through the end of the baffle bar.

⁷ The sole source of supply of the apparatus known to the committee at this time is (Atlas Electric Devices Co., 4114 N. Ravenswood Ave., Chicago, IL 60613). If you are aware of alternative suppliers, please provide this information to ASTM Headquarters. Your comments will receive careful consideration at a meeting of the responsible technical committee.

6.1.1 *Bean Bags*⁷, filled with shot and each weighing 450 ± 10 g or 1.0 ± 0.02 lb. A minimum of two bean bags is required, but six bean bags are suggested for efficiency.

6.2 *Specimen Template*, made of approximately 2 mm or 0.1 in. thick poster board, plastic or metal with dimensions of 215 mm by 115 mm or 8.5 in. by 4.5 in.

6.3 *Sewing Machine*, with a sewing needle that is appropriate for the fabric being tested for snagging resistance, or

6.4 *Sharps Hand Sewing Needle*.

6.5 *Sewing Thread*, cotton, Tex ticket 35 to 50, or equivalent polyester and cotton.

6.6 *Standard Calibration Fabric*, having an established snagging resistance rating that has been agreed upon by the purchaser and the supplier. (No standard calibration fabric has been specified by Subcommittee D13.59.)

6.7 *Visual Rating Standards* (for Option A):

6.7.1 *Photographic Standards*, a series of photographs of tested specimens that show the degrees of snagging, such as the

Imperial Chemical Industries (ICI) photographs,⁸ or

6.7.2 *Fabric Standards*, a series of tested specimens or fabrics from a wear test that show the degrees of snagging (see 5.6 and Note 2).

NOTE 2—Fabric standards should be stored and handled under conditions that will preserve their original form and appearance. Mount the fabric standards using white poster board, plastic or metal framing.

6.8 *Equipment for Fabric Evaluation for Option A*, for illumination and simultaneous viewing of specimens and visual rating standards:

6.8.1 *Apparatus for Fabric Evaluation:*

6.8.1.1 *Viewing Cabinet*⁹, (see Fig. 5) having a single cool white fluorescent tube with a correlated color temperature of 4100 to 4500 K.

⁸ The sole source of supply of the apparatus known to the committee at this time is (Shirley Developments Limited, P.O. Box 162, Crown Royal, Shawcross Street, Stockport, SK13JW, England; represented by Crosrol Inc., P.O. Box 6488, Greenville, SC 29606). If you are aware of alternative suppliers, please provide this information to ASTM Headquarters. Your comments will receive careful consideration at a meeting of the responsible technical committee.

⁹ The sole source of supply of the apparatus known to the committee at this time is Standard Scientific Supply Company, 601 West Market Street, Bethlehem, PA 18018-5208. If you are aware of alternative suppliers, please provide this information to ASTM Headquarters. Your comments will receive careful consideration at a meeting of the responsible technical committee.

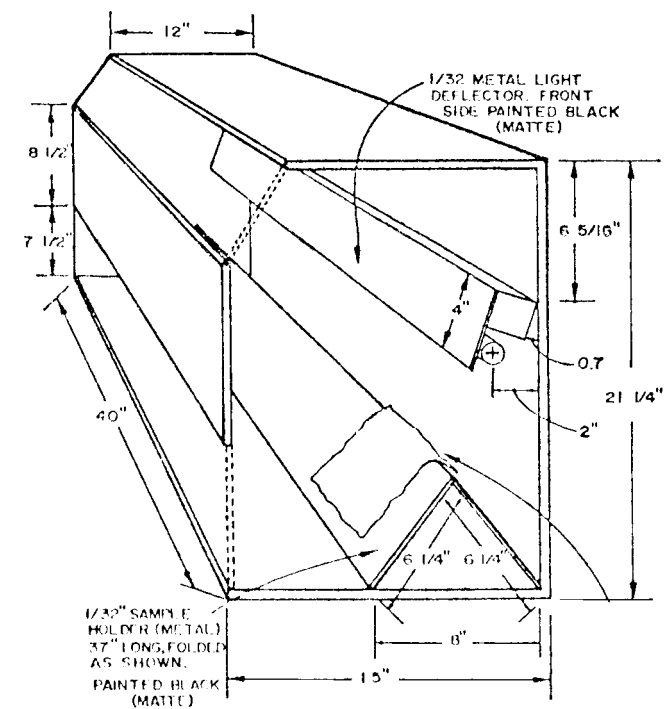

Metric Equivalents

in.	mm	in.	mm
1/32	1	8	203
0.7	18	8 1/2	215
2	50	12	305
4	100	15	380
6 1/4	159	21 1/4	540
6 9/16	160	37	940
7 1/2	190	40	1020

FIG. 5 Apparatus for Fabric Evaluation

6.8.1.2 *Specimen Viewing Mask (White)*, made of approximately 2 mm or 0.1 in. thick poster board, plastic or metal with outer dimensions of 100 mm by 100 mm or 4 in. by 4 in. and a center cutout of 75 mm by 75 mm or 3 in. by 3 in.

6.8.1.3 *Photographic Standard Viewing Mask (White)*, made of approximately 2 mm or 0.1 in. thick poster board, plastic or metal with outer dimensions of 130 mm by 95 mm or 5.2 in. by 3.8 in. and a center cutout of 75 mm by 75 mm or 3 in. by 3 in. The dimensions of this mask are for photographic standards (see 6.7.1) which have outer dimensions of 130 mm by 95 mm or 5.2 in. by 3.8 in. in size. Larger or smaller photographic standards will need a mask with corresponding outer dimensions. All photographic standard viewing masks must have the same center cutout viewing dimensions as the specimen viewing mask.

6.8.1.4 *Fabric Standard Viewing Mask (White)*, made of approximately 2 mm or 0.1 in. thick poster board, plastic or metal and with the outer dimensions the same as the dimensions of the fabric standard (see 6.7.2) and a center cutout of 75 mm by 75 mm or 3 in. by 3 in.

6.9 *Equipment for Fabric Evaluation for Option B*, for illumination and viewing of specimens:

6.9.1 *Desk Lamp*, having a single cool white fluorescent tube with a correlated color temperature of 4100 to 4500 K.

6.9.2 *Specimen Viewing Mask (White)*, made of approximately 2 mm or 0.1 in. thick poster board, plastic or metal with outer dimensions of 100 mm by 100 mm or 4 in. by 4 in. and a center cutout of 75 mm by 75 mm or 3 in. by 3 in.

6.10 *Optional Equipment:*

6.10.1 *Tumble Dryer*, as described in AATCC Test Method 135.

6.10.2 *Washing Machine*, as described in AATCC Test Method 135.

6.10.3 *Detergent*, heavy duty granule, the 1993 AATCC Standard Reference Detergent as described in AATCC Test Method 135. When agreed upon by the purchaser and the supplier a substitute detergent that does not include fabric softener or bleach may be used.

6.10.4 *Equivalent for Drycleaning Specimens*, as described in Test Methods D 2724.

7. Hazards

7.1 Locate the bean bag snag tester in a low-traffic area because of the danger from the exposed rotating cylinders.

7.2 Check that both the plastic disks and the ports are secure by making sure the front disks are flush with the front rims of the cylinders and by hand-tightening the screws that secure the ports.

7.3 Wear protective gloves when examining the pins or removing debris from the cylinders as described in 11.1.

7.4 Observe the following safety precautions when operating the tester: (1) do not wear loose or dangling clothing that can get caught in the pins or moving parts, (2) do not attempt to load or unload the chambers while the cylinders are rotating, and (3) do not injure your hands on the sharp pins when placing specimens in the chambers.

8. Sampling

8.1 *Lot Sample*—As a lot sample for acceptance testing,

take at random the number of rolls of fabric directed in an applicable material specification or other agreement between the purchaser and the supplier. Consider rolls of fabric to be the primary sampling units.

8.2 *Laboratory Sample*—As a laboratory sampling unit for acceptance testing, a full width swatch 1 m or 1 yd long from the end of each roll of fabric in the lot sample, after first discarding the outermost layer of fabric. When laundering and drycleaning tests are to be performed, take additional swatches for the laundering and drycleaning tests.

8.3 *Specimens*—Test three specimens from each swatch. When drycleaning and laundering tests are to be performed, test three additional specimens for drycleaning and three additional specimens for laundering.

9. Preparation of the Specimens

9.1 When snagging resistance after laundering or drycleaning is to be evaluated, launder or dryclean swatches as directed in 9.1.1 or 9.1.2 before cutting the specimens.

9.1.1 *Laundering*—Load the washer with a 3.5 kg or 8 lb total load of swatches that comprise a homogeneous load (for example, same manufacturer, same line, same finishing, and same previous care) or a homogeneous group of swatches for testing and a desized unsoftened group of ballast fabrics. Select normal cycle, warm water temperature, and the 1993 AATCC Standard Reference Detergent (see Terminology D 3136, and AATCC Test Method 135). Run one machine cycle and do not use softener. Load the dryer with the washed fabrics. Select normal cycle, medium temperature, and run the dryer for 20 min or until the fabrics are dry to the touch. Do not use softener in the dryer. Do not overdry the fabrics (see Note 3).

NOTE 3—When agreed upon by the purchaser and the supplier, other laundering and drycleaning procedures may be used.

9.1.2 *Drycleaning*—Follow the procedure in Test Methods D 2724 (see Note 3).

9.2 Using the specimen template (see 6.2), cut three specimens 215 mm by 115 mm or 8.5 in. by 4.5 in. with the lengthwise (machine) direction of the fabric parallel to the long dimension of the specimens (see Note 4). Do not take specimens nearer the selvage than one tenth the width of the fabric. If possible, randomize the specimens in a manner such that no two specimens contain the same set of yarns.

NOTE 4—A study² of the bean bag snag tester indicated that the random tumbling action does not result in a strong directional effect for the fabrics that were tested. Due to the absence of a strong directional effect, it is not necessary to test both lengthwise and widthwise specimens.

9.2.1 Similarly cut specimens from laundered or drycleaned swatches when required.

9.3 Fold each specimen in half by placing the two short ends together. After folding, the surface to be tested for snagging resistance is on the inside of the folded specimen, and the size of the folded specimen is 107 mm by 115 mm or 4.2 in. by 4.5 in.

9.4 Using a minimum of 0.4 stitches per millimetre or 10 stitches per inch, machine or hand sew a seam approximately 6.5 mm or 0.25 in. from the edge of each of the 107 mm or 4.2 in. sides of each of the folded specimens to form “socks.”

9.5 Turn each specimen inside out to expose the surface for testing.

10. Conditioning

10.1 Preconditioning is not necessary. Place all the specimens and bean bags (see 6.1.1) in the standard atmosphere for testing textiles, which is $21 \pm 1^\circ\text{C}$ ($70 \pm 2^\circ\text{F}$) and $65 \pm 2\%$ relative humidity (see Practice D 1776), for a minimum of 4 hours before testing. While this conditioning does not necessarily result in equilibrium moisture content in the specimens, it is deemed adequate for the purposes of this test method.

11. Calibration of the Apparatus

11.1 Open the port for each cylinder. Using protective gloves, and then pull the two snagging baskets (unit with pins) straight out of the cylinders by pulling on the inside rim of each plastic disk. Examine the pins for barbs, roughness and other damage, and replace any damaged parts. Remove any fibers, yarns, and other debris from the cylinders.

11.2 Reinsert the two snagging baskets inside the cylinders, align the hole in the rear of each plastic disk with the latching pin on the back wall of each cylinder, and make sure the front disks are flush with the front rims of the cylinders. Check the location of the snagging baskets periodically to be sure the front disks are flush with the front rims of the cylinders.

11.3 Check the operation of the snagging tester with a standard calibration fabric (see 6.6). Test three specimens of the standard calibration fabric using the procedures described in Sections 9-13. Run three more specimens if the overall average obtained on the standard calibration fabric is not within ± 0.5 rating units of the established snagging resistance rating. Continue testing if the overall average of this second set of specimens is within limits. Install new snagging baskets or new baffle bars with new pins if the second set of specimens is not within limits. Repeat checking the value of the standard calibration fabric until the overall average of a set of specimens is within the required limits.

11.4 Perform steps 11.1-11.3 after 200 specimens have been exposed to the snagging action in each cylinder.

12. Procedure

12.1 Test all specimens in the standard atmosphere for testing textiles, which is $21 \pm 1^\circ\text{C}$ ($70 \pm 2^\circ\text{F}$) and $65 \pm 2\%$ relative humidity.

12.2 Insert a bean bag into the specimen with the seamed end of the bean bag against the folded end of the specimen. Using a minimum of 0.4 stitches per millimetre or 10 stitches per inch, machine or hand sew a seam across the open end of the specimen 6.5 mm or 0.25 in. from the open end of the specimen. Trim the edge of the specimen so no more than 3 mm or 0.13 in. of fabric extends past this seam.

12.3 Inspect the specimen for the presence of any blemish such as accidental snags, pills, etc., which could affect the ratings for snagging resistance. If possible replace any blemished specimen with a new specimen. If it is not possible to replace the specimen (for example, the specimens pilled during laundering), record the fact and exclude the blemish when the specimen is evaluated for snagging resistance.

12.4 With the “operate” switch in the “off” position, open

the ports of the cylindrical test chambers and place one specimen in each chamber. Place the specimen in the bottom of the chamber with the visible seam at the top of the specimen (uppermost). Be careful not to accidentally snag the specimens or injure your hand.

12.5 Close the ports and tighten the screws that secure the ports.

12.6 Set the revolution counter to 100.

12.7 Place the operate switch to “on” and allow the machine to run until the buzzer sounds. Then place the operate switch to “off.”

12.8 Remove the specimens from the chambers being careful not to accidentally snag the specimens. Remove the thread from the visible seam of the specimen. If this is not possible, cut this seam off the specimen with scissors without damaging the bean bag. Cut the specimen within a distance of 3 mm or 0.13 in. of the seam. Remove the bean bag from the specimen.

12.9 Repeat steps 12.2-12.8 for the remaining untested specimens.

13. Evaluation

13.1 *General*—Choose Option A or Option B to evaluate the tested specimens (see Note 5).

NOTE 5—In Test Method D 5362 there may be no overall correlation between the results obtained with Option A and with Option B, because the options are based on different criteria. Option A is a modification of the mace test method evaluation system described in Test Method D 3939. Option B is a modification of the evaluation system described in a research study.³

13.2 *Option A*. Using suitable photographic snagging standards such as the ICI snagging standards (see Note 6)⁸, or using suitable fabric standards, rate the degree of snagging according to the following procedure.

NOTE 6—The ICI photographic snagging standards were developed for Test Method D 3939, but these standards can be used to evaluate the results of the bean bag test method. The standards consist of a set of 9 photoreplicas in which the intermediate rating is indicated as 3-4, 2-3, etc. In the ICI photographic snagging standards, the number of protrusions in each masked photoreplica are as follows: rating 5 has no protrusions, rating 4-5 has 5 protrusions, rating 4 has 10 protrusions, rating 3-4 has 15 protrusions, rating 3 has 25 protrusions, rating 2-3 has 45 protrusions, rating 2 has 60 protrusions, rating 1-2 has 80 protrusions, and rating 1 has 110 protrusions. Because the ICI standards differ only in the number of protrusions, it is recommended that appearance changes such as color contrasts also be reported (see 13.2.6).

13.2.1 Place a specimen on the sample holder of the apparatus for fabric evaluation (see Fig. 5) with the folded edge of the specimen touching the base (the base is the board touching the table) of the apparatus. Holding the top portion of the specimen against the sample holder to keep the specimen from slipping down, place the specimen viewing mask (see 6.8.1.2) so it also touches the base of the apparatus. Align the sides of the specimen and the sides of the mask so they are parallel and align the center of the specimen so it is in the center of the mask. If either the specimen or the mask slip, place a flat object such as a ruler on the base to keep both the specimen and mask flat against the sample holder (see Note 7). Straighten the specimen so there are no wrinkles (a piece of poster board, plastic or metal can be inserted inside the specimen to reduce the number of wrinkles). Hold the speci-

men viewing mask against the specimen to minimize the shadow cast by the mask with respect to its angle to the light source. Place the photographic standard or the fabric standard that matches the degree of snagging observed on the specimen next to the specimen and place the photographic standard viewing mask over the photographic standard, or place the fabric standard viewing mask over the fabric standard (see Note 7).

NOTE 7—The purpose of the specimen mask is to cover the areas of the specimen near the two side seams and the folded edge so a flat area of 75 mm by 75 mm or 3 in. by 3 in. can be viewed. The purpose of the photographic standard viewing mask and the fabric standard viewing mask is to show a flat area which is the same size as the area shown by the specimen mask.

13.2.2 After turning the light on in the apparatus for fabric evaluation (see Fig. 5), rate the area of one side of the specimen using the following scale (see Note 8).

5	no or insignificant snagging
4	slight snagging
3	moderate snagging
2	severe snagging
1	very severe snagging

For rating number 5, insignificant snagging means a few snags are present (approximately 1 to 4 snags are present). The ICI snagging standards have photographs showing intermediate values (see Note 6). For standards that do not have intermediate values, an intermediate value can be assigned when the appearance of a specimen falls roughly equidistant between that of two whole number rating standards.

NOTE 8—Fabric standards assembled from tested specimens or a wear test, representing the level of snagging equivalent to each of the five rating steps, are valuable as a reference to ensure uniformity in rating. Individual laboratories can have available fabric rating standards for each type of fabric of particular interest. When rating the specimens, the rater’s eyes must be approximately 300 mm or 12 in. from the fabric surface. This is the rating distance used in the apparatus for fabric evaluation and the point system in Option B.

13.2.3 Turn the specimen over, place the specimen and specimen viewing mask on the sample holder as directed in 13.2.1, and rate the area of the specimen within the center of the mask as directed in 13.2.2. To the nearest 0.5 scale unit, average the two ratings to obtain an average rating for the specimen.

13.2.4 Repeat steps 13.2.1-13.2.3 for the remaining specimens.

13.2.5 For each laboratory sampling unit, calculate the average rating by averaging the observations from the three specimens to the nearest 0.5 scale unit.

13.2.6 For each laboratory sampling unit, examine the specimens to determine if color contrasts, long distortions (longer than 15 mm or 0.6 in.) or long protrusions (longer than 4 mm or 0.15 in.) are present. If at least two of the three specimens have color contrasts, long distortions, or long protrusions, then these attributes should be reported (see 14.2.6). For standards that differ only in the number of protrusions (see Note 6), also report the presence of short distortions (shorter than or equal to 15 mm or 0.6 in.) if short distortions were found on at least two of the three specimens.

13.3 *Option B.* Using a point system, determine the snagging resistance of the laboratory sampling unit.

13.3.1 Sit at a table with a fluorescent desk lamp (see 6.9.1) directly in front of your chest. Place a specimen flat on the table with (1) the folded edge of the specimen nearest your chest, (2) the center of the specimen approximately 300 mm or 12 in. from your eyes, and (3) an angle of viewing of 0 ± 0.8 rad or 0 ± 45 degrees (this is the angle between the imaginary line from your eyes to the center of the specimen and another imaginary line which originates in the center of the specimen and is perpendicular to the surface of the table). Place the specimen viewing mask on top of one side of the specimen so (1) an outer edge of the mask is even with and parallel to the folded edge of the specimen, (2) the sides of the specimen are parallel to the sides of the mask, and (3) the center of the specimen is in the center of the mask (see Note 7). Straighten the specimen to remove any wrinkles (a piece of poster board, plastic or metal can be inserted inside the specimen to reduce the number of wrinkles).

13.3.2 Turn on the light and total the number of points from the visible area of the specimen using the following point system.

13.3.2.1 To a snag with a protrusion and no distortion assign 1 point.

13.3.2.2 To a snag with both a protrusion and a distortion assign 3 points.

13.3.2.3 To a snag with a distortion and no protrusion assign 3 points.

13.3.2.4 Refer to Section 3 and Figs. 1-3 for information about protrusions and distortions. To be counted, both protrusions and distortions should be prominent; in other words if you have to pause and stare at the snag to see it, then the difficult to see protrusion, distortion, or both should not be counted. Any protrusion that originates from under the specimen viewing mask (the base of the protrusion is under the mask) should not be counted in the point system; however, a distortion that originates from under the mask and extends into the rating area should be counted because it is a defect in the rating area.

13.3.3 Turn the specimen over, place the specimen viewing mask on the specimen as directed in 13.3.1, and total the number of points on this side as directed in 13.3.2.

13.3.4 Combine the points from both sides of the specimen. Using the following table, assign a rating based on the total points from both sides. This option does not use intermediate values.

Rating	Total Points (Both Sides)	Interpretation
5	0 to 2	no or insignificant snagging
4	3 to 10	slight snagging
3	11 to 19	moderate snagging
2	20 to 39	severe snagging
1	40 or more	very severe snagging

13.3.5 Repeat steps 13.3.1-13.3.4 for the other specimens.

13.3.6 For each laboratory sampling unit, calculate the average rating by averaging the observations from the three specimens to the nearest 1.0 scale unit.

13.3.7 For each laboratory sampling unit, examine the six specimens to determine if color contrasts, long distortions

(longer than 15 mm or 0.6 in.), or long protrusions (longer than 4 mm or 0.15 in.) are present. If at least two of the three specimens have color contrasts, long distortions, or long protrusions then these attributes should be reported (see 14.2.6).

14. Report

14.1 State that the specimens were tested as directed in Test Method D 5362. Describe the material and the method of sampling used.

14.2 *Report the following information:*

14.2.1 The method of preparation of the specimens including the use of laundering or drycleaning.

14.2.2 The number of cylinder revolutions used to test each specimen.

14.2.3 The Option or other technique used for the evaluation.

14.2.4 The type of visual rating standards used if Option A was selected.

14.2.5 The point system if Option B was selected.

14.2.6 For each laboratory sampling unit, the average rating and any appearance changes (see 13.2.6 and 13.3.7) in the specimens.

14.2.7 If laundering tests were conducted, repeat 14.2.2-14.2.6 for the laundered specimens.

14.2.8 If drycleaning tests were conducted, repeat 14.2.2-14.2.6 for the drycleaned specimens.

15. Precision and Bias

15.1 *Precision*¹⁰—An interlaboratory study of Test Method D 5362 was conducted by the D13.59 task group on fabric snagging. Because the results from this test method are expressed as rating steps or grades, the data fit a non-normal distribution and Practice D 4467 was used to design and evaluate the interlaboratory study. The interlaboratory study had randomly drawn samples of two materials tested in each of four laboratories. Each laboratory had one operator who tested three specimens of each material. Material A was a woven fabric and Material B was a knit fabric.

15.1.1 The results of the interlaboratory study are shown in Table 1. The evaluation technique was Option B which is described in Section 13.3. Using the Friedman Rank-Sum Test¹¹ with corrections for excessive number of ties, the Friedman Rank-Sum Statistic for the difference between laboratories was 3.0: This statistic is not significant at the 5 % level

¹⁰ Supporting data are available from ASTM Headquarters. Request RR: D13-1098.

¹¹ Siegel, S. and Castellan, N. J. Nonparametric Statistics for the Behavioral Sciences, McGraw-Hill Book Company, 1998, pp. 178-180.

TABLE 1 Interlaboratory Test of the Bean Bag Test Method

Laboratory	Material		
	A	B	Average
I	4.0	3.0	3.5
II	4.0	3.0	3.5
III	4.0	3.0	3.5
IV	3.0	3.0	3.0
Average	3.8	3.0	



D 5362

of significance; thus, the difference between laboratories is not significant.

15.2 *Bias*—The procedure in this test method has no bias because the value of the property can be defined only in terms of a test method.

16. Keywords

16.1 knitted textile fabrics; snagging resistance; woven textile fabric

The American Society for Testing and Materials takes no position respecting the validity of any patent rights asserted in connection with any item mentioned in this standard. Users of this standard are expressly advised that determination of the validity of any such patent rights, and the risk of infringement of such rights, are entirely their own responsibility.

This standard is subject to revision at any time by the responsible technical committee and must be reviewed every five years and if not revised, either reapproved or withdrawn. Your comments are invited either for revision of this standard or for additional standards and should be addressed to ASTM Headquarters. Your comments will receive careful consideration at a meeting of the responsible technical committee, which you may attend. If you feel that your comments have not received a fair hearing you should make your views known to the ASTM Committee on Standards, at the address shown below.

This standard is copyrighted by ASTM, 100 Barr Harbor Drive, PO Box C700, West Conshohocken, PA 19428-2959, United States. Individual reprints (single or multiple copies) of this standard may be obtained by contacting ASTM at the above address or at 610-832-9585 (phone), 610-832-9555 (fax), or service@astm.org (e-mail); or through the ASTM website (www.astm.org).