

This document is not an ASTM standard and is intended only to provide the user of an ASTM standard an indication of what changes have been made to the previous version. Because it may not be technically possible to adequately depict all changes accurately, ASTM recommends that users consult prior editions as appropriate. In all cases only the current version of the standard as published by ASTM is to be considered the official document.



Designation: D 5587 – 96 (Reapproved 2003)



Designation: D 5587 – 03

Standard Test Method for Tearing Strength of Fabrics by Trapezoid Procedure¹

This standard is issued under the fixed designation D 5587; the number immediately following the designation indicates the year of original adoption or, in the case of revision, the year of last revision. A number in parentheses indicates the year of last reapproval. A superscript epsilon (ε) indicates an editorial change since the last revision or reapproval.

¹ This test method is under the jurisdiction of ASTM Committee D13 on Textiles and is the direct responsibility of Subcommittee D13.60 on Fabric Test Methods, Specific. Current edition approved Feb. 10, 1996; Oct. 1, 2003. Published April October 2003. Originally approved in 1996. Last previous edition approved in 1996 as D 5587 – 96.

1. Scope

1.1 This test method covers the measurement of the tearing strength of textile fabrics by the trapezoid procedure using a recording constant-rate-of-extension-type (CRE) tensile testing machine.

1.1.1 The CRE-type tensile testing machine has become the preferred test apparatus for determining trapezoid tearing strength. It is recognized that some constant-rate-of-traverse-type (CRT) tensile testing machines continue to be used. Consequently, these test instruments may be used when agreed upon between the purchaser and the supplier. The conditions for use of the CRT-type tensile tester are included in Appendix X1.

1.2 This test method applies to most fabrics including woven fabrics, air bag fabrics, blankets, napped fabrics, knitted fabrics, layered fabrics, and pile fabrics. The fabrics may be untreated, heavily sized, coated, resin-treated, or otherwise treated. Instructions are provided for testing specimens with or without wetting.

1.3 Tearing strength, as measured in this test method, requires that the tear be initiated before testing. The reported value obtained is not directly related to the force required to initiate or start a tear.

1.4 Two calculations for trapezoid tearing strength are provided: the single-peak force and the average of five highest peak forces.

1.5 The values stated in SI units are to be regarded as the standard. The values stated in inch-pound units may be approximate.

1.6 *This standard does not purport to address all of the safety concerns, if any, associated with its use. It is the responsibility of the user of this standard to establish appropriate safety and health practices and determine the applicability of regulatory limitations prior to use.*

2. Referenced Documents

2.1 ASTM Standards:²

D 76 Specification for Tensile Testing Machines for Textiles

D 123 Terminology Relating to Textiles

D 629 Test Methods for Quantitative Analysis of Textiles

D 1776 Practice for Conditioning Textiles for and Testing Textiles

D 2904 Practice for Interlaboratory Testing of a Textile Test Method That Produces Normally Distributed Data

D 2906 Practice for Statements on Precision and Bias for Textiles

~~D 4848 Terminology of Force, Deformation and Related Properties of Textiles~~³ D 4850 Terminology Relating to Fabric

2.2 ASTM Adjuncts:

² For referenced ASTM standards, visit the ASTM website, www.astm.org, or contact ASTM Customer Service at service@astm.org. For *Annual Book of ASTM Standards* volume information, refer to the standard's Document Summary page on the ASTM website.

TEX-PAC³

3. Terminology

3.1 Definitions—For

3.1 For definitions of other textile terms used in this test method, refer to Terminology D 123. For definitions of other terms related to force and deformation fabric, in textiles, refer to Terminology D 4848.

3.2 Definitions of Terms Specific to This Standard:

3.2.1 *cross-machine direction, CD, n*—the direction in the plane of the fabric perpendicular to the direction of manufacture.

3.2.1.1 *Discussion*—This term is used to refer to the direction analogous to coursewise or filling direction in knitted or woven fabrics, respectively.

3.2.2 *fabric, in textiles, n*—a planar structure consisting of yarns or fibers.

3.2.3 *machine direction, MD, n*—the direction in the plane of the fabric parallel to the direction of manufacture.

3.2.3.1 *Discussion*—This term is used to refer to the direction analogous to walewise or warp direction in knitted or woven fabrics, respectively.

3.2.4 *peak textiles; peak force, in tear testing of fabrics, n*—the maximum force required to break one or more yarn components in a woven or knitted fabric specimen, or break the fiber, the fiber bonds, or fiber interlocks in other manufactured fabric forms.

3.2.4.1 *Discussion*—The peak force may consist of a single peak or a series of peaks depending upon the nature of the fabric. Typically for woven fabrics, if a small decrease in force occurs at a time when the force is increasing, it is not considered to peak unless the indicated force exceeds the force required to break a yarn. Lower shifts corresponding to yarn movement do not qualify as peaks since no yarns are broken.

3.2.5 *tearing fabrics; tearing force, in fabric, n*—the force required to propagate a tear initiated under specified conditions.

3.2.5.1 *Discussion*—The trapezoid fabric; tearing force may be calculated from a single peak or a multiple-peak force-extension curve.

3.2.6 *tearing strength, in fabrics, n*—the capacity of a fabric fabrics, refer to withstand the tearing force required Terminology D 4850.

3.2 For other textile terms used in this test method, refer to propagate a tear after its initiation. Terminology D 123.

4. Summary of Test Method

4.1 An outline of an isosceles trapezoid is marked on a rectangular specimen (see Fig. 1). The specimen is slit at the center of the smallest base of the trapezoid to start the tear. The nonparallel sides of the marked trapezoid are clamped in parallel jaws of a tensile testing machine. The separation of the jaws is increased continuously to apply a force to propagate the tear across the specimen. At the same time, the force developed is recorded. The force to continue the tear is calculated from autographic chart recorders or microprocessor data collection systems.

5. Significance and Use

5.1 This test method is considered satisfactory for acceptance testing of commercial shipments since because current estimates of between-laboratory precision are acceptable, and this test method is used extensively in the trade for acceptance testing.

5.1.1 In case of a dispute arising from

5.2 If there are differences in reported of practical significance between test results when using this test method for acceptance testing of commercial shipments, the purchaser and the supplier should conduct two laboratories (or more), comparative test should be performed to determine if there is a statistical bias between their laboratories. Competent them, using competent statistical assistance is recommended for the investigation of bias. assistance. As a minimum, use the two parties should take samples for such a group of comparative test specimens that are as homogeneous as possible and that are possible, drawn from the same lot of material of as the type samples that resulted in question. Test specimens then should be randomly assigned disparate results during initial testing. Randomly assign the samples in equal numbers to each laboratory for testing. laboratory. The average test results from the two laboratories involved should be compared using the appropriate a statistical analysis and an acceptable test for unpaired data, a probability level chosen by prior to the two parties before testing is begun. series. If a bias is found, either its cause must be found and corrected, or the purchaser and the supplier must agree to interpret future test results with for that material must be adjusted in consideration to of the known bias.

5.23 The trapezoid tear produces tension along a reasonably defined course such that the tear propagates across the width of the specimen. It is useful for estimating the relative tear resistance of different fabrics or different directions in the same fabric.

5.34 Depending on the nature of the specimen, the data recording devices will show the tearing force in the form of a peak or peaks. The highest peaks appear to reflect the strength of the yarn components, individually or in combination, needed to stop a tear in fabrics of the same construction. The valleys recorded between the peaks have no specific significance. The minimum tearing force, however, is indicated to be above the lowest valleys.

Annual Book of ASTM Standards, Vol 07.01.

³ The PC programs on floppy disks for analyzing Committee D-13 interlaboratory data are available from ASTM. For a 3½-in. disk, request PCN:12-429040-18, and for a 5¼-in. disk, request PCN:12-429041-18.

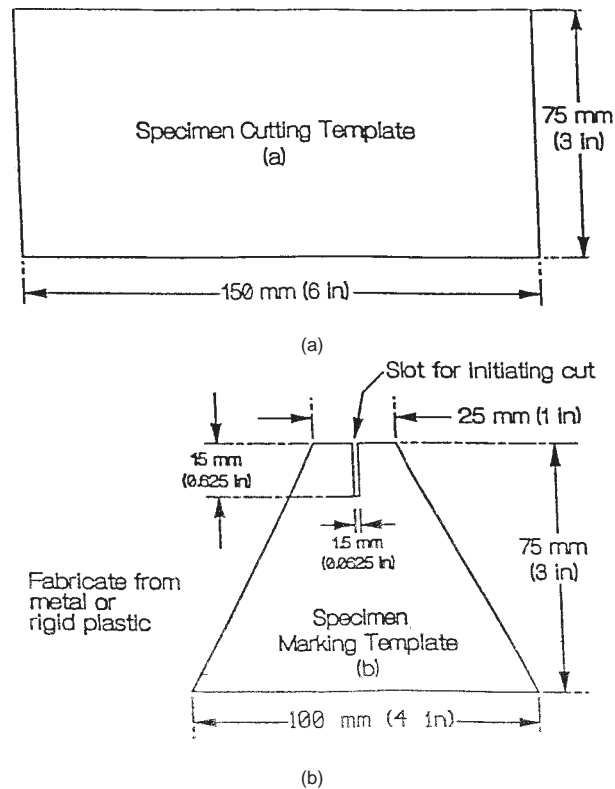

FIG. 1 Templates for Cutting and Marking Trapezoid Test Specimens

5.45 Most textile fabrics can be tested by this test method. Some modification of clamping techniques may be necessary for a given fabric, depending upon its structure. Strong fabrics or fabrics made from glass fibers require special adaptation to prevent them from slipping in the clamps or being damaged as a result of being gripped in the clamps.

5.56 The CRE-type is the preferred tensile testing machine. This test method allows the use of the CRT-type tensile machine when agreed upon between the purchaser and the supplier. There may be no overall correlation, however, between the results obtained with the CRT-type machine and the CRE-type machine. Consequently, these two tensile testers cannot be used interchangeably unless the degree of quantitative correlation has been established between the purchaser and the supplier. In any event, the CRE-type machine shall prevail.

6. Apparatus

6.1 *Tensile Testing Machine*, of the CRE-type conforming to the requirements of Specification D 76 with autographic recorder, or automatic microprocessor data gathering system.

6.2 *Clamps*, having all gripping surfaces parallel, flat, and capable of preventing slipping of the specimen during a test, and measuring at least 50 by 75 mm (at least 2 by 3 in.), with the longer dimension perpendicular to the direction of application of the force.

6.2.1 The use of hydraulic pneumatic clamping systems with a minimum of 50 by 75-mm (2 by 3-in.) serrated or rubber jaw faces having a clamping force at the grip faces of 13 to 14 kN (2900 to 3111 lbf) is recommended. Manual clamping is permitted providing no slippage of the specimen is observed.

6.2.2 For some fabrics, to prevent slippage when using jaw faces other than serrated, such as rubber-faced jaws, the jaw faces may be covered with a No. 80 to 120 medium-grit emery cloth. Secure the emery cloth to the jaw faces with pressure-sensitive tape.

6.3 *Cutting Die or Template*, having essentially the shape and dimensions shown in Fig. 1a.

6.4 *Trapezoid-Shaped Template*, having dimensions as shown in Fig. 1b.

7. Sampling and Test Specimens

7.1 *Lot Sample*—As a lot sample for acceptance testing, randomly select the number of rolls or pieces of fabric directed in an applicable material specification or other agreement between the purchaser and the supplier. Consider the rolls or pieces of fabric to be the primary sampling units. In the absence of such an agreement, take the number of fabric rolls specified in Table 1.

NOTE 1—An adequate specification or other agreement between the purchaser and the supplier requires taking into account the variability between rolls or pieces of fabric and between specimens from a swatch from a roll or piece of fabric to provide a sampling plan with a meaningful producer's risk,

TABLE 1 Number of Rolls or Pieces of Fabric in the Lot Sample

Number of Rolls or Pieces in Lot, Inclusive	Number of Rolls or Pieces in Lot Sample
1 to 3	all
4 to 24	4
25 to 50	5
over 50	10 % to a maximum of 10 rolls or pieces

consumer’s risk, acceptable quality level, and limiting quality level.

7.2 Laboratory Sample—For acceptance testing, take a swatch extending the width of the fabric and approximately 1 m (1 yd) along the machine direction from each roll or piece in the lot sample. For rolls of fabric, take a sample that will exclude fabric from the outer wrap of the roll or the inner wrap around the core of the roll of fabric.

7.3 Test Specimens—From each laboratory sampling unit, take five specimens from the machine direction and five specimens from the cross-machine direction, for each test condition described in 9.1 and 9.2, as applicable to a material specification or contract order.

7.3.1 Direction of Test—Consider the long direction as the direction of test.

7.3.2 Cutting Test Specimens—Take the specimens to be used for the measurement of machine direction with the longer dimension parallel to the machine direction. Take the specimens to be used for the measurement of the cross-machine direction with the longer dimension parallel to the cross-machine direction. When specimens are to be tested wet, take the specimens from areas adjacent to the dry test specimens. Label to maintain specimen identity.

7.3.2.1 In cutting the woven fabric specimens, take care to align the yarns running in the short direction parallel with the die such that when the slit is cut, the subsequent tear will take place between these yarns and not across them. This precaution is most important when testing bowed fabrics.

7.3.2.2 Cut specimens representing a broad distribution across the width and length, preferably along the diagonal of the laboratory sample, and no nearer the edge than one tenth its width. Ensure specimens are free of folds, creases, or wrinkles. Avoid getting oil, water, grease, and so forth, on the specimens when handling.

7.3.2.3 Use the cutting die or template described in 6.3 and shown in Fig. 1. Mark each specimen with an isosceles trapezoid template (see Figs. 1 and 2). Make a preliminary cut 15 mm (0.625 in.) long at the center of the 25-mm (1-in.) edge, as shown in Figs. 1 and 2.

8. Preparation of Test Apparatus and Calibration

8.1 Set the distance between the clamps at the start of the test at 25 ± 1 mm (1 ± 0.05 in.).

8.2 Select the full-scale force range of the testing machine such that the maximum force occurs between 15 and 85 % of full-scale force.

8.3 Set the testing speed to 300 ± 10 mm (12 ± 0.5 in./min).

8.4 Verify calibration of the tensile testing machine as specified in the manufacturer’s instructions and Specification D 76.

8.5 When using microprocessor automatic data gathering systems, set the appropriate parameters as specified in the manufacturer’s instructions.

9. Conditioning

9.1 *Condition 1, for Standard Testing :*

9.1.1 Precondition the specimens by bringing them to approximate moisture equilibrium in the standard atmosphere for preconditioning textiles as specified in Practice D 1776, unless otherwise specified in a material specification or contract order.

9.1.2 After preconditioning, bring the test specimens to moisture equilibrium for testing in the standard atmosphere for testing textiles as specified in Practice D 1776 or, if applicable, in the specified atmosphere in which the testing is to be performed, unless otherwise directed in a material specification or contract order.

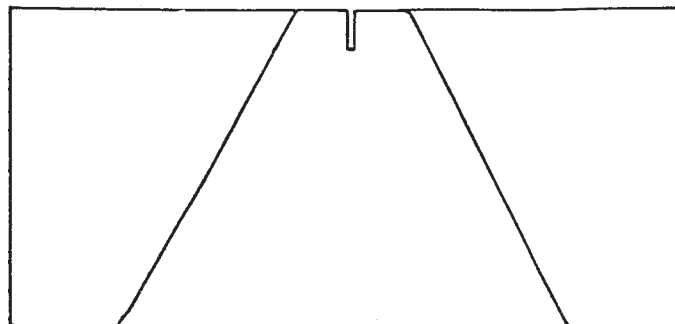

FIG. 2 Diagram of Marked Trapezoid Specimen

9.2 Condition 2, for Wet Specimen Testing:

9.2.1 When desizing treatments are specified prior to wet testing, use desizing treatments that will not affect the normal physical property of the fabric as specified in Test Method D 629.

9.2.2 Submerge the specimens in a container of distilled or deionized water at ambient temperature until thoroughly soaked (see section 8.2.1.1).

9.2.2.1 The time of immersion must be sufficient to wet out the specimens, as indicated by no significant change in tearing force followed by longer periods of immersion. For most fabrics this time period will be about 1 h. For fabrics not readily wet out with water, such as those treated with water-repellent or water-resistant materials, add a 0.1 % solution of a nonionic wetting agent to the water bath.

10. Procedure

10.1 Test the conditioned specimens in the standard atmosphere for testing textiles, which is $21 \pm 1^\circ\text{C}$ ($70 \pm 2^\circ\text{F}$) and $65 \pm 2\%$ relative humidity, unless otherwise specified in a material specification or contract order.

10.2 Secure the test specimen in the machine, clamping along the nonparallel sides of the trapezoid such that the end edges of the clamps are in line with the 25-mm (1-in.) long side of the trapezoid, and the cut is halfway between the clamps. Hold the short edge taut, and let the remaining fabric lie in folds.

10.2.1 For wet testing, remove a specimen from the water, and immediately mount it on the testing machine in the normal setup. Perform the test within 2 min after removal of the specimen from the water. If more than 2 min elapse between taking the wet specimen from the water bath and starting the tension testing machine, discard the specimen and take another.

10.3 Start the machine and record the tearing force on the recording device. The tearing force may increase to a simple maximum value or may show several maxima and minima, as shown in Fig. 3.

10.4 After the crosshead has moved to produce approximately 6 mm (0.25 in.) of fabric tear, record the single-peak force or multiple-peak forces as indicated for the type fabric and tearing action observed. Stop the crosshead motion after a total tear of approximately 75 mm (3 in.) or the fabric has torn completely, and return the crosshead to its starting position.

10.4.1 If a fabric slips in the jaws or if 25 % or more of the specimens break at a point within 5 mm (0.25 in.) of the edge of the jaw, then the jaws may be padded, the fabric may be coated under the jaw face area, or the jaw face may be modified. If any of these modifications are used, state the method of modification in the report.

10.4.2 If 25 % or more of the specimens break at a point within 5 mm (0.25 in.) of the edge of the jaw after making the modifications described in 10.4.1, consider the fabric untearable by this test method.

10.4.3 Record if the tear occurs crosswise to the direction of applied force.

10.5 Remove the tested specimen and continue as directed in 10.2-10.5 until five specimens have been tested for each principal direction from each laboratory sampling unit.

11. Calculation

11.1 *Tearing Force, Individual Specimens*—Calculate the trapezoid tearing force for individual specimens to the nearest 0.1 mN (0.1 lbf) using readings directly from the data collection system or autographic recorder using Option 1 or 2 as indicated by the tearing action of the material, unless otherwise agreed upon between the purchaser and the supplier.

11.1.1 *Option 1, Average of Five Highest Peaks:*

11.1.1.1 For fabrics exhibiting five peaks or more, after the first 6 mm (0.25 in.) of tear, determine the five highest peak forces to the nearest 0.1 mN (0.1 lbf).

11.1.1.2 Calculate the average of these five highest peak forces.

11.1.2 *Option 2, Single-Peak Force*—For fabrics exhibiting less than five peaks, record the highest peak force as the single-peak force to the nearest 0.1 mN (0.1 lbf).

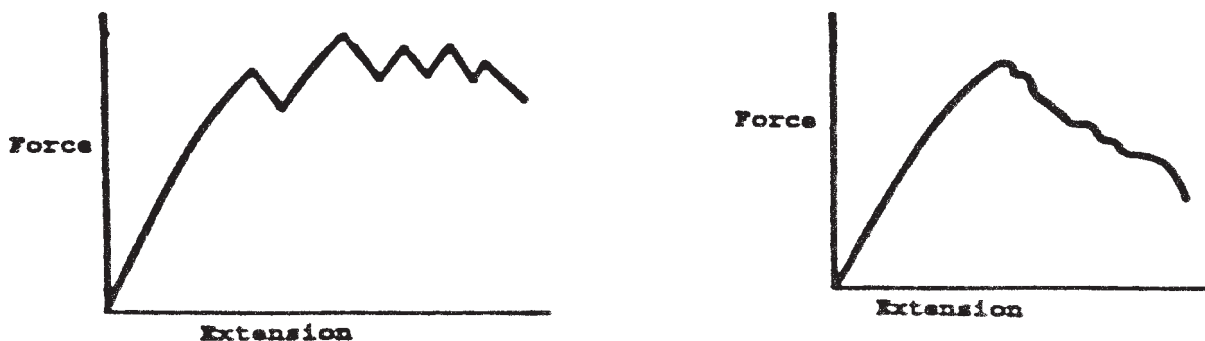

(a) Fabric Exhibiting Several Maxima

(b) Fabric Exhibiting Single Maxima

FIG. 3 Typical Trapezoid Tearing Force-Extension Curves for Individual Specimens

11.2 *Tearing Strength*—Calculate the trapezoid tearing strength as the average tearing force for each testing direction and condition for each laboratory sampling unit and for the lot for each principal direction.

11.3 *Standard Deviation, Coefficient of Variation* —Calculate when requested.

11.4 *Computer-Processed Data*—When data are automatically computer-processed, calculations are generally contained in the associated software. Record values as read from the direct-reading scale to the nearest 0.1 mN (0.1 lbf). In any event, it is recommended that computer-processed data be verified against known property values and its software described in the report.

12. Report

12.1 Report that the trapezoid tearing strength was determined in accordance with Test Method D 5587. Describe the fabric or product sampled and the method of sampling used.

12.2 Report the following information for each laboratory sampling unit and for the lot as applicable to a material specification or contract order:

12.2.1 Trapezoid tearing strength for each testing direction and condition.

12.2.2 Calculation option used, either single-peak force or average of five highest peak forces.

12.2.3 Condition of the specimens (without wetting or wet).

12.2.4 When calculated, the standard deviation or the coefficient of variation.

12.2.5 For computer-processed data, identify the program (software) used.

12.2.6 Make, model, and capacity of testing machine.

12.2.7 Type of clamps used.

12.2.8 Any modification of this test method.

13. Precision and Bias

13.1 *Summary*—In comparing two averages, the differences should not exceed the single-operator precision values shown in Table 2 for the respective number of tests and for materials having averages similar to those shown in Table 3 in 95 out of 100 cases when all the observations are taken by the same well-trained operator using the same piece of equipment and specimens randomly drawn from the sample of fabric. Larger differences are likely to occur under all other circumstances.

13.2 *Interlaboratory Test Data*—An interlaboratory test was run in 1994 through 1995 in which randomly drawn samples of three fabrics were tested in each of five laboratories. Two operators in each laboratory each tested eight specimens of each fabric using this test method. Four of the eight specimens were tested on one day and four specimens were tested on a second day. Analysis of the data was conducted using Practices D 2904 and D 2906, as well as the adjunct Tex-Pac. The components of variance for trapezoid tear strength expressed as standard deviations were calculated to be the values listed in Table 3. The three woven fabric types were:

Material 3—S/1008H, Plain Weave Sheeting, With Spun Yarns
 Material 7—S/28305, Plain Weave, Continuous Filament Yarns
 Material 13—S/9408R, Twill Weave

13.3 *Precision*—For the components of variance reported in Table 3, two averages of observed values should be considered significantly different at the 95 % probability level if the difference equals or exceeds the critical differences listed in Table 2. There were sufficient differences related to the fabric type and structure to warrant listing the components of variance and the critical differences separately. Consequently, no multi-fabric comparisons were made.

NOTE 2—The tabulated values of the critical differences should be considered to be a general statement, particularly with respect to between-laboratory precision. Before a meaningful statement can be made about two specific laboratories, the amount of statistical bias, if any, between them must be established with each comparison being based on recent data obtained on specimens taken from a lot of fabric to the type being evaluated, so as to be as nearly homogeneous as possible, and then randomly assigned in equal numbers to each of the laboratories.

TABLE 2 Trapezoid Tear Strength, lb, Critical Differences for the Conditions Noted^A

Materials	Number of Observations in Each Average	Single-Operator Precision	Within-Laboratory Precision	Between-Laboratory Precision
S/1008H	1	7.27	7.27	7.27
	2	5.14	5.14	5.14
	5	3.25	3.25	3.25
	10	2.30	2.30	2.30
S/28305	1	27.5	27.5	43.9
	2	19.5	19.5	39.3
	5	12.3	12.3	35.2
	10	8.7	8.7	34.9
S/9408R	1	7.9	7.9	12.2
	2	5.6	5.6	10.9
	5	3.5	3.5	10.0
	10	2.5	2.5	9.7

^AThe critical differences were calculated using $t = 1.960$, which is based on infinite degrees of freedom.

TABLE 3 Trapezoid Tear Strength, lb

Materials	Grand Average	Components of Variance Expressed as Standard Deviations ^A		
		Single-Operator Component	Within-Laboratory Component	Between-Laboratory Component
Woven Fabrics				
S/1008H	14.3	2.6	0.0	0.0
S/28305	101.9	9.9	0.0	12.3
S/9408R	34.4	2.8	0.0	3.4

^AThe square roots of the components of variance are being reported to express the variability in the appropriate units of measure rather than as the squares of those units of measure.

13.4 *Bias*—The value of trapezoid tear strength can only be defined in terms of a test method. Within this limitation, this test method has no known bias.

14. Keywords

14.1 fabric; tearing strength; trapezoid

APPENDIX

(Nonmandatory Information)

X1. CONDITIONS WHEN USING CRT-TYPE TENSILE TESTERS

X1.1 General

X1.1.1 The following information is provided for determining trapezoid tearing strength using the CRT-type tensile tester with this test method. See 1.1.1.

X1.1.2 *Tensile Testing Machine*, of the constant-rate-of-traverse (CRT) pendulum type conforming to the requirements of Specification D 76 with autographic recorder or automatic microprocessor data gathering systems.

X1.1.3 Set the testing speed to 300 ± 10 mm/min (12 ± 0.5 in./min). Disengage the pawls from the ratchet to render them inoperative.

X1.1.4 Report that the trapezoid tearing test was determined using a CRT-type tensile tester.

ASTM International takes no position respecting the validity of any patent rights asserted in connection with any item mentioned in this standard. Users of this standard are expressly advised that determination of the validity of any such patent rights, and the risk of infringement of such rights, are entirely their own responsibility.

This standard is subject to revision at any time by the responsible technical committee and must be reviewed every five years and if not revised, either reapproved or withdrawn. Your comments are invited either for revision of this standard or for additional standards and should be addressed to ASTM International Headquarters. Your comments will receive careful consideration at a meeting of the responsible technical committee, which you may attend. If you feel that your comments have not received a fair hearing you should make your views known to the ASTM Committee on Standards, at the address shown below.

This standard is copyrighted by ASTM International, 100 Barr Harbor Drive, PO Box C700, West Conshohocken, PA 19428-2959, United States. Individual reprints (single or multiple copies) of this standard may be obtained by contacting ASTM at the above address or at 610-832-9585 (phone), 610-832-9555 (fax), or service@astm.org (e-mail); or through the ASTM website (www.astm.org).