



Standard Test Method for Dimensional Stability of Fabrics to Changes in Humidity and Temperature¹

This standard is issued under the fixed designation D 6207; the number immediately following the designation indicates the year of original adoption or, in the case of revision, the year of last revision. A number in parentheses indicates the year of last reapproval. A superscript epsilon (ϵ) indicates an editorial change since the last revision or reapproval.

1. Scope

1.1 This test method covers the determination of the dimensional stability of fabrics that are intended for use on panel and screen systems to cycled changes in humidity and temperature.

1.1.1 Panel and screen systems include acoustic panels, free standing screens, office partitions, and furniture systems.

1.2 The values stated in SI units are to be regarded as the standard. The values in parentheses are approximate inch-pound unit equivalents and are for information only.

1.3 *This standard does not purport to address all of the safety concerns, if any, associated with its use. It is the responsibility of the user of this standard to establish appropriate safety and health practices and determine the applicability of regulatory limitations prior to use.*

2. Referenced Documents

2.1 ASTM Standards:²

D 123 Terminology Relating to Textiles

D 4850 Terminology Relating to Fabric³

D 5034 Test Method for Breaking Strength and Elongation of Textile Fabrics (Grab Test)

D 5035 Test Method for Breaking Strength and Elongation of Textile Fabrics (Strip Method)

3. Terminology

3.1 Definitions:

3.1.1 For definitions of textile terms used in this test method; bench mark; dimensional change; dimensional stability; related to textiles, refer to Terminology D 4850

3.1.2 For definitions of other terms related to textiles, refer to Terminology D 123

4. Summary of Test Method

4.1 Dimensional change (growth and shrinkage) data is collected for a specimen of fabric that is subjected to controlled cycles of specified relative humidity and temperature conditions.

5. Significance and Use

5.1 The measured dimensional stability of a fabric determines whether a fabric has the potential to retain its original shape and remain stable, indicating it will not bubble or sag over time, when applied over a substrate, and its suitability for a specified use.

5.2 This test method is recommended for acceptance testing of commercial shipments however, caution is advised since information about between laboratory precision is incomplete. Comparative tests as directed in 5.2.1 are advisable.

5.2.1 If there are differences of practical significance between reported test results for two laboratories (or more), comparative test should be performed to determine if there is a statistical bias between them, using competent statistical assistance. At a minimum, use the samples for such a comparative test that are as homogeneous as possible, drawn from the same lot of material as the samples that resulted in disparate results during initial testing and randomly assigned in equal numbers to each laboratory. The test results from the laboratories involved should be compared using a statistical test for unpaired data, a probability level chosen prior to the testing series. If bias is found, either its cause must be found and corrected, or future test results for that material must be adjusted in consideration of the known bias.

5.3 This test method is used in industry to determine if a fabric grows, grows and then shrinks, shrinks and then grows, or remains the same when subjected to a specified range of humidity and temperature conditions.

6. Apparatus

6.1 *Environmental Test Chamber*, meeting the following criteria:

6.1.1 Capable of testing two specimens at one time, each 150 by 1000, ± 6 mm (6.0 by 39.0, ± 0.25 in.) mounted vertically in a single frame.

¹ This test method is under the jurisdiction of ASTM Committee D13 on Textiles and is the direct responsibility of Subcommittee D13.59 on Fabrics Test Methods.

Current edition approved Oct. 1, 2003. Published October 2003. Originally approved in 1997. Last previous edition approved in 1997 as D 6207 – 97.

² For referenced ASTM standards, visit the ASTM website, www.astm.org, or contact ASTM Customer Service at service@astm.org. For *Annual Book of ASTM Standards* volume information, refer to the standard's Document Summary page on the ASTM website.

³ *Annual Book of ASTM Standards*, Vol 07.02.

6.1.2 Capable of a relative humidity range of 15 to 95%, controllable to $\pm 5\%$.

6.1.3 Capable of a temperature range of 15 to 35 °C (59 to 95 °F) with a tolerance of ± 2 °C (± 4 °F).

6.1.4 Provision for automatic cycling of humidity and temperature conditions.

6.1.5 Having visible humidity and temperature indicators and a continuous recording device (digital readout or plotter).

6.2 *Specimen Frame*, meeting the following criteria:

6.2.1 Of a size that will fit in the test chamber and hold two specimens, see Fig. 1.

6.2.2 With a means for measuring specimen length of at least 1000 mm (36 in.) in increments of 1 mm (0.05 or $\frac{1}{16}$ in.).

6.2.3 With a means for holding and suspending the specimen vertically.

6.3 Pointers, T-shaped or common straight pins, one per specimen, for reference marks.

6.4 A weight spring clamp, with a mass of 100 ± 5 g, one per specimen, to create a uniformly distributed force across the specimen width dimension of $1.00 \text{ N} \pm 0.05 \text{ N}$ (0.22 lbf).

6.4.1 Examples of weighted spring clamps are the paper holders used on the top of clip boards and potato chip bag clamps.

7. Sampling

7.1 *Lot Sample*—Take a lot sample as directed in the applicable material specification. In the absence of such a specification, randomly select the rolls or pieces that constitute the lot sample using the following schedule:

Number of Rolls, Pieces in Lot, Inclusive	Number of Rolls, or Pieces in Lot Sample
1 to 3	All
4 to 24	4
25 to 50	5
Over 50	10 % to a maximum of 10 of the rolls or pieces.

NOTE 1—An adequate specification or other agreement between the purchaser and supplier requires taking into account the variability between rolls of fabric and between specimens from a swatch from a roll of fabric to provide a sampling plan with a meaningful producers risk, consumers risk, acceptable quality level, and limiting quality level.

NOTE 2—The above section is above from Test Methods D 5034 and D 5035.

7.2 *Laboratory Sample*—For a laboratory sample take a swatch extending the full width of the fabric and approximately 1.5 m (1.5 yd) along the length from the lot sample roll/bolt. Take swatches that will exclude the outer or inner layer of fabric.

7.3 *Test Specimens*—From each laboratory sample swatch, cut two specimens, each 150 by 1000 ± 6 mm (6.0 by 39.0 ± 0.25 in.), one cut in the lengthwise direction of the roll, and one cut in the widthwise direction of the roll (across). Take no specimen within 10% of the fabric width from the selvage. Avoid areas with wrinkles.

8. Preparation of Apparatus

8.1 Check all elements of the environmental test chamber to ensure that they are functioning properly. These elements include, but are not limited to, the humidifier, dehumidifier, heater, fan, gages, and recording device.

8.2 Calibrate the test chamber instrumentation as recommended by the manufacturer, to maintain relative humidity and temperature accuracy.

9. Preparation of Test Specimens

9.1 Position and clamp length and width test specimens in the specimen frame. (See Fig. 2).

9.2 Attach a weighted spring clamp to the lower end of each specimen (see 6.4). Do not remove the weighted springs clamps until the test has been completed.

9.3 Precondition the specimens (see 9.2) for 24 h at 15 ± 5 % relative humidity (RH) and 32 ± 2 °C (90 ± 4 °F).

9.3.1 The specimens may be preconditioned in a separate controlled drying oven, a preconditioning oven, or the environmental test chamber.

10. Procedure

10.1 If not already in the test chamber (see 9.3), place the prepared and preconditioned specimens vertically in the test chamber, that has been stabilized at 15 ± 5 % RH, and 32 ± 2 °C (90 ± 4 °F).

10.2 Attach a horizontal pointer to each specimen at the 900 mm (35.0 in.) mark as indicated by the scale.

10.3 Note any observed discoloration, bubbling, or curling of the specimens and the stage of testing at which it was noted.

10.4 Over a 8 h period, increase the humidity to 95 ± 5 % RH and reduce the temperature to 20 ± 2 °C (68 ± 4 °F). Use a uniform rate of change of 10% RH/h and 1.5 °C/h (2.75°F/h).

10.5 At the end of the period record the pointer readings to the nearest 1 mm (0.05 or $\frac{1}{16}$ in.), and the conditions.

10.6 Over the next 16 h decrease the humidity level to 15 ± 5 % RH, and raise the temperature to 32 ± 2 °C (90 ± 4 °F). Use a uniform rate of change of 5% RH/h and 0.75°C/h (1.375°F/h).

10.7 At the end of this period, record the pointer readings to the nearest 1 mm (0.05 or $\frac{1}{16}$ in.), and the conditions.

10.8 Repeat 10.3-10.6 over the next 24 h.

10.9 Remove the specimen frame from the test chamber, the linear weights from the specimens, and the specimens from the frame.

11. Report

11.1 State that the specimens were tested as directed in this test method. Described the material or product sampled and the method of sampling used.

11.2 Report the following information (refer to Fig. 3 for an example of a report layout):

11.2.1 The manufacturer's name, the style, the fiber content of the fabric, and any special treatment (for example, latex backing, stain and soil reducing treatments etc.).

11.2.2 The initial pointer setting for both length and width specimens.

11.2.3 The pointer measurements at the end of the humid and dry phases of the test cycle for both the length and the width specimens (four readings each over two cycles).

11.2.4 If any of the specimens became stable during the test.

11.2.5 Any discoloration, bubbling or curling of the specimens recorded.

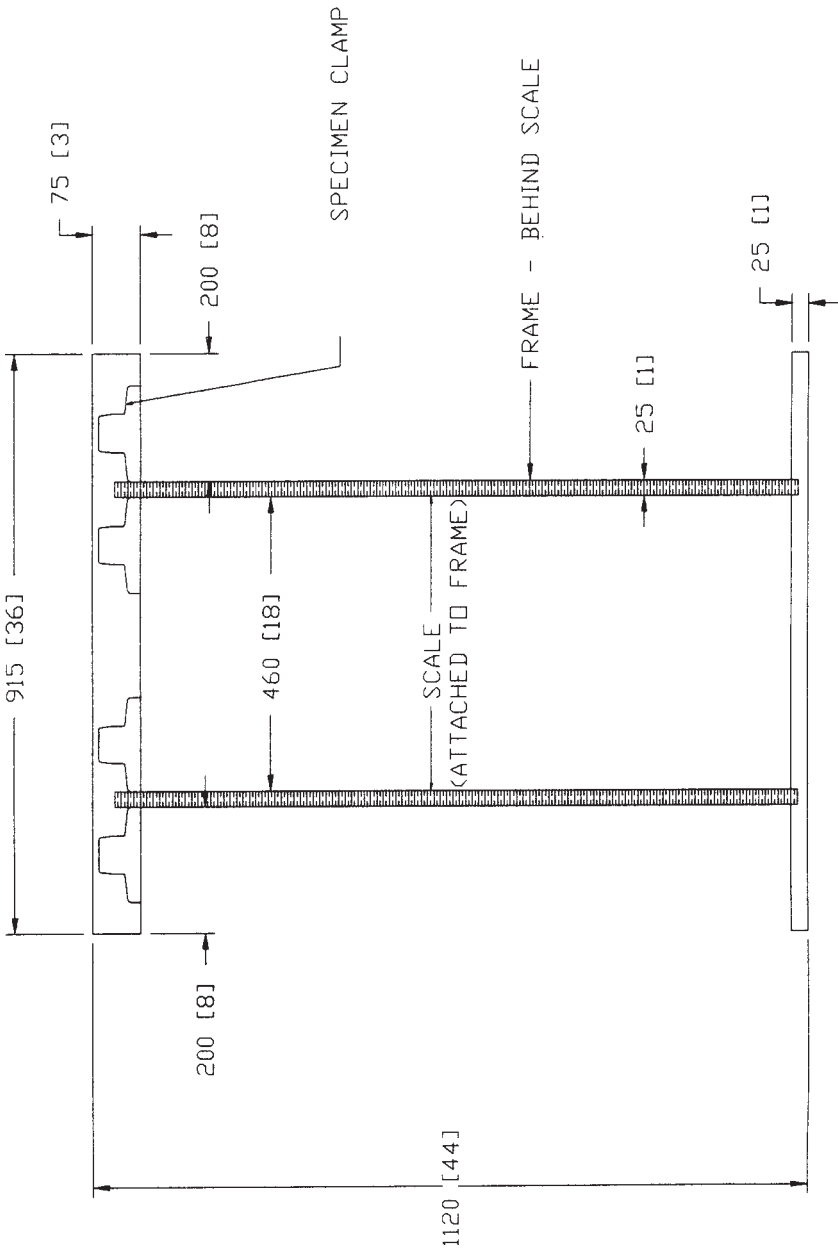

DIMENSION UNITS - mm [INCH]

FIG. 1 Specimen Frame

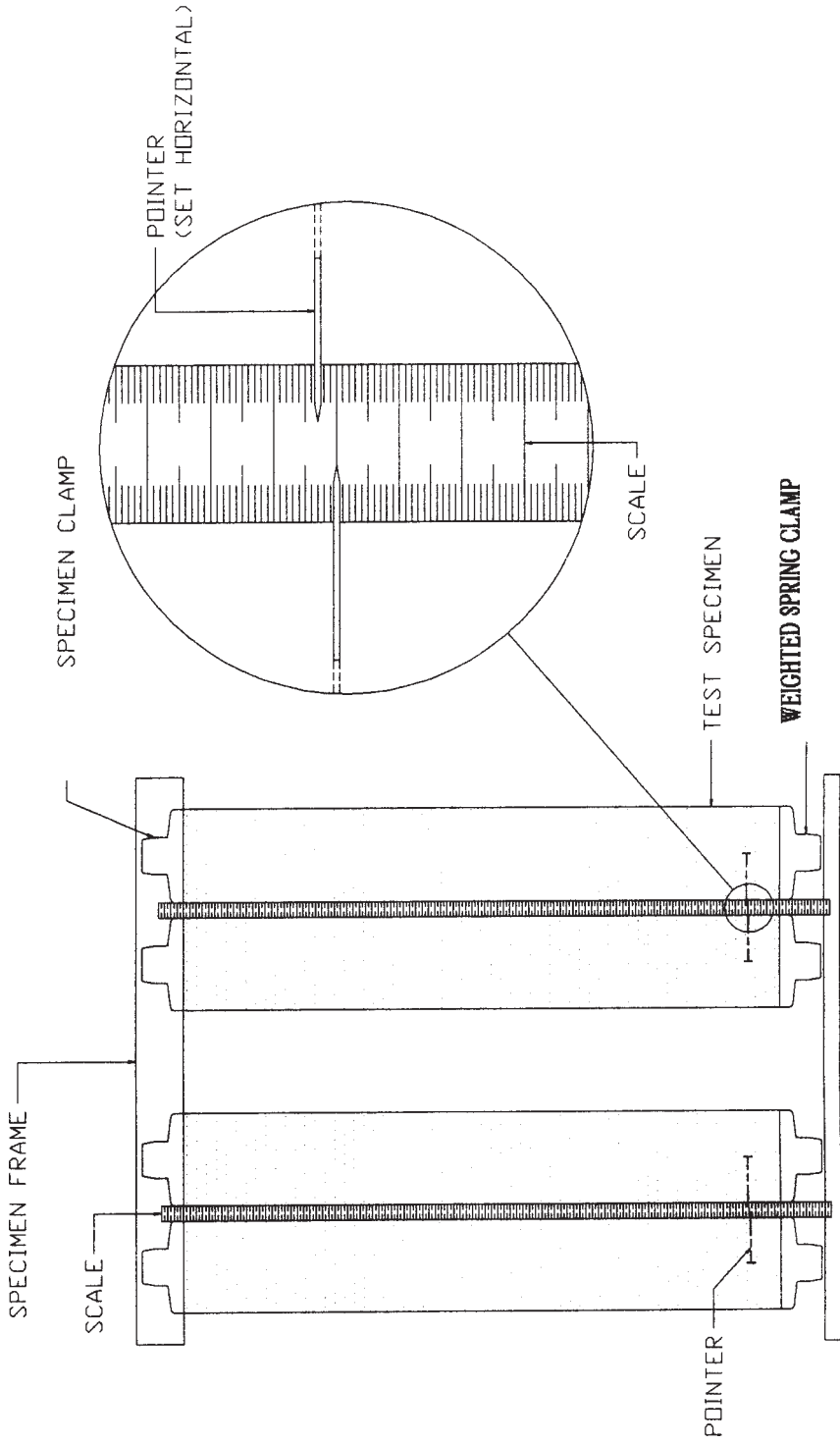

FIG. 2 Specimens Mounted in Specimen Frame

Dimensional Stability of fabrics to changes in humidity and temperature.

METHOD OF SAMPLING USED	
-------------------------	--

MANUFACTURER	
FABRIC NAME/STYLE	
FIBER CONTENT	
FABRIC WIDTH	
SPECIAL TREATMENT	

		CYCLE 1		CYCLE 2	
ASTM D 59-001	Initial Pointer Setting	Pointer Reading at 95% RH & 20°C (68°F).	Pointer Reading at 15% RH & 32°C (90°F).	Pointer Reading at 95% RH & 20°C (68°F).	Pointer Reading at 15% RH & 32°C (90°F).
WIDTHWISE					
LENGTHWISE					
Observations:					

FIG. 3 Example of Report Layout

11.3 Any report layout as shown in Fig. 3 can be used.

12. Precision and Bias

12.1 *Precision*—When the procedure in this test method was used in a single laboratory to measure the various dimensional changes described in 5.2.1, the maximum standard deviation was 0.8 mm (0.03 in.).

12.2 *Bias*—The procedure in this test method for determining the dimensional changes in fabrics due to humidity and

temperature variations has no known bias because the value of the dimensional change is defined only in terms of this test method

13. Keywords

13.1 dimensional change; fabric; humidity; temperature

ASTM International takes no position respecting the validity of any patent rights asserted in connection with any item mentioned in this standard. Users of this standard are expressly advised that determination of the validity of any such patent rights, and the risk of infringement of such rights, are entirely their own responsibility.

This standard is subject to revision at any time by the responsible technical committee and must be reviewed every five years and if not revised, either reapproved or withdrawn. Your comments are invited either for revision of this standard or for additional standards and should be addressed to ASTM International Headquarters. Your comments will receive careful consideration at a meeting of the responsible technical committee, which you may attend. If you feel that your comments have not received a fair hearing you should make your views known to the ASTM Committee on Standards, at the address shown below.

This standard is copyrighted by ASTM International, 100 Barr Harbor Drive, PO Box C700, West Conshohocken, PA 19428-2959, United States. Individual reprints (single or multiple copies) of this standard may be obtained by contacting ASTM at the above address or at 610-832-9585 (phone), 610-832-9555 (fax), or service@astm.org (e-mail); or through the ASTM website (www.astm.org).