



# Standard Test Method for Environmental Stress-Cracking of Ethylene Plastics<sup>1</sup>

This standard is issued under the fixed designation D 1693; the number immediately following the designation indicates the year of original adoption or, in the case of revision, the year of last revision. A number in parentheses indicates the year of last reapproval. A superscript epsilon ( $\epsilon$ ) indicates an editorial change since the last revision or reapproval.

*This standard has been approved for use by agencies of the Department of Defense.*

## 1. Scope \*

1.1 This test method covers the determination of the susceptibility of ethylene plastics, as defined in Terminology D 883, to environmental stress-cracking when subjected to the conditions herein specified. Under certain conditions of stress and in the presence of environments such as soaps, wetting agents, oils, or detergents, ethylene plastics may exhibit mechanical failure by cracking.

1.2 The values stated in SI units are to be regarded as the standard.

1.3 *This standard does not purport to address all of the safety concerns, if any, associated with its use. It is the responsibility of the user of this standard to establish appropriate safety and health practices and determine the applicability of regulatory limitations prior to use.*

NOTE 1—There is no similar or equivalent ISO standard.

## 2. Referenced Documents

### 2.1 ASTM Standards:

- D 618 Practice for Conditioning Plastics and Electrical Insulating Materials for Testing<sup>2</sup>
- D 883 Terminology Relating to Plastics<sup>2</sup>
- D 1204 Test Method for Linear Dimensional Changes of Nonrigid Thermoplastic Sheeting or Film at Elevated Temperature<sup>2</sup>
- D 1248 Specification for Polyethylene Plastics Molding and Extrusion Materials<sup>2</sup>
- D 3350 Specification for Polyethylene Plastics Pipe and Fittings Materials<sup>3</sup>
- D 4703 Practice for Compression Molded Thermoplastic Materials into Test Specimens, Plaques, or Sheets<sup>4</sup>
- D 4976 Specification for Polyethylene Plastics Molding and Extrusion Materials<sup>4</sup>
- E 691 Practice for Conducting an Interlaboratory Study to

Determine the Precision of a Test Method<sup>5</sup>

## 3. Terminology

### 3.1 Definitions:

3.1.1 *stress-crack, n*—an external or internal rupture in a plastic caused by tensile stresses less than its short-time mechanical strength.

3.1.1.1 *Discussion*—The development of such cracks is frequently accelerated by the environment to which the plastic is exposed. The stresses which cause cracking may be present internally or externally, or may be a combination of these stresses. The appearance of a network of fine cracks is called crazing.

3.1.2 *stress-crack failure, n*—for purposes of this test method, any crack visible to an observer with normal eyesight shall be interpreted as a failure of the entire specimen **(1)**.<sup>6</sup> Extension of the controlled imperfection shall not be construed as a failure. The appearance of more than one crack in a single specimen shall be construed as a single failure.

3.1.2.1 *Discussion*—Cracks generally develop at the controlled imperfection and run to the outer edge of the specimen approximately at right angles to it **(2)**. The cracks need not extend completely through the specimen to constitute failure. Cracks sometimes develop under the polymer surface, manifesting themselves as depressions on the surface. The time when this occurs should be noted, and if the depression later develops into a crack, the time of dimpling should be considered as the failure time.

## 4. Summary of Test Method

4.1 Bent specimens of the plastic, each having a controlled imperfection on one surface, are exposed to the action of a surface-active agent. The proportion of the total number of specimens that crack in a given time is observed.

## 5. Significance and Use

5.1 This test method may be used for routine inspection purposes by subjecting a required number of specimens to the test conditions for a specified time and noting the number that

<sup>1</sup> This test method is under the jurisdiction of ASTM Committee D20 on Plastics and is the direct responsibility of Subcommittee D20.15 on Thermoplastic Materials.

Current edition approved June 10, 2001. Published August 2001. Originally published as D 1693 – 59 T. Last previous edition D 1693 – 00.

<sup>2</sup> *Annual Book of ASTM Standards*, Vol 08.01.

<sup>3</sup> *Annual Book of ASTM Standards*, Vol 08.02.

<sup>4</sup> *Annual Book of ASTM Standards*, Vol 08.03.

<sup>5</sup> *Annual Book of ASTM Standards*, Vol 14.02.

<sup>6</sup> The boldface numbers in parentheses refer to the list of references at the end of this test method.

\*A Summary of Changes section appears at the end of this standard.

fail. The cracking obtained with the test reagent is indicative of what may be expected from a wide variety of surface-active agents, soaps, and organic substances that are not absorbed appreciably by the polymer.

5.2 Environmental stress-cracking is a property that is highly dependent upon the nature and level of the stresses applied and on the thermal history of the specimen (1). Under the conditions of the test method, high local multiaxial stresses are developed through the introduction of a controlled imperfection (2,3). Environmental stress-cracking has been found to occur most readily under such conditions.

NOTE 2—Different types of polyethylene plastics as defined in Specification D 1248 are generally tested under different levels of strain and stress. When it is expressly desired to compare the types at equal levels of strain, the specimens for all types should be tested under Condition B, Table 1 (4).

5.3 Information from this test method is not intended to be used for direct application to engineering problems.

NOTE 3—Caution should be used in comparing and ranking various ethylene plastics into distinct and separate groups by this test method (see Section 13 and Note 12).

As thermal history is recognized as an important variable, test results by this test method employing laboratory molded samples cannot necessarily be expected to show agreement with test results from samples obtained by other means. The true performance potential of a given ethylene plastic may, however, best be determined with specimens obtained from commercially prepared items (5).

## 6. Apparatus

6.1 *Blanking Die*—A rectangular die or other means suitable for cutting specimens  $38 \pm 2.5$  mm by  $13 \pm 0.8$  mm ( $1.5 \pm 0.1$  in. by  $0.50 \pm 0.03$  in.). These specimens must be cut with square edges. Beveled ends in particular are to be avoided.

6.2 *Jig*—A jig for making a controlled imperfection in specimens of the dimensions shown in Table 1, parallel to the long edges of the specimen and centered on one of the broad faces. The jig shown in Fig. 1<sup>7</sup> shall be used.

6.3 *Specimen Holders*—Lengths of hard or half-hard brass channel having the dimensions shown in (B) of Fig. 2 shall be used. The sides of the channel shall be parallel and the inside

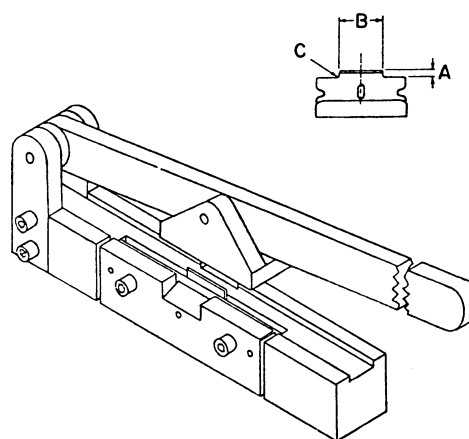

	mm	in.
A	3	1/8
B	18.9–19.2	0.745–0.755
C (radius)	1.5 max	1/16 max

FIG. 1 Nicking Jig

corners sharp and square. Any burrs present on the inside of the channel shall be removed. The inside width is critical (see Dimension F in Fig. 2).

6.4 *Test Tubes*—Hard glass tubes nominally 200 mm long with an outside diameter of 32 mm.

NOTE 4—It is recommended to mount the jig permanently to ensure the notching consistency.

NOTE 5—Hard glass (borosilicate) tubes have been found satisfactory.

6.5 *Corks*—No. 15.

6.6 *Aluminum Foil*—Approximately 0.08 to 0.13 mm (0.003 to 0.005 in.) thick, for wrapping.

6.7 *Constant-Temperature Bath*—A constant-temperature liquid bath maintained at  $50.0 \pm 0.5^\circ\text{C}$  for Conditions A and B of Table 1 and  $100.0 \pm 0.5^\circ\text{C}$  for Condition C of Table 1.

6.8 *Test Tube Rack*—A rack to hold test tubes immersed to reagent level.

6.9 *Bending Clamp*<sup>4</sup>—As shown in Fig. 3.

6.10 *Transfer Tool*<sup>4</sup>—As shown in Fig. 4.

## 7. Reagent

7.1 The test reagent may be a surface-active agent, soap, or any liquid organic substance that is not absorbed appreciably by the polymer.<sup>8</sup>

NOTE 6—This is a nonylphenoxy poly(ethyleneoxy)ethanol. The reagent should be stored in closed metal or glass containers because it is somewhat hygroscopic.

NOTE 7—The manufacturer has stated that this aggressive agent undergoes no known degradation when used as follows: A 10 % volume solution in water at  $50^\circ\text{C}$  for 1000 h of testing.

NOTE 8—The appearance of carbonyl bands in an Igepal Fourier transform infrared (FT-IR) scan is an indication of degradation.

<sup>7</sup> Detail drawings of the apparatus are available from ASTM Headquarters. Request PCN 12-416931-00, 12-416932-00, and 12-416933-00. This apparatus may be purchased from Standard Scientific Supply Co., Bethlehem, PA.

TABLE 1 Standard Test Conditions

Condition		Specimen Thickness		Notch Depth		Bath Temperature, °C
		mm <sup>A</sup>	in.	mm <sup>A</sup>	in.	
A <sup>B</sup>	min	3.00	0.120	0.50	0.020	50
	max	3.30	0.130	0.65	0.025	
B <sup>B</sup>	min	1.84	0.0725	0.30	0.012	50
	max	1.97	0.0775	0.40	0.015	
C <sup>C</sup>	min	1.84	0.0725	0.30	0.012	100 <sup>C</sup>
	max	1.97	0.0775	0.40	0.015	

<sup>A</sup> Dimensional values are not exactly equivalent. However, for referee purposes the metric units shall apply.

<sup>B</sup> For referee purposes, concentration of Igepal will be 10 % volume.

<sup>C</sup> At a temperature of  $100^\circ\text{C}$ , a full-strength reagent, rather than an aqueous solution of a reagent, is generally used because solutions tend to change their compositions by water evaporation losses during the period of test.

<sup>8</sup> For referee purposes Igepal CO-630 should be obtained from Rhone-Poulenc, Prospect Plains, Cranbury, NJ 08512. Use at full strength for Condition C and 10 % volume for Conditions A and B.

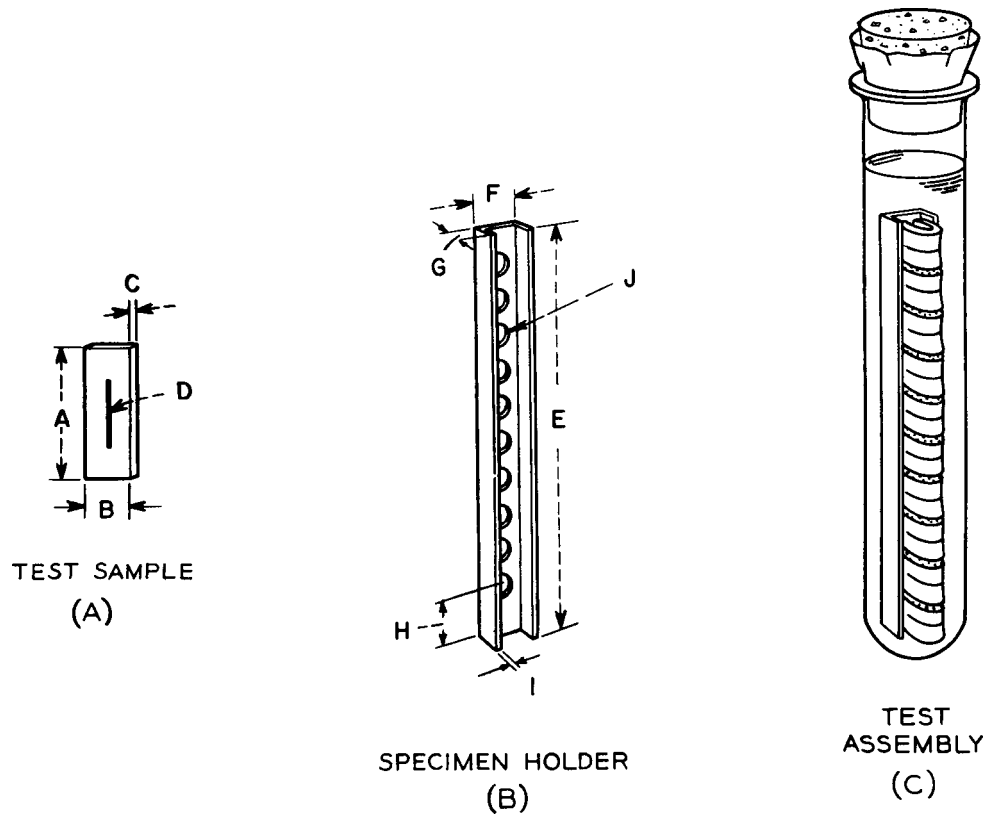

	Dimensions	
	mm	in.
A	38 ± 2.5	1.5 ± 0.1
B	13 ± 0.8	0.5 ± 0.03
C	see Table 1	
D	see Table 1	
E	165	6 1/2
F		
(outside)	16	5/8
(inside)	11.75 ± 0.05	0.463 ± 0.002
G	10	3/8
H	15	37/64
I	2	0.081 (12 B & S)
J	ten 5-mm holes 15-mm centers	ten 3/16-in. holes, 19/32-in. centers

FIG. 2 Test Equipment

## 8. Test Specimen

8.1 Unless otherwise specified, the test specimens shall be molded in accordance with Procedure C of Annex A1 of Practice D 4703.

NOTE 9—Use no liquid release agents, waxes, polishes, etc., when molding. However, inert materials such as polyester film, unplasticized cellophane, polytetrafluoroethylene, and aluminum foil have been found satisfactory.

8.2 Sheets may be examined for internal stresses by taking specimens from random locations in the sheet and placing them in a Petri dish containing 3 mm (1/8 in.) of talc and setting the dish in an air oven at 130°C for Types I and II polyethylene plastic and at 150°C for Types III and IV polyethylene plastic for 30 minutes. If shrinkage of the specimens is less than 10 %

in the lengthwise direction, the molded sheet can be considered satisfactory (see also Test Method D 1204).

8.3 Cut specimens from smooth sheet pressed from granules or mill-massed material to the dimensions given in Fig. 2 (A). Use a die or other device that produces specimens with clean-cut, square, unbeveled edges. The specimens should be cut within 24 h after the sheets are prepared.

## 9. Conditioning

9.1 Unless otherwise specified, the test specimens should be conditioned in accordance with Procedure A of Practice D 618. Do not bend the test specimens, nick, or treat them with the reagent until immediately prior to the test. Testing should be started a minimum of 40 h and a maximum of 96 h after conditioning the specimens has begun.

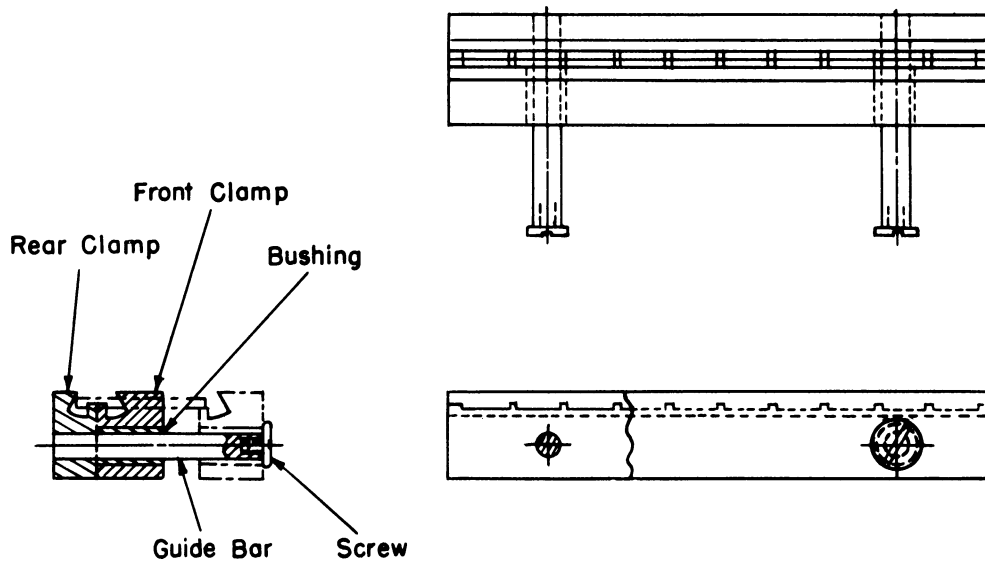
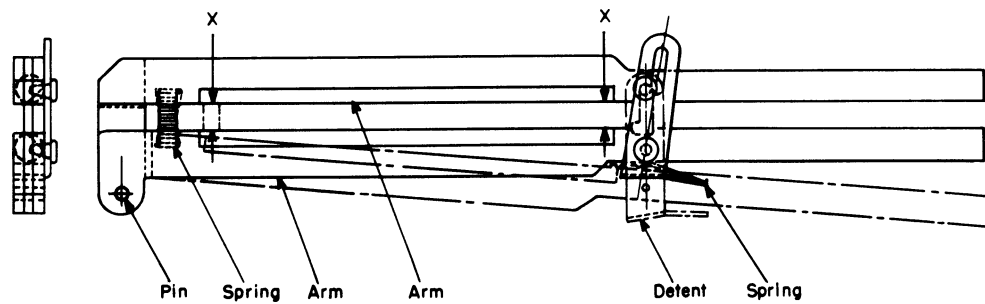

FIG. 3 Bending Clamp Assembly



NOTE 1—X = 10.5 ± 0.5 mm (0.41 ± 0.02 in.)

FIG. 4 Transfer Tool Assembly

## 10. Procedure

10.1 Select the condition desired from Table 1.

NOTE 10—Generally, polyethylene plastics with densities between 0.910 and 0.925 are tested under Condition A. Polyethylenes with densities >0.925 are tested under Condition B. Condition C may be used to accelerate testing for materials with extremely high ESCR values. The user of this test method should refer to the material specifications such as D 1248, D 3350, or D 4976 for specific test conditions.

10.2 Give each conditioned specimen a controlled imperfection (notch) on one surface as shown in (A) of Fig. 2. Use a sharp blade, mounted in the jig shown in Fig. 1, for making this imperfection. A depth micrometer may be used for setting the blade in the jig so that the notch depth is controlled as specified in Table 1. The difference between the height at the top of the blade edge and the channel of the jig where the top of the specimen rests when being nicked is measured to ensure the proper setting of the blade.

NOTE 11—Where it is desired to nick specimens to a notch depth required by Conditions B and C in Table 1 and the available jig has been designed for nicking specimens to a notch depth required by Condition A in Table 1, brass shim stock 0.21 mm (0.008 in.) thick may be used to make the more shallow notch. Brass shim stock is cut wide enough so that it fits snugly inside the jig channel where the specimen rests when nicked. The length of the shim should be such that it extends over the blade, around the end of the jig, and under the end so that the jig will rest on

about 1 or 2 in. of the shim stock. The weight of the jig resting on the shim stock prevents deformation of the shim stock during the nicking operation. An oblong hole long enough to fit completely over the protruding blade is cut in the other end of the shim stock. Discard shim stock that becomes wrinkled or deformed in such a way as to prevent the specimen from lying horizontal in the jig.

NOTE 12—In order to maintain notch consistency, it is recommended to keep the force applied to the jig handle constant. This can be done by applying the force at the same location of the jig handle each time using a torque wrench.

NOTE 13—The notch depth correlates with the depth of blade setting, which is measured by a depth micrometer (see 10.2). The notch depth can be verified by microtoming the cross section of the specimen followed by examining the slice under microscope. It also can be done by fracturing a notched specimen after it is cooled with liquid nitrogen then examine the fracture surface under microscope.

NOTE 14—Check notch quality for straight edge, sharp notch and free of stress concentration area by examining the cross section of the specimen under microscope equipped with a polarized light.

10.3 Inspect the edge of the blade for notches and burrs under normal vision prior to the first nicking and at least after each 30 successive nicks have been performed. In no case shall a blade be used for more than 100 specimens. Replace the blade whenever there is any question of its having become dull or damaged.

10.4 Place ten specimens, with the controlled imperfection up, in the slots provided in the bending clamp. Close the clamp

by means of a vise, arbor press, or other suitable aid, taking 30 to 35 s for the complete closing operation. Place the transfer tool in position on top of the closed clamp and close it over the specimens. Then lift the specimens from the clamp with the transfer tool and place them in the channel by releasing the transfer tool. The ends of all the specimens should rest against the base of the brass channel. If some specimens are riding too high in the holder they should be forced down by manual pressure.

10.5 Not more than 10 min after the specimens have been bent into the holder, insert the holder in the test tube. Then immediately fill the tube to approximately 13 mm (0.5 in.) above the top specimen with fresh reagent which is at a temperature of  $23 \pm 1^\circ\text{C}$  ( $73.4 \pm 1.8^\circ\text{F}$ ). Stopper the tube with a foil-wrapped cork and immediately place it in the constant-temperature bath at the preselected test temperature. The controlled imperfections should not be touching the test tube during the test.

NOTE 15—The heat capacity and the heat input capacity of the bath should be high enough so that the temperature does not drop more than  $1^\circ\text{C}$  when the samples are added.

10.6 Inspect the test specimen at indicated elapsed times and record the total number of failures at the time.

10.7 Obtain the failure point in one of the following three ways:

10.7.1 Percentage of failure at the end of the intervals specified for the material under test, for example, 50 % failure at 24 h.

10.7.2 Estimated failure time in hours when a percentage of failure occurs by observation. This is designated as  $fp$  where  $p$  is the percentage of specimen failure.  $f_{50}$  will be the time when the fifth specimen fails in a ten-specimen test.

10.7.3 Estimated failure time in hours when a percentage of failure occurs by graphical calculation as described in Annex A1. This is designated as  $Fp$  where  $p$  is the percentage of specimen failure.  $F_{50}$  will be the calculated time at the 50 % line on the probability graph.

### 11. Routine Inspection and Acceptance

11.1 For routine inspection of materials it shall be satisfactory to accept lots on the basis of testing at least ten specimens for a specified time.

### 12. Report

12.1 Report the following information:

12.1.1 Complete identification of material tested,

12.1.2 Manner of preparation of test sheets (that is, from granules or from milled crepe),

12.1.3 Reagent and strength,

12.1.4 Condition of test from Table 1,

12.1.5 Duration of test in hours,

12.1.6 Percentage of specimens that fail at a designated time, estimated failure time in hours by observation ( $fp$ ), or estimated failure time in hours by graphical calculation ( $Fp$ ).

12.1.7 Date of test.

### 13. Precision and Bias<sup>9</sup>

13.1 *Precision*—Table 2 is based on a round robin conducted in 1995 in accordance with Practice E 691, involving five materials tested by seven laboratories. Each material was compression molded by one laboratory and the individual specimens were cut and notched by the laboratory that tested them. Each material was tested twice by each laboratory.

NOTE 16—The following explanation of  $r$  and  $R$  (13.2 through 13.2.4) are intended only to present a meaningful way of considering the approximate precision of this test method. The data in Table 1 should not be applied rigorously to acceptance or rejection of material, as those data are specific to the round robin and may not be representative of other lots, conditions, materials, or laboratories.

13.2 Users of this test method should apply the principles outlined in Practice E 691 to generate data specific to their laboratory and materials, or between specific laboratories. The principles of 13.2.1 through 13.2.4 would then be valid for such data.

13.2.1 *Concept of Repeatability (r) and Reproducibility (R)*—If  $S_r$  and  $S_R$  have been calculated from a large enough body of data, then judge the test results as follows:

13.2.2 *Repeatability (r)*—The two test results should be judged not equivalent if they differ by more than the  $r$  value for the material.

13.2.3 *Reproducibility (R)*—The two test results should be judged not equivalent if they differ by more than the  $R$  value of the material.

13.2.4 Any judgement made in accordance with 13.2.2 and 13.2.3 would have an approximate 95 % probability of being correct.

13.3 *Bias*—There are no recognized standards on which to base an estimate of bias for this test method.

### 14. Keywords

14.1 environmental resistance; polyethylene; stress-cracking

<sup>9</sup> Data are available from ASTM Headquarters. Request RR: D20-1008.

**TABLE 2 ESCR of Polyethylene,  $F_{50}$  in Hours**

Sample	Ave. $F_{50}$ , h	$S_r$	$S_R$	$r$	$R$	$S_r/X$	$S_R/X$
Resin A, molded plaques	49.6	3.7	19.1	10.5	54.1	7.5 %	39 %
0.945/0.3 extruded sheets	52.7	2.3	28.8	6.5	81.5	4.4 %	55 %
Resin B, molded plaques	42.0	3.4	14.2	9.6	40.2	8.1 %	34 %
0.950/0.06 extruded sheets	49.1	8.0	14.2	22.6	40.2	16 %	29 %

**(Mandatory Information)**
**A1. GRAPHICAL METHOD OF DETERMINING FAILURE POINTS**

A1.1 Under some circumstances a 50 % failure point ( $F_{50}$ ) is of interest and relevant, as other failure points may be. An example of calculation using a graphical method for the 50 % (or almost any other %) failure point is as follows:

A1.1.1 The value reported by this graphical method is obtained without reference to 0 % failure time. Plot the data on logarithmic probability graph paper, Fig. A1.1 or Fig. A1.2, with appropriate time scales chosen and probability expressed as percentage. (The user is encouraged to copy these figures.) Elapsed time belongs on the logarithmic scale. Number of failures (breaks or cracks), divided by one more than the number of original specimens, belongs on the probability scale. Adding one to the number of specimens provides a divisor that (a) produces a symmetrical treatment of the data, (b) enables plotting all the data points, (c) is easy to remember without a table, (d) permits using any otherwise appropriate number of specimens, and (e) is widely accepted.

NOTE A1.1—This plotting convention does not necessarily provide a mathematically optimum unbiased estimate of the standard deviation, but using the convention appears nearly optimal with ten specimens. Considerable mathematical bias is usually introduced anyway by the economic necessity of periodic inspection, that is, not continuously watching for breaks during 48 h. The recorded failure times are generally later than the actual failure times. This limitation seems to engulf the slight bias introduced for convenience by the plotting convention (6), (7). For further information see Refs 6–9 and the references contained therein.

A1.2 If one or more specimens broke since the previous observation, plot a point for each of the failed specimens. Therefore, one point will appear for each specimen that fails. A point does not necessarily appear for each observation time. Draw the best-fitting straight line for the plot. The time indicated at the intersection of the data line and the 50 % probability line shall be the 50 % failure point ( $F_{50}$ ). Similarly,  $F_{10}$ ,  $F_{20}$ ,  $F_{90}$ , or  $F_x$  information is obtained from the intersection of the data line and the 10 %, 20 %, 90 %, or X %

probability lines. The  $F_0$  and  $F_{100}$  points cannot be obtained, as they do not formally exist.

A1.3 A specimen that breaks on bending is called failed at 1 min, or less, an arbitrary convenient short time that is less than the first inspection time. The plotting directions are then still valid. Convenient suitable inspection times have been found to be 0.1, 0.25, 0.5, 1.0, 1.5, 2, 3, 4, 5, 8, 16, 24, 32, 40, and 48 h. Extended tests are inspected every 24 h thereafter. Certain work schedules would eliminate the 16 and 32-h inspections, and possibly shorten the 8, 24, and 48-h periods a few minutes to enable inspection during an 8-h working day. Laboratories on round-the-clock operations would not be affected by this problem.

A1.4 Specific examples of calculations using the graphical method, in conjunction with Fig. A1.3, are given in Table A1.1.

A1.5 Avoid overextrapolation when using this graphical method. In case of unreasonably extended life of some specimens, the test may be terminated before all specimens have failed. The available data may then be plotted. Reduced precision may result.

A1.6 Generally ten specimens are used so that ten points appear on the graph. Occasionally a specimen may be irretrievably lost. The plotting positions on the probability scale change, but the instructions remain the same.

NOTE A1.2—Some possible hints on fitting lines by eye are given in Refs (6) and (7).

A1.7 After experience with the test method and graphical procedures, an occasional outlier specimen may be noted that violates credibility. The plotting procedure should be reasonable in such cases. A conceivable situation exists, however, in which the apparent outlier is the only point of interest.

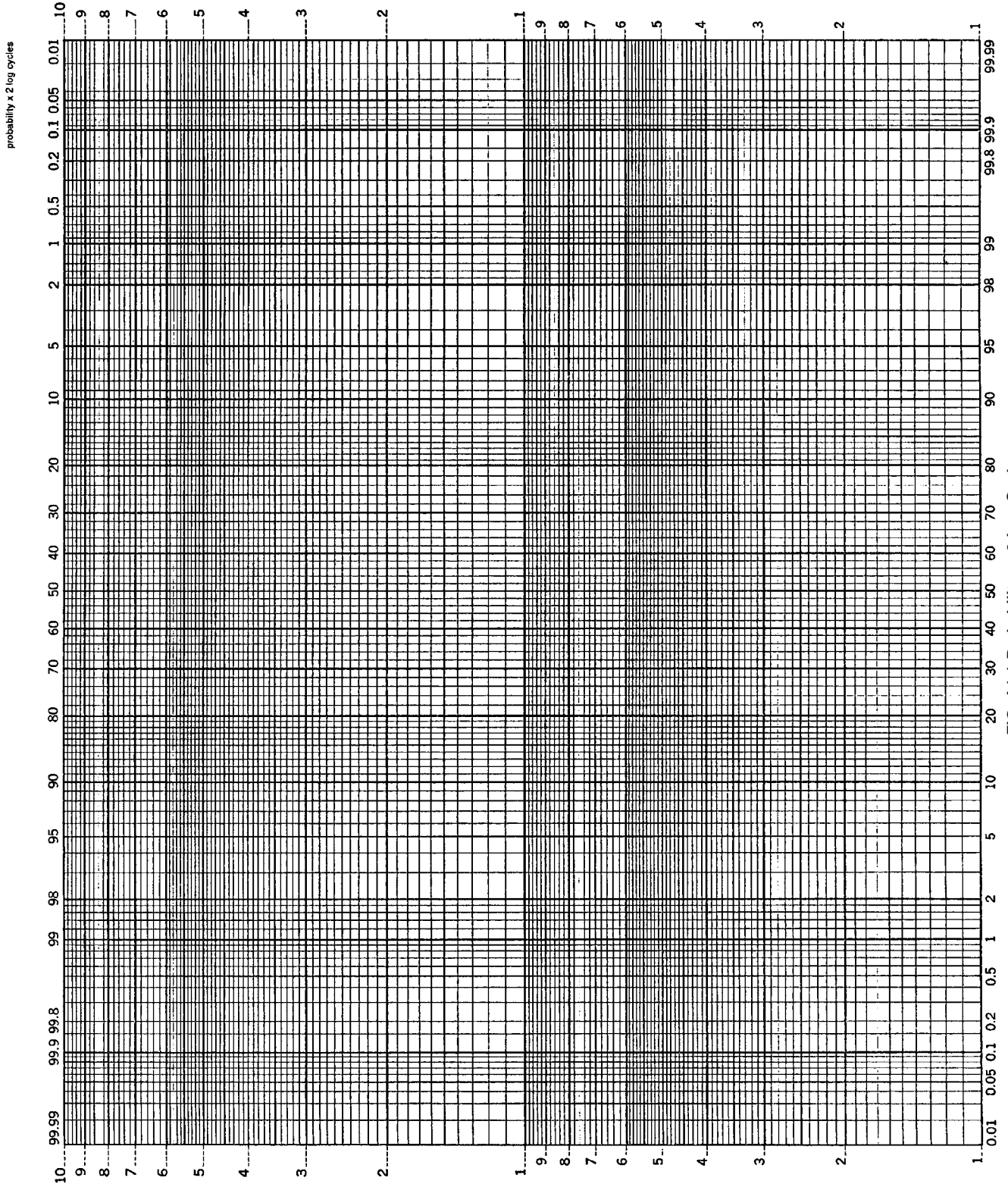

FIG. A1.1 Probability x 2 Log Cycles

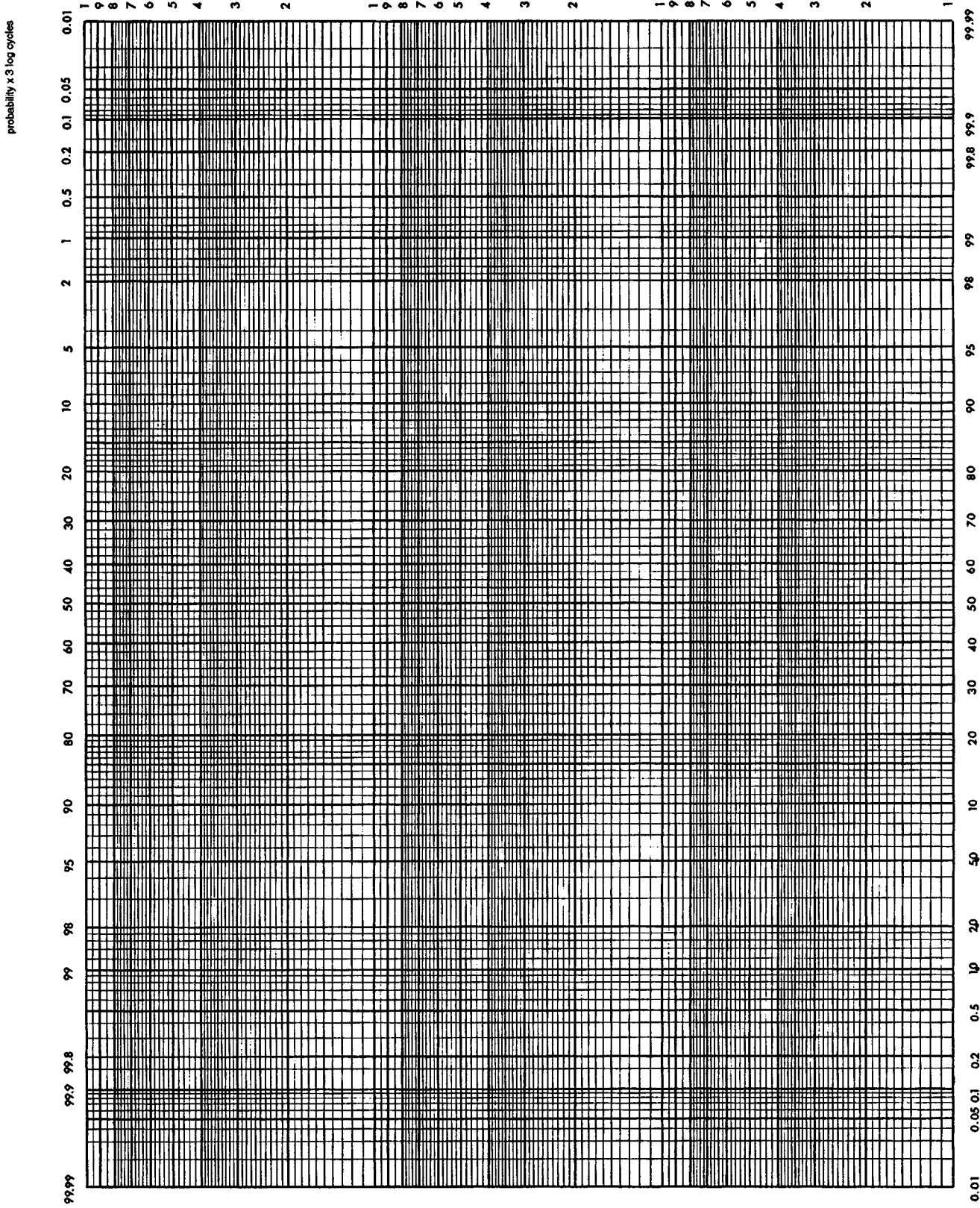

FIG. A1.2 Probability  $\times$  3 Log Cycles

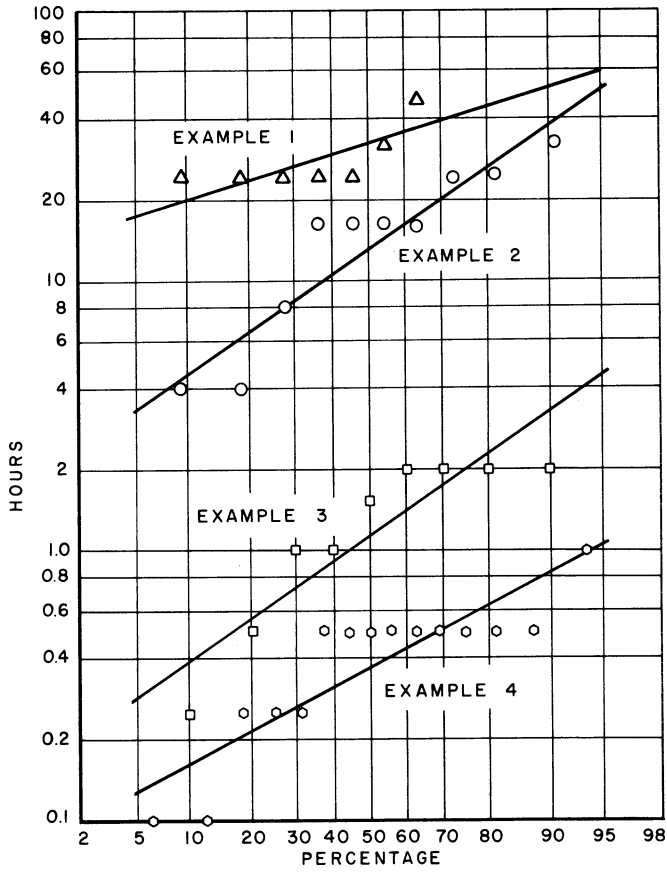

FIG. A1.3 Graphical Method for Determining Failure Points

**TABLE A1.1 Examples of Calculations**

NOTE 1—Integers in the upper part of the body of the table show the number of specimens failed at the indicated elapsed time.

	Elapsed Time, h														
	0.1	0.25	0.5	1	1.5	2	3	4	6	8	16	24	32	40	48
Example 1 (three specimens do not fail in time)	0	0	0	0	0	0	0	0	0	0	0	5	6	6	7
Example 2 (ten specimens)	0	0	0	0	0	0	0	2	2	3	7	9	10	<sup>A</sup>	
Example 3 (nine specimens; one lost)	0	1	2	4	5	9	<sup>A</sup>								
Example 4 (15 specimens; special ESCR)	2	5	14	15	<sup>A</sup>										
percentage plotting positions for Example 4	6.2	18.8	37.5	93.8	none										
	12.5	25.0	43.8												
		31.2	50.0												
			56.2												
			62.5												
			68.8												
			75.0												
			81.2												
			87.5												

<sup>A</sup> Stop test since all available specimens failed.

## APPENDIX

### (Nonmandatory Information)

#### X1. ADDITIONAL INFORMATION

**TABLE X1.1 ESCR of Polyethylene,  $F_{50}$  in Hours (From D 1693–99)<sup>A</sup>**

Material	Density, $I_2$ (g/mL, g/10 min)	Average, $\bar{X}$	$S_r^B$	$S_R^C$	$t^D$	$R^E$
A	0.935, 5.5	44.9	26.0	41.8	72.8	117.2
B	0.941, 3.0	102.4	40.9	70.3	114.5	196.7
C	0.955, .50	227.9	28.0	153.4	78.4	429.5
D	0.947, .32	43.0	2.75	19.5	7.70	54.6
E	0.935, .40	22.1	2.95	10.6	8.4	29.9

<sup>A</sup> Test Method D 1693, Condition B, 10 % Igepal CO-630.

<sup>B</sup>  $S_r$  = the within-laboratory standard deviation of the average.

<sup>C</sup>  $S_R$  = the between-laboratories standard deviation of the average.

<sup>D</sup>  $t$  = repeatability limit =  $2.83 \times S_r$ .

<sup>E</sup>  $R$  = reproducibility limit =  $2.83 S_R$ .

**TABLE X1.2 Variables of the Test**

Variables Mostly Likely to Influence the Precision and Bias of the Test (variables were studied within the specifications called by the test procedure)		
Item	Descriptions	Remarks
1	Thermal history/crystallinity: press cool down rate specimen conditioning	Small effect, low crystallinity gives longer failure time
2	Time elapsed between successive operations; notching, bending and testing	Relatively insignificant
3	Jaw separation of bending and transferring tools	Not studied
4	Stress at the point of crack initiation: rate the bending clamp is closed, 30 to 35 s dimension of specimen holder, 11.70 to 11.80 mm	important, must stay in range relatively insignificant
5	Specimen thickness, 1.75 to 2.00 mm	Very significant, especially for materials with high yield stress thicker specimens crack faster but have smaller standard deviation
6	Notch depth, 0.030 to 0.040 mm	Very significant, hardware controlled
7	Sharpness of blade, max 100 notches	Relatively insignificant
8	Igepal concentration, no range specified 100 % 10 % in water	Moisture effect: significant insignificant from 7.5 to 12.5 %
9	Calculation: manual versus graphical	Generally insignificant but depends on the frequency of reading
10	Statistical fluctuation arising from limited number of specimens tested and from stress relaxation during the test	Not evaluated

## REFERENCES

- (1) DeCoste, J. B., Malm, F. S., and Wallder, V. T. *Industrial and Engineering Chemistry*, Vol 43, 1951, p. 117.
- (2) Hopkins, I. L., Baker, W. O., and Howard, J. B. *Journal of Applied Physics*, Vol 21, No. 3, March 1950, pp. 206–213.
- (3) Carey, R. H. “Stress-Cracking of Polyethylene,” *ASTM Bulletin*, No. 167, July 1950, p. 56.
- (4) McTigue, F. H. “Environmental Stress-Cracking Resistance of High Density Polyethylene,” *Plastic Technology*, Vol 5, February 1959, pp. 35–39.
- (5) “Fracture,” *Encyclopedia of Polymer Science and Technology*, Vol 7, pp. 288–289.
- (6) Chernoff, H., and Lieberman, G. J. “Use of Normal Probability Paper,” *Journal of the American Statistical Association*, Vol 49, December 1954, pp. 778–785.
- (7) O. L. Davies, ed., *Statistical Methods in Research and Production*, Hafner Publishing Co., New York, 1961, p. 175.
- (8) Ferrell, E. B. “Plotting Experimental Data on Normal or Log-Normal Probability Paper,” *Industrial Quality Control*, IQCOA, Vol XV, No. 1, July 1958, pp. 12–15.
- (9) Kimball, B. F. “On the Choice of Plotting Positions on Probability Paper,” *Journal of the American Statistical Association*, JSTNA, Vol 55, September 1960, pp. 546–560.

## SUMMARY OF CHANGES

Committee D20 has identified the location of selected changes to this test method since the last issue that may impact the use of this test method.

*D 1693 – 97a:*

(1) Modified precision and bias section.

*D 1693 – 98:*

(1) Note 9 was modified.

*D 1693 – 99:*

(1) Changed 10.6 to 10.6 and 10.7 to better define the data reporting method.

(2) Revised 12.1.6.

(3) Changed Appendix X1 to Annex A1 as its information is

considered mandatory.

*D 1693 – 00:*

(1) Reduced the specimen thickness range of Condition B and added a new precision and bias statement.

(2) Outlined the possible effect of testing parameters.

*D 1693 – 01:*

(1) Revised the specimen thickness for Condition C in Table 1.

(2) Paragraph A1.1.1 was modified to recognize the addition of Figs. A1.1 and A1.2 for a source of graph paper.

*ASTM International takes no position respecting the validity of any patent rights asserted in connection with any item mentioned in this standard. Users of this standard are expressly advised that determination of the validity of any such patent rights, and the risk of infringement of such rights, are entirely their own responsibility.*

*This standard is subject to revision at any time by the responsible technical committee and must be reviewed every five years and if not revised, either reapproved or withdrawn. Your comments are invited either for revision of this standard or for additional standards and should be addressed to ASTM International Headquarters. Your comments will receive careful consideration at a meeting of the responsible technical committee, which you may attend. If you feel that your comments have not received a fair hearing you should make your views known to the ASTM Committee on Standards, at the address shown below.*

*This standard is copyrighted by ASTM International, 100 Barr Harbor Drive, PO Box C700, West Conshohocken, PA 19428-2959, United States. Individual reprints (single or multiple copies) of this standard may be obtained by contacting ASTM at the above address or at 610-832-9585 (phone), 610-832-9555 (fax), or [service@astm.org](mailto:service@astm.org) (e-mail); or through the ASTM website ([www.astm.org](http://www.astm.org)).*