



Designation: D 1708 – 96

Standard Test Method for Tensile Properties of Plastics By Use of Microtensile Specimens¹

This standard is issued under the fixed designation D 1708; the number immediately following the designation indicates the year of original adoption or, in the case of revision, the year of last revision. A number in parentheses indicates the year of last reapproval. A superscript epsilon (ϵ) indicates an editorial change since the last revision or reapproval.

This standard has been approved for use by agencies of the Department of Defense.

1. Scope

1.1 This test method covers certain material specifications for which a history of data has been obtained using the standard microtensile specimen. The specimen geometry has been changed to be equivalent to that of ISO 12086-2:1955. In general, this test method is superseded for general use by either Test Methods D 882 or Test Method D 638. The very small Type V specimen in Test Method D 638 is the recommended specimen when limited amounts of material are available.

1.2 This test method covers the determination of the comparative tensile strength and elongation properties of plastics in the form of standard microtensile test specimens when tested under defined conditions of pretreatment, temperature, humidity, and testing machine speed. It can be used for specimens of any thickness up to 3.2 mm ($\frac{1}{8}$ in.), including thin films.

1.3 This test method cannot be used for the determination of modulus of elasticity. For the determination of modulus, see Test Method D 638 or Test Methods D 882.

1.4 Test data obtained by this test method are relevant and appropriate for use in engineering design.

1.5 The values stated in SI units are to be regarded as the standard. The values given in parentheses are for information only.

1.6 *This standard does not purport to address all of the safety concerns, if any, associated with its use. It is the responsibility of the user of this standard to establish appropriate safety and health practices and determine the applicability of regulatory limitations prior to use.*

NOTE 1—There is no equivalent or similar ISO standard.

2. Referenced Documents

2.1 ASTM Standards:

D 618 Practice for Conditioning Plastics and Electrical Insulating Materials for Testing²

D 638 Test Method for Tensile Properties of Plastics²

D 882 Test Methods for Tensile Properties of Thin Plastic Sheet²

D 883 Terminology Relating to Plastics²

D 4000 Classification System for Specifying Plastic Materials³

D 4066 Specification for Nylon Injection and Extrusion Materials³

E 691 Practice for Conducting an Interlaboratory Study to Determine the Precision of a Test Method⁴

2.2 ISO Standard:

ISO 12086-2:1995 Plastics—Fluoropolymer Dispersion, Moulding, and Extrusion Materials—Part 2 Preparation of Test Specimens and Determination of Properties⁵

3. Terminology

3.1 *Definitions:* Definitions of terms applying to this test method appear in Terminology D 883 and Test Method D 638, Annex A2.

4. Significance and Use

4.1 This test method provides data for quality control and acceptance or rejection under specifications.

4.2 For many materials, there may be a specification that requires the use of this test method, but with some procedural modifications that take precedence when adhering to the specification. Therefore, it is advisable to refer to that material specification before using this test method. Table 1 of Classification System D 4000 lists the ASTM materials standards that currently exist.

5. Apparatus

5.1 The apparatus shall be as specified in Test Method D 638, with the following exceptions:

5.1.1 *Grips*—Serrated grips should be used with care, since yielding or tearing at the grips may interfere with measurement of elongation even when the specimen breaks in the reduced section. Rubber-faced grips are recommended for thin specimens. Self-tightening grips of the “V”-design type are not

¹ This test method is under the jurisdiction of ASTM Committee D-20 on Plastics and is the direct responsibility of Subcommittee D20.10 on Mechanical Properties.

Current edition approved May 10, 1996. Published July 1996. Originally published as D 1708 – 59 T. Last previous edition D 1708 – 95.

² *Annual Book of ASTM Standards*, Vol 08.01.

³ *Annual Book of ASTM Standards*, Vol 08.02.

⁴ *Annual Book of ASTM Standards*, Vol 14.02.

⁵ Available from American National Standards Institute, 11 W. 42nd St., 13th Floor, New York, NY 10036.

TABLE 1 Tensile Strength at Break for Seven Laboratories and Two Materials, MPa

Material	Test Speed, mm/min	Average	S_r^A	S_R^B	r^C	R^D
Polyamide(imide)	1.3	193.6	1.60	5.48	4.48	15.3
Polybutylene	12.7	31.3	0.80	2.75	9.12	9.12

^A S_r is the within-laboratory standard deviation for the indicated material. It is obtained by pooling the within-laboratory standard deviations of the test results from all of the participating laboratories:

$$S_r = \left[\frac{(S_1)^2 + (S_2)^2 + \dots + (S_n)^2}{n} \right]^{1/2} \quad (1)$$

^B S_R is the between-laboratories reproducibility, expressed as a standard deviation, for the indicated material.

^C r is the within-laboratory repeatability limit, $r = 2.8 \times S_r$.

^D R is the between-laboratory reproducibility limit, $R = 2.8 \times S_R$.

satisfactory for this test method because of the change in grip separation that occurs as they bite on the specimen. If the specimen tab is not long enough to prevent the grip faces from cocking, shims should be inserted to provide more uniform clamping.

5.1.2 Drive Mechanism—The velocity of the drive mechanism shall be regulated as specified in Section 8.

5.1.3 The fixed and movable members, drive mechanism, and grips should be constructed of such materials and in such proportions that, after grip slack is taken up, the total elastic longitudinal deformation of the system constituted by these parts does not exceed 1 % of the total longitudinal deformation between the grips at any time during the test. If this is not possible, appropriate corrections shall be made in the calculation of strain values.

5.1.4 Extension Indicator—The extension indicator shall be capable of determining the distance between grips at any time during the test. The instrument shall be essentially free of inertia lag at the specified speed of testing, and shall be accurate to ± 1 % of extension or better.

NOTE 2—It is desirable that the load indicator and the extension indicator be combined into one instrument, which automatically records the load as a function of the extension or as a function of time. In the latter case, the conversion to a load-extension record can readily be made because extension is proportional to time after the take-up of the initial grip slack.

NOTE 3—Extension may also be measured by timing the test with a stop watch and calculating the distance of crosshead movement during that time. Time shall be taken from the instant that the machine records a load on the specimen to the instant the specimen breaks.

5.1.5 Micrometers—Micrometers shall read to 0.0025 mm (0.0001 in.) or less.

6. Test Specimens

6.1 Microtensile test specimens shall conform to the dimensions shown in Fig. 1. This specimen shall be prepared by die-cutting or machining from sheet, plate, slab, or finished article. Dimensions of a die suitable for preparing die-cut specimens are also shown in Fig. 1. Specimens may also be prepared by injection molding or compression molding.

6.2 All surfaces of the specimen shall be free of visible flaws, scratches, or imperfections. Marks left by coarse machining operations shall be carefully removed with a fine file or abrasive, and the filed surfaces shall then be smoothed with abrasive paper (No. 00 or finer). The finishing sanding strokes shall be made in the direction parallel to the long axis of the test specimen.

NOTE 4—Tabs shown in Fig. 1 are minimum size for adequate gripping. Shims may be required with thicker specimens to keep grips from cocking. Handling is facilitated and gripping improved by the use of larger tabs wherever possible.

7. Number of Test Specimens

7.1 At least five test specimens shall be tested for each sample in the case of isotropic materials.

7.2 Ten test specimens, five normal to and five parallel to the principal axis of anisotropy, shall be tested for each sample in the case of anisotropic materials.

7.3 Results obtained on test specimens that break at some obvious fortuitous flaw or at the edge of the grips shall be discarded and retests made, unless such flaws constitute a variable, the effect of which it is desired to study.

8. Speed of Testing

8.1 Speed of testing is the velocity of separation of the two members (or grips) of the testing machine when running idle (under no load).

8.2 The speed of testing shall be chosen such that the rate of straining shall be approximately the same as the rate of straining obtained when the material is tested at the designated speed according to Test Method D 638. Speeds giving rates of straining approximating those given in Test Method D 638 are as follows:

Speed A	0.25 mm (0.01 in.)/min
Speed B	1 to 1.3 mm (0.04 to 0.05 in.)/min
Speed C	10 to 13 mm (0.4 to 0.5 in.)/min
Speed D	100 to 130 mm (4 to 5 in.)/min

These speeds are 0.20 to 0.25 times the speeds designated in Test Method D 638, since the effective gage length of bars specified in the latter test method is 4 to 5 times that of the microtensile test specimens. When the speed of testing is not specified, Speed B shall be used.

9. Conditioning

9.1 Conditioning—Condition the test specimens at $23 \pm 2^\circ\text{C}$ ($73.4 \pm 3.6^\circ\text{F}$) and 50 ± 5 % relative humidity for not less than 40 h prior to test in accordance with Procedure A of Practice D 618 for those tests where conditioning is required. In cases of disagreement, the tolerances shall be $\pm 1^\circ\text{C}$ ($\pm 1.8^\circ\text{F}$) and ± 2 % relative humidity.

9.1.1 Note that for some hygroscopic materials, such as nylons, the material specifications (for example, Specification D 4066) call for testing “dry as-molded specimens.” Such requirements take precedence over the above routine preconditioning to 50 % relative humidity and require sealing the specimens in water vapor-impermeable containers as soon as molded and not removing them until ready for testing.

9.2 Test Conditions—Conduct tests in the standard laboratory atmosphere of $23 \pm 2^\circ\text{C}$ ($73.4 \pm 3.6^\circ\text{F}$) and 50 ± 5 % relative humidity, unless otherwise specified in the test methods. In cases of disagreements, the tolerances shall be $\pm 1^\circ\text{C}$ ($\pm 1.8^\circ\text{F}$) and ± 2 % relative humidity.

10. Procedure

10.1 Test specimens shall be tested at the standard laboratory atmosphere as defined in Practice D 618.

10.2 Measure and record the minimum value of the cross-sectional area of each specimen. Measure the width to the

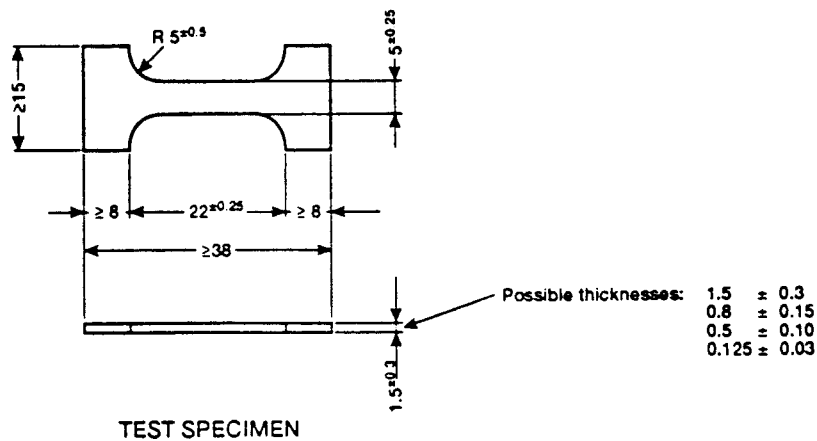
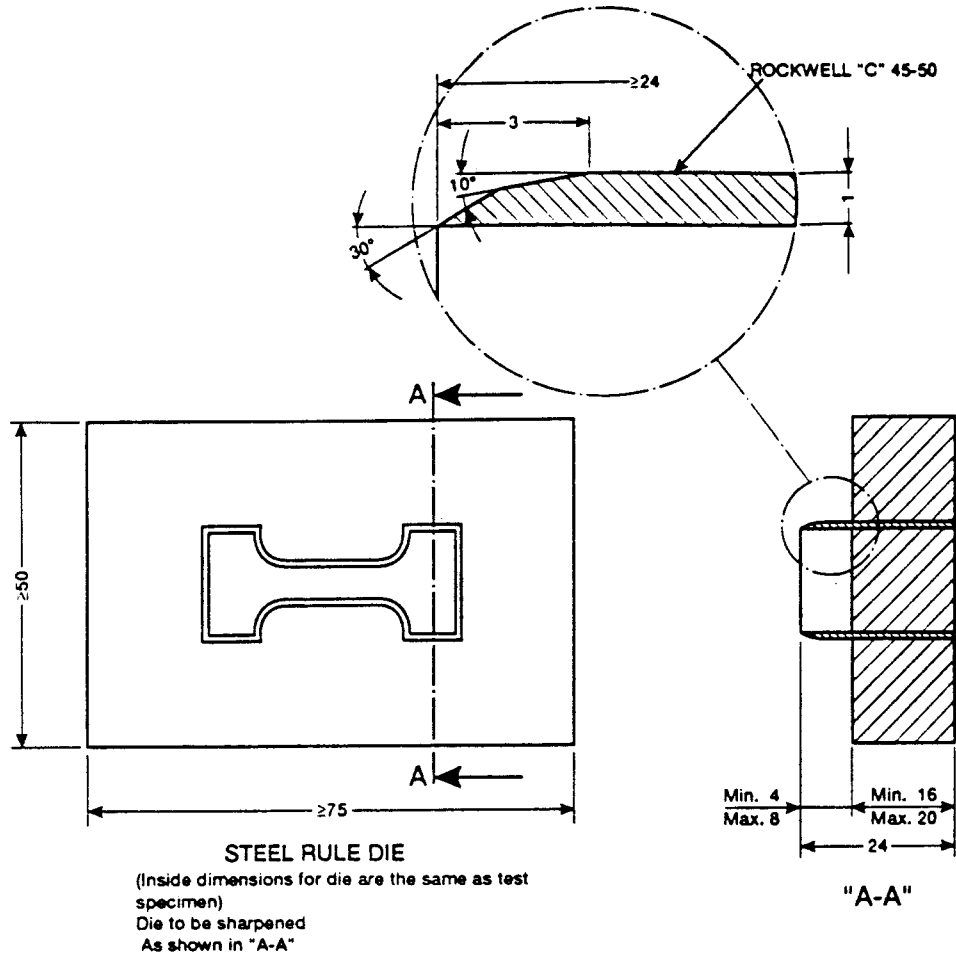

NOTE 1—All dimensions are in millimetres.
FIG. 1 Microtensile Die and Test Specimen

nearest 0.025 mm (0.001 in.) and the thickness to the nearest 0.0025 mm (0.0001 in.) for specimens less than 2.5 mm (0.1 in.) thick, or to the nearest 0.025 mm (0.001 in.) for specimens 2.5 mm (0.1 in.) or greater in thickness.

10.3 Set the testing machine so that the distance between the grips is 22.00 ± 0.05 mm (0.866 ± 0.002 in.).

NOTE 5—This may easily be checked by the use of a 22.86-mm

(0.900-in.) gage block or a pair of inside calipers.

10.4 Place the specimen in the grips of the testing machine with the inside edge of each tab visible at the edge of the grip, taking care to align the long axis of the specimen and the grip with an imaginary line joining the points of attachment of the grips to the machine. Tighten the grips evenly and firmly to the degree necessary to prevent slippage of the specimen during

the test, but not to the point where the specimen would be crushed.

10.5 Set the speed control at the speed desired (8.2) and start the machine.

10.6 Record the load at the yield point (if one exists), the maximum load carried by the specimen during the test, the load at rupture, and the elongation (extension between grips) at the moment of rupture.

11. Calculation

11.1 *Yield Strength, Tensile Strength, and Tensile Strength at Break*—Calculate the yield strength, tensile strength, and tensile strength at break in accordance with Test Method D 638.

11.2 *Percentage Elongation at Break*—Calculate the percentage elongation at break by dividing the elongation (extension) at the moment of rupture of the specimen by the original distance between tabs 22.250 ± 0.051 mm (0.876 ± 0.002 in.), and multiplying by one hundred. Report the percentage elongation to two significant figures.

11.3 *Percentage Elongation at the Yield Point*—Calculate the percentage elongation at the yield point, if desired, by dividing the elongation (extension) at the yield point by the original distance between tabs 22.250 ± 0.051 mm (0.876 ± 0.002 in.), and multiplying by one hundred.

11.4 Calculate the “average value” and standard deviation for each property in accordance with Test Method D 638.

12. Report

12.1 Results of this test method shall not be reported as having been obtained in accordance with Test Methods D 882 or Test Method D 638 regardless of any modifications that might be made to simulate those testing parameters.

12.2 Report the following information:

12.2.1 Complete identification of the material tested, including type, source, manufacturer’s code numbers, form, principal dimensions, previous history, and other pertinent information,

12.2.2 Method of preparing test specimens,

12.2.3 Specimen thickness,

12.2.4 Conditioning procedure used,

12.2.5 Atmospheric conditions in test room,

12.2.6 Number of specimens tested,

12.2.7 Speed of testing,

12.2.8 Yield strength (if any), average value, and standard deviation,

12.2.9 Tensile strength, average value, and standard deviation,

12.2.10 Tensile strength at break, average value, and standard deviation,

12.2.11 Percentage elongation at break, average value, and standard deviation,

12.2.12 Percentage elongation at the yield point, average value, and standard deviation (if desired),

12.2.13 Date of test, and

12.2.14 Date of test method.

13. Precision and Bias

13.1 *Precision*—Table 1 and Table 2 are based on a round robin conducted in 1995 in accordance with Practice E 691, involving two materials tested by seven laboratories. Polybutylene specimens were die cut from tubing. Polyamide(imide) specimens were injection molded. For each material, all of the specimens were prepared at one source. Each test result is the average of five individual determinations, each on a previously untested specimen. Each laboratory obtained two test results for each material.

NOTE 6—**Caution:** The following explanations of r and R (13.1.1-13.1.1.3) are only intended to present a meaningful way of considering the approximate precision of this test method. The data in Table 1 and Table 2 should not be applied rigorously to the acceptance or rejection of material, as those data are specific to the round robin and may not be representative of other lots, conditions, materials, or laboratories. Users of this test method should apply the principles outlined in Practice E 691 to generate data specific to their laboratory and materials, or between specific laboratories. The principles of 13.1.1-13.1.1.3 would then be valid for such data.

13.1.1 *Concept of r and R* —If S_r and S_R have been calculated from a large enough body of data, and for test results that were averages from testing five specimens:

13.1.1.1 *Repeatability Limit, r* (Comparing two test results for the same material, obtained by the same operator using the same equipment on the same day)—The two test results should be judged not equivalent if they differ by more than the r value for that material.

13.1.1.2 *Reproducibility Limit, R* (Comparing two test results for the same material, obtained by different operators using different equipment in different laboratories)—The two test results should be judged not equivalent if they differ by more than the R value for that material.

13.1.1.3 Any judgment in accordance with 13.1.1.1 or 13.1.1.2 would have an approximate 95 % (0.95) probability of being correct.

13.2 *Bias*—There are no recognized standards by which to estimate the bias of this test method.

14. Keywords

14.1 microtensile; plastics test method; tensile properties

TABLE 2 Elongation at Break for Seven Laboratories and Two Materials, %

Material	Test Speed, mm/min	Average	S_r^A	S_R^B	r^C	R^D
Polyamide(imide)	1.3	15.7	0.96	2.40	2.70	6.73
Polybutylene	12.7	196	8.94	16.1	25.0	45.2

^A S_r is the within-laboratory standard deviation for the indicated material. It is obtained by pooling the within-laboratory standard deviations of the test results from all of the participating laboratories:

$$S_r = [[(S_1)^2 + (S_2)^2 + \dots + (S_n)^2]/n]^{1/2}. \quad (2)$$

^B S_R is the between-laboratories reproducibility, expressed as a standard deviation, for the indicated material.

^C r is the within-laboratory repeatability limit, $r = 2.8 \times S_r$.

^D R is the between-laboratory reproducibility limit, $R = 2.8 \times S_R$.



ASTM International takes no position respecting the validity of any patent rights asserted in connection with any item mentioned in this standard. Users of this standard are expressly advised that determination of the validity of any such patent rights, and the risk of infringement of such rights, are entirely their own responsibility.

This standard is subject to revision at any time by the responsible technical committee and must be reviewed every five years and if not revised, either reapproved or withdrawn. Your comments are invited either for revision of this standard or for additional standards and should be addressed to ASTM International Headquarters. Your comments will receive careful consideration at a meeting of the responsible technical committee, which you may attend. If you feel that your comments have not received a fair hearing you should make your views known to the ASTM Committee on Standards, at the address shown below.

This standard is copyrighted by ASTM International, 100 Barr Harbor Drive, PO Box C700, West Conshohocken, PA 19428-2959, United States. Individual reprints (single or multiple copies) of this standard may be obtained by contacting ASTM at the above address or at 610-832-9585 (phone), 610-832-9555 (fax), or service@astm.org (e-mail); or through the ASTM website (www.astm.org).