



Designation: D 1790 – 9902

An American National Standard

## Standard Test Method for Brittleness Temperature of Plastic Sheeting by Impact <sup>1</sup>

This standard is issued under the fixed designation D 1790; the number immediately following the designation indicates the year of original adoption or, in the case of revision, the year of last revision. A number in parentheses indicates the year of last reapproval. A superscript epsilon ( $\epsilon$ ) indicates an editorial change since the last revision or reapproval.

### 1. Scope\*

1.1 This test method covers the determination of that temperature at which plastic sheeting 1.00 mm (0.040 in.) or less in thickness exhibits a brittle failure under specified impact conditions.

1.2 The values stated in SI units are to be regarded as the standard. The values given in parentheses are for information only.

NOTE 1—This test method was developed jointly with the Society of the Plastics Industry, primarily for use with plasticized vinyl sheetings. Its applicability to other plastic sheetings must be verified by the user.

1.3 *This standard does not purport to address the safety concerns, if any, associated with its use. It is the responsibility of the user of this standard to establish appropriate safety and health practices and determine the applicability of regulatory limitations prior to use.* Specific precautionary statements are given in Note 4.

NOTE 2—This test method is similar to ISO 8570-1991 in title only. The technical content is significantly different.

### 2. Referenced Documents

#### 2.1 ASTM Standards:

<sup>1</sup> This test method is under the jurisdiction of ASTM Committee D-20 on Plastics and is the direct responsibility of Subcommittee D20.30 on Thermal Properties (Section D20.30.07).

Current edition approved Nov. 10, 1999; 2002. Published February 2000; May 2002. Originally published as D 1790 – 60 T. Last previous edition D 1790 – 94<sup>ε1</sup>. D 1790 – 99.

\*A Summary of Changes section appears at the end of this standard.

- D 618 Practice for Conditioning Plastics and Electrical Insulating Materials for Testing<sup>2</sup>
- D 883 Terminology Relating to Plastics<sup>2</sup>
- E 691 Practice for Conducting an Interlaboratory Study to Determine the Precision of a Test Method<sup>3</sup>
- 2.2 ISO Standard:
  - ISO 8570-1991 Plastics—Film and Sheeting—Determination of Cold-Crack Temperature<sup>4</sup>

### 3. Terminology

#### 3.1 Definitions:

3.1.1 *brittleness temperature,  $T_b$* —that temperature, derived statistically, where 80 % of the specimens would probably pass 95 % of the time when a stated minimum number are tested by this test method. The 80 %-passing value may be determined by plotting the data on probability graph paper, as described in 9.1.

3.1.2 *General*—Definitions of terms applying to this test method appear in Terminology D 883.

### 4. Significance and Use

4.1 Data obtained by this test method may be used to predict the behavior of plastic sheeting at low temperatures only if the conditions of deformation are similar to those specified in this test method. This test method is useful for specification testing and for comparative purposes, but does not necessarily measure the lowest temperature at which the plastic sheeting may be used.

4.2 It has been demonstrated that on calendered sheeting the brittleness temperature is sensitive to the direction of fold. It has also been demonstrated that the brittleness temperature is sensitive to the direction of sampling. Therefore, it is imperative that the procedure for taking specimens and folding be followed explicitly.

### 5. Apparatus

5.1 *Cold Conditioning Chamber*, at least 450 by 450 by 450 mm (18 by 18 by 18 in.). ~~Suitable means~~ Means (automatic or manual) shall be provided for controlling the temperature of the chamber to within  $\pm 42^\circ\text{C}$  of the desired value.

5.2 *Impact Tester*<sup>5</sup> shown in Fig. 1 shall be constructed of cold-rolled steel except for the bolts, screws, and rubber stopper. All structural parts (that is, base, anvil, arm, arm supports, and shaft) may be chromium plated. The arm, including the rubber stopper and bolt, shall weigh  $3.09\text{ kg} \pm 28\text{ g}$  ( $6\text{ lb } 13 \pm 1\text{ oz}$ ).

5.3 *Die*,  $50.8 \pm 0.4\text{ mm}$  by  $146.1 \pm 0.4\text{ mm}$  ( $2 \pm \frac{1}{64}\text{ in.}$  by  $5\frac{3}{4} \pm \frac{1}{64}\text{ in.}$ ) to cut the test specimens from the sample.

5.4 *Stapler*, desk-type, with a stop mounted on the base exactly 12.7 mm ( $\frac{1}{2}\text{ in.}$ ) back of the center of the groove that turns the staple.

5.5 *Index Card Stock*, 50 by 127 mm (2 by 5 in.).

<sup>2</sup> Annual Book of ASTM Standards, Vol 08.01.

<sup>3</sup> Annual Book of ASTM Standards, Vol 14.02.

<sup>4</sup> Available from American National Standards Institute, 11 W. 42nd St., 13th Floor, New York, NY 10036.

<sup>5</sup> A suitable tester is available from the United States Testing Co., 1415 Park Ave., Hoboken, NJ.

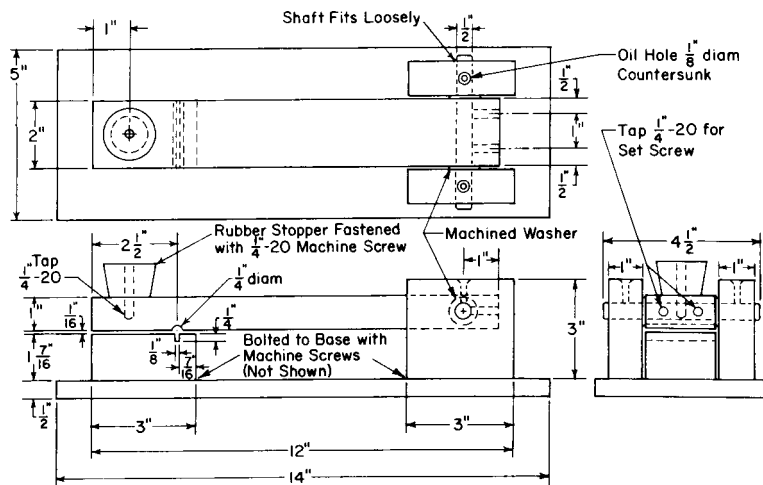

Metric Equivalents

in.	1/8	1/4	7/16	1/2	1	2 1/2	3	4 1/2	12	14
mm	3.2	6.4	11.1	12.7	25.4	64	76	114	305	356

FIG. 1 Brittleness Temperature Impact Testing Machine

## 6. Test Specimens

6.1 The test specimens shall be cut with the die. The length of the test specimen shall be parallel to the transverse direction of the sheeting. The 50-mm (2-in.) ends of each specimen shall be so collected that a gradual, closed loop is formed at room temperatures. The collected ends of the specimen and one end of the 50 by 127-mm (2 by 5-in.) card shall be matched exactly with the body of the loop lying on the card. Two staples shall be crimped through the matched ends of the specimen and card. These staples shall be 13 mm (½ in.) from, and parallel to, the 50-mm (2-in.) end of the stack.

6.2 Since it has been demonstrated that this test is sensitive to the direction of fold on calendered sheeting, it is necessary to stipulate that all specimens be folded in the same direction. It is recommended that, for materials with no grain, the specimen be folded so that the surface last in contact with the roll shall be inside the loop following the inherent shape of the specimen; grained materials are to be tested with the grained surface on the inside of the loop.

## 7. Conditioning

7.1 *Conditioning*—Condition the test specimens at  $23 \pm 2^\circ\text{C}$  ( $73.4 \pm 3.6^\circ\text{F}$ ) and  $50 \pm 5\%$  relative humidity for not less than 40 h prior to test in accordance with Procedure A of Practice D 618, for those tests where conditioning is required. In cases of disagreement, the tolerances shall be  $\pm 1^\circ\text{C}$  ( $\pm 1.8^\circ\text{F}$ ) and  $\pm 2\%$  relative humidity.

7.2 *Test Conditions*—Conduct tests in the standard laboratory environment of  $23 \pm 2^\circ\text{C}$  ( $73.4 \pm 3.6^\circ\text{F}$ ) and  $50 \pm 5\%$  relative humidity, unless otherwise specified in the test methods or in this test method. In cases of disagreements, the tolerances shall be  $\pm 1^\circ\text{C}$  ( $\pm 1.8^\circ\text{F}$ ) and  $\pm 2\%$  relative humidity.

## 8. Procedure

8.1 Place the impact tester, with its base horizontal, in the cold conditioning chamber at the desired testing temperature, for a conditioning period of 1 h. Expose the specimens to the test temperature for  $15 \pm 5$  min.

8.2 Place each of ten mounted test specimens individually on the anvil with the crimped ends of the staples on the back of the card fitted into the groove in the anvil. Handle the card, not the sample. Locate the bent loop of the sheeting on the anvil with the loop centered on the anvil and facing away from the pivotal end of the impact arm.

8.3 Allow the impact arm to fall free from a position within  $5^\circ$  perpendicular to the base onto the bent loop. Repeat until each of the ten conditioned specimens has been tested.

8.4 Remove the specimens and examine for failure. Partial fracture shall be construed as failure as well as complete division into two or more pieces.

8.5 Adjust the temperature of the cold conditioning chamber and condition a second group of ten specimens for  $15 \pm 5$  min at a suitable temperature, as indicated by the results of testing the first group of ten specimens. Repeat the testing procedure and examination.

8.6 When using the standard graphic method to determine the 80 %-passing temperature, it is necessary to repeat this procedure of testing ten specimens at a series of temperatures differing by uniform increments of  $5^\circ\text{C}$ . When using the probability graph paper in 9.1, it is not necessary to obtain the lowest no-failure temperatures, at which no failure is obtained, or the highest failure temperature.

8.7 When testing for conformance to a specification, it shall be satisfactory to accept materials on the basis of testing a minimum of ten test specimens at the specified temperature. Not more than 20 % of the specified number of test specimens shall fail at the specified temperature.

## 9. Calculation

9.1 *Graphic Method*—Plot the data on probability graph paper with the temperature on the linear scale and the percentage failure on the probability scale. Select the temperature scale so that it represents a minimum of two divisions per degree Celsius. Draw a straight line through a minimum of four points, two above and two below the 50 % point. The temperature indicated at the intersection of the data line with the 20 % failure line shall be reported as  $T_b$ , the 80 % passing temperature (20 % failure temperature).

## 10. Report

10.1 Report the following information:

10.1.1 Complete identification of the material tested, including type, source, manufacturer's code designation, form, and previous history,

10.1.2 Eighty percent passing temperature, to the nearest degree Celsius,

10.1.3 Thickness of test specimen,

10.1.4 Direction of fold,

10.1.5 Conditioning procedure, and

10.1.6 Date of test.

10.2 For routine acceptance testing, report the following instead of 10.1.1, and 10.1.2:

10.2.1 Number of specimens tested,

10.2.2 Temperature of test, and

### 10.2.3 Number of failures.

## 11. Precision and Bias

11.1 Table 1 is based on a round robin conducted in 1991 in accordance with Practice E 691, involving three materials tested by seven laboratories. For each material, all of the samples were prepared at one source, but the individual specimens were prepared at the laboratories that tested them. The test result for each material was based on a minimum of four trials, performed under varying conditions, involving ten specimens in each trial. Each laboratory obtained two test results for each material.

NOTE 3—Material Number 3 (SP-61737 Lot 30) was tested successfully by only three of the seven participating labs due to equipment limitations.

NOTE 4—**Caution:** The following explanations of  $r$  and  $R$  (11.2 through 11.2.3) are only intended to present a meaningful way of considering the approximate precision of this method. The data in Table 1 should not be rigorously applied to acceptance or rejection of material, as those data are specific to the round robin and may not be representative of other lots, conditions, materials, or laboratories. Users of this test method should apply the principles outlined in Practice E 691 to generate data specific to their laboratory and materials, or between specific laboratories. The principles of 11.2 through 11.2.3 would then be valid for such data.

11.2 *Concept of  $r$  and  $R$* —If  $S_r$  and  $S_t$  have been calculated from a large enough body of data, and for test results that were averages from testing 40 specimens (four trials involving ten specimens in each trial):

11.2.1 *Repeatability Limit,  $r$* —(Comparing two test results for the same material, obtained by the same operator using the same equipment on the same day.) The two test results should be judged not equivalent if they differ by more than the “ $r$ ” value for that material.

11.2.2 *Reproducibility Limit,  $R$* —(Comparing two test results for the same material, obtained by two different operators using different equipment in different laboratories.) The two test results should be judged not equivalent if they differ by more than the “ $R$ ” value for that material.

11.2.3 Any judgment in accordance with 11.2.1 or 11.2.2 would have an approximate 95 % probability of being correct.

11.3 There are no recognized standards by which to estimate the bias of this test method.

## 12. Keywords

12.1 brittleness temperature; cold-crack temperature; impact; plastic sheeting

## SUMMARY OF CHANGES

This section identifies the location of selected changes to this test method. For the convenience of the user, Committee D-20 has highlighted those changes that may impact the use of this test method. This section may also include descriptions of the changes or reasons for the changes, or both.

D 1790-9402:

(I) The definition of *brittleness temperature* in 3.1.1 was revised, an ISO equivalency statement was added, and the precision and bias was updated. Revised 5.1.

D 1790-99:

(I) Included a Summary of Changes section.

D 1790-94<sup>e1</sup>:

**TABLE 1 Statistical Assessment of Brittleness Temperature Round-Robin Results**

Values Expressed in °C							
Number	Material	Description	Average	$S_r^A$	$S_R^B$	$r^C$	$R^D$
1	HN-81414	Lot 3 Squirrel Grey 0.013 in. (0.33 mm)	-16.2	0.62	2.36	1.74	6.61
2	HC-41310	Lot 2 Special Tan 0.014 in. (0.36 mm)	-18.3	0.80	2.88	2.24	8.10
3	SP-61737	Lot 30 Blue 0.020 in. (0.51 mm)	-39.2	0.73	3.71	2.04	10.4

<sup>A</sup>  $S_r$  = within-laboratory standard deviation.

<sup>B</sup>  $S_R$  = between-laboratory standard deviation.

<sup>C</sup>  $r$  = within-laboratory repeatability limit =  $2.8^* S_r$ .

<sup>D</sup>  $R$  = between-laboratory reproducibility limit =  $2.8^* S_R$ .

(I) Footnote 5 and 10.1.2 were corrected editorially in August 1995.

~~D 1790–994:~~

~~(I) Included a Summary~~ The definition of ~~Changes section~~ *brittleness temperature* in 3.1.1 was revised, an ISO equivalency statement was added, and the precision and bias was updated.

*ASTM International takes no position respecting the validity of any patent rights asserted in connection with any item mentioned in this standard. Users of this standard are expressly advised that determination of the validity of any such patent rights, and the risk of infringement of such rights, are entirely their own responsibility.*

*This standard is subject to revision at any time by the responsible technical committee and must be reviewed every five years and if not revised, either reapproved or withdrawn. Your comments are invited either for revision of this standard or for additional standards and should be addressed to ASTM International Headquarters. Your comments will receive careful consideration at a meeting of the responsible technical committee, which you may attend. If you feel that your comments have not received a fair hearing you should make your views known to the ASTM Committee on Standards, at the address shown below.*

*This standard is copyrighted by ASTM International, 100 Barr Harbor Drive, PO Box C700, West Conshohocken, PA 19428-2959, United States. Individual reprints (single or multiple copies) of this standard may be obtained by contacting ASTM at the above address or at 610-832-9585 (phone), 610-832-9555 (fax), or [service@astm.org](mailto:service@astm.org) (e-mail); or through the ASTM website ([www.astm.org](http://www.astm.org)).*