



Designation: **D 256 – 034**

# Standard Test Methods for Determining the Izod Pendulum Impact Resistance of Plastics<sup>1</sup>

This standard is issued under the fixed designation D 256; the number immediately following the designation indicates the year of original adoption or, in the case of revision, the year of last revision. A number in parentheses indicates the year of last reapproval. A superscript epsilon ( $\epsilon$ ) indicates an editorial change since the last revision or reapproval.

## 1. Scope\*

1.1 These test methods cover the determination of the resistance of plastics to “standardized” (see Note 1) pendulum-type hammers, mounted in “standardized” machines, in breaking standard specimens with one pendulum swing (see Note 2). The standard tests for these test methods require specimens made with a milled notch (see Note 3). In Test Methods A, C, and D, the notch produces a stress concentration that increases the probability of a brittle, rather than a ductile, fracture. In Test Method E, the impact resistance is obtained breakage by flexural shock as indicated by the energy extracted from by reversing the notched specimen 180° in the clamping vise. The results of all test methods are reported in terms of energy absorbed per unit of specimen width or per unit of cross-sectional area under the notch. (See Note 4.)

NOTE 1—The machines with their pendulum-type hammers have been “standardized” in that they must comply with certain requirements, including a fixed height of hammer fall that results in a substantially fixed velocity of the hammer at the moment of impact. However, hammers of different initial energies (produced by varying their effective weights) are recommended for use with specimens of different impact resistance. Moreover, manufacturers of the equipment are permitted to use different lengths and constructions of pendulums with possible differences in pendulum rigidities resulting. (See Section 5.) Be aware that other differences in machine design may exist. The specimens are “standardized” in that they are required to have one fixed length, one fixed depth, and one particular design of milled notch. The width of the specimens is permitted to vary between limits.

NOTE 2—Results generated using pendulums that utilize a load cell to record the impact force and thus impact energy, may not be equivalent to results that are generated using manually or digitally encoded testers that measure the energy remaining in the pendulum after impact.

NOTE 3—The notch in the Izod specimen serves to concentrate the stress, minimize plastic deformation, and direct the fracture to the part of the specimen behind the notch. Scatter in energy-to-break is thus reduced. However, because of differences in the elastic and viscoelastic properties of plastics, response to a given notch varies among materials. A measure of a plastic’s “notch sensitivity” may be obtained with Test Method D by comparing the energies to break specimens having different radii at the base of the notch.

NOTE 4—Caution must be exercised in interpreting the results of these standard test methods. The following testing parameters may affect test results significantly:

- Method of fabrication, including but not limited to processing technology, molding conditions, mold design, and thermal treatments;
- Method of notching;
- Speed of notching tool;
- Design of notching apparatus;
- Quality of the notch;
- Time between notching and test;
- Test specimen thickness,
- Test specimen width under notch, and
- Environmental conditioning.

1.2 The values stated in SI units are to be regarded as the standard. The values given in brackets are for information only.

1.3 *This standard does not purport to address all of the safety concerns, if any, associated with its use. It is the responsibility of the user of this standard to establish appropriate safety and health practices and determine the applicability of regulatory limitations prior to use.*

NOTE 5—These test methods resemble ISO 180:1993 in regard to title only. The contents are significantly different.

## 2. Referenced Documents

### 2.1 *ASTM Standards:*<sup>2</sup>

D 618 Practice for Conditioning Plastics for Testing

<sup>1</sup> These test methods are under the jurisdiction of ASTM Committee D20 on Plastics and are the direct responsibility of Subcommittee D20.10 on Mechanical Properties

Current edition approved December 1, 2003. Published January 2004. Originally approved in 1926. Last previous edition approved in 2002 as D 256 - 02 $\epsilon$ 3.

<sup>2</sup> For referenced ASTM standards, visit the ASTM website, [www.astm.org](http://www.astm.org), or contact ASTM Customer Service at [service@astm.org](mailto:service@astm.org). For *Annual Book of ASTM Standards* volume information, refer to the standard’s Document Summary page on the ASTM website.

\*A Summary of Changes section appears at the end of this standard.

D 883 Terminology Relating to Plastics

D 3641 Practice for Injection Molding Test Specimens of Thermoplastics Molding Extrusion Materials

D 4000 Classification System for Specifying Plastic Materials

D 4066 Classification System for Nylon Injection and Extrusion Materials

D 4812 Test Methods for Unnotched Cantilever Beam Impact Resistance of Plastics

D 5947 Test Methods for Physical Dimensions of Solid Plastic Specimens

E 691 Practice for Conducting an Interlaboratory Test Program to Determine the Precision of Test Methods

2.2 *ISO Standard:*

ISO 180:1993 Plastics—Determination of Izod Impact Strength of Rigid Materials<sup>3</sup>

### 3. Terminology

3.1 *Definitions*— For definitions related to plastics see Terminology D 883.

3.2 *Definitions of Terms Specific to This Standard:*

3.2.1 *cantilever*—a projecting beam clamped at only one end.

3.2.2 *notch sensitivity*—a measure of the variation of impact energy as a function of notch radius.

### 4. Types of Tests

4.1 Four similar methods are presented in these test methods. (See Note 6.) All test methods use the same testing machine and specimen dimensions. There is no known means for correlating the results from the different test methods.

NOTE 6—Test Method B for Charpy has been removed and is being revised under a new standard.

4.1.1 In Test Method A, the specimen is held as a vertical cantilever beam and is broken by a single swing of the pendulum. The line of initial contact is at a fixed distance from the specimen clamp and from the centerline of the notch and on the same face as the notch.

4.1.2 Test Method C is similar to Test Method A, except for the addition of a procedure for determining the energy expended in tossing a portion of the specimen. The value reported is called the “estimated net Izod impact resistance.” Test Method C is preferred over Test Method A for materials that have an Izod impact resistance of less than 27 J/m [0.5 ft-lbf/in.] under notch. (See Appendix X4 for optional units.) The differences between Test Methods A and C become unimportant for materials that have an Izod impact resistance higher than this value.

4.1.3 Test Method D provides a measure of the notch sensitivity of a material. The stress-concentration at the notch increases with decreasing notch radius.

4.1.3.1 For a given system, greater stress concentration results in higher localized rates-of-strain. Since the effect of strain-rate on energy-to-break varies among materials, a measure of this effect may be obtained by testing specimens with different notch radii. In the Izod-type test it has been demonstrated that the function, energy-to-break versus notch radius, is reasonably linear from a radius of 0.03 to 2.5 mm [0.001 to 0.100 in.], provided that all specimens have the same type of break. (See 5.8 and 22.1.)

4.1.3.2 For the purpose of this test, the slope,  $b$  (see 22.1), of the line between radii of 0.25 and 1.0 mm [0.010 and 0.040 in.] is used, unless tests with the 1.0-mm radius give “non-break” results. In that case, 0.25 and 0.50-mm [0.010 and 0.020-in.] radii may be used. The effect of notch radius on the impact energy to break a specimen under the conditions of this test is measured by the value  $b$ . Materials with low values of  $b$ , whether high or low energy-to-break with the standard notch, are relatively insensitive to differences in notch radius; while the energy-to-break materials with high values of  $b$  is highly dependent on notch radius. The parameter  $b$  cannot be used in design calculations but may serve as a guide to the designer and in selection of materials.

4.2 Test Method E is similar to Test Method A, except that the specimen is reversed in the vise of the machine 180° to the usual striking position, such that the striker of the apparatus impacts the specimen on the face opposite the notch. (See Fig. 1, Fig. 2.) Test Method E is used to give an indication of the unnotched impact resistance of plastics; however, results obtained by the reversed notch method may not always agree with those obtained on a completely unnotched specimen. (See 28.1.)<sup>4,5</sup>

### 5. Significance and Use

5.1 Before proceeding with these test methods, reference should be made to the specification of the material being tested. Any test specimen preparation, conditioning, dimensions, and testing parameters covered in the materials specification shall take precedence over those mentioned in these test methods. If there is no material specification, then the default conditions apply.

5.2 The excess energy pendulum impact test indicates the energy to break standard test specimens of specified size under stipulated parameters of specimen mounting, notching, and pendulum velocity-at-impact.

5.3 The energy lost by the pendulum during the breakage of the specimen is the sum of the following:

5.3.1 Energy to initiate fracture of the specimen;

<sup>3</sup> Available from American National Standards Institute (ANSI), 25 W. 43rd St., 4th Floor, New York, NY 10036.

<sup>4</sup> Supporting data giving results of the interlaboratory tests are available from ASTM Headquarters. Request RR: D20-1021.

<sup>5</sup> Supporting data giving results of the interlaboratory tests are available from ASTM Headquarters. Request RR: D20-1026.

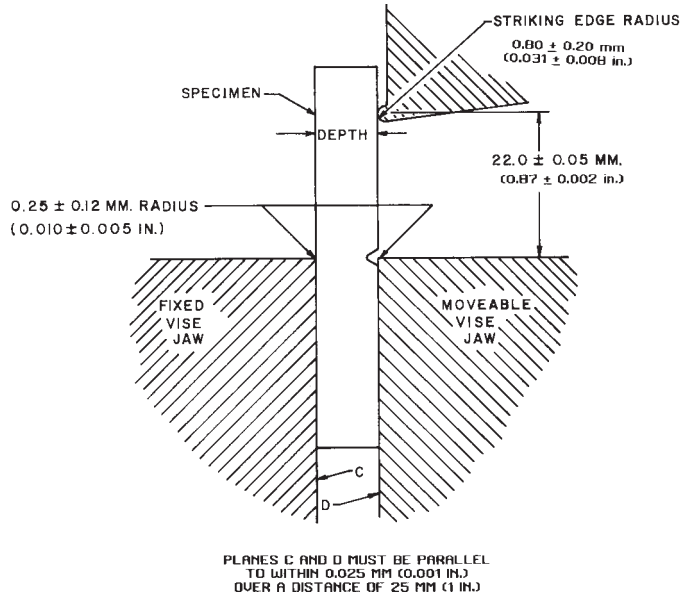

FIG. 1 Relationship of Vise, Specimen, and Striking Edge to Each Other for Izod Test Methods A and C

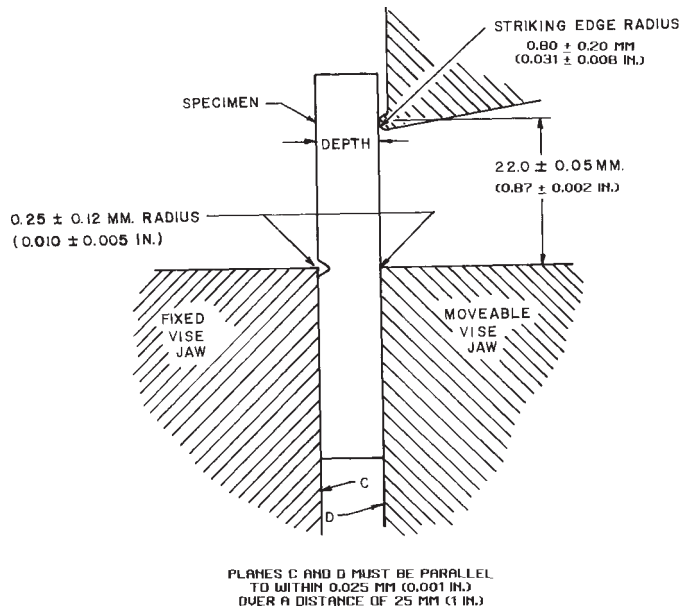

FIG. 2 Relationship of Vise, Specimen, and Striking Edge to Each Other for Test Method E

- 5.3.2 Energy to propagate the fracture across the specimen;
- 5.3.3 Energy to throw the free end (or ends) of the broken specimen (“toss correction”);
- 5.3.4 Energy to bend the specimen;
- 5.3.5 Energy to produce vibration in the pendulum arm;
- 5.3.6 Energy to produce vibration or horizontal movement of the machine frame or base;
- 5.3.7 Energy to overcome friction in the pendulum bearing and in the excess energy indicating mechanism, and to overcome windage (pendulum air drag);
- 5.3.8 Energy to indent or deform plastically the specimen at the line of impact; and
- 5.3.9 Energy to overcome the friction caused by the rubbing of the striker (or other part of the pendulum) over the face of the bent specimen.

5.4 For relatively brittle materials, for which fracture propagation energy is small in comparison with the fracture initiation energy, the indicated impact energy absorbed is, for all practical purposes, the sum of factors 5.3.1 and 5.3.3. The toss correction (see 5.3.3) may represent a very large fraction of the total energy absorbed when testing relatively dense and brittle materials. Test Method C shall be used for materials that have an Izod impact resistance of less than 27 J/m [0.5 ft·lbf/in.]. (See Appendix X4 for

optional units.) The toss correction obtained in Test Method C is only an approximation of the toss error, since the rotational and rectilinear velocities may not be the same during the re-toss of the specimen as for the original toss, and because stored stresses in the specimen may have been released as kinetic energy during the specimen fracture.

5.5 For tough, ductile, fiber filled, or cloth-laminated materials, the fracture propagation energy (see 5.3.2) may be large compared to the fracture initiation energy (see 5.3.1). When testing these materials, factors (see 5.3.2, 5.3.5, and 5.3.9) can become quite significant, even when the specimen is accurately machined and positioned and the machine is in good condition with adequate capacity. (See Note 7.) Bending (see 5.3.4) and indentation losses (see 5.3.8) may be appreciable when testing soft materials.

NOTE 7—Although the frame and base of the machine should be sufficiently rigid and massive to handle the energies of tough specimens without motion or excessive vibration, the design must ensure that the center of percussion be at the center of strike. Locating the striker precisely at the center of percussion reduces vibration of the pendulum arm when used with brittle specimens. However, some losses due to pendulum arm vibration, the amount varying with the design of the pendulum, will occur with tough specimens, even when the striker is properly positioned.

5.6 In a well-designed machine of sufficient rigidity and mass, the losses due to factors 5.3.6 and 5.3.7 should be very small. Vibrational losses (see 5.3.6) can be quite large when wide specimens of tough materials are tested in machines of insufficient mass, not securely fastened to a heavy base.

5.7 With some materials, a critical width of specimen may be found below which specimens will appear ductile, as evidenced by considerable drawing or necking down in the region behind the notch and by a relatively high-energy absorption, and above which they will appear brittle as evidenced by little or no drawing down or necking and by a relatively low-energy absorption. Since these methods permit a variation in the width of the specimens, and since the width dictates, for many materials, whether a brittle, low-energy break or a ductile, high energy break will occur, it is necessary that the width be stated in the specification covering that material and that the width be reported along with the impact resistance. In view of the preceding, one should not make comparisons between data from specimens having widths that differ by more than a few mils.

5.8 The type of failure for each specimen shall be recorded as one of the four categories listed as follows:

C	<i>Complete Break</i> —A break where the specimen separates into two or more pieces.
H	<i>Hinge Break</i> —An incomplete break, such that one part of the specimen cannot support itself above the horizontal when the other part is held vertically (less than 90° included angle).
P	<i>Partial Break</i> —An incomplete break that does not meet the definition for a hinge break but has fractured at least 90 % of the distance between the vertex of the notch and the opposite side.
NB	<i>Non-Break</i> —An incomplete break where the fracture extends less than 90 % of the distance between the vertex of the notch and the opposite side.

For tough materials, the pendulum may not have the energy necessary to complete the breaking of the extreme fibers and toss the broken piece or pieces. Results obtained from “non-break” specimens shall be considered a departure from standard and shall not be reported as a standard result. Impact resistance cannot be directly compared for any two materials that experience different types of failure as defined in the test method by this code. Averages reported must likewise be derived from specimens contained within a single failure category. This letter code shall suffix the reported impact identifying the types of failure associated with the reported value. If more than one type of failure is observed for a sample material, then the report will indicate the average impact resistance for each type of failure, followed by the percent of the specimens failing in that manner and suffixed by the letter code.

5.9 The value of the impact methods lies mainly in the areas of quality control and materials specification. If two groups of specimens of supposedly the same material show significantly different energy absorptions, types of breaks, critical widths, or critical temperatures, it may be assumed that they were made of different materials or were exposed to different processing or conditioning environments. The fact that a material shows twice the energy absorption of another under these conditions of test does not indicate that this same relationship will exist under another set of test conditions. The order of toughness may even be reversed under different testing conditions.

NOTE 8—A documented discrepancy exists between manual and digital impact testers, primarily with thermoset materials, including phenolics, having an impact value of less than 54 J/m [1 ft-lb/in.]. Comparing data on the same material, tested on both manual and digital impact testers, may show the data from the digital tester to be significantly lower than data from a manual tester. In such cases a correlation study may be necessary to properly define the true relationship between the instruments.

## TEST METHOD A—CANTILEVER BEAM TEST

### 6. Apparatus

6.1 The machine shall consist of a massive base on which is mounted a vise for holding the specimen and to which is connected, through a rigid frame and bearings, a pendulum-type hammer. (See 6.2.) The machine must also have a pendulum holding and releasing mechanism and a pointer and dial mechanism for indicating the excess energy remaining in the pendulum after breaking the specimen. Optionally, an electronic digital display or computer can be used in place of the dial and pointer to measure the

energy loss and indicate the breaking energy of the specimen.

6.2 A jig for positioning the specimen in the vise and graphs or tables to aid in the calculation of the correction for friction and windage also should be included. One type of machine is shown in Fig. 3. One design of specimen-positioning jig is illustrated in Fig. 4. Detailed requirements are given in subsequent paragraphs. General test methods for checking and calibrating the machine are given in Appendix X1. Additional instructions for adjusting a particular machine should be supplied by the manufacturer.

6.3 The pendulum shall consist of a single or multi-membered arm with a bearing on one end and a head, containing the striker, on the other. The arm must be sufficiently rigid to maintain the proper clearances and geometric relationships between the machine parts and the specimen and to minimize vibrational energy losses that are always included in the measured impact resistance. Both simple and compound pendulum designs may comply with this test method.

6.4 The striker of the pendulum shall be hardened steel and shall be a cylindrical surface having a radius of curvature of  $0.80 \pm 0.20$  mm [ $0.031 \pm 0.008$  in.] with its axis horizontal and perpendicular to the plane of swing of the pendulum. The line of contact of the striker shall be located at the center of percussion of the pendulum within  $\pm 2.54$  mm [ $\pm 0.100$  in.] (See Note 9.) Those portions of the pendulum adjacent to the cylindrical striking edge shall be recessed or inclined at a suitable angle so that there will be no chance for other than this cylindrical surface coming in contact with the specimen during the break.

NOTE 9—The distance from the axis of support to the center of percussion may be determined experimentally from the period of small amplitude oscillations of the pendulum by means of the following equation:

$$L = (g/4\pi^2)p^2$$

where:

$L$  = distance from the axis of support to the center of percussion, m or [ft],

$g$  = local gravitational acceleration (known to an accuracy of one part in one thousand), m/s<sup>2</sup> or [ft/s<sup>2</sup>],

$\pi$  = 3.1416 ( $4\pi^2 = 39.48$ ), and

$p$  = period, s, of a single complete swing (to and fro) determined by averaging at least 20 consecutive and uninterrupted swings. The angle of swing shall be less than 5° each side of center.

6.5 The position of the pendulum holding and releasing mechanism shall be such that the vertical height of fall of the striker shall be  $610 \pm 2$  mm [ $24.0 \pm 0.1$  in.]. This will produce a velocity of the striker at the moment of impact of approximately 3.5 m [11.4 ft]/s. (See Note 10.) The mechanism shall be so constructed and operated that it will release the pendulum without imparting acceleration or vibration to it.

NOTE 10—

$$V = (2gh)^{0.5}$$

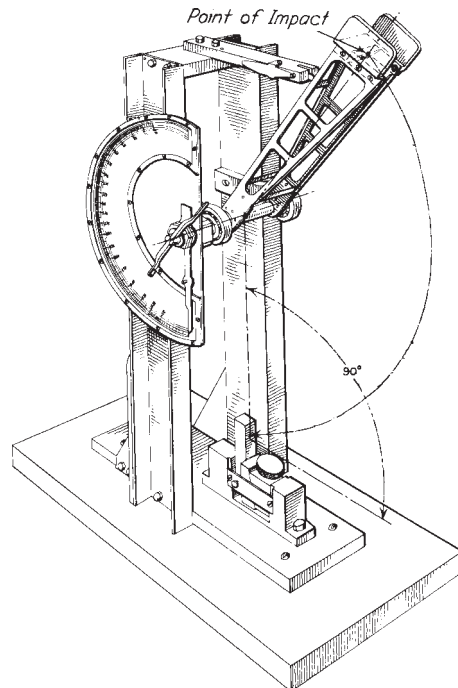

**FIG. 3 Cantilever Beam (Izod-Type) Impact Machine**



FIG. 4 Jig for Positioning Specimen for Clamping

where:

$V$  = velocity of the striker at the moment of impact (m/s),

$g$  = local gravitational acceleration ( $m/s^2$ ), and

$h$  = vertical height of fall of the striker (m).

This assumes no windage or friction.

6.6 The effective length of the pendulum shall be between 0.33 and 0.40 m [12.8 and 16.0 in.] so that the required elevation of the striker may be obtained by raising the pendulum to an angle between 60 and 30° above the horizontal.

6.7 The machine shall be provided with a basic pendulum capable of delivering an energy of  $2.7 \pm 0.14$  J [ $2.00 \pm 0.10$  ft-lbf]. This pendulum shall be used with all specimens that extract less than 85 % of this energy. Heavier pendulums shall be provided for specimens that require more energy to break. These may be separate interchangeable pendulums or one basic pendulum to which extra pairs of equal calibrated weights may be rigidly attached to opposite sides of the pendulum. It is imperative that the extra weights shall not significantly change the position of the center of percussion or the free-hanging rest point of the pendulum (that would consequently take the machine outside of the allowable calibration tolerances). A range of pendulums having energies from 2.7 to 21.7 J [2 to 16 ft-lbf] has been found to be sufficient for use with most plastic specimens and may be used with most machines. A series of pendulums such that each has twice the energy of the next will be found convenient. Each pendulum shall have an energy within  $\pm 0.5$  % of its nominal capacity.

6.8 A vise shall be provided for clamping the specimen rigidly in position so that the long axis of the specimen is vertical and at right angles to the top plane of the vise. (See Fig. 1.) This top plane shall bisect the angle of the notch with a tolerance of 0.12 mm [0.005 in.]. Correct positioning of the specimen is generally done with a jig furnished with the machine. The top edges of the fixed and moveable jaws shall have a radius of  $0.25 \pm 0.12$  mm [ $0.010 \pm 0.005$  in.]. For specimens whose thickness approaches the lower limiting value of 3.00 mm [0.118 in.], means shall be provided to prevent the lower half of the specimen from moving during the clamping or testing operations (see Fig. 4 and Note 11.)

NOTE 11—Some plastics are sensitive to clamping pressure; therefore, cooperating laboratories should agree upon some means of standardizing the clamping force. One method is using a torque wrench on the screw of the specimen vise. If the faces of the vise or specimen are not flat and parallel, a greater sensitivity to clamping pressure may be evident. See the calibration procedure in Appendix X2 for adjustment and correction instructions for faulty instruments.

6.9 When the pendulum is free hanging, the striking surface shall come within 0.2 % of scale of touching the front face of a standard specimen. During an actual swing this element shall make initial contact with the specimen on a line  $22.00 \pm 0.05$  mm [ $0.87 \pm 0.002$  in.] above the top surface of the vise.

6.10 Means shall be provided for determining energy remaining in the pendulum after breaking the specimen. This may consist of a pointer and dial mechanism which indicate the height of rise of the pendulum beyond the point of impact in terms of energy removed from that specific pendulum. Since the indicated remaining energy must be corrected for pendulum-bearing friction, pointer friction, pointer inertia, and pendulum windage, instructions for making these corrections are included in 10.3 and Annex A1 and Annex A2. Optionally, an electronic digital display or computer can be used in place of the dial and pointer to measure the energy loss and indicate the breaking energy of the specimen. If the electronic display does not automatically correct for windage and friction, it shall be incumbent for the operator to determine the energy loss manually. (See Note 12.)

NOTE 12—Many digital indicating systems automatically correct for windage and friction. The equipment manufacturer may be consulted for details concerning how this is performed, or if it is necessary to determine the means for manually calculating the energy loss due to windage and friction.

6.11 The vise, pendulum, and frame shall be sufficiently rigid to maintain correct alignment of the hammer and specimen, both at the moment of impact and during the propagation of the fracture, and to minimize energy losses due to vibration. The base shall be sufficiently massive that the impact will not cause it to move. The machine shall be so designed, constructed, and maintained that energy losses due to pendulum air drag (windage), friction in the pendulum bearings, and friction and inertia in the excess energy-indicating mechanism are held to a minimum.

6.12 A check of the calibration of an impact machine is difficult to make under dynamic conditions. The basic parameters are normally checked under static conditions; if the machine passes the static tests, then it is assumed to be accurate. The calibration procedure in Appendix X2 should be used to establish the accuracy of the equipment. However, for some machine designs it might be necessary to change the recommended method of obtaining the required calibration measurements. Other methods of performing the required checks may be substituted, provided that they can be shown to result in an equivalent accuracy. Appendix X1 also describes a dynamic test for checking certain features of the machine and specimen.

6.13 *Micrometers*—Apparatus for measurement of the width of the specimen shall comply with the requirements of Test Methods D 5947. Apparatus for the measurement of the depth of plastic material remaining in the specimen under the notch shall comply with requirements of Test Methods D 5947, provided however that the one anvil or presser foot shall be a tapered blade conforming to the dimensions given in Fig. 5. The opposing anvil or presser foot shall be flat and conforming to Test Methods D 5947.

## 7. Test Specimens

7.1 The test specimens shall conform to the dimensions and geometry of Fig. 6, except as modified in accordance with 7.2, 7.3, 7.4, and 7.5. To ensure the correct contour and conditions of the specified notch, all specimens shall be notched as directed in Section 8.

7.1.1 Studies have shown that, for some materials, the location of the notch on the specimen and the length of the impacted end may have a slight effect on the measured impact resistance. Therefore, unless otherwise specified, care must be taken to ensure that the specimen conforms to the dimensions shown in Fig. 6 and that it is positioned as shown in Fig. 1 or Fig. 2.

7.2 Molded specimens shall have a width between 3.0 and 12.7 mm [0.118 and 0.500 in.]. Use the specimen width as specified in the material specification or as agreed upon between the supplier and the customer. All specimens having one dimension less than 12.7 mm [0.500 in.] shall have the notch cut on the shorter side. Otherwise, all compression-molded specimens shall be notched on the side parallel to the direction of application of molding pressure. (Due to the draft of the mold, the notched surface and the opposite surface may not be parallel in molded specimens. Therefore, it is essential that the notched surface be machined parallel to its opposite surface within 0.025 mm [0.001 in.], removing a minimum of material in the process, so as to remain within the allowable tolerance for the specimen depth). (See Fig. 6.)

7.2.1 Extreme care must be used in handling specimens less than 6.35 mm [0.250 in.] wide. Such specimens must be accurately positioned and supported to prevent twist or lateral buckling during the test. Some materials, furthermore, are very sensitive to clamping pressure (see Note 11).

7.2.2 A critical investigation of the mechanics of impact testing has shown that tests made upon specimens under 6.35 mm [0.250 in.] wide absorb more energy due to crushing, bending, and twisting than do wider specimens. Therefore, specimens 6.35 mm [0.250 in.] or over in width are recommended. The responsibility for determining the minimum specimen width shall be the investigator's, with due reference to the specification for that material.

7.2.3 Material specification should be consulted for preferred molding conditions. The type of mold and molding machine used and the flow behavior in the mold cavity will influence the impact resistance obtained. A specimen taken from one end of a molded plaque may give different results than a specimen taken from the other end. Cooperating laboratories should therefore agree on standard molds conforming to the material specification. Practice D 3641 can be used as a guide for general molding tolerances, but refer to the material specification for specific molding conditions.

7.2.4 The impact resistance of a plastic material may be different if the notch is perpendicular to, rather than parallel to, the direction of molding. The same is true for specimens cut with or across the grain of an anisotropic sheet or plate.

7.3 For sheet materials, the specimens shall be cut from the sheet in both the lengthwise and crosswise directions unless otherwise specified. The width of the specimen shall be the thickness of the sheet if the sheet thickness is between 3.0 and 12.7 mm [0.118 and 0.500 in.]. Sheet material thicker than 12.7 mm shall be machined down to 12.7 mm. Specimens with a 12.7-mm square cross section may be tested either edgewise or flatwise as cut from the sheet. When specimens are tested flatwise, the notch shall be made on the machined surface if the specimen is machined on one face only. When the specimen is cut from a thick sheet, notation shall be made of the portion of the thickness of the sheet from which the specimen was cut, for example, center, top, or bottom surface.

7.4 The practice of cementing, bolting, clamping, or otherwise combining specimens of substandard width to form a composite test specimen is not recommended and should be avoided since test results may be seriously affected by interface effects or effects of solvents and cements on energy absorption of composite test specimens, or both. However, if Izod test data on such thin materials are required when no other means of preparing specimens are available, and if possible sources of error are recognized and acceptable, the following technique of preparing composites may be utilized.

# IZOD

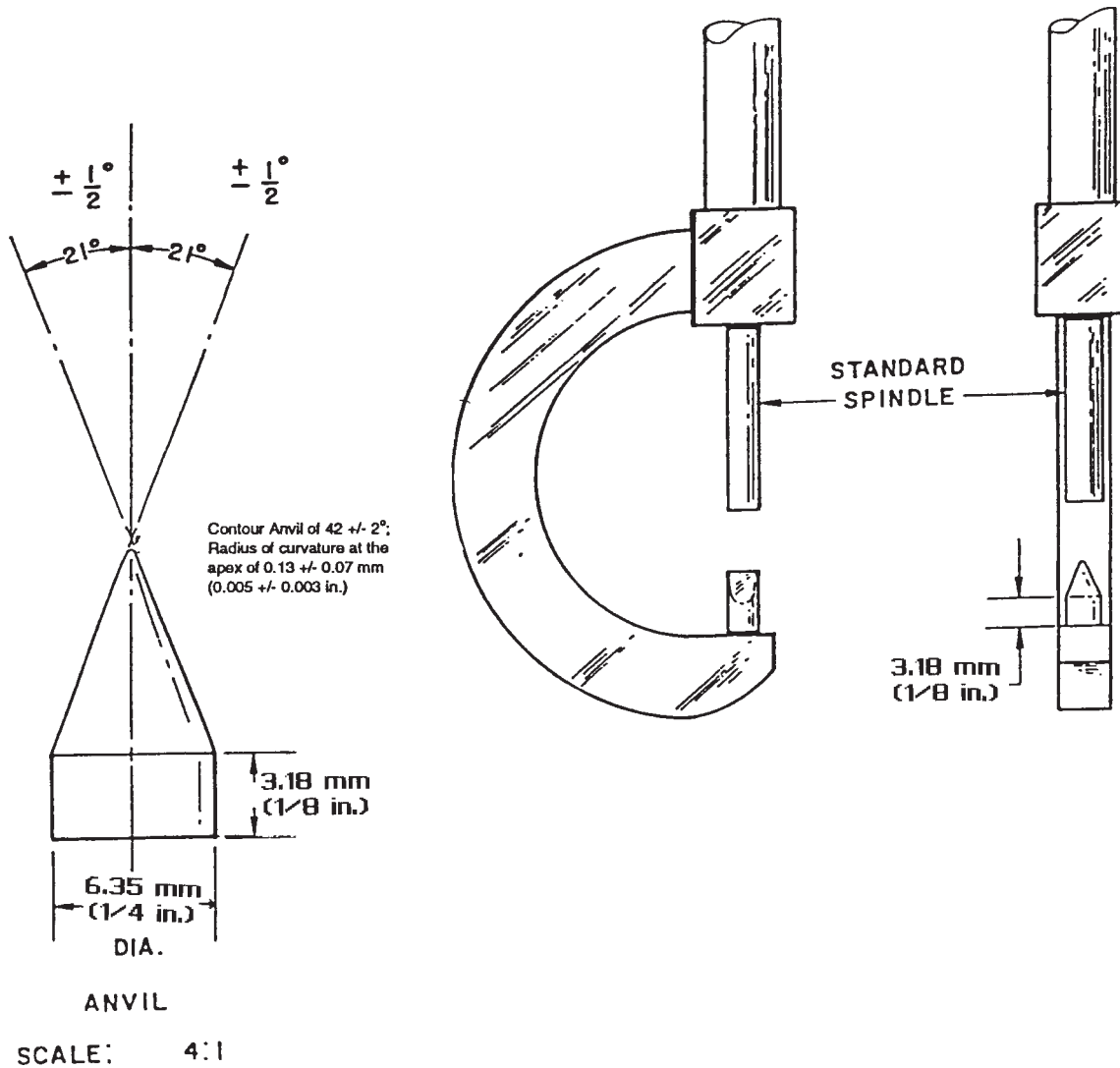

- NOTE 1—These views not to scale.
- NOTE 2—Micrometer to be satin-chrome finished with friction thimble.
- NOTE 3—Special anvil for micrometer caliper 0 to 25.4 mm range (50.8 mm frame) [0 to 1 in. range (2-in. frame)].
- NOTE 4—Anvil to be oriented with respect to frame as shown.
- NOTE 5—Anvil and spindle to have hardened surfaces.
- NOTE 6—Range: 0 to 25.4 mm [0 to 1 in. in thousandths of an inch].
- NOTE 7—Adjustment must be at zero when spindle and anvil are in contact.

**FIG. 5 Early (ca. 1970) Version of a Notch-Depth Micrometer**

7.4.1 The test specimen shall be a composite of individual thin specimens totaling 6.35 to 12.7 mm [0.250 to 0.500 in.] in width. Individual members of the composite shall be accurately aligned with each other and clamped, bolted, or cemented together. The composite shall be machined to proper dimensions and then notched. In all such cases the use of composite specimens shall be noted in the report of test results.

7.4.2 Care must be taken to select a solvent or adhesive that will not affect the impact resistance of the material under test. If solvents or solvent-containing adhesives are employed, a conditioning procedure shall be established to ensure complete removal of the solvent prior to test.

7.5 Each specimen shall be free of twist (see Note 13) and shall have mutually perpendicular pairs of plane parallel surfaces and free from scratches, pits, and sink marks. The specimens shall be checked for compliance with these requirements by visual observation against straightedges, squares, and flat plates, and by measuring with micrometer calipers. Any specimen showing observable or measurable departure from one or more of these requirements shall be rejected or machined to the proper size and shape before testing.

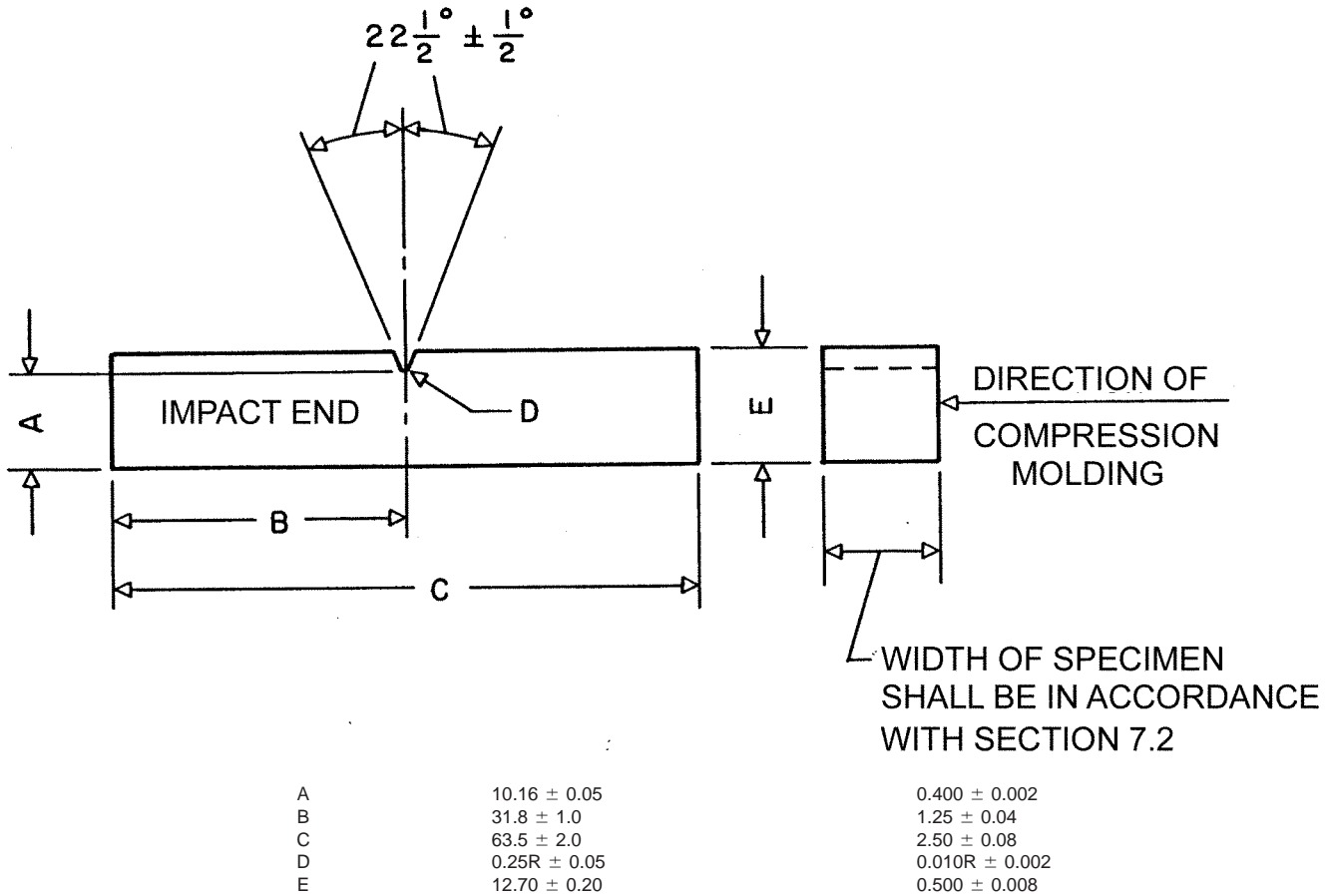

FIG. 6 Dimensions of Izod-Type Test Specimen

NOTE 13—A specimen that has a slight twist to its notched face of 0.05 mm [0.002 in.] at the point of contact with the pendulum striking edge will be likely to have a characteristic fracture surface with considerable greater fracture area than for a normal break. In this case the energy to break and toss the broken section may be considerably larger (20 to 30 %) than for a normal break. A tapered specimen may require more energy to bend it in the vise before fracture.

## 8. Notching Test Specimens

8.1 Notching shall be done on a milling machine, engine lathe, or other suitable machine tool. Both the feed speed and the cutter speed shall be constant throughout the notching operation (see Note 14). Provision for cooling the specimen with either a liquid or gas coolant is recommended. A single-tooth cutter shall be used for notching the specimen, unless notches of an equivalent quality can be produced with a multi-tooth cutter. Single-tooth cutters are preferred because of the ease of grinding the cutter to the specimen contour and because of the smoother cut on the specimen. The cutting edge shall be carefully ground and honed to ensure sharpness and freedom from nicks and burrs. Tools with no rake and a work relief angle of 15 to 20° have been found satisfactory.

NOTE 14—For some thermoplastics, cutter speeds from 53 to 150 m/min [175 to 490 ft/min] at a feed speed of 89 to 160 mm/min [3.5 to 6.3 in./min] without a water coolant or the same cutter speeds at a feed speed of from 36 to 160 mm/min [1.4 to 6.3 in./min] with water coolant produced suitable notches.

8.2 Specimens may be notched separately or in a group. However, in either case an unnotched backup or “dummy bar” shall be placed behind the last specimen in the sample holder to prevent distortion and chipping by the cutter as it exits from the last test specimen.

8.3 The profile of the cutting tooth or teeth shall be such as to produce a notch of the contour and depth in the test specimen as specified in Fig. 6 (see Note 15). The included angle of the notch shall be  $45 \pm 1^\circ$  with a radius of curvature at the apex of  $0.25 \pm 0.05$  mm [ $0.010 \pm 0.002$  in.]. The plane bisecting the notch angle shall be perpendicular to the face of the test specimen within  $2^\circ$ .

NOTE 15—There is evidence that notches in materials of widely varying physical dimensions may differ in contour even when using the same cutter. If the notch in the specimen should take the contour of the cutter, then the contour of the tip of the cutter may be checked instead of the notch in the specimen for single-tooth cutters. Under the same condition, multi-tooth cutters may be checked by measuring the contour of a strip of soft metal shim inserted between two specimens for notching.

8.4 The depth of the plastic material remaining in the specimen under the notch shall be  $10.16 \pm 0.05$  mm [ $0.400 \pm 0.002$  in.]. This dimension shall be measured with apparatus in accordance with 6.13. The tapered blade will be fitted to the notch. The specimen will be approximately vertical between the anvils. For specimens with a draft angle, position edge of the non-cavity (wider edge) surface centered on the micrometer's flat circular anvil.

8.5 Cutter speed and feed speed should be chosen appropriate for the material being tested since the quality of the notch may be adversely affected by thermal deformations and stresses induced during the cutting operation if proper conditions are not selected.<sup>6</sup> The notching parameters used shall not alter the physical state of the material such as by raising the temperature of a thermoplastic above its glass transition temperature. In general, high cutter speeds, slow feed rates, and lack of coolant induce more thermal damage than a slow cutter speed, fast feed speed, and the use of a coolant. Too high a feed speed/cutter speed ratio, however, may cause impacting and cracking of the specimen. The range of cutter speed/feed ratios possible to produce acceptable notches can be extended by the use of a suitable coolant. (See Note 16.) In the case of new types of plastics, it is necessary to study the effect of variations in the notching conditions. (See Note 17.)

NOTE 16—Water or compressed gas is a suitable coolant for many plastics.

NOTE 17—Embedded thermocouples, or another temperature measuring device, can be used to determine the temperature rise in the material near the apex of the notch during machining. Thermal stresses induced during the notching operation can be observed in transparent materials by viewing the specimen at low magnification between crossed polars in monochromatic light.

8.6 The specimen notch produced by each cutter will be examined, at a minimum, after every 500 notches. The notch in the specimen, made of the material to be tested, shall be inspected and verified. One procedure for the inspection and verification of the notch is presented in Appendix X1. Each type of material being notched must be inspected and verified at that time. If the angle or radius does not fall within the specified limits for materials of satisfactory machining characteristics, then the cutter shall be replaced with a newly sharpened and honed one. (See Note 18.)

NOTE 18—A carbide-tipped or industrial diamond-tipped notching cutter is recommended for longer service life.

## 9. Conditioning

9.1 *Conditioning*—Condition the test specimens at  $23 \pm 2^\circ\text{C}$  [ $73 \pm 3.6^\circ\text{F}$ ] and  $50 \pm 5\%$  relative humidity for not less than 40 h after notching and prior to testing in accordance with Procedure A of Practice D 618, unless it can be documented (between supplier and customer) that a shorter conditioning time is sufficient for a given material to reach equilibrium of impact resistance.

9.1.1 Note that for some hygroscopic materials, such as nylons, the material specifications (for example, Specification D 4066) call for testing “dry as-molded specimens.” Such requirements take precedence over the above routine preconditioning to 50 % relative humidity and require sealing the specimens in water vapor-impermeable containers as soon as molded and not removing them until ready for testing.

9.2 *Test Conditions*—Conduct tests in the standard laboratory atmosphere of  $23 \pm 2^\circ\text{C}$  [ $73 \pm 3.6^\circ\text{F}$ ] and  $50 \pm 5\%$  relative humidity, unless otherwise specified in the material specification or by customer requirements. In cases of disagreement, the tolerances shall be  $\pm 1^\circ\text{C}$  [ $\pm 1.8^\circ\text{F}$ ] and  $\pm 2\%$  relative humidity.

## 10. Procedure

10.1 At least five and preferably ten or more individual determinations of impact resistance must be made on each sample to be tested under the conditions prescribed in Section 9. Each group shall consist of specimens with the same nominal width ( $\pm 0.13$  mm [ $\pm 0.005$  in.]). In the case of specimens cut from sheets that are suspected of being anisotropic, prepare and test specimens from each principal direction (lengthwise and crosswise to the direction of anisotropy).

10.2 Estimate the breaking energy for the specimen and select a pendulum of suitable energy. Use the lightest standard pendulum that is expected to break each specimen in the group with a loss of not more than 85 % of its energy (see Note 19). Check the machine with the proper pendulum in place for conformity with the requirements of Section 6 before starting the tests. (See Appendix X1.)

NOTE 19—Ideally, an impact test would be conducted at a constant test velocity. In a pendulum-type test, the velocity decreases as the fracture progresses. For specimens that have an impact energy approaching the capacity of the pendulum there is insufficient energy to complete the break and toss. By avoiding the higher 15 % scale energy readings, the velocity of the pendulum will not be reduced below 1.3 m/s [4.4 ft/s]. On the other hand, the use of too heavy a pendulum would reduce the sensitivity of the reading.

10.3 If the machine is equipped with a mechanical pointer and dial, perform the following operations before testing the specimens:

10.3.1 With the excess energy indicating pointer in its normal starting position but without a specimen in the vise, release the pendulum from its normal starting position and note the position the pointer attains after the swing as one reading of Factor *A*.

10.3.2 Without resetting the pointer, raise the pendulum and release again. The pointer should move up the scale an additional amount. Repeat (10.3.2) until a swing causes no additional movement of the pointer and note the final reading as one reading of Factor *B* (see Note 20).

<sup>6</sup> Supporting data are available from ASTM Headquarters. Request RR: D20-1066.

10.3.3 Repeat the preceding two operations several times and calculate and record the average  $A$  and  $B$  readings.

NOTE 20—Factor  $B$  is an indication of the energy lost by the pendulum to friction in the pendulum bearings and to windage. The difference  $A - B$  is an indication of the energy lost to friction and inertia in the excess energy indicating mechanism. However, the actual corrections will be smaller than these factors, since in an actual test the energy absorbed by the specimen prevents the pendulum from making a full swing. Therefore, the indicated breaking energy of the specimen must be included in the calculation of the machine correction before determining the breaking energy of the specimen (see 10.8). The  $A$  and  $B$  values also provide an indication of the condition of the machine.

10.3.4 If excessive friction is indicated, the machine shall be adjusted before starting a test. If the machine is equipped with a digital energy indicating system, follow the manufacturer's instructions to correct for windage and friction. If excessive friction is indicated, the machine shall be adjusted before starting a test.

10.4 Check the specimens for conformity with the requirements of Sections 7, 8, and 10.1.

10.5 Measure and record the width of each specimen after notching to the nearest 0.025 mm [0.001 in.]. Measure the width in one location adjacent to the notch centered about the anticipated fracture plane.

10.6 Measure and record the depth of material remaining in the specimen under the notch of each specimen to the nearest 0.025 mm [0.001 in.]. The tapered blade will be fitted to the notch. The specimen will be approximately vertical between the anvils. For specimens with a draft angle, position edge of the non-cavity (wider edge) surface centered on the micrometer's flat circular anvil.

10.7 Position the specimen precisely (see 6.7) so that it is rigidly, but not too tightly (see Note 11), clamped in the vise. Pay special attention to ensure that the "impacted end" of the specimen as shown and dimensioned in Fig. 6 is the end projecting above the vise. Release the pendulum and record the excess energy remaining in the pendulum after breaking the specimen, together with a description of the appearance of the broken specimen (see failure categories in 5.8).

10.8 Subtract the windage and friction correction from the indicated breaking energy of the specimen, unless determined automatically by the indicating system (that is, digital display or computer). If a mechanical dial and pointer is employed, use the  $A$  and  $B$  factors and the appropriate tables or the graph described in Annex A1 and Annex A2 to determine the correction. For those digital systems that do not automatically compensate for windage and friction, follow the manufacturer's procedure for performing this correction.

10.8.1 In other words, either manually or automatically, the windage and friction correction value is subtracted from the uncorrected, indicated breaking energy to obtain the new breaking energy. Compare the net value so found with the energy requirement of the hammer specified in 10.2. If a hammer of improper energy was used, discard the result and make additional tests on new specimens with the proper hammer. (See Annex A1 and Annex A2.)

10.9 Divide the net value found in 10.8 by the measured width of the particular specimen to obtain the impact resistance under the notch in J/m [ft·lbf/in.]. If the optional units of  $\text{kJ/m}^2$  [ft·lbf/in.<sup>2</sup>] are used, divide the net value found in 10.8 by the measured width and depth under the notch of the particular specimen to obtain the impact strength. The term, "depth under the notch," is graphically represented by Dimension A in Fig. 6. Consequently, the cross-sectional area (width times depth under the notch) will need to be reported. (See Appendix X4.)

10.10 Calculate the average Izod impact resistance of the group of specimens. However, only values of specimens having the same nominal width and type of break may be averaged. Values obtained from specimens that did not break in the manner specified in 5.8 shall not be included in the average. Also calculate the standard deviation of the group of values.

## 11. Report

11.1 Report the following information:

11.1.1 The test method used (Test Method A, C, D, or E),

11.1.2 Complete identification of the material tested, including type source, manufacturer's code number, and previous history,

11.1.3 A statement of how the specimens were prepared, the testing conditions used, the number of hours the specimens were conditioned after notching, and, for sheet materials, the direction of testing with respect to anisotropy, if any,

11.1.4 The capacity of the pendulum in joules, or foot pound-force, or inch pound-force,

11.1.5 The width and depth under the notch of each specimen tested,

11.1.6 The total number of specimens tested per sample of material,

11.1.7 The type of failure (see 5.8),

11.1.8 The impact resistance must be reported in J/m [ft·lbf/in.]; the optional units of  $\text{kJ/m}^2$  [ft·lbf/in.<sup>2</sup>] may also be required (see 10.9),

11.1.9 The number of those specimens that resulted in failures which conforms to each of the requirement categories in 5.8,

11.1.10 The average impact resistance and standard deviation (in J/m [ft·lbf/in.]) for those specimens in each failure category, except non-break as presented in 5.8. Optional units ( $\text{kJ/m}^2$  [ft·lbf/in.<sup>2</sup>]) may also need to be reported (see Appendix X4), and

11.1.11 The percent of specimens failing in each category suffixed by the corresponding letter code from 5.8.

## TEST METHOD C—CANTILEVER BEAM TEST FOR MATERIALS OF LESS THAN 27 J/m [0.5 ft·lbf/in.]

## 12. Apparatus

12.1 The apparatus shall be the same as specified in Section 6.

### **13. Test Specimens**

13.1 The test specimens shall be the same as specified in Section 7.

### **14. Notching Test Specimens**

14.1 Notching test specimens shall be the same as specified in Section 8.

### **15. Conditioning**

15.1 Specimen conditioning and test environment shall be in accordance with Section 9.

### **16. Procedure**

16.1 The procedure shall be the same as in Section 10 with the addition of a procedure for estimating the energy to toss the broken specimen part.

16.1.1 Make an estimate of the magnitude of the energy to toss each different type of material and each different specimen size (width). This is done by repositioning the free end of the broken specimen on the clamped portion and striking it a second time with the pendulum released in such a way as to impart to the specimen approximately the same velocity it had attained during the test. This is done by releasing the pendulum from a height corresponding to that to which it rose following the breakage of the test specimen. The energy to toss is then considered to be the difference between the reading previously described and the free swing reading obtained from this height. A reproducible method of starting the pendulum from the proper height must be devised.

### **17. Report**

17.1 Report the following information:

17.1.1 Same as 11.1.1,

17.1.2 Same as 11.1.2,

17.1.3 Same as 11.1.3,

17.1.4 Same as 11.1.4,

17.1.5 Same as 11.1.5,

17.1.6 Same as 11.1.6,

17.1.7 The average reversed notch impact resistance, J/m [ft·lbf/in.] (see 5.8 for failure categories),

17.1.8 Same as 11.1.8,

17.1.9 Same as 11.1.9,

17.1.10 Same as 11.1.10, and

17.1.11 Same as 11.1.11.

17.1.12 The estimated toss correction, expressed in terms of joule (J) or foot pound-force (ft·lbf).

17.1.13 The difference between the Izod impact energy and the toss correction energy is the net Izod energy. This value is divided by the specimen width (at the base of notch) to obtain the net Izod impact resistance for the report.

## **TEST METHOD D—NOTCH RADIUS SENSITIVITY TEST**

### **18. Apparatus**

18.1 The apparatus shall be the same as specified in Section 6.

### **19. Test Specimens**

19.1 The test specimens shall be the same as specified in Section 7. All specimens must be of the same nominal width, preferably 6.35-mm [0.25-in.].

### **20. Notching Test Specimens**

20.1 Notching shall be done as specified in Section 8 and Fig. 6, except those ten specimens shall be notched with a radius of 0.25 mm [0.010 in.] and ten specimens with a radius of 1.0 mm [0.040 in.].

### **21. Conditioning**

21.1 Specimen conditioning and test environment shall be in accordance with Section 9.

### **22. Procedure**

22.1 Proceed in accordance with Section 10, testing ten specimens of each notch radius.

22.2 The average impact resistance of each group shall be calculated, except that within each group the type of break must be homogeneously C, H, C and H, or P.

22.3 If the specimens with the 0.25-mm [0.010-in.] radius notch do not break, the test is not applicable.

22.4 If any of ten specimens tested with the 1.0-mm [0.040-in.] radius notch fail as in category NB, non-break, the notch sensitivity procedure cannot be used without obtaining additional data. A new set of specimens should be prepared from the same sample, using a 0.50-mm [0.020-in.] notch radius and the procedure of 22.1 and 22.2 repeated.

### 23. Calculation

23.1 Calculate the slope of the line connecting the values for impact resistance for 0.25 and 1.0-mm notch radii or [0.010 and 0.040-in. notch radii] by the equation presented as follows. (If a 0.500-mm [0.020-in.] notch radius is substituted, adjust the calculation accordingly.)

$$b = (E_2 - E_1)/(R_2 - R_1)$$

where:

- $E_2$  = average impact resistance for the larger notch, J/m of notch,
- $E_1$  = average impact resistance for the smaller notch, J/m of notch,
- $R_2$  = radius of the larger notch, mm, and
- $R_1$  = radius of the smaller notch, mm.

Example:

$$\begin{aligned} E_{1.0} &= 330.95 \text{ J/m}; E_{0.25} = 138.78 \text{ J/m} \\ b &= (330.95 - 138.78 \text{ J/m})/(1.00 - 0.25 \text{ mm}) \\ b &= 192.17 \text{ J/m } 0.75 \text{ mm} \\ &= 256.23 \text{ J/m} \\ &\text{of notch per mm of radius} \end{aligned}$$

### 24. Report

24.1 Report the following information:

- 24.1.1 Same as 11.1.1,
- 24.1.2 Same as 11.1.2,
- 24.1.3 Same as 11.1.3,
- 24.1.4 Same as 11.1.4,
- 24.1.5 Same as 11.1.5,
- 24.1.6 Same as 11.1.6,
- 24.1.7 The average reversed notch impact resistance, in J/m [ft·lbf/in.] (see 5.8 for failure categories),
- 24.1.8 Same as 11.1.8,
- 24.1.9 Same as 11.1.9,
- 24.1.10 Same as 11.1.10, and
- 24.1.11 Same as 11.1.11.
- 24.1.12 Report the average value of  $b$  with its units, and the average Izod impact resistance for a 0.25-mm [0.010-in.] notch.

## TEST METHOD E—CANTILEVER BEAM REVERSED NOTCH TEST

### 25. Apparatus

25.1 The apparatus shall be the same as specified in Section 6.

### 26. Test Specimens

26.1 The test specimen shall be the same as specified in Section 7.

### 27. Notching Test Specimens

27.1 Notch the test specimens in accordance with Section 8.

### 28. Conditioning

28.1 Specimen conditioning and test environment shall be in accordance with Section 9.

### 29. Procedure

29.1 Proceed in accordance with Section 10, except clamp the specimen so that the striker impacts it on the face opposite the notch, hence subjecting the notch to compressive rather than tensile stresses during impact (see Fig. 2 and Note 21, Note 22, and Note 23).

NOTE 21—The reversed notch test employs a standard 0.25-mm [0.010-in.] notch specimen to provide an indication of unnotched impact resistance. Use of the reversed notch test obviates the need for machining unnotched specimens to the required  $10.2 \pm 0.05$ -mm [ $0.400 \pm 0.002$ -in.] depth before testing and provides the same convenience of specimen mounting as the standard notch tests (Test Methods A and C).

NOTE 22—Results obtained by the reversed notch test may not always agree with those obtained on unnotched bars that have been machined to the 10.2-mm [0.400-in.] depth requirement. For some materials, the effects arising from the difference in the clamped masses of the two specimen types during test, and those attributable to a possible difference in toss energies ascribed to the broken ends of the respective specimens, may contribute significantly to a disparity in test results.

NOTE 23—Where materials are suspected of anisotropy, due to molding or other fabricating influences, notch reversed notch specimens on the face opposite to that used for the standard Izod test; that is, present the same face to the impact blow.

### 30. Report

30.1 Report the following information:

- 30.1.1 Same as 11.1.1,
- 30.1.2 Same as 11.1.2,
- 30.1.3 Same as 11.1.3,
- 30.1.4 Same as 11.1.4,
- 30.1.5 Same as 11.1.5,
- 30.1.6 Same as 11.1.6,
- 30.1.7 The average reversed notch impact resistance, J/m [ft·lbf/in.] (see 5.8 for failure categories),
- 30.1.8 Same as 11.1.8,
- 30.1.9 Same as 11.1.9,
- 30.1.10 Same as 11.1.10, and
- 30.1.11 Same as 11.1.11.

### 31. Precision and Bias

31.1 Table 1 and Table 2 are based on a round robin<sup>7</sup> in accordance with Practice E 691. For each material, all the test bars were prepared at one source, except for notching. Each participating laboratory notched the bars that they tested. Table 1 and Table 2 are presented on the basis of a test result being the average for five specimens. In the round robin each laboratory tested, on average, nine specimens of each material.

31.2 Table 3 is based on a round robin<sup>5</sup> involving five materials tested by seven laboratories. For each material, all the samples were prepared at one source, and the individual specimens were all notched at the same laboratory. Table 3 is presented on the basis of a test result being the average for five specimens. In the round robin, each laboratory tested ten specimens of each material.

31.3 *Concept of  $I_r$  and  $I_R$* —**Warning**—The following explanations of  $I_r$  and  $I_R$  (see 31.3-31.3.3) are only intended to present a meaningful way of considering the precision of this test method. The data in Tables 1-3 should not be rigorously applied to acceptance or rejection of material, as those data are specific to the round robin and may not be representative of other lots, conditions, materials, or laboratories. Users of this test method should apply the principles outlined in Practice E 691 to generate data specific to their laboratory and materials, or between specific laboratories. The principles of 31.3-31.3.3 would then be valid for such data.

If  $S_r$  and  $S_R$  have been calculated from a large enough body of data, and for test results that were averages from testing five specimens.

31.3.1 *Repeatability,  $I_r$  (Comparing Two Test Results for the Same Material, Obtained by the Same Operator Using the Same Equipment on the Same Day)*—The two test results should be judged not equivalent if they differ by more than the  $I_r$  value for that material.

31.3.2 *Reproducibility,  $I_R$  (Comparing Two Test Results for the Same Material, Obtained by Different Operators Using Different Equipment on Different Days)*—The two test results should be judged not equivalent if they differ by more than the  $I_R$  value for that material.

31.3.3 Any judgment in accordance with 31.3.1 and 31.3.2 would have an approximate 95 % (0.95) probability of being correct.

31.4 *Bias*—There is no recognized standards by which to estimate bias of these test methods.

<sup>7</sup> Supporting data are available from ASTM Headquarters. Request RR: D20-1034.

**TABLE 1 Precision Data, Test Method A—Reversed Notch Izod**

NOTE 1—Values in ft·lbf/in. of width [J/m of width].

NOTE 2—See Footnote 10.

Material	Average	$S_r^A$	$S_R^B$	$I_r^C$	$I_R^D$	Number of Laboratories
Phenolic	0.57 [30.4]	0.024 [1.3]	0.076 [4.1]	0.06 [3.2]	0.21 [11.2]	19
Acetal	1.45 [77.4]	0.075 [4.0]	0.604 [32.3]	0.21 [11.2]	1.70 [90.8]	9
Reinforced nylon	1.98 [105.7]	0.083 [4.4]	0.245 [13.1]	0.23 [12.3]	0.69 [36.8]	15
Polypropylene	2.66 [142.0]	0.154 [8.2]	0.573 [30.6]	0.43 [23.0]	1.62 [86.5]	24
ABS	10.80 [576.7]	0.136 [7.3]	0.585 [31.2]	0.38 [20.3]	1.65 [88.1]	25
Polycarbonate	16.40 [875.8]	0.295 [15.8]	1.056 [56.4]	0.83 [44.3]	2.98 [159.1]	25

<sup>A</sup>  $S_r$  = within-laboratory standard deviation of the average.

<sup>B</sup>  $S_R$  = between-laboratories standard deviation of the average.

<sup>C</sup>  $I_r$  = 2.83  $S_r$ .

<sup>D</sup>  $I_R$  = 2.83  $S_R$ .

**TABLE 2 Precision Data, Test Method C—Reversed Notch Izod**

NOTE 1—Values in ft·lbf/in. of width [J/m of width].  
NOTE 2—See Footnote 10.

Material	Average	$S_r^A$	$S_R^B$	$I_r^C$	$I_R^D$	Number of Laboratories
Phenolic	0.45 [24.0]	0.038 [2.0]	0.129 [6.9]	0.10 [5.3]	0.36 [19.2]	15

<sup>A</sup>  $S_r$  = within-laboratory standard deviation of the average.  
<sup>B</sup>  $S_R$  = between-laboratories standard deviation of the average.  
<sup>C</sup>  $I_r = 2.83 S_r$ .  
<sup>D</sup>  $I_R = 2.83 S_R$ .

**TABLE 3 Precision Data, Test Method E—Reversed Notch Izod**

NOTE 1—Values in ft·lbf/in. of width [J/m of width].  
NOTE 2—See Footnote 8.

Material	Average	$S_r^A$	$S_R^B$	$I_r^C$	$I_R^D$
Acrylic sheet, unmodified	3.02 [161.3]	0.243 [13.0]	0.525 [28.0]	0.68 [36.3]	0.71 [37.9]
Premix molding compounds laminate acrylic, injection molded	6.11 [326.3]	0.767 [41.0]	0.786 [42.0]	2.17 [115.9]	2.22 [118.5]
compound (SMC) laminate	10.33 [551.6]	0.878 [46.9]	1.276 [68.1]	2.49 [133.0]	3.61 [192.8]
Preformed mat laminate	11.00 [587.4]	0.719 [38.4]	0.785 [41.9]	2.03 [108.4]	2.22 [118.5]
Preformed mat laminate	19.43 [1037.6]	0.960 [51.3]	1.618 [86.4]	2.72 [145.2]	4.58 [244.6]

<sup>A</sup>  $S_r$  = within-laboratory standard deviation of the average.  
<sup>B</sup>  $S_R$  = between-laboratories standard deviation of the average.  
<sup>C</sup>  $I_r = 2.83 S_r$ .  
<sup>D</sup>  $I_R = 2.83 S_R$ .

NOTE 24—Numerous changes have occurred since the collection of the original round-robin data in 1973.<sup>7</sup> Consequently, a new task group has been formed to evaluate a precision and bias statement for the latest revision of these test methods.

### 32. Keywords

32.1 impact resistance; Izod impact; notch sensitivity; notched specimen; reverse notch impact

## ANNEXES

### (Mandatory Information)

#### A1. INSTRUCTIONS FOR THE CONSTRUCTION OF A WINDAGE AND FRICTION CORRECTION CHART

A1.1 The construction and use of the chart herein described is based upon the assumption that the friction and windage losses are proportional to the angle through which these loss torques are applied to the pendulum. Fig. A1.1 shows the assumed energy loss versus the angle of the pendulum position during the pendulum swing. The correction chart to be described is principally the left half of Fig. A1.1. The windage and friction correction charts should be available from commercial testing machine manufacturers. The energy losses designated as *A* and *B* are described in 10.3.

A1.2 Start the construction of the correction chart (see Fig. A1.2) by laying off to some convenient linear scale on the abscissa of a graph the angle of pendulum position for the portion of the swing beyond the free hanging position. For convenience, place the free hanging reference point on the right end of the abscissa with the angular displacement increasing linearly to the left. The

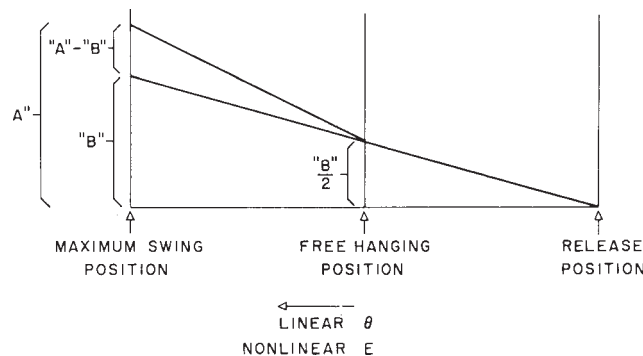

**FIG. A1.1 Method of Construction of a Windage and Friction Correction Chart**

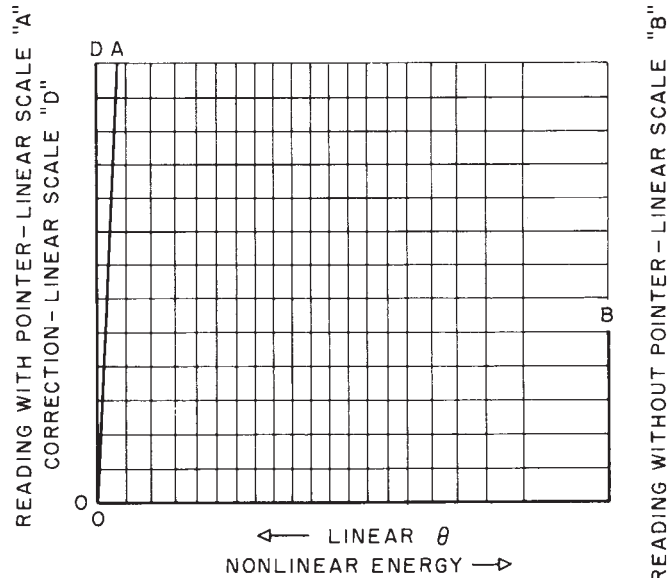

FIG. A1.2 Sample Windage and Friction Correction Chart

abscissa is referred to as Scale C. Although angular displacement is the quantity to be represented linearly on the abscissa, this displacement is more conveniently expressed in terms of indicated energy read from the machine dial. This yields a nonlinear Scale C with indicated pendulum energy increasing to the right.

A1.3 On the right-hand ordinate lay off a linear Scale B starting with zero at the bottom and stopping at the maximum expected pendulum friction and windage value at the top.

A1.4 On the left ordinate construct a linear Scale D ranging from zero at the bottom to 1.2 times the maximum ordinate value appearing on Scale B, but make the scale twice the scale used in the construction of Scale B.

A1.5 Adjoining Scale D draw a curve OA that is the focus of points whose coordinates have equal values of energy correction on Scale D and indicated energy on Scale C. This curve is referred to as Scale A and utilizes the same divisions and numbering system as the adjoining Scale D.

*A1.6 Instructions for Using Chart:*

A1.6.1 Locate and mark on Scale A the reading A obtained from the free swing of the pendulum with the pointer prepositioned in the free hanging or maximum indicated energy position on the dial.

A1.6.2 Locate and mark on Scale B the reading B obtained after several free swings with the pointer pushed up close to the zero indicated energy position of the dial by the pendulum in accordance with instructions in 10.3.

A1.6.3 Connect the two points thus obtained by a straight line.

A1.6.4 From the indicated impact energy on Scale C project up to the constructed line and across to the left to obtain the correction for windage and friction from Scale D.

A1.6.5 Subtract this correction from the indicated impact reading to obtain the energy delivered to the specimen.

**A2. PROCEDURE FOR THE CALCULATION OF WINDAGE AND FRICTION CORRECTION**

A2.1 The procedure for the calculation of the windage and friction correction in this annex is based on the equations developed by derivation in Appendix X3. This procedure can be used as a substitute for the graphical procedure described in Annex A1 and is applicable to small electronic calculator and computer analysis.

A2.2 Calculate  $L$ , the distance from the axis of support to the center of percussion as indicated in 6.3. (It is assumed here that the center of percussion is approximately the same as the center of gravity.)

A2.3 Measure the maximum height,  $h_M$ , of the center of percussion (center of gravity) of the pendulum at the start of the test as indicated in X2.16.

A2.4 Measure and record the energy correction,  $E_A$ , for windage of the pendulum plus friction in the dial, as determined with the first swing of the pendulum with no specimen in the testing device. This correction must be read on the energy scale,  $E_M$ , appropriate for the pendulum used.

A2.5 Without resetting the position of the indicator obtained in A2.4, measure the energy correction,  $E_B$ , for pendulum windage after two additional releases of the pendulum with no specimen in the testing device.

A2.6 Calculate  $\beta_{\max}$  as follows:

$$\beta_{\max} = \cos^{-1} \{1 - [(h_M/L)(1 - E_A/E_M)]\}$$

where:

- $E_A$  = energy correction for windage of pendulum plus friction in dial, J [ft·lbf],
- $E_M$  = full-scale reading for pendulum used, J [ft·lbf],
- $L$  = distance from fulcrum to center of gravity of pendulum, m [ft],
- $h_M$  = maximum height of center of gravity of pendulum at start of test, m [ft], and
- $\beta_{\max}$  = maximum angle pendulum will travel with one swing of the pendulum.

A2.7 Measure specimen breaking energy,  $E_s$ , J [ft·lbf].

A2.8 Calculate  $\beta$  for specimen measurement  $E_s$  as:

$$\beta = \cos^{-1} \{1 - [(h_M/L)(1 - E_s/E_M)]\}$$

where:

- $\beta$  = angle pendulum travels for a given specimen, and
- $E_s$  = dial reading breaking energy for a specimen, J [ft·lbf].

A2.9 Calculate total correction energy,  $E_{TC}$ , as:

$$E_{TC} = (E_A - (E_B^2/2))(\beta/\beta_{\max}) + (E_B/2)$$

where:

- $E_{TC}$  = total correction energy for the breaking energy,  $E_s$ , of a specimen, J [ft·lbf], and
- $E_B$  = energy correction for windage of the pendulum, J [ft·lbf].

A2.10 Calculate the impact resistance using the following formula:

$$I_s = (E_s - E_{TC})/t$$

where:

- $I_s$  = impact resistance of specimen, J/m [ft·lbf/in.] of width, and
- $t$  = width of specimen or width of notch, m [in.].

## APPENDIXES

### (Nonmandatory Information)

#### X1. PROCEDURE FOR THE INSPECTION AND VERIFICATION OF NOTCH

X1.1 The purpose of this procedure is to describe the microscopic method to be used for determining the radius and angle of the notch. These measurements could also be made using a comparator if available.

NOTE X1.1—The notch shall have a radius of  $0.25 \pm 0.05$  mm [ $0.010 \pm 0.002$  in.] and an angle of  $45 \pm 1^\circ$ .

X1.2 *Apparatus:*

X1.2.1 *Optical Device* with minimum magnification of 60×, Filar glass scale and camera attachment.

X1.2.2 *Transparent Template*, (will be developed in this procedure).

X1.2.3 *Ruler*.

X1.2.4 *Compass*.

X1.2.5 *Plastic 45°–45°–90° Drafting Set Squares (Triangles)*.

X1.3 A transparent template must be developed for each magnification and for each microscope used. It is preferable that each laboratory standardize on one microscope and one magnification. It is not necessary for each laboratory to use the same magnification because each microscope and camera combination has somewhat different blowup ratios.

X1.3.1 Set the magnification of the optical device at a suitable magnification with a minimum magnification of 60×.

X1.3.2 Place the Filar glass slide on the microscope platform. Focus the microscope so the most distinct image of the Filar scale is visible.

X1.3.3 Take a photograph of the Filar scale (see Fig. X1.1).

X1.3.4 Create a template similar to that shown in Fig. X1.2.

X1.3.4.1 Find the approximate center of the piece of paper.

X1.3.4.2 Draw a set of perpendicular coordinates through the center point.

X1.3.4.3 Draw a family of concentric circles that are spaced according to the dimensions of the Filar scale.

X1.3.4.4 This is accomplished by first setting a mechanical compass at a distance of 0.1 mm [0.004 in.] as referenced by the magnified photograph of the Filar eyepiece. Subsequent circles shall be spaced 0.02 mm apart [0.001 in.], as rings with the outer ring being 0.4 mm [0.016 in.] from the center.

X1.3.5 Photocopy the paper with the concentric circles to make a transparent template of the concentric circles.

X1.3.6 Construct Fig. X1.3 by taking a second piece of paper and find its approximate center and mark this point. Draw one line through this center point. Label this line zero degree (0°). Draw a second line perpendicular to the first line through this center point. Label this line "90°." From the center draw a line that is 44 degrees relative to the "0°." Label the line "44°." Draw another line at 46°. Label the line "46°."

X1.4 Place a microscope glass slide on the microscope platform. Place the notched specimen on top of the slide. Focus the microscope. Move the specimen around using the platform adjusting knobs until the specimen's notch is centered and near the bottom of the viewing area. Take a picture of the notch.

X1.4.1 *Determination of Notching Radius* (see Fig. X1.4):

X1.4.1.1 Place the picture on a sheet of paper. Position the picture so that bottom of the notch in the picture faces downwards and is about 64 mm [2.5 in.] from the bottom of the paper. Tape the picture down to the paper.

X1.4.1.2 Draw two lines along the sides of the notch projecting down to a point where they intersect below Notch Point I (see Fig. X1.4).

X1.4.1.3 Open the compass to about 51 mm [2 in.]. Using Point I as a reference, draw two arcs intersecting both sides of the

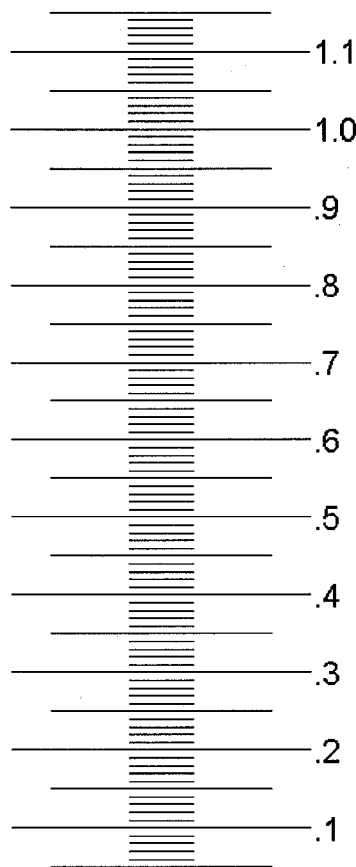

NOTE 1—100X reference.

NOTE 2—0.1 mm major scale; 0.01 mm minor scale.

FIG. X1.1 Filar Scale

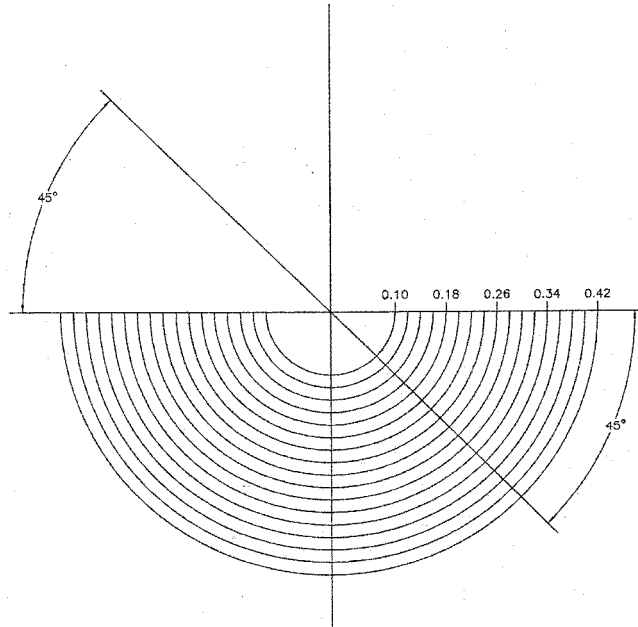

NOTE 1—Magnification = 100X.

**FIG. X1.2 Example of Transparent Template for Determining Radius of Notch**

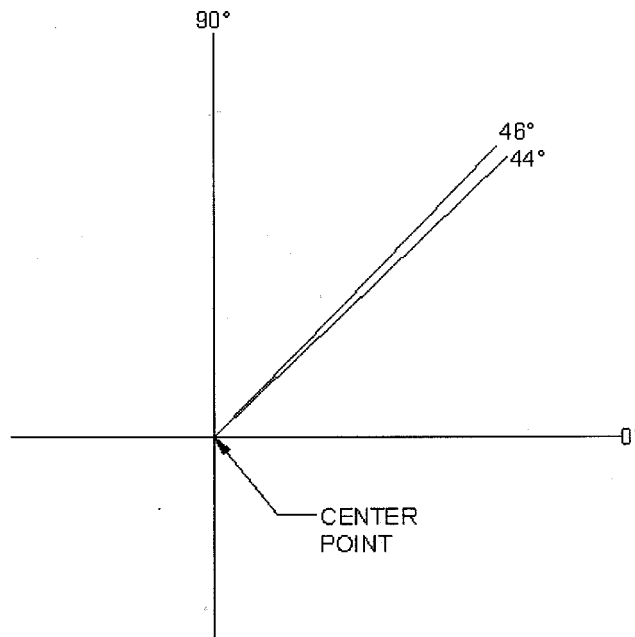

**FIG. X1.3 Example of Transparent Template for Determining Angle of Notch**

notch (see Fig. X1.4). These intersections are called 1a and 1b.

X1.4.1.4 Close the compass to about 38 mm [1.5 in.]. Using Point 1a as the reference point draw an arc (2a) above the notch, draw a second arc (2b) that intersects with arc 2a at Point J. Draw a line between I and J. This establishes the centerline of the notch (see Fig. X1.4).

X1.4.1.5 Place the transparent template on top of the picture and align the center of the concentric circles with the drawn centerline of the notch (see Fig. X1.4).

X1.4.1.6 Slide the template down the centerline of the notch until one concentric circle touches both sides of the notch. Record

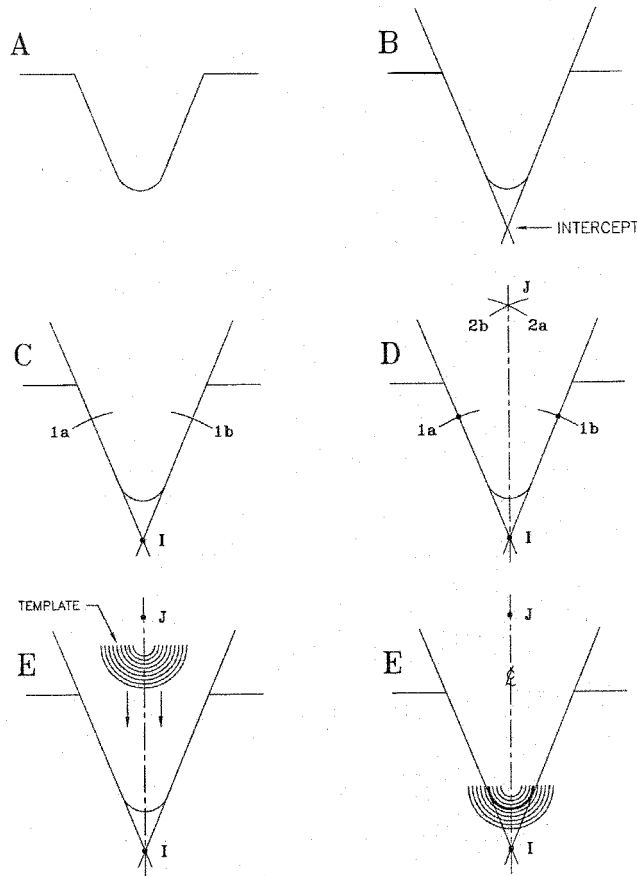

FIG. X1.4 Determination of Notching Radius

the radius of the notch and compare it against the ASTM limits of 0.2 to 0.3 mm [0.008 to 0.012 in.].

X1.4.1.7 Examine the notch to ensure that there are no flat spots along the measured radius.

X1.4.2 *Determination of Notch Angle :*

X1.4.2.1 Place transparent template for determining notch angle (see Fig. X1.3) on top of the photograph attached to the sheet of paper. Rotate the picture so that the notch tip is pointed towards you. Position the center point of the template on top of Point I established in 0° axis of the template with the right side straight portion of the notch. Check the left side straight portion of the notch to ensure that this portion falls between the 44 and 46° degree lines. If not, replace the blade.

X1.5 A picture of a notch shall be taken at least every 500 notches or if a control sample gives a value outside its three-sigma limits for that test.

X1.6 If the notch in the control specimen is not within the requirements, a picture of the notching blade should be taken and analyzed by the same procedure used for the specimen notch. If the notching blade does not meet ASTM requirements or shows damage, it should be replaced with a new blade which has been checked for proper dimensions.

X1.7 It is possible that the notching cutter may have the correct dimensions but does not cut the correct notch in the specimen. If that occurs it will be necessary to evaluate other conditions (cutter and feed speeds) to obtain the correct notch dimension for that material.

## X2. CALIBRATION OF PENDULUM-TYPE HAMMER IMPACT MACHINES FOR USE WITH PLASTIC SPECIMENS

X2.1 This calibration procedure applies specifically to the Izod impact machine. However, much of this procedure can be applied to the Charpy impact machine as well.

X2.2 Locate the impact machine on a sturdy base. It shall not “walk” on the base and the base shall not vibrate appreciably. Loss of energy from vibrations will give high readings. It is recommended that the impact tester be bolted to a base having a mass of at least 23 kg if it is used at capacities higher than 2.7 J [2 ft·lbf].

X2.3 Check the level of the machine in both directions in the plane of the base with spirit levels mounted in the base, by a machinist's level if a satisfactory reference surface is available, or with a plumb bob. The machine should be made level to within  $\tan^{-1} 0.001$  in the plane of swing and to within  $\tan^{-1} 0.002$  in the plane perpendicular to the swing.

X2.4 With a straightedge and a feeler gage or a depth gage, check the height of the movable vise jaw relative to the fixed vise jaw. It must match the height of the fixed vise jaw within 0.08 mm [0.003 in.].

X2.5 Contact the machine manufacturer for a procedure to ensure the striker radius is in tolerance ( $0.80 \pm 0.20$  mm) (see 6.3).

X2.6 Check the transverse location of the center of the pendulum striking edge that shall be within 0.40 mm [0.016 in.] of the center of the vise. Readjust the shaft bearings or relocate the vise, or straighten the pendulum shaft as necessary to attain the proper relationship between the two centers.

X2.7 Check the pendulum arm for straightness within 1.2 mm [0.05 in.] with a straightedge or by sighting down the shaft. Allowing the pendulum to slam against the catch sometimes bends the arm especially when high-capacity weights are on the pendulum.

X2.8 Insert vertically and center with a locating jig and clamp in the vise a notched machined metal bar 12.7-mm [0.500-in.] square, having opposite sides parallel within 0.025 mm [0.001 in.] and a length of 60 mm [2.4 in.]. Check the bar for vertical alignment within  $\tan^{-1} 0.005$  in both directions with a small machinist's level. Shim up the vise, if necessary, to correct for errors in the plane of pendulum swing, using care to preserve solid support for the vise. For errors in the plane perpendicular to the plane of pendulum swing, machine the inside face of the clamp-type locating jig for correct alignment if this type of jig is used. If a blade-type jig is used, use shims or grind the base of the vise to bring the top surface level.

X2.9 Insert and clamp the bar described in X2.8 in a vertical position in the center of the vise so that the notch in the bar is slightly below the top edge of the vise. Place a thin film of oil on the striking edge of the pendulum with an oiled tissue and let the striking edge rest gently against the bar. The striking edge should make contact across the entire width of the bar. If only partial contact is made, examine the vise and pendulum for the cause. If the cause is apparent, make the appropriate correction. If no cause is apparent, remove the striker and shim up or grind its back face to realign the striking edge with the surface of the bar.

X2.10 Check the oil line on the face of the bar for horizontal setting of striking edge within  $\tan^{-1} 0.002$  with a machinist's square.

X2.11 Without taking the bar of X2.8 from the vise of the machine, scratch a thin line at the top edge of the vise on the face opposite the striking face of the bar. Remove the bar from the vise and transfer this line to the striking face, using a machinist's square. The distance from the striking oil line to the top edge of the vise should be  $22 \pm 0.05$  mm [ $0.87 \pm 0.002$  in.]. Correct with shims or grinding, as necessary, at the bottom of the vise.

X2.12 When the pendulum is hanging free in its lowest position, the energy reading must be within 0.2 % of full scale.

X2.13 Insert the bar of X2.8 into the vise and clamp it tightly in a vertical position. When the striking edge is held in contact with the bar, the energy reading must be within 0.2 % of full scale.

X2.14 Swing the pendulum to a horizontal position and support it by the striking edge in this position with a vertical bar. Allow the other end of this bar to rest at the center of a load pan on a balanced scale. Subtract the weight of the bar from the total weight to find the effective weight of the pendulum. The effective pendulum weight should be within 0.4 % of the required weight for that pendulum capacity. If weight must be added or removed, take care to balance the added or removed weight without affecting the center of percussion relative to the striking edge. It is not advisable to add weight to the opposite side of the bearing axis from the striking edge to decrease the effective weight of the pendulum since the distributed mass can lead to large energy losses from vibration of the pendulum.

X2.15 Calculate the effective length of the pendulum arm, or the distance to the center of percussion from the axis of rotation, by the procedure in Note 9. The effective length must be within the tolerance stated in 6.3.

X2.16 Measure the vertical distance of fall of the pendulum striking edge from its latched height to its lowest point. This distance should be  $610 \pm 2.0$  mm [ $24 \pm 0.1$  in.]. This measurement may be made by blocking up a level on the top of the vise and measuring the vertical distance from the striking edge to the bottom of the level (top of vise) and subtracting 22.0 mm [0.9 in.]. The vertical falling distance may be adjusted by varying the position of the pendulum latch.

X2.17 Notch a standard specimen on one side, parallel to the molding pressure, at 32 mm [1.25 in.] from one end. The depth of the plastic material remaining in the specimen under the notch shall be  $10.16 \pm 0.05$  mm [ $0.400 \pm 0.002$  in.]. Use a jig to position the specimen correctly in the vise. When the specimen is clamped in place, the center of the notch should be within 0.12 mm [0.005 in.] of being in line with the top of the fixed surface of the vise and the specimen should be centered midway within

0.40 mm [0.016 in.] between the sides of the clamping faces. The notched face should be the striking face of the specimen for the Izod test. Under no circumstances during the breaking of the specimen should the top of the specimen touch the pendulum except at the striking edge.

X2.18 If a clamping-type locating jig is used, examine the clamping screw in the locating jig. If the thread has a loose fit the specimen may not be correctly positioned and may tend to creep as the screw is tightened. A burred or bent point on the screw may also have the same effect.

X2.19 If a pointer and dial mechanism is used to indicate the energy, the pointer friction should be adjusted so that the pointer will just maintain its position anywhere on the scale. The striking pin of the pointer should be securely fastened to the pointer. Friction washers with glazed surfaces should be replaced with new washers. Friction washers should be on either side of the pointer collar. A heavy metal washer should back the last friction washer installed. Pressure on this metal washer is produced by a thin-bent, spring washer and locknuts. If the spring washer is placed next to the fiber friction washer the pointer will tend to vibrate during impact.

X2.20 The free-swing reading of the pendulum (without specimen) from the latched height should be less than 2.5 % of pendulum capacity on the first swing. If the reading is higher than this, then the friction in the indicating mechanism is excessive or the bearings are dirty. To clean the bearings, dip them in grease solvent and spin-dry in an air jet. Clean the bearings until they spin freely, or replace them. Oil very lightly with instrument oil before replacing. A reproducible method of starting the pendulum from the proper height must be devised.

X2.21 The shaft about which the pendulum rotates shall have no detectable radial play (less than 0.05 mm [0.002 in.]). An endplay of 0.25 mm [0.010 in.] is permissible when a 9.8-N [2.2-lbf] axial force is applied in alternate directions.

X2.22 The clamping faces of the vise should be parallel in the horizontal and vertical directions within 0.025 mm [0.001 in.]. Inserting the machined square metal bar of X2.7 into the vise in a vertical position and clamping until the jaws begin to bind may check parallelism. Any freedom between the metal bar and the clamping surfaces of the jaws of the vise must not exceed the specified tolerance.

X2.23 The top edges of the fixed and moveable jaws of the vise shall have a radius of  $0.25 \pm 0.12$  mm [ $0.010 \pm 0.005$  in.]. Depending upon whether Test Method A, C, D, or E is used, a stress concentration may be produced as the specimen breaks. Consequently, the top edge of the fixed and moveable jaw needs to be carefully examined.

X2.24 If a brittle unfilled or granular-filled plastic bar such as a general-purpose wood-flour-filled phenolic material is available, notch and break a set of bars in accordance with these test methods. Examine the surface of the break of each bar in the vise. If the break is flat and smooth across the top surface of the vise, the condition of the machine is excellent. Considerable information regarding the condition of an impact machine can be obtained by examining the broken sections of specimens. No weights should be added to the pendulum for the preceding tests.

X2.25 The machine should not be used to indicate more than 85 % of the energy capacity of the pendulum. Extra weight added to the pendulum will increase available energy of the machine. This weight must be added so as to maintain the center of percussion within the tolerance stated in 6.3. Correct effective weight for any range can be calculated as follows:

$$W = E_p/h$$

where:

$W$  = effective pendulum weight, N [lbf] (see X2.13),

$E_p$  = potential or available energy of the machine, J [ft·lbf], and

$h$  = vertical distance of fall of the pendulum striking edge, m [ft] (see X2.16).

Each 4.5 N [1 lbf] of added effective weight increases the capacity of the machine by 2.7 J [2 ft·lbf].

NOTE X2.1—If the pendulum is designed for use with add-on weight, it is recommended that it be obtained through the equipment manufacturer.

### X3. DERIVATION OF PENDULUM IMPACT CORRECTION EQUATIONS

X3.1 From right triangle distances in Fig. X3.1:

$$L - h = L \cos \beta \tag{X3.1}$$

X3.2 But the potential energy gain of pendulum  $E_p$  is:

$$E_p = hW_p g \tag{X3.2}$$

X3.3 Combining Eq X3.1 and Eq X3.2 gives the following:

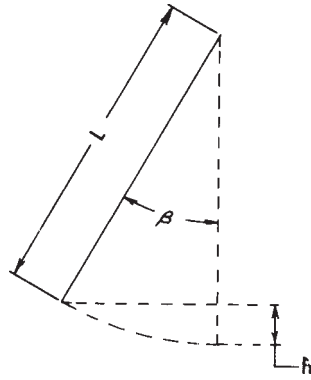

FIG. X3.1 Swing of Pendulum from Its Rest Position

$$L - E_p/W_p g = L \cos \beta \tag{X3.3}$$

X3.4 The maximum energy of the pendulum is the potential energy at the start of the test,  $E_M$ , or

$$E_M = h_M W_p g \tag{X3.4}$$

X3.5 The potential energy gained by the pendulum,  $E_p$ , is related to the absorption of energy of a specimen,  $E_s$ , by the following equation:

$$E_M - E_s = E_p \tag{X3.5}$$

X3.6 Combining Eq X3.3-X3.5 gives the following:

$$(E_M - E_s)/E_M = L/h_M (1 - \cos \beta) \tag{X3.6}$$

X3.7 Solving Eq X3.6 for  $\beta$  gives the following:

$$\beta = \cos^{-1}\{1 - [(h_M/L)(1 - E_s/E_M)]\} \tag{X3.7}$$

X3.8 From Fig. X3.2, the total energy correction  $E_{TC}$  is given as:

$$E_{TC} = m\beta + b \tag{X3.8}$$

X3.9 But at the zero point of the pendulum potential energy:

$$E_B/2 = m(0) + b \tag{X3.9}$$

or:

$$b = E_B/2 \tag{X3.10}$$

X3.10 The energy correction,  $E_A$ , on the first swing of the pendulum occurs at the maximum pendulum angle,  $\beta_{max}$ . Substituting in Eq X3.8 gives the following:

$$E_A = m\beta_{max} + (E_B/2) \tag{X3.11}$$

X3.11 Combining Eq X3.8 and Eq X3.11 gives the following:

$$E_{TC} = (E_A - (E_B/2))(\beta/\beta_{max}) + (E_B/2) \tag{X3.12}$$

X3.12 *Nomenclature:*

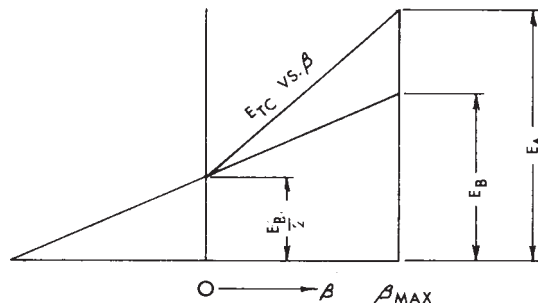

FIG. X3.2 Total Energy Correction for Pendulum Windage and Dial Friction as a Function of Pendulum Position

$b$	= intercept of total correction energy straight line,
$E_A$	= energy correction, including both pendulum windage plus dial friction, J,
$E_B$	= energy correction for pendulum windage only, J,
$E_M$	= maximum energy of the pendulum (at the start of test), J,
$E_p$	= potential energy gain of pendulum from the pendulum rest position, J,
$E_s$	= uncorrected breaking energy of specimen, J,
$E_{TC}$	= total energy correction for a given breaking energy, $E_s$ , J,
$g$	= acceleration of gravity, $m/s^2$ ,
$h$	= distance center of gravity of pendulum rises vertically from the rest position of the pendulum, m,
$h_M$	= maximum height of the center of gravity of the pendulum, m,
$m$	= slope of total correction energy straight line,
$L$	= distance from fulcrum to center of gravity of pendulum, m,
$W_p$	= weight of pendulum, as determined in X2.13, kg, and
$\beta$	= angle of pendulum position from the pendulum rest position.

#### X4. UNIT CONVERSIONS

X4.1 Joules per metre (J/m) cannot be converted directly into  $kJ/m^2$ . Note that the optional units of  $kJ/m^2$  [ft·lbf/in.<sup>2</sup>] may also be required; therefore, the cross-sectional area under the notch must be reported.

X4.2 The following examples are approximations:

X4.2.1 *Example 1:*

1 ft·lbf/39.37 in.	= 1.356 J/m
1 ft·lbf/in.	= (39.37)(1.356) J/m
1 ft·lbf/in.	= 53.4 J/m
1 ft·lbf/in.	= 0.0534 kJ/m

X4.2.2 *Example 2:*

1 ft·lbf/1550 in. <sup>2</sup>	= 1.356 J/m <sup>2</sup>
1 ft·lbf/in. <sup>2</sup>	= (1550)(1.356) J/m <sup>2</sup>
1 ft·lbf/in. <sup>2</sup>	= 2101 J/m <sup>2</sup>
1 ft·lbf/in. <sup>2</sup>	= 2.1 kJ/m <sup>2</sup>

#### SUMMARY OF CHANGES

This section identifies the location of selected changes to these test methods. For the convenience of the user, Committee D20 has highlighted those changes that may impact the use of this test method. This section may also include descriptions of the changes or reasons for the changes, or both.

**D 256 – 04:**

(1) Replaced Figs. X1.1-X1.4 with clearer versions.

**D 256 – 03:**

(1) Added reference to Test Methods D 5947.

(2) Added paragraphs 6.13 and 10.6.

(3) Revised paragraphs 8.4 and 10.5.

**D 256 – 02:**

(1) Value conversions corrected in 7.2.1, 7.2.2., and 7.4.1.

(2) Added new paragraph 7.1.1. Renumbered subsequent paragraphs.

(3) Fixed Fig. 5 to reflect paragraph location for width measurement.

**D 256 – 00:**

(1) Notch depth dimensions in 8.4, Fig. 6, and X2.17 changed to  $10.16 \pm 0.05$  mm.

(2) Note 8 added.

(3) Deleted former Appendix X4 on Determination of Clamping Load on Izod Specimens.

**D 256 – 97:**

(1) Test Method B (Charpy) has been removed from these test methods. This test method is being developed as a separate standard. Research Report D20-1034 will be moved to the new charpy standard.

(2) The designations for Test Methods A, C, D, or E remain unchanged due to potential problems with historical data.

(3) These test methods have been extensively revised, editorially and technically, with major emphasis on tolerances and units.

*ASTM International takes no position respecting the validity of any patent rights asserted in connection with any item mentioned in this standard. Users of this standard are expressly advised that determination of the validity of any such patent rights, and the risk of infringement of such rights, are entirely their own responsibility.*

*This standard is subject to revision at any time by the responsible technical committee and must be reviewed every five years and if not revised, either reapproved or withdrawn. Your comments are invited either for revision of this standard or for additional standards and should be addressed to ASTM International Headquarters. Your comments will receive careful consideration at a meeting of the responsible technical committee, which you may attend. If you feel that your comments have not received a fair hearing you should make your views known to the ASTM Committee on Standards, at the address shown below.*

*This standard is copyrighted by ASTM International, 100 Barr Harbor Drive, PO Box C700, West Conshohocken, PA 19428-2959, United States. Individual reprints (single or multiple copies) of this standard may be obtained by contacting ASTM at the above address or at 610-832-9585 (phone), 610-832-9555 (fax), or [service@astm.org](mailto:service@astm.org) (e-mail); or through the ASTM website ([www.astm.org](http://www.astm.org)).*