



Standard Test Method for Density of Smoke from the Burning or Decomposition of Plastics¹

This standard is issued under the fixed designation D 2843; the number immediately following the designation indicates the year of original adoption or, in the case of revision, the year of last revision. A number in parentheses indicates the year of last reapproval. A superscript epsilon (ϵ) indicates an editorial change since the last revision or reapproval.

This standard has been approved for use by agencies of the Department of Defense.

1. Scope

1.1 This fire-test-response test method covers a laboratory procedure for measuring and observing the relative amounts of smoke obscuration produced by the burning or decomposition of plastics. It is intended to be used for measuring the smoke-producing characteristics of plastics under controlled conditions of combustion or decomposition. Correlation with other fire conditions is not implied. The measurements are made in terms of the loss of light transmission through a collected volume of smoke produced under controlled, standardized conditions. The apparatus is constructed so that the flame and smoke can be observed during the test.²

1.2 **Warning**—During the course of combustion, gases or vapors, or both, are evolved that may be hazardous to personnel. Adequate precautions should be taken to protect the operator.

1.3 The values stated in SI units are to be regarded as the standard. The values given in parentheses are for information purposes only.

1.4 *This standard should be used to measure and describe the response of materials, products, or assemblies to heat and flame under controlled laboratory conditions and should not be used to describe or appraise the fire-hazard or fire-risk of materials, products, or assemblies under actual fire conditions. However, results of this test may be used as elements of a fire-hazard assessment or a fire risk assessment which takes into account all of the factors which are pertinent to an assessment of the fire hazard or fire-risk of a particular end use.*

1.5 *This standard does not purport to address all of the safety problems, if any, associated with its use. It is the responsibility of the user of this standard to establish appropriate safety and health practices and determine the applica-*

bility of regulatory limitations prior to use. Specific warning statements are given in 1.2 and 9.11.

NOTE 1—There is no similar or equivalent ISO standard.

2. Referenced Documents

2.1 ASTM Standards:

- D 618 Practice for Conditioning Plastics and Electrical Insulating Materials for Testing³
- D 883 Terminology Relating to Plastics³
- D 1600 Terminology for Abbreviated Terms Relating to Plastics³
- E 84 Test Method for Surface Burning Characteristics of Building Materials⁴
- E 176 Terminology Relating to Fire Standards⁴
- E 662 Test Method for Specific Optical Density of Smoke Generated by Solid Materials⁴
- E 691 Practice for Conducting an Interlaboratory Study to Determine the Precision of a Test Method⁵
- E 906 Test Method for Heat and Visible Smoke Release Rates for Materials and Products⁴
- E 1354 Test Method for Heat and Visible Smoke Release Rates for Materials and Products Using an Oxygen Consumption Colorimeter⁴

3. Terminology

3.1 **Definitions**—The terminology used in this test method is in accordance with Terminologies D 883 and D 1600 (terms relating to plastics) and Terminology E 176 (terms relating to fire).

4. Summary of Test Method

4.1 The test specimen is exposed to flame for the duration of the test, and the smoke is substantially trapped in the chamber in which combustion occurs. A 25 by 25 by 6-mm (1 by 1 by ¼-in.) specimen is placed on supporting metal screen and burned in a laboratory test chamber (Fig. 1) under active flame conditions using a propane burner operating at a pressure of

¹ This test method is under the jurisdiction of ASTM Committee D-20 on Plastics and is the direct responsibility of Subcommittee D20.30 on Thermal Properties (Section D20.30.03).

Current edition approved Dec. 10, 1999. Published March 2000. Originally published as D 2843 – 70. Last previous edition D 2843 – 93.

² Anonymous, "A Method of Measuring Smoke Density," *NFPA Quarterly*, QNFPA, Vol 57, January 1964, p. 276. Reprint NFPA Q57-9. Available from NFPA, 60 Batterymarch St., Boston, MA 02110.

³ *Annual Book of ASTM Standards*, Vol 08.01.

⁴ *Annual Book of ASTM Standards*, Vol 04.07.

⁵ *Annual Book of ASTM Standards*, Vol 14.02.

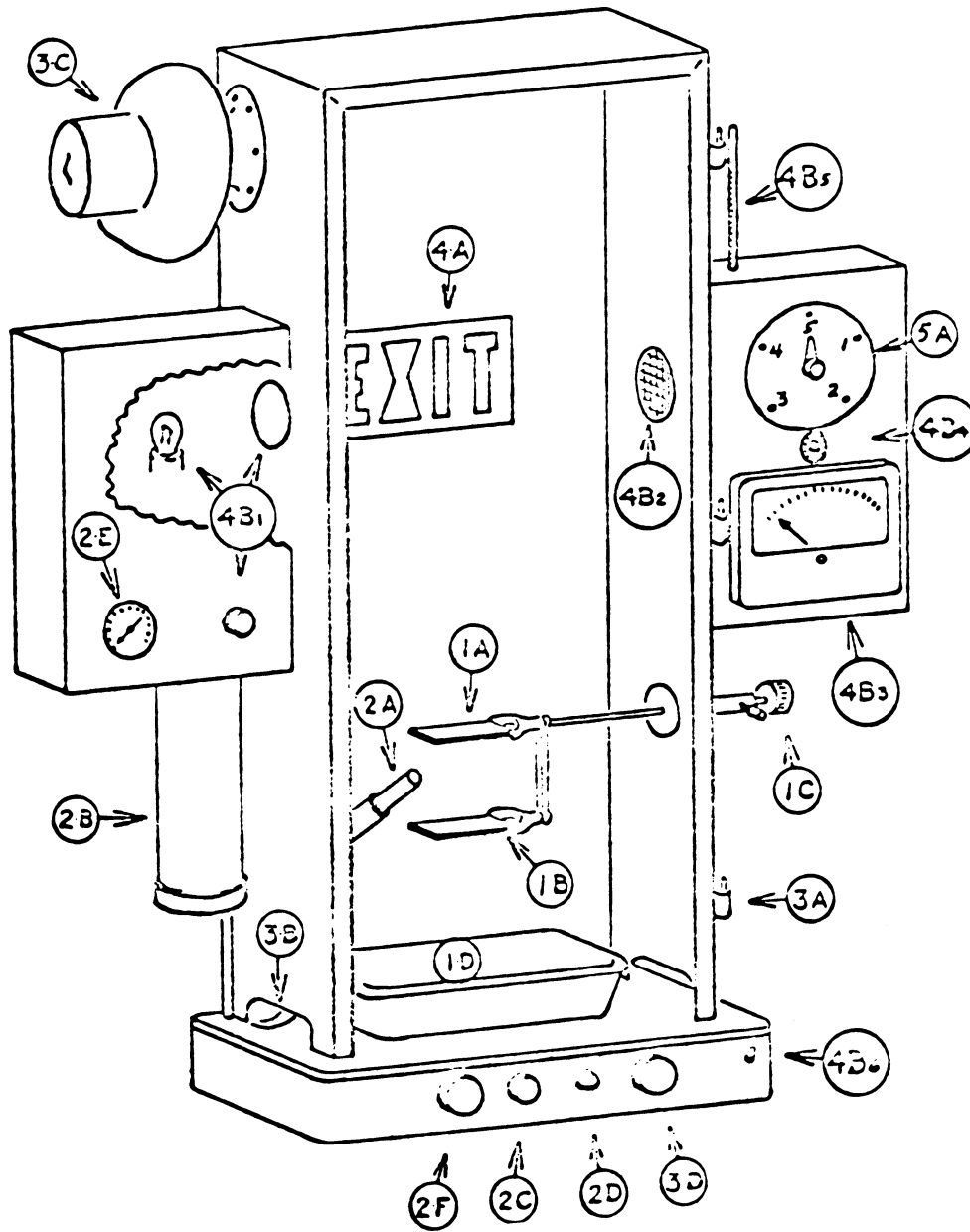

1. Specimen Holder
 - A Stainless steel screen
 - B Asbestos sheet
 - C Adjusting knob
 - D Quench pan
2. Ignition
 - A Burner
 - B Propane tank
 - C Gas shut-off valve
 - D Pressure regulator adjustment
 - E Pressure indicator
 - F Burner-positioning knob
3. Cabinet (shown without door)
 - A Hinges (door gasketed three sides)
 - B Vents (25-mm (1-in) high opening four sides)
 - C Blower (damper on mounting side)
 - D Control (blower on when damper is open)
4. Photometer
 - A Visual system (exit sign)
 - B Measuring system
 - 1 Light source and adjusting transformer
 - 2 Photronic cell and grid (to block stray light)
 - 3 Meter (indicating percent of light absorbed)
 - 4 Temperature compensation
 - 5 Photocell temperature monitor
 - 6 Range change
5. Timer
 - A Indicator, 0 to 5 min (friction reset)

FIG. 1 Schematic Diagram of Smoke Chamber

276 kPa (40 psi). The 300 by 300 by 790-mm (12 by 12 by 31-in.) test chamber is instrumented with a light source,

photoelectric cell, and meter to measure light absorption horizontally across the 300-mm (12-in.) light beam path. The

chamber is closed during the 4-min test period except for the 25-m (1-in.) high ventilation openings around the bottom.

4.2 The light-absorption data are plotted versus time. A typical plot is shown in Fig. 2. Two indexes are used to rate the material: the maximum smoke produced and the smoke-density rating.

5. Significance and Use

5.1 Tests made on a material under conditions herein prescribed can be of considerable value in comparing the relative smoke obscuration characteristics of plastics.

5.2 This test method serves to determine the extent to which plastic materials are likely to smoke under conditions of active burning and decomposition in the presence of flame.

NOTE 2—The visual and instrumental observations from this test compare well with the visual observations of the smoke generated by plastic materials when added to a freely burning large outdoor fire.⁶

5.3 The usefulness of this test procedure is in its ability to measure the amount of smoke obscuration produced in a simple, direct, and meaningful manner under the specified conditions. The degree of obscuration of vision by smoke generated by combustibles can be substantially affected by changes in quantity and form of material, humidity, draft, temperature, and oxygen supply.

6. Apparatus

6.1 The smoke chamber shall be constructed essentially as shown in Fig. 1.⁷

⁶ Bartosic, A. J., and Rarig, F. J., "Evaluation of the XP2 Smoke Density Chamber," *Symposium on Fire Test Methods—Restraint & Smoke*, ASTM STP 422, ASTM, Philadelphia, PA, 1966.

⁷ Detailed drawings of the smoke chamber are also available at a nominal cost from ASTM Headquarters. Order Adjunct : ADJD2843. A smoke chamber meeting the requirements of this test method is available from United States Testing Company, Inc., 1415 Park Ave., Hoboken, NJ 07030.

6.1.1 Chamber:

6.1.1.1 The chamber shall consist of a 14-gage (B & S) 300 by 300 by 790-mm (12 by 12 by 31-in.) aluminum box to which is hinged a heat-resistant glass glazed door. This box shall be mounted on a 350 by 400 by 57-mm (14 by 16 by 2¼-in.) base which houses the controls. Dependent upon the materials tested, the metal may require protection from corrosion.

6.1.1.2 The chamber shall be sealed except for 25 by 230-mm (1 by 9-in.) openings on the four sides of the bottom of the chamber. A1700-L/min (60-ft³/min) blower shall be mounted on one side of the chamber. The inlet duct to the blower shall be equipped with a close-fitting damper. The outlet of the blower shall be connected through a duct to the laboratory exhaust system. If the chamber is in a ventilated hood, no connection to the lab exhaust system through a duct is needed.

6.1.1.3 The two sides adjacent to the door shall be fitted with 70-mm (2¾ in.) diameter smoke-tight glazed areas centered 480 mm (19¾ in.) above the base. At these locations and outside the chamber, boxes containing the optical equipment and additional controls shall be attached.

6.1.1.4 A removable white plastic plate shall be attached to the back of the chamber. There shall be a 90 by 150-mm (3½ by 6-in.) clear area centered about 480 mm above the bottom of the chamber through which is seen an illuminated white-on-red exit sign. The white background permits observation of the flame, smoke, and burning characteristics of the material. The viewing of the exit sign helps to correlate visibility and measured values.

6.1.2 Specimen Holder:

6.1.2.1 The specimen shall be supported on a 64-mm (2½-in.) square of 6 by 6-mm, 0.9-mm gage (¼ by ¼-in., 0.035-in. gage) stainless steel wire cloth 220 mm (8¾ in.) above the base and equidistant from all sides of the chamber.

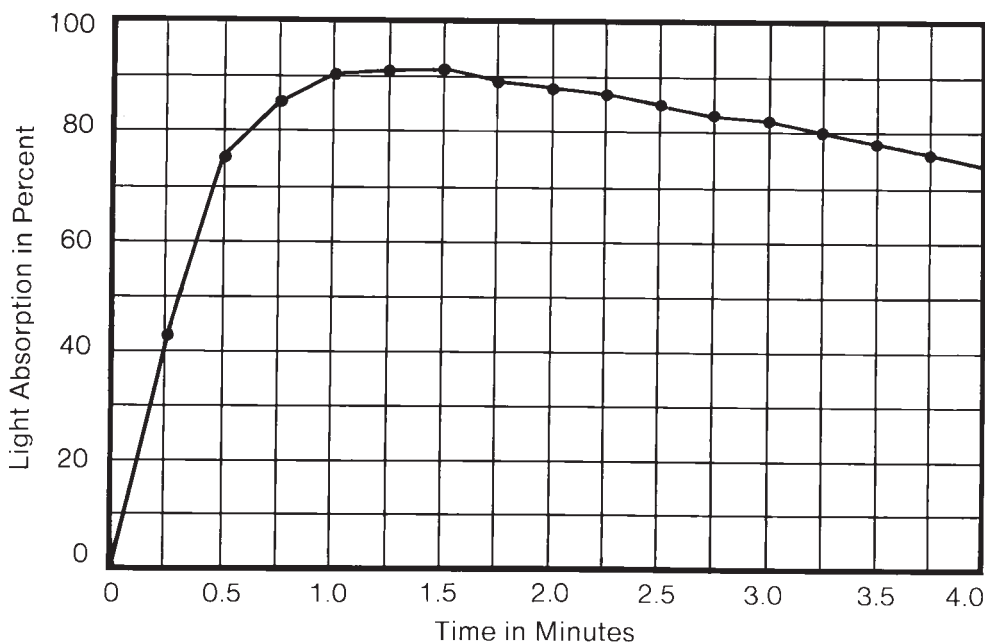

FIG. 2 Light Absorption versus Time

This screen shall lie in a stainless steel bezel supported by a rod through the right side of the chamber. From the same rod, a similar bezel shall be located 76 mm (3 in.) below, and it shall support a square of asbestos paper which catches any particles that may drip from the specimen during the test. By rotating the specimen holder rod, the burning specimen can be quenched in a shallow pan of water positioned below the specimen holder.

6.1.3 Ignition System:

6.1.3.1 The specimen shall be ignited by a propane flame from a burner operating at a pressure of 276 kPa (40 psi). The fuel (Note 3) shall be mixed with air which has been propelled through the burner by the venturi effect of the propane as it passes from a 0.13-mm (0.0005-in.) diameter orifice (Note 4), and the burner shall be assembled as shown in the exploded view of the burner in Fig. 3. The burner must be designed to provide adequate outside air.

NOTE 3—Commercial grade 85.0% minimum, gross heating value 23 000 cal/litre (2590 Btu/ft³) propane meets the requirements.

NOTE 4—Since the orifice provides the metering effect proportionate to the supply pressure, care must be taken that the orifice is the only means of fuel egress.

6.1.3.2 The burner shall be capable of being positioned quickly under the specimen so that the axis of the burner falls on a line passing through a point 8 mm (3/10 in.) above the base at one back corner of the chamber extending diagonally across the chamber and sloping upward at 45 deg with the base. The exit opening of the burner shall be 260 mm (10 1/4 in.) from the reference point at the rear of the chamber.

6.1.3.3 A duct at least 150 mm (6 in.) outside of the chamber shall provide the air piped to the burner.

6.1.3.4 Propane pressure shall be adjustable and preferably automatically regulated. Propane pressure shall be indicated by means of a Bourdon tube gage.

6.1.4 Photometric System:

6.1.4.1 A light source, a barrier-layer photoelectric cell, and a temperature compensated meter shall be used to measure the proportion of a light beam which penetrates a 300-mm (12-in.) path through the smoke. The light path shall be arranged horizontally as shown in Fig. 4.

6.1.4.2 The light source shall be mounted in a box (4B1 in Fig. 1) extending from the left side of the chamber at the mean height of 480 mm (19 3/4 in.) above the base. The light source shall be a compact filament microscope lamp No. 1493 operated at 5.8 V and a spherical reflector, with power supplied by a voltage-regulating transformer. A60 to 65-mm (2 1/2-in.) focal length lens shall focus a spot of light on the photocell in the right instrument panel.

6.1.4.3 Another box containing the photometer (4B2 in Fig. 1) shall be attached to the right side of the chamber. The barrier-layer photoelectric cell shall have standard observer spectral response. An egg-crate grid in front of the photocell shall be used to protect the cell from stray light. The grid shall be finished in dull black and have openings at least twice as deep as they are wide. The current produced by the photocell is indicated in terms of percent light absorption on a meter. The

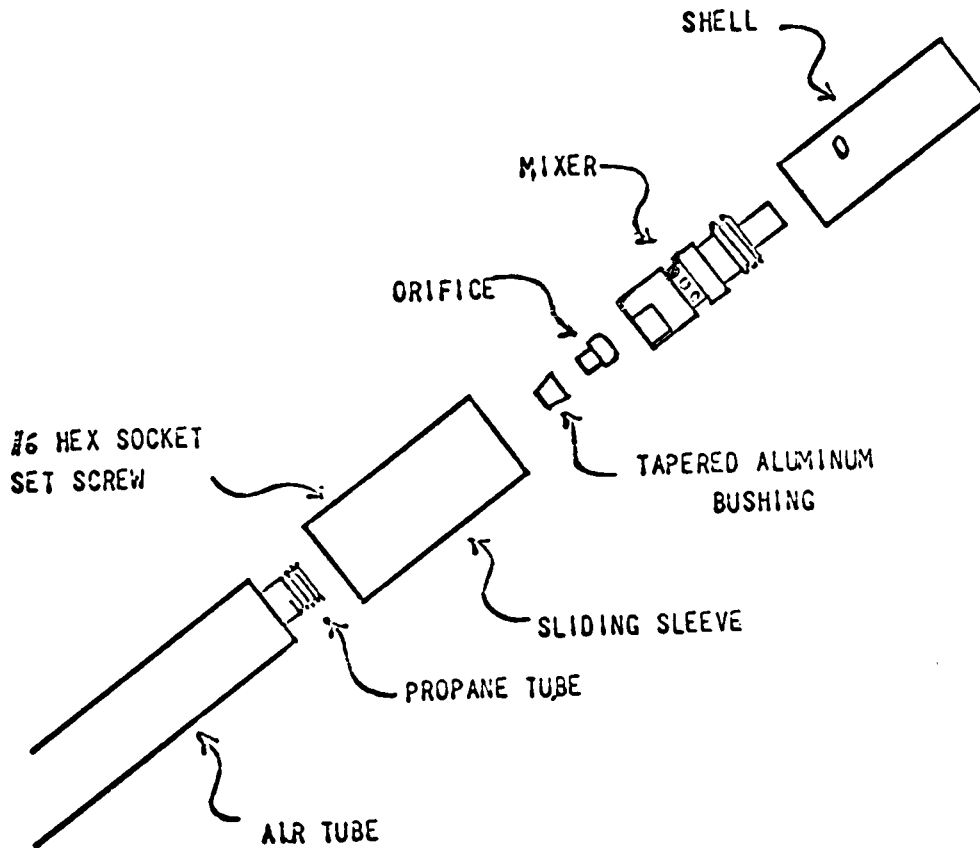
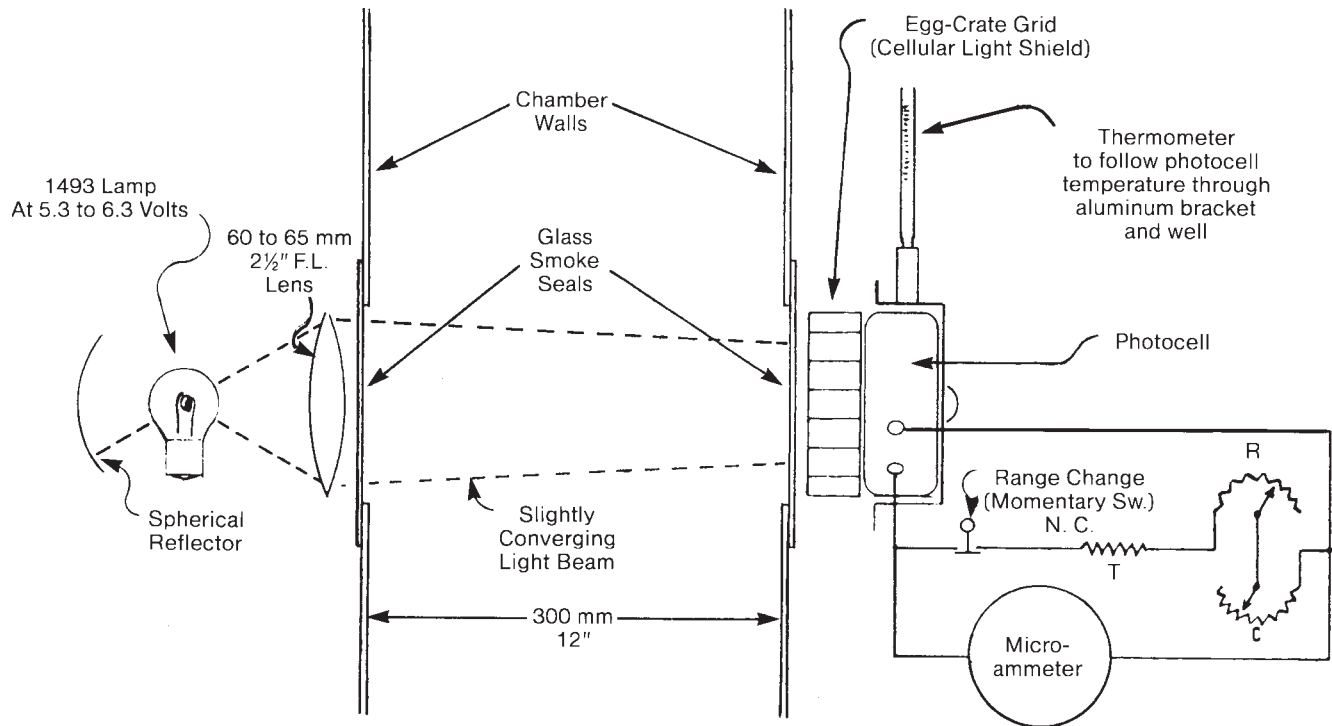

FIG. 3 Exploded View of Burner



T = Temperature-sensitive winding in or on meter case to increase in resistance in proportion to increase in meter resistance with temperature.
 R = Potentiometer with calibrated scale to reduce resistance in proportion to decrease in photocell output with rise in temperature.
 C = Potentiometer to calibrate total resistance of shunt to change meter sensitivity exactly by 10:1 ratio.

FIG. 4 Smoke Density Test Chamber Photometer

photocell linearity decreases as the temperature increases; compensations shall therefore be made.

NOTE 5—Photocell manufacturers recommend operating the photocell at temperatures not exceeding 50°C.

6.1.4.4 The meter shall have two ranges. The range change shall be accomplished by shunting the meter to one tenth of its sensitivity. When smoke accumulates to absorb 90 percent of the light beam, a momentary switch shall be depressed returning the meter to its basic sensitivity. By doing this the meter scale will then read from 90 to 100 % instead of 0 to 100 %.

6.1.5 *Timing Device*—A clock to indicate 15-s intervals shall be used. If the time intervals are audibly marked it will be convenient for the operator to record his observations. A clutch shall be used to reset the clock at the start of a test. The block shall be coupled to the burner-positioning device and it shall start when the burner is swung into test position.

6.1.6 *Planimeter*—A planimeter or other suitable means shall be used for measuring the area under the light-absorption curve.

7. Test Specimen

7.1 The standard specimen shall be 25.4 ± 0.3 by 25.4 ± 0.3 by 6.2 ± 0.3 mm (1 ± 0.01 by 1 ± 0.01 by $\frac{1}{4} \pm 0.01$ in.). Thicknesses other than 6.2 mm ($\frac{1}{4}$ in.) may be used and their size must be reported with the smoke density values (Note 6). Material thinner than 6.2 mm ($\frac{1}{4}$ in.) may be tested, either in its normal use thickness, or by stacking and forming a composite specimen approximately 6.2 mm ($\frac{1}{4}$ in.) thick. Material thicker than 6.2 mm ($\frac{1}{4}$ in.) may be tested either in its

normal use thickness or by machining the material down to a thickness of 6.2 mm ($\frac{1}{4}$ in.).

NOTE 6—If specimens other than the standard specimen are to be used, cooperating laboratories should agree upon preparation procedures and dimensions of the specimen. The results in such cases may vary from the results obtained with the standard specimen.

7.2 The specimens shall be sanded, machined, or die cut in a manner that produces a cut surface that is free from projecting fibers, chips, and ridges.

7.3 The test sample shall consist of three specimens.

8. Conditioning

8.1 *Conditioning*—Condition the test specimens at $23 \pm 2^\circ\text{C}$ ($73.4 \pm 3.6^\circ\text{F}$) and $50 \pm 5\%$ relative humidity for not less than 40 h prior to test in accordance with Procedure A of Practice D 618, for those tests where conditioning is required. In cases of disagreement, the tolerances shall be $\pm 1^\circ\text{C}$ ($\pm 1.8^\circ\text{F}$) and $\pm 2\%$ relative humidity.

8.2 *Test Conditions*—Conduct tests in the standard laboratory atmosphere of $23 \pm 2^\circ\text{C}$ ($73.4 \pm 3.6^\circ\text{F}$) and $50 \pm 5\%$ relative humidity, unless otherwise specified in the test methods or in this test method. In cases of disagreement, the tolerances shall be 1°C ($\pm 1.8^\circ\text{F}$) and $\pm 2\%$ relative humidity.

8.3 Tests shall be conducted in a hood that has a window for observing the test.

9. Standard Procedure

9.1 Turn on the photometer lamp, exit sign, and exhaust blower.

9.2 Turn on the propane, ignite the burner, and adjust the propane pressure to 276 kPa (40 psi). **Warning**—Do not fail to light the burner immediately.

9.3 Set the temperature compensation.

9.4 Adjust the lamp control to zero percent light absorption.

9.5 Lay the test specimen flat on the screen in such a position that the burner flame will be directly under the specimen when the burner is swung into position.

9.6 Set the timer to zero.

9.7 Shut off the exhaust blower, close the smoke chamber door, and immediately position the burner under the specimen and start the timer.

9.8 If in a hood, shut off the hood fan and close the hood door to within 50 mm (2 in.) of the bottom of the hood.

9.9 Record the percent light absorbed at 15-s intervals for 4 min.

9.10 Record observations during the conduct of the test. Include the time it takes for the sample to burst into flame, the time for flame extinguishment or specimen consumption, the obscuration of the exit sign by smoke accumulation, and any general or unusual burning characteristics noted such as melting, dripping, foaming, or charring.

9.11 Upon completion of the test, turn on the exhaust blower to ventilate the combustion products from the chamber. (**Warning**—It should be noted that for some materials the products of burning may be toxic, and care should be taken to guard the operator from the effects of these gases. The ventilating fan in the hood should be turned on and the damper opened immediately after the test is completed before opening the hood door in order to remove any irritating products of the test. The exhaust fan is turned off and the hood damper closed during the test to prevent back draft.)

9.12 Open the door and clean the combustion deposits from the photometer, exit sign, and door glass with detergent and water. Burn off any material remaining on the screen or replace the screen and asbestos square for the next test.

9.13 Run all tests in triplicate.

9.14 At the beginning of each series or at least once a day, check the light absorption of the meter against a calibrated neutral filter of approximately 50 % absorption. Check the 100 % absorption point against an opaque plate.

10. Special Procedure

10.1 For materials which drip excessively, a second or auxiliary burner (with separate propane gas supply) shall be introduced into the chamber. See Fig. 5 and auxiliary burner parts list.

10.2 The asbestos sheet (Item 1B of Fig. 1) shall be replaced with a stainless steel collector tray. This tray has a slight taper to permit the drippings to collect at the bottom. See item 11 of Fig. 5 and parts list for auxiliary burner.

10.3 The auxiliary burner shall be ignited at the same time the standard burner is ignited. The auxiliary burner shall be operated at 138 kPa (20 psi) and it shall be positioned in such a manner that its flame is directed at the center of the collector tray.

NOTE 7—It may be helpful to place a lightweight, about 1100 g (2.5 lbs), on the aluminum mounting plate (Item 12, Fig. 5) to prevent movement of the burner during the test.

10.4 In all other respects the procedures of Section 8 shall be followed.

11. Optional Procedures

11.1 The output of the photocell may be recorded versus time on an appropriate graphic recorder.

11.2 With a suitably sensitive meter, more than one decade change may be used to separate readings in the very dense smoke range.

12. Treatment of Data

12.1 Average the readings at 15-s intervals of light absorption for the three specimens in each group. Plot the average light absorption against time on linear paper. Fig. 2 is a sample curve.

12.2 Read the maximum smoke density as the highest point on the curve.

12.3 Determine the total smoke produced by measuring the area under the curve. The smoke density rating represents the total amount of smoke present in the chamber for the 4-min time interval. Measure the total smoke produced by the area under the curve of light absorption versus time, divided by the total area of the graph, 0-4 min 0-100 % light absorption, times 100.

NOTE 8—*Example*—In the light absorption-time plot in Fig. 2, the plot has been made using 10 mm (0.39 in.) equal to 10 % as the ordinate and 10 mm (0.39 in.) equal to 0.25 min as the abscissa. The graph area for 4 min is found to be 16 000 mm² (24.80 in.²). The area under the curve is found to be 12 610 mm² (19.55 in.²). The smoke density rating, %, is then computed as follows:

$$\begin{aligned} \text{Smoke density rating} &= (12610/16000 \times 100 = 78.8 \\ &\quad \text{(dimensions in millimetres)} \\ &= (19.55/24.80) \times 100 = 78.8 \\ &\quad \text{(dimensions in inches)} \end{aligned}$$

13. Report

13.1 Report the following information:

13.1.1 Identification of the material,

13.1.2 Dimensions of the specimen,

13.1.3 Readings of light absorption at 15-s intervals for each test and average,

13.1.4 Plots of average light absorption versus time,

13.1.5 Maximum smoke density in percent light absorption,

13.1.6 Area in percent under the light absorption-time curve (smoke density rating),

13.1.7 Observations on behavior of material,

13.1.8 Observations on obscurement of exit sign,

13.1.9 The details of any departure from the specifications of the method for testing, and

13.1.10 The caveat contained in 1.4 herein shall be incorporated in its entirety in the report issued.

14. Precision and Bias (Standard Procedure)⁸

14.1 Table 1 is based on a round robin completed in 1998 in accordance with Practice E 691, involving five materials tested

⁸ Supporting data are available from ASTM Headquarters. Request RR:D20-1203.

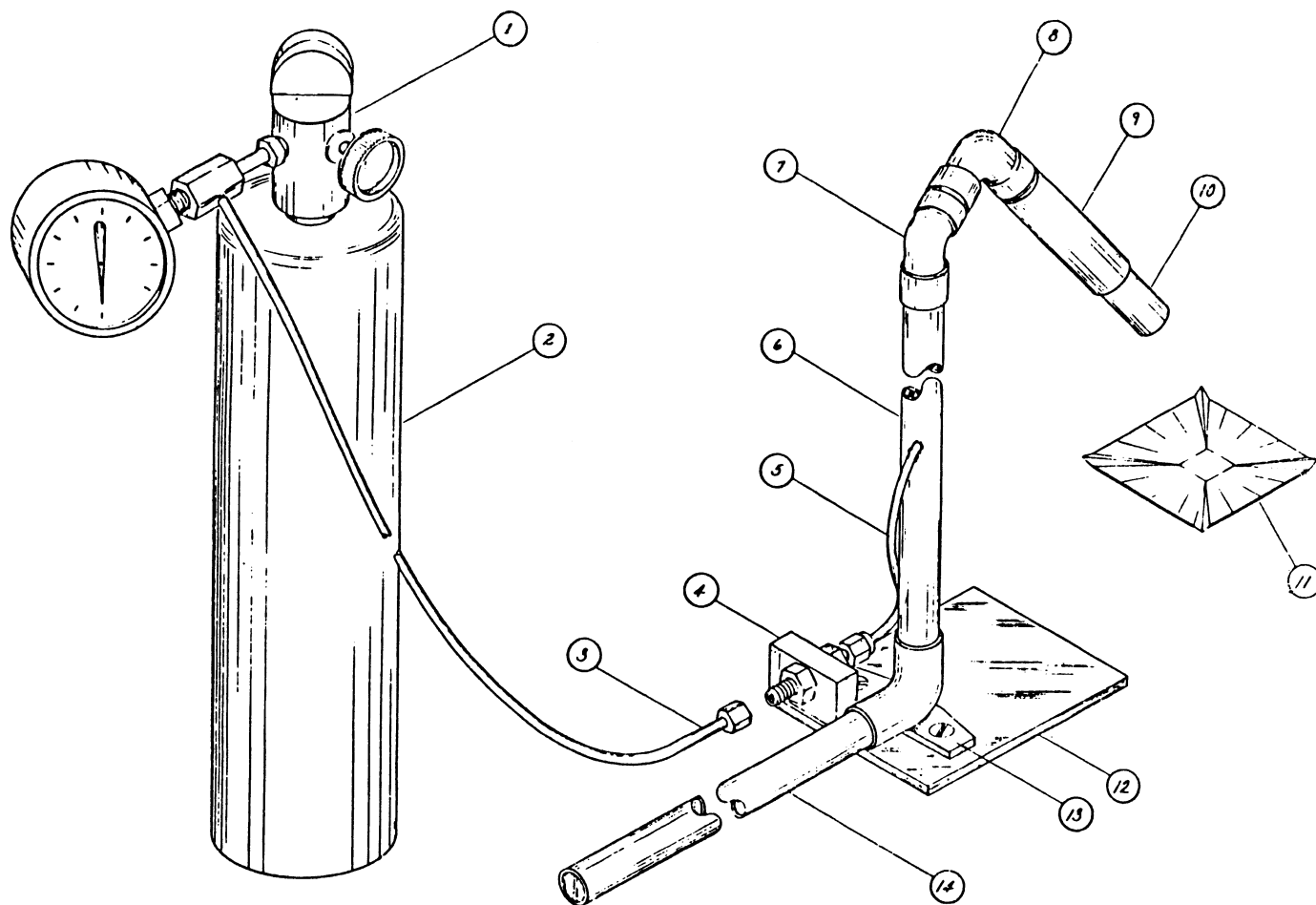

Auxiliary Burner Parts List

1. Low pressure propane gas regulator (0 to 60 psi gage).
2. Propane fuel tank.
3. Flexible gas line.
4. Aluminum support bracket.
5. 1/8 in. O.D. copper tube (flexible).
6. 1/2 in. diameter copper tube 8 in. long.
7. 45° extruded and expanded copper fitting.
8. 90° extruded and expanded copper fitting. (4 in. from bend to end of burner head)
9. Sliding sleeve.
10. Burner head. (Same as standard burner head)
11. S.S. collector tray (2 1/2 by 2 1/2 by 3/8 in. deep with 1/2 in. sq. bottom).
12. Aluminum mounting plate. (3 by 3 1/2 in.)
13. 90° elbow and wall flange. (copper)
14. 1/2 in. diameter copper tube 8 3/4 in. long.

FIG. 5 Auxiliary Burner

by six laboratories. For each material, all the samples were prepared at one source, but the individual specimens were prepared at the laboratories that tested them. Each test result was the average of three individual determinations.

14.1.1 It is important to note that the SRD rating can only be a whole number between the range of 0 and 100. Thus, values that are close to 100 such as material B and those close to 0 such as materials D and E may not have a normal distribution as is assumed in Practice E 691. The distribution would be skewed. If the standard deviation is applied to these numbers, the value range could exceed 100 or be less than 0. Practice E 691 does not allow for calculating values outside the normal

distribution. Thus, caution should be used in applying these statistics to numbers near the minimum and maximum of the test method.

14.2 **Warning**—The following explanations of I_r and I_R (14.3.1-14.3.3) are only intended to present a meaningful way of considering the *approximate* precision of this test method. The data in Table 1 should not be rigorously applied to acceptance or rejection of material, as those data are specific to the round robin and may not be representative of other lots, conditions, materials, or laboratories.

14.2.1 Users of this test method should apply the principles outlined in Practice E 691 to generate data specific to their

TABLE 1 Smoke Density Rating (SDR)

Material	Average, %	S_r^A	S_R^B	I_r^C	I_R^D
Polystyrene	90.0	1.94	4.16	5.44	11.64
General purpose polycarbonate	54.7	7.65	15.77	21.41	44.16
Abrasion resistant polycarbonate	44.5	7.00	22.55	19.61	63.13
Impact acrylic	6.1	2.25	6.78	6.29	18.98
PMMA copolymer	3.8	1.46	4.28	4.08	11.98

^A S_r = within-laboratory standard deviation for the indicated material. It is obtained by pooling the laboratory standard deviations of the test results from all of the participating laboratories:

$$S_r = [((S_1)^2 + (S_2)^2 \dots + (S_n)^2)/n]^{1/2}$$

^B S_R = between-laboratories reproducibility, expressed as standard deviation:

$$S_R = [S_r^2 + S_L^2]^{1/2}$$

^C I_r = within-laboratory critical interval between two test results = $2.8 \times S_r$.

^D I_R = between-laboratories critical interval between two test results = $2.8 \times S_R$.

laboratory and materials, or between specific laboratories. The principles of 14.3-14.3.3 would then be valid for such data.

14.3 *Concept of I_r and I_R* —If S_r and S_R have been calculated from a large enough body of data, and for test results that were averages from testing three specimens:

14.3.1 *I_r : Repeatability*—Comparing two test results for the same material, obtained by the same operator using the same equipment on the same day, the two test results should be judged not equivalent if they differ by more than the I_r value for that material.

14.3.2 *I_R : Reproducibility*—Comparing two test results for the same material, obtained by different operators using different equipment on different days, the two test results should be judged not equivalent if they differ by more than the I_R value for that material.

14.3.3 Any judgment per 14.3.1 and 14.3.2 would have an approximate 95 % (0.95) probability of being correct.

14.4 *Bias*—Bias is a systematic error which contributes to the difference between a test result and a true (or reference) value. There are no recognized standards by which to estimate bias of this test method.

15. Precision and Bias (Special Procedure)⁹

15.1 Table 2 is based on a round robin conducted in 1982

⁹ Supporting data are available from ASTM Headquarters. Request RR: D20-77.

per Practice E 691, involving nine materials tested by six laboratories. For each material, all the samples were prepared at one source, but the individual specimens were prepared at the laboratories which tested them. Each test result was the average of three individual determinations. Each lab obtained five test results for each material.

15.2 **Warning**—The following explanations of I_r and I_R (15.3.1-15.3.3) are only intended to present a meaningful way of considering the *approximate* precision of this test method. The data in Table 2 should not be rigorously applied to acceptance or rejection of material, as those data are specific to the round robin and may not be representative of other lots, conditions, materials, or laboratories.

15.2.1 Users of this test method should apply the principles outlined in Practice E 691 to generate data specific to their laboratory and materials, or between specific laboratories. The principles of 15.3-15.3.3 would then be valid for such data.

15.3 *Concept of I_r and I_R* —If S_r and S_R have been calculated from a large enough body of data, and for test results that were averages from testing three specimens:

15.3.1 *I_r : Repeatability*—Comparing two test results for the same material, obtained by the same operator using the same equipment on the same day, the two test results should be judged not equivalent if they differ by more than the I_r value for that material.

15.3.2 *I_R : Reproducibility*—Comparing two test results for the same material, obtained by different operators using different equipment on different days, the two test results should be judged not equivalent if they differ by more than the I_R value for that material.

15.3.3 Any judgment per 15.3.1 and 15.3.2 would have an approximate 95 % (0.95) probability of being correct.

15.4 *Bias*—Bias is a systematic error which contributes to the difference between a test result and a true (or reference) value. There are no recognized standards by which to estimate bias of this test method.

16. Keywords

16.1 burning; decomposition; plastics; smoke; smoke density; smoke development

TABLE 2 Precision Data for Special Procedure

Values in Units of Smoke Density Rating, Absolute %					
Material	Average	S_r^A	S_R^B	I_r^C	I_R^C
Molded polystyrene	88.00	2.90	3.72	8.22	10.55
Polystyrene sheet	81.90	3.61	5.26	10.21	14.89
PMMA	3.64	1.50	2.21	4.25	6.25
Polycarbonate	68.73	3.55	9.26	10.03	26.20
LDPE	63.53	4.30	9.24	12.17	26.15
HDPE	46.23	4.09	15.66	11.57	44.33
Modified HDPE	50.38	2.83	16.75	8.02	47.41
Molded acrylic	3.64	1.09	1.35	3.07	3.81
Impact modified acrylic	7.87	1.55	3.28	4.38	9.28

^A S_r = within-laboratory standard deviation of the average.

^B S_R = between-laboratories standard deviation of the average.

^C $I_r = 2.83 S_r$; $I_R = 2.83 S_R$.

APPENDIX

(Nonmandatory Information)

X1. ADDITIONAL INFORMATION

X1.1 Test Method D 2843 is used by model code organizations in controlling the use of plastic materials in light transmitting applications. It is allowed as an alternate to the Test Method E 84 smoke measurement since Test Method D 2843 can readily be performed on thermoplastic materials that may drip and fall out of the Test Method E 84 apparatus.

Thermoplastic materials comprise most of the plastics used in light transmitting applications. Many tests are available to measure smoke from burning materials (for example, Test Methods E 662, E 906, E 1354, and others). None of these tests, including Test Method D 2843, have shown any extensive correlation with each other.

SUMMARY OF CHANGES

This section identifies the location of selected changes to this test method. For the convenience of the user, Committee D-20 has highlighted those changes that may impact the use of this test method. This section may include descriptions of the changes or the reasons for the changes, or both.

D 2843-99:

(1) Added new precision and bias statements to Section 14.

ASTM International takes no position respecting the validity of any patent rights asserted in connection with any item mentioned in this standard. Users of this standard are expressly advised that determination of the validity of any such patent rights, and the risk of infringement of such rights, are entirely their own responsibility.

This standard is subject to revision at any time by the responsible technical committee and must be reviewed every five years and if not revised, either reapproved or withdrawn. Your comments are invited either for revision of this standard or for additional standards and should be addressed to ASTM International Headquarters. Your comments will receive careful consideration at a meeting of the responsible technical committee, which you may attend. If you feel that your comments have not received a fair hearing you should make your views known to the ASTM Committee on Standards, at the address shown below.

This standard is copyrighted by ASTM International, 100 Barr Harbor Drive, PO Box C700, West Conshohocken, PA 19428-2959, United States. Individual reprints (single or multiple copies) of this standard may be obtained by contacting ASTM at the above address or at 610-832-9585 (phone), 610-832-9555 (fax), or service@astm.org (e-mail); or through the ASTM website (www.astm.org).