



Designation: D 3014 – 99

Standard Test Method for Flame Height, Time of Burning, and Loss of Mass of Rigid Thermoset Cellular Plastics in a Vertical Position¹

This standard is issued under the fixed designation D 3014; the number immediately following the designation indicates the year of original adoption or, in the case of revision, the year of last revision. A number in parentheses indicates the year of last reapproval. A superscript epsilon (ϵ) indicates an editorial change since the last revision or reapproval.

This standard has been approved for use by agencies of the Department of Defense.

1. Scope *

1.1 This is a fire-test-response standard. This test method covers a small-scale laboratory screening procedure for comparing relative extent and time of burning and loss of mass of rigid thermoset cellular plastics. This test method should be used solely to establish relative burning characteristics and should not be considered or used as a fire-hazard classification.

1.1.1 This test method should not be used for materials that drip or melt under the test conditions.

1.2 During the course of combustion, gases or vapors, or both, are evolved which may be hazardous to personnel. Adequate precautions should be taken to protect the operator.

1.3 *This standard does not purport to address all of the safety concerns, if any, associated with its use. It is the responsibility of the user of this standard to establish appropriate safety and health practices and determine the applicability of regulatory limitations prior to use. A specific precautionary statement is given in 1.2.*

1.4 *This standard should be used to measure and describe the response of materials, products, or assemblies to heat and flame under controlled laboratory conditions and should not be used to describe or appraise the fire hazard or fire risk of materials, products, or assemblies under actual fire conditions. However, results of this test may be used as elements of a fire-hazard assessment or a fire-risk assessment which takes into account all of the factors which are pertinent to an assessment of the fire hazard or fire risk of a particular end use.*

NOTE 1—There is no similar or equivalent ISO standard.

2. Referenced Documents

2.1 ASTM Standards:

D 883 Terminology Relating to Plastics²

¹ This test method is under the jurisdiction of ASTM Committee D-20 on Plastics and is the direct responsibility of Subcommittee D20.30 on Thermal Properties (Section D20.30.03).

Current edition approved July 10, 1999. Published September 1999. Originally published as D 3014 – 73. Last previous edition D 3014 – 94.

² *Annual Book of ASTM Standards*, Vol 08.01.

D 1622 Test Method for Apparent Density of Rigid Cellular Plastics³

D 5025 Specification for Laboratory Burner Used for Small-Scale Burning Tests on Plastic Materials⁴

E 176 Terminology Relating to Fire Standards⁵

E 691 Practice for Conducting an Interlaboratory Study to Determine the Precision of a Test Method⁶

3. Terminology

3.1 *Definitions*—For terms relating to plastics, the definitions in this test method are in accordance with Terminology D 883. For terms relating to fire, the definitions in this test method are in accordance with Terminology E 176.

4. Summary of Test Method

4.1 The specimen is mounted in a vertical chimney with a glass front and ignited with a bunsen burner for 10 s. The height and duration of flame and the mass percent retained by the specimen are recorded.

5. Significance and Use

5.1 Tests made on rigid cellular materials in accordance with the conditions described by this test method can be of considerable value in comparing their burning characteristics. The height and duration of flame and the mass percent retained by the specimen are recorded.

5.2 This test method has been applied to flexible cellular materials and other plastics, but no detailed studies have been conducted to determine its general applicability to these materials.

5.3 In this procedure, the specimens are subjected to one or more specific sets of laboratory test conditions. If different test conditions are substituted or the end-use conditions are changed, it may not be possible by or from this test to predict changes in the fire-test-response characteristics measured. The

³ *Annual Book of ASTM Standards*, Vol 08.02.

⁴ *Annual Book of ASTM Standards*, Vol 08.03.

⁵ *Annual Book of ASTM Standards*, Vol 04.07.

⁶ *Annual Book of ASTM Standards*, Vol 14.02.

*A Summary of Changes section appears at the end of this standard.

results are therefore valid only for the fire-test-exposure conditions described in this procedure.

6. Apparatus

6.1 *Test Chimney*, conforming to the dimensions in Fig. 1, Fig. 2, and Fig. 3. The body of the chimney may be either galvanized or stainless steel. In it is fastened an insert made of 0.025-mm aluminum foil. The insert is held in place by a stainless steel channel that carries three pins to support the specimen. A heat-resistant glass panel forms the front wall of the chimney. A scale, in millimetres, graduated at 10-mm intervals shall be provided at one side of the glass panel for determining flame height (see Fig. 1 and Fig. 4). The scale shall begin 51 mm above the bottom of the chimney.

6.2 *Timer*, capable of measuring to the nearest 0.1 s for determining the duration of burning.

6.3 *Burner*—A standard gas burner with a 9.5-mm inside diameter barrel capable of producing a flame with an inner cone of 960°C is required to ignite the specimens. See Specification D 5025 for burner construction.

6.4 *Balance*, capable of weighing to the nearest 0.01 g for weighing the specimen.

6.5 *Test Chamber*—A relatively draft-free laboratory hood. The fan should be off during the test and should be turned on immediately following the test to remove products of combustion, which in some cases may be toxic.

7. Test Specimens

7.1 Cut six specimens from material of uniform density. The specimens shall be 254 by 19 by 19 mm and shall be free of dust, and the cut edges shall be smooth. If any specimen varies by more than 5 % from the average density of the six (see 9.1), the sample shall be considered unacceptable for testing by this test method.

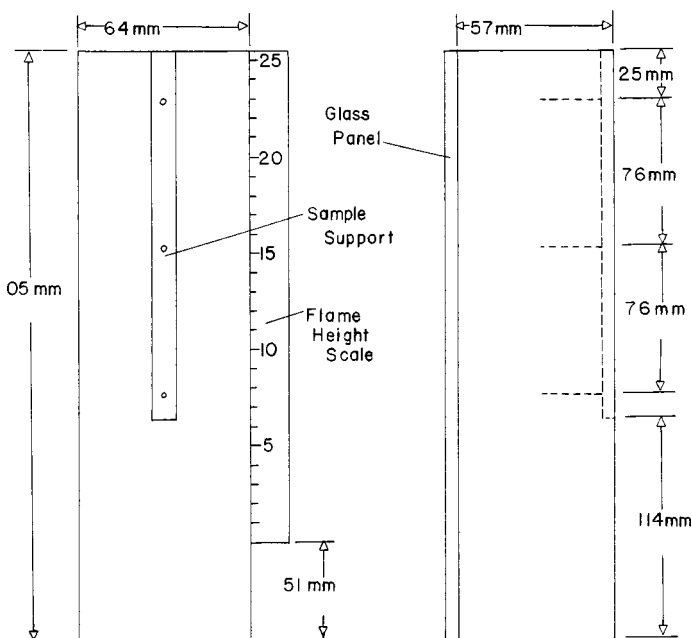

FIG. 1 Critical Dimensions of Chimney

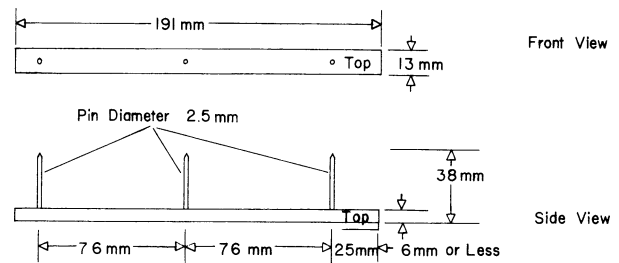

FIG. 2 Critical Dimensions of Specimen Support

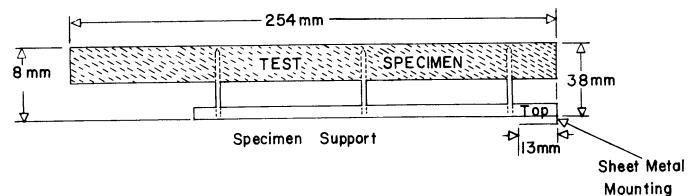

FIG. 3 Test Specimen Impaled on Specimen Support (Side View)

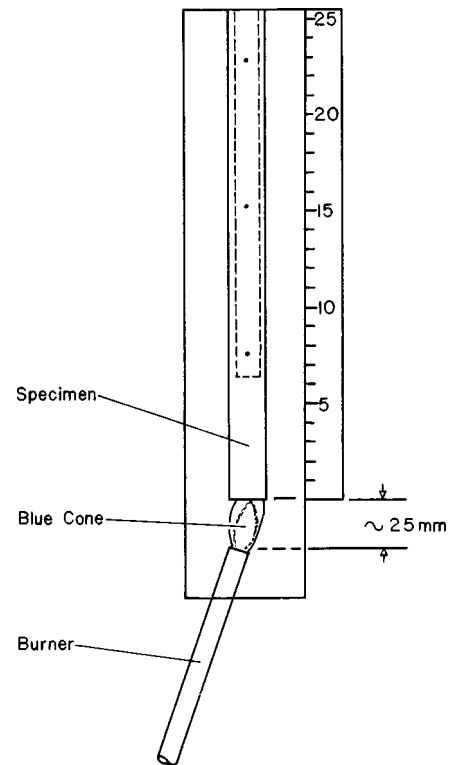

FIG. 4 Burner Position Under Specimen in Chimney (Front View)

8. Conditioning

8.1 Condition the specimens a minimum of 24 h at atmospheric conditions of 23 ± 2°C and 50 ± 5 % relative humidity.

8.2 The specimens shall remain in the temperature- and humidity-controlled atmosphere until immediately before testing.

9. Procedure

9.1 Determine the density of each specimen in accordance with Test Method D 1622.

9.2 Weigh and record the mass (M) of each specimen to the nearest 0.01 g.

9.3 Weigh and record the mass (S_1) of the specimen support to the nearest 0.01 g.

9.4 Ignite and adjust the burner so that the inner blue cone is 25 to 35 mm high. Further adjust the burner until the temperature at the top of the inner cone is $960 \pm 5^\circ\text{C}$.

NOTE 2—To obtain 960°C , it will be necessary to use a propane burner with propane gas, or a natural-gas burner with natural gas. In order to minimize the time and frequency required for temperature calibration, it is necessary to maintain a steady supply of gas. Thermocouples have been found useful to make this temperature measurement.

9.5 Impale the specimen on the three pins of the specimen support, with the top of the specimen even with the top of the specimen support as shown in Fig. 3. Higher-density cellular plastics may require that holes be drilled in the specimen to allow insertion of the pins. When required, the holes must be drilled at the time of specimen preparation. (If holes are drilled, the specimen shall be weighed after drilling holes, see 9.2.)

9.6 Line the chimney with aluminum foil so that it is against the sides and back of the chimney and flush with the bottom. Place the shiny side of the aluminum foil toward the test specimen. A new liner should be installed for each specimen.

9.7 Place the specimen support in the chimney so that the top of the specimen is even with the top of the chimney, as shown in Fig. 4.

9.8 Put the glass front in place and ignite the specimen by placing the inner cone of the burner flame under the center of the specimen for 10 s. Simultaneous with placing the flame under the specimen, start the timer to determine the time to extinguishment (T_3). Keep the burner at an angle of about 15° from the vertical as shown in Fig. 4.

NOTE 3—Accurate positioning of the burner is facilitated by use of a cradle to hold the burner at the proper angle and distance from the specimen.

9.9 Measure the maximum flame height (H), during combustion of the specimen, to the nearest 10 mm with the flame-height scale on the front of the chimney and record the height. If the flame rises above the top of the scale, record as $250 + \text{mm}$.

9.10 Stop the timer when combustion of the specimen ceases and record as time to extinguishment (T_e) to the nearest second. If the time to extinguishment is less than 10 s, note the time but continue to apply the flame for 10 s.

9.11 After cooling, remove the specimen support and specimen and weigh, without removing the specimen, to the nearest 0.01 g, and record (S_2).

9.12 Clean the specimen support and repeat 9.5-9.11 until all specimens have been ignited.

10. Symbols

10.1 Symbols are identified as follow:

- H = maximum flame height during combustion, mm.
 T_e = time between application of burner flame and specimen flame extinguishment, s. Afterglow shall not be included in this time.

- S_1 = mass of the specimen support, g.
 M = mass of the specimen, g.
 S_2 = mass of specimen and specimen support after ignition, g.
 PMR = percent mass retained by entire specimen.

11. Calculation

11.1 Calculate the mass percent of the specimen retained after ignition by the equation:

$$PMR = [(S_2 - S_1)/M] \times 100 \quad (1)$$

12. Report

12.1 Report the following information:

12.1.1 A description of the material, including type of plastic or trade name, date of manufacture, manufacturer's lot number, or other identifying information,

12.1.2 Average density,

12.1.3 Average time to extinguishment for the six specimens to the nearest second,

12.1.4 Number of specimens that produced flaming drips,

12.1.5 Average mass percent retained for the six specimens,

12.1.6 Average flame height for the six specimens to the nearest 25 mm,

12.1.7 Air temperature and relative humidity during storage prior to conditioning and storage time, and

12.1.8 Air temperature and relative humidity during flame testing.

13. Precision and Bias ⁷

13.1 Table 1, Table 2, and Table 3 are based on a round robin completed in 1988 in accordance with Practice E 691, involving seven materials tested by six laboratories. The materials included one phenolic (Material No. 1) and six polyurethanes (Material Nos. 2–7). Each test result was the average of six individual determinations. Each laboratory obtained five test results for each material.

NOTE 4—**Caution:** The explanations of r and R given in 13.2-13.2.3 are only intended to present a meaningful way of considering the approximate precision of this test method. The data in Table 1, Table 2, and Table 3 should not be rigorously applied to acceptance or rejection of material, as those data are specific to the round robin and may not be representative of other lots, conditions, materials, or laboratories.

⁷ Supporting data are available from ASTM Headquarters. Request RR: D20-1159.

TABLE 1 Average Mass Percent Retained

Material	Mass Retained, %				
	Average	s_r	s_R	r	R
4	18.11	3.09	5.25	8.65	14.70
6	24.33	2.34	2.65	6.55	7.42
5	74.13	2.39	3.06	6.69	8.57
3	74.25	2.26	2.67	6.33	7.48
2	75.57	1.26	3.26	3.53	9.13
7	75.62	1.46	2.43	4.09	6.80
1	95.03	1.40	2.33	3.92	6.52

TABLE 2 Average Time to Extinguishment

Material	Time to Extinguishment, s				
	Average	s_r	s_R	r	R
1	9.04	0.58	2.50	1.62	7.00
3	11.05	0.46	0.52	1.29	1.46
7	11.13	0.48	0.58	1.34	1.62
5	11.47	0.36	0.40	1.01	1.12
2	12.12	0.63	1.12	1.76	3.14
6	17.20	1.31	2.30	3.67	6.44
4	24.07	3.11	4.75	8.71	13.30

TABLE 3 Average Flame Height

Material	Flame Height, cm				
	Average	s_r	s_R	r	R
1	15.59	0.58	5.54	1.62	15.51
2	22.69	0.63	2.04	1.76	5.71
3	22.77	0.46	2.35	1.29	6.58
5	23.26	0.36	1.71	1.01	4.79
4	25.00	3.11	3.11	8.71	8.71
6	25.00	1.31	1.31	3.67	3.67
7	26.60	0.48	3.05	1.34	8.54

s_r = within-laboratory standard deviation of the average,
 s_R = between-laboratories standard deviation of the average,
 $r = 2.8 s_r$, and
 $R = 2.8 s_R$.

13.1.1 Users of this test method should apply the principles outlined in Practice E 691 to generate data specific to their laboratory and materials, or between specific laboratories. The principles in 13.2-13.2.3 would then be valid for such data.

13.2 *Concept of r and R* —If s_r and s_R have been calculated from a large enough body of data, and for test results that were averages from testing six specimens, the following applies:

13.2.1 *Repeatability, r* —In comparing two test results for the same material, obtained by the same operator using the same equipment on the same day, the two test results should be judged not equivalent if they differ by more than the r value for that material.

13.2.2 *Reproducibility, R* —In comparing two test results for the same material, obtained by different operators using different equipment on different days, the two test results should be judged not equivalent if they differ by more than the R value for that material.

13.2.3 Any judgment in accordance with 13.2.1 and 13.2.2 would have an approximate 95 % probability of being correct.

13.3 *Bias*—There are no recognized standards on which to base an estimate of bias for this test method.

14. Keywords

14.1 cellular plastics; flame height; flammability; mass loss; time of burning; vertical position

SUMMARY OF CHANGES

This section identifies the location of selected changes to this test method. For the convenience of the user, Committee D-20 has highlighted those changes that may impact the use of this test method. This section may also include descriptions of the changes or reasons for the changes, or both.

D 3014 – 99:

(I) Removed Footnote 6 and renumbered remaining footnotes.

ASTM International takes no position respecting the validity of any patent rights asserted in connection with any item mentioned in this standard. Users of this standard are expressly advised that determination of the validity of any such patent rights, and the risk of infringement of such rights, are entirely their own responsibility.

This standard is subject to revision at any time by the responsible technical committee and must be reviewed every five years and if not revised, either reapproved or withdrawn. Your comments are invited either for revision of this standard or for additional standards and should be addressed to ASTM International Headquarters. Your comments will receive careful consideration at a meeting of the responsible technical committee, which you may attend. If you feel that your comments have not received a fair hearing you should make your views known to the ASTM Committee on Standards, at the address shown below.



D 3014

This standard is copyrighted by ASTM International, 100 Barr Harbor Drive, PO Box C700, West Conshohocken, PA 19428-2959, United States. Individual reprints (single or multiple copies) of this standard may be obtained by contacting ASTM at the above address or at 610-832-9585 (phone), 610-832-9555 (fax), or service@astm.org (e-mail); or through the ASTM website (www.astm.org).