



Designation: D 3159 – 9804

## Standard Specification for Modified ETFE-Fluoropolymer Molding and Extrusion Materials<sup>1</sup>

This standard is issued under the fixed designation D 3159; the number immediately following the designation indicates the year of original adoption or, in the case of revision, the year of last revision. A number in parentheses indicates the year of last reapproval. A superscript epsilon (ε) indicates an editorial change since the last revision or reapproval.

*This standard has been approved for use by agencies of the Department of Defense.*

### 1. Scope\*

1.1 This specification covers melt processible molding and extrusion materials of modified ETFE-fluoropolymer. The ETFE resin is a copolymer of ethylene containing approximately 75 mass % of tetrafluoroethylene.

1.2 The values stated in SI units as detailed in IEEE/ASTM SI-10 are to be regarded as the standard. The values given in parentheses ~~brackets~~ are for information only.

NOTE 1—Although this specification and ISO 12086-1 (1994) and ISO 12086-2 (1994) differ in approach or detail, data obtained using either are technically equivalent.

1.3 The following safety hazards caveat pertains only to the test method portion, Section 11, of this specification. *This standard does not purport to address all of the safety concerns, if any, associated with its use. It is the responsibility of the user of this standard to establish appropriate safety and health practices and determine the applicability of regulatory limitations prior to use.*

1.4 Recycled material is not appropriate for this specification because performance requirements cannot be met with recycled material. Therefore, this specification is for virgin material only.

### 2. Referenced Documents

2.1 *ASTM Standards:*<sup>2</sup>

<sup>1</sup> This specification is under the jurisdiction of ASTM Committee D-20 on Plastics and is the direct responsibility of Subcommittee D20.15 on Thermoplastic Materials (Section D20.15.12).

Current edition approved Nov. 10, 1998. Published February 1999. ~~1, 2004. Published March 2004. Originally published as D 3159 - 73; approved in 1973. Last previous edition D 3159 - 95a.~~  
This edition was modified approved in 1-998 as D 3159 - 98.

\*A Summary of Changes section appears at the end of this standard.

D 150 Test Methods for A-C Loss Characteristics and Permittivity (Dielectric Constant) of Solid Electrical Insulating Materials<sup>2</sup>  
Insulation

D 618 Practice for Conditioning Plastics and Electrical Insulating Materials for Testing

D 638 Test Method for Tensile Properties of Plastics

D 792 Test Methods for Density and Specific Gravity (Relative Density) and Density of Plastics by Displacement

D 883 Terminology Relating to Plastics

D 1238 Test Method for Melt Flow Rates of Thermoplastics by Extrusion Plastometer

D 1600 Terminology for Abbreviated Terms Relating to Plastics

D 3418 Test Method for Transition Temperatures of Polymers by Thermal Analysis<sup>3</sup> Differential Scanning Calorimetry

D 3892 Practice for Packaging/Packing of Plastics

E 177 Practice for Use of the Terms Precision and Bias in ASTM Test Methods

SI 10 Use of the International System of Units (SI): The Modern Metric System

2.2 ISO Standards:

ISO 12086-1 (1994) Plastics—Fluoropolymer Dispersions and Moulding and Extrusion Materials—Part 1

ISO 12086-2 (1994) Plastics—Fluoropolymer Dispersions and Moulding and Extrusion Materials—Part 2

### 3. Terminology

3.1 Definitions:

3.1.1 *General*—The terminology given in Terminology D 883 is applicable to this specification.

3.1.2 *lot, n*—one production run or a uniform blend of two or more production runs.

3.1.3 *Abbreviated Terms*:

3.1.4 *General*—The abbreviated terms given in Terminology D 1600 are applicable to this specification.

### 4. Classification

4.1 This specification covers ~~three~~ four types of modified ETFE-fluoropolymer supplied in pellet form classified according to their specific gravity. The resins of each type are divided into ~~two~~ one to three grades according to their melt flow rate.

4.2 An one-line system ~~may~~ shall be used to specify materials covered by this specification. The system uses predefined cells to refer to specific aspects of this specification, as illustrated as follows:

<sup>2</sup> For referenced ASTM standards, visit the ASTM website, [www.astm.org](http://www.astm.org), or contact ASTM Customer Service at [service@astm.org](mailto:service@astm.org). For *Annual Book of ASTM Standards*, Vol 10.01, volume information, refer to the standard's Document Summary page on the ASTM website.

*Annual Book of ASTM Standards*, Vol 08.02.

<sup>3</sup> "Stellite" Grade No. 19, Haynes-Stellite Co., Kokomo, IN, and "Duranickel" No. 301, International Nickel Co., 67 Wall St., New York, NY 10005, have been found resistant to fluorocarbon resins.

Specification

Standard Number : Type : Grade : Special  
Block : : : Notes

Example: Specification D 3159 – 95, I 2

For this example, the line callout would be, Specification D 3159 – 95,I2 and would specify a modified ETFE-fluoropolymer that has all of the properties listed for that type and grade in the appropriate specified properties, or tables, or both, in the specification identified. A comma is used as the separator between the standard number and the type. Separators are not needed between the type and grade.<sup>4</sup> Provision for special notes is included so that other information can be provided when required. An example would be in Specification D 3295 where dimensions and tolerances are specified for each AWG size within the type and class. When special notes are used, they ~~should~~ shall be preceded by a comma.

**TABLE 1 Specific Gravity, Melting Point, and Flow Rate Requirements**

Type Grade	I			II		III		IV
	1 <sup>A</sup>	2 <sup>B</sup>	3	1	2	1	2	1
Specific gravity,								
—min:	1.69	1.69		1.75	1.75	1.83	1.83	
min:	1.69	1.69	1.69	1.75	1.75	1.83	1.83	1.74
—max:	1.76	1.76		1.84	1.84	1.88	1.88	
max:	1.76	1.76	1.76	1.84	1.84	1.88	1.88	1.78
Melting point, °C,								
—min:	255	255		220	220	220	220	
min:	255	255	250	220	220	220	220	220
—max:	280	280		255	255	230	230	
max:	280	280	280	255	255	230	230	240
Flow rate, g/10 min,								
—min:	2.0	8.0 <sup>C</sup>		2.0	10.1	9.0	25.0	
min:	2.0	8.0	25	2.0	10.1	9.0	25.0	10
—max:	16.0	28.0 <sup>C</sup>		10.0	19.0	18.0	35.0	40
max:	16.0	28.0 <sup>A</sup>	45	10.0	19.0	18.0	35.0	40

<sup>A</sup>Formerly Types I and II.

<sup>B</sup>Formerly Type III.

<sup>C</sup>Measured with 1.588-mm (0.0625-in.) orifice; other values measured with 2.095-mm (0.0825-in.) orifice.

**TABLE 2 Detail Requirements for Molded Test Specimens for All Resins in This Specification**

Type Grade	I			II		III		IV
	1	2	3	1	2	1	2	1
Tensile strength, min, psi:	5500	4400		4500	4500	4000	4000	
Tensile strength, min, psi:	5500	4400	5500	4500	4500	4000	4000	5000
Elongation, min, %:	275	200		300	300	350	350	
Elongation, min, %:	275	200	300	300	300	350	350	350
Dielectric constant,								
—10 <sup>3</sup> Hz, max:	2.6	2.6		2.6	2.6	2.6	2.6	
10 <sup>3</sup> Hz, max:	2.6	2.6	2.6	2.6	2.6	2.6	2.6	2.6
—10 <sup>6</sup> Hz, max:	2.7	2.7		2.7	2.7	2.7	2.7	
10 <sup>6</sup> Hz, max:	2.7	2.7	2.7	2.7	2.7	2.7	2.7	2.7
Dissipation factor,								
—10 <sup>3</sup> Hz, max:	0.0008	0.0008		0.003	0.003	0.0008	0.0008	
10 <sup>3</sup> Hz, max:	0.0008	0.0008	0.0008	0.0008	0.0008	0.0008	0.0008	0.0008
—10 <sup>6</sup> Hz, max:	0.009	0.009		0.009	0.009	0.009	0.009	
10 <sup>6</sup> Hz, max:	0.009	0.009	0.009	0.009	0.009	0.009	0.009	0.009

**5. General Requirements**

5.1 The material shall be of uniform composition and so prepared as to conform to the requirements of this specification.

5.2 The material described in this specification shall be free of foreign matter to such a contamination level as ~~may~~ shall be agreed upon between the purchaser and the seller.

<sup>4</sup> See the ASTM Standards, Vol 08.01, *Form and Style Manual*, available from ASTM Headquarters.

## 6. Performance Requirements

6.1 The average test result of the lot shall conform to the requirements prescribed in Tables 1 and 2 when tested by the procedures specified herein. Table 2 lists those tests requiring a specimen molded as described in Section 8.

## 7. Sampling

7.1 The materials shall be sampled in accordance with an adequate statistical sampling program.

## 8. Specimen Preparation

8.1 Prepare a molded sheet  $1.5 \pm 0.3$  mm ( $[0.06 \pm 0.01$  in.]) thick. Use a picture-frame-type chase having a suitable blanked-out section and thickness to produce the desired sheet. Use clean aluminum foil, 0.13 to 0.18 mm ( $[0.005$  to  $0.007$  in.]) thick, in contact with the resin. A high-temperature mold release agent may be sprayed on the aluminum foil to help prevent the foil from sticking to the sheet. Use steel molding plates at least 1.0 mm ( $[0.040$  in.]) thick and of an area adequate to cover the chase.

8.2 Lay down and smoothly cover one plate with a sheet of aluminum foil. Place the mold chase on top of this assembly. Place within the mold chase sufficient molding material to produce the required sheet in such manner that the polymer charge is a mound in the middle of the chase. Place a second sheet of aluminum foil on top of the granules and add the top mold plate. Place the assembly in a compression molding press having platens that have been heated to  $300 \pm 5^\circ\text{C}$  ( $[572 \pm 10^\circ\text{F}]$ ).

8.3 Bring the press platens to incipient contact with the mold assembly. Hold for 2 to 4 min without pressure. Apply approximately 1 MPa ( $[145$  psi]) and hold for 1 to 1.5 min. Then apply 2 to 4 MPa ( $[290$  to  $580$  psi]) and hold for 1 to 1.5 min. Maintain the press at  $300 \pm 5^\circ\text{C}$  ( $[572 \pm 10^\circ\text{F}]$ ) during these steps. Remove the assembly from the press and place between two  $20 \pm 7$ -mm ( $[0.75 \pm 0.25$ -in.]) steel plates whose temperature is less than  $40^\circ\text{C}$  ( $[104^\circ\text{F}]$ ).

8.4 When the sheet is cool enough to touch (about  $50$  to  $60^\circ\text{C}$  ( $[122$  to  $140^\circ\text{F}]$ )), remove aluminum foil from the sheet. (If the sheet is allowed to cool to room temperature, the aluminum foil cannot be pulled free.)

## 9. Conditioning

9.1 For tests of specific gravity, tensile properties, and electrical properties, condition the molded test specimen in accordance with Practice D 618, Condition 4/23/50. The other tests require no conditioning.

9.2 Conduct tests at the standard laboratory temperature of  $23 \pm 2^\circ\text{C}$  ( $[73.4 \pm 3.6^\circ\text{F}]$ ) for determination of specific gravity, tensile properties, and electrical properties only. Since the resin does not absorb water, the maintenance of constant humidity during testing is not necessary. Conduct tests for flow rate and melting endotherm under ordinary laboratory conditions.

## 10. Packaging and Marking

10.1 *Packaging*—The material shall be packaged in standard commercial containers so constructed as to ensure acceptance by common or other carriers for safe transportation to the point of delivery unless otherwise specified in the contract or order.

10.2 *Marking*—Shipping containers shall be marked with the name of the material, type, and quantity therein.

10.3 All packing, packaging, and marking provisions of Practice D 3892 shall apply to this specification.

## 11. Test Methods

### 11.1 *Melt Flow Rate:*

11.1.1 *Principle of Test Method*—Determine the flow rate at  $297 \pm 1^\circ\text{C}$  using Procedure A or B or Test Method D 1238. Use the extrusion plastometer described in Test Method D 1238 and modified in accordance with 11.1.2. The sample ~~may~~ shall be pellets or pieces of approximately the same suitable size cut from molded or extruded forms. Strips about 6 mm wide by 76 mm long ( $[0.25$  by  $3$ -in.) ~~may~~ in.] shall be conveniently handled. See Table 2 or 3 of Test Method D 1238 for the amount of charge that ~~should~~ shall be adjusted accordingly with the melt density of ETFE being used. Usually the charge amount is 5 to 15 g. Measure the flow rate using a load of 49 N for Types I, II, and III. Collect four successive cuts for the manual method.

11.1.2 *Apparatus*—The apparatus shall consist of an extrusion plastometer, described in Test Method D 1238, modified by use of corrosion-resistant<sup>3</sup> alloy for the barrel lining, orifice, piston tip, and orifice securing device.<sup>6</sup> The orifice diameter is 2.095 by 8.000 mm long ( $[0.0825$  by  $0.315$  in.]) for all types except 1.588 by 6.070 mm ( $[0.0625$  by  $0.239$  in.]) for Type I, Grade 2.

### 11.1.3 *Procedure:*

11.1.3.1 *Temperature Calibration*—The specified melt temperature of  $297 \pm 1^\circ\text{C}$  is the temperature measured in the melt 13 mm ( $[0.5$  in.]) above the orifice. This temperature ~~may~~ shall be obtained by controlling the temperature measured in the thermometer well at approximately  $305^\circ\text{C}$ . Prior to making a test, set the plastometer temperature as follows: With the orifice in place, insert a standardized thermocouple (Note 2) through the orifice from the bottom of the plastometer to a point 13 mm ( $[0.5$  in.]) above the top of the orifice. Charge 5 g of resin granules to the plastometer, compact with the piston, and wait  $10 \pm 0.5$  min

## *Annual Book of ASTM Standards, Vol 14.02.*

<sup>6</sup> Suitable instruments are available commercially from the F. F. Slocomb Corp., 1400 Poplar St., Wilmington, DE 19899; Tinius Olsen Testing Machine Co., 2020 Easton Rd., Willow Grove, PA 19090; and D & R Plastic Welders, Inc., Box J, Hazardville, CT 06036.

for the melt temperature to reach equilibrium. Make the necessary adjustment in the temperature controller to bring the melt temperature to  $297 \pm 1^\circ\text{C}$ . Repeat this calibration procedure and record the temperature versus time at 1-min intervals for the first 10 min. The polymer ~~should~~ shall reach the  $297^\circ\text{C}$  temperature within 5 min. With polymer in the plastometer for an elapsed time of 10 min for each point measured, determine the melt temperature at 6.4-mm-~~(~~[0.25-in.~~)]~~ intervals from 6.4 mm to 51 mm-~~(~~[2 in.~~)]~~ above the orifice. The entire temperature profile ~~should~~ shall be within a range of  $2^\circ\text{C}$ . This precision is readily obtained by proper insulation of the sides, bottom, and top of the plastometer.

NOTE 2—Suitable standards for thermocouple calibration are: lead, m.p.  $327.5^\circ\text{C}$ , potassium dichromate, m.p.  $398.0^\circ\text{C}$ , and zinc, m.p.  $419.4^\circ\text{C}$ .

11.1.4 *Precision and Bias*—Precision and bias for this test method are to be determined by round-robin testing.

11.2 *Specific Gravity*—Determine the specific gravity of a specimen approximately 25 by 38 mm-~~(~~[1 by 1.5 in.~~)]~~ blanked or cut from the molded plaque (see Section 8) in accordance with the procedures described in Test Methods D 792. Add 2 drops of a wetting agent to the water in order to reduce the surface tension and ensure complete wetting of the specimen.

11.3 *Melting Endotherm Peak Temperature* :

11.3.1 Determine the endotherm melting peak with a differential thermal analyzer (DTA) or with a differential scanning calorimeter (DSC) operated in a DTA mode at  $10^\circ\text{C}/\text{min}$ -~~(~~[ $18^\circ\text{F}/\text{min}$ ]~~)]~~.

11.3.1.1 If DTA equipment is used, refer to Test Method D 3418 except that the DTA shall be run at  $10^\circ\text{C}/\text{min}$  to  $325^\circ\text{C}$ -~~(~~[ $617^\circ\text{F}$ ]~~)]~~.

11.3.1.2 With either the DTA or DSC, extend the straight lines tangent to both sides of the endotherm melting temperature. Take the temperature at which the lines intersect as the endotherm melting peak temperature.

11.3.2 *Precision*—The single instrument precision of the differential thermal analysis applied to this test method is  $\pm 1.2^\circ\text{C}$  (2S) as defined in Practice E 177.

~~11.3.3 Other thermal techniques capable of measuring the melting endotherm giving equivalent results may be used.~~

11.4 *Tensile Properties*:

11.4.1 Cut five specimens with the microtensile die shown in Fig. 1. The die shall be of the steel-rule or solid metal type of curvature of  $5 \pm 0.5\text{-mm}$ -~~(~~[ $0.2 \pm 0.02\text{-in.}$ ]~~)]~~ type. Determine the tensile properties in accordance with the procedures described in Test Method D 638 except that the specimens used shall be as detailed above, the initial jaw separation shall be  $22.0 \pm 0.13\text{ mm}$  ~~(~~[ $0.875 \pm 0.005\text{ in.}$ ]~~)]~~, and the speed of testing shall be  $50 \pm 5\text{ mm}/\text{min}$ -~~(~~[ $2 \pm 0.2\text{ in.}/\text{min}$ ]~~)]~~. Clamp the specimens with essentially equal lengths in each jaw. Determine the elongation from the chart, expressing it as a percentage of the initial jaw separation.

11.4.2 *Precision*—For tensile strength, the within-laboratory precision is  $\pm 5\%$  of the average (2S), and the between-laboratory precision is  $\pm 7\%$  of the average (2S). For elongation, the within-laboratory precision is  $\pm 10\%$  (2S), and the between-laboratory precision is  $12\%$  (2S).<sup>7</sup>

11.4.3 *Bias*—No statement of bias can be prepared for this test method, since there is no absolute method for use as a comparison basis.

11.5 *Dielectric Constant and Dissipation Factor*—Determine dielectric constant and dissipation factor in accordance with Test Methods D 150. Testing shall be done at  $10^3\text{ Hz}$  and  $10^6\text{ Hz}$ .

## 12. Number of Tests

12.1 One set of test specimens as prescribed in Section 11 shall be considered sufficient for testing each sample. The average result of the samples tested shall conform to the requirements of this specification.

## 13. Certification and Inspection

13.1 Inspection and certification of the material supplied with reference to this specification shall be for conformance to the requirements specified herein.

13.2 Lot-acceptance inspection shall be the basis on which acceptance or rejection of the lot is made. The lot-acceptance inspection shall consist of the following:

13.2.1 Melt flow rate, and

13.2.2 Melting point.

13.3 Periodic-check inspection with reference to a specification shall consist of the tests for all requirements of the material under the specification. Inspection frequency shall be adequate to ensure the material is certifiable in accordance with 13.4.

13.4 Certification shall be that the material was manufactured by a process in statistical control, sampled, tested and that the average values for the lot meet the requirements of the specification.

13.5 *Reports*—When specified in the purchase order or contract, a report of the test results shall be furnished. The report shall consist of results of the lot-acceptance inspection for the shipment.

## 14. Keywords

14.1 ETFE fluoropolymer; extrusion material; fluoropolymers; melt-processible fluoropolymer; molding material; recycled;

<sup>7</sup>See the ASTM Form and Style Manual.

<sup>7</sup>Supporting data are available from ASTM Headquarters, Request RR:D20-1067.

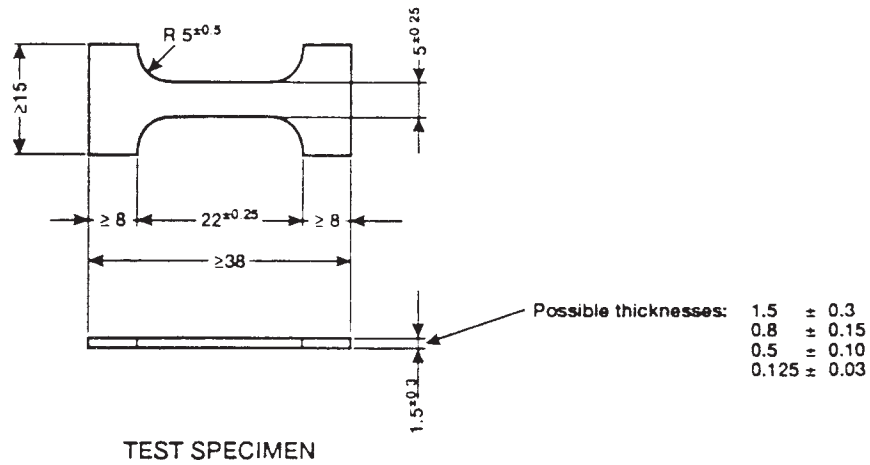
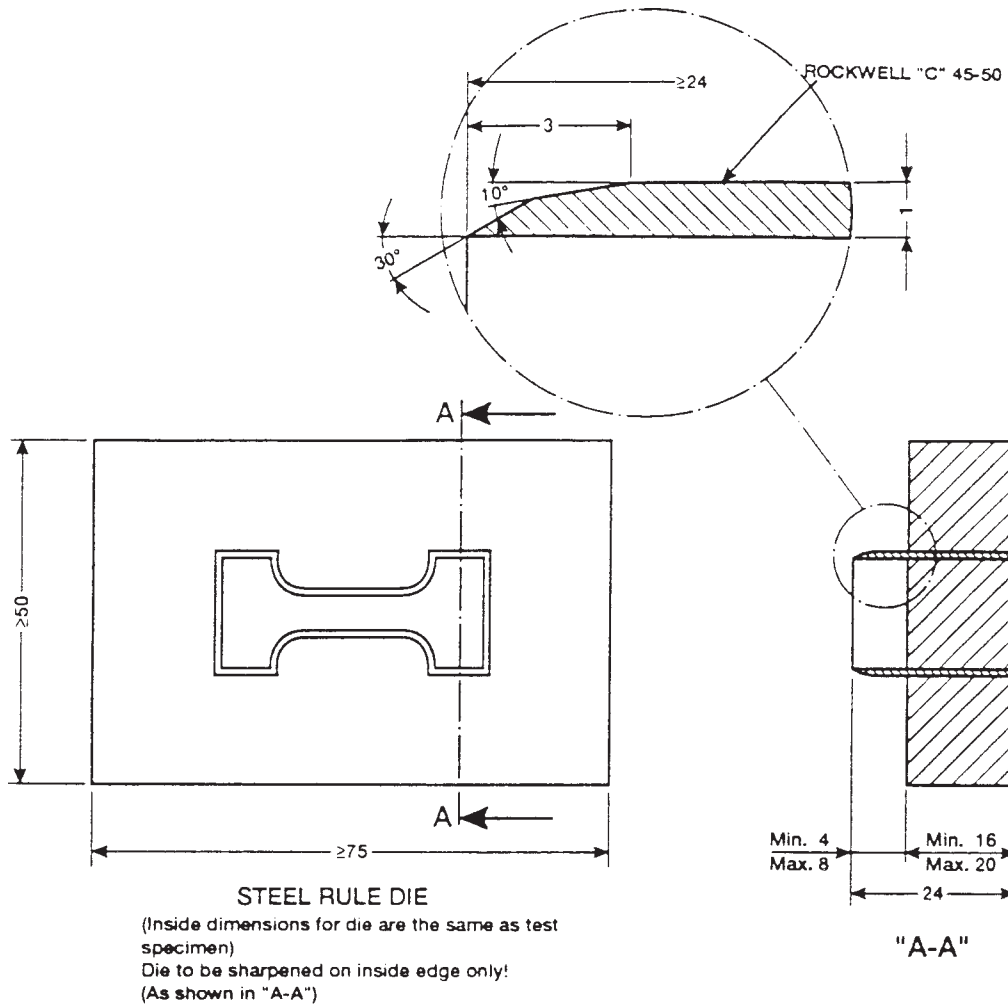

NOTE—All dimensions are in millimetres.

FIG. 1 Microtensile Die

tetrafluoroethylene copolymers; tetrafluoroethylene-ethylene copolymers

**SUMMARY OF CHANGES**

This section identifies the location of selected changes to this specification. For the convenience of the user, Committee D-20 has highlighted those changes that may impact the use of this specification. This section may also include descriptions of the changes, or reasons for the changes, or both.

**D 3159–04:**

- (1) Changed the terms “may” and “should” to “shall” throughout the standard.
- (2) Deleted 11.3.3 to conform to other fluoropolymer specifications.
- (3) Added new grades, Type I Grade 3 and Type IV Grade 1, to Tables 1 and 2.

**D 3159–98:**

- (1) Added IEEE/ASTM SI 10 in 1.2.
- (2) Added statement for recycled products in 1.4.
- (3) Deleted reference to Practice D 1898.
- (4) Added IEEE/ASTM SI-10 in 2.1.
- (5) Added *lot* definition in 3.1.2.
- (6) Replaced Practice D 1898 with an adequate statistical sampling program in 7.1 to be consistent with Guide D 5740.
- (7) In Section 13, replaced with wording from Guide D 5740 for clarity.

*ASTM International takes no position respecting the validity of any patent rights asserted in connection with any item mentioned in this standard. Users of this standard are expressly advised that determination of the validity of any such patent rights, and the risk of infringement of such rights, are entirely their own responsibility.*

*This standard is subject to revision at any time by the responsible technical committee and must be reviewed every five years and if not revised, either reapproved or withdrawn. Your comments are invited either for revision of this standard or for additional standards and should be addressed to ASTM International Headquarters. Your comments will receive careful consideration at a meeting of the responsible technical committee, which you may attend. If you feel that your comments have not received a fair hearing you should make your views known to the ASTM Committee on Standards, at the address shown below.*

*This standard is copyrighted by ASTM International, 100 Barr Harbor Drive, PO Box C700, West Conshohocken, PA 19428-2959, United States. Individual reprints (single or multiple copies) of this standard may be obtained by contacting ASTM at the above address or at 610-832-9585 (phone), 610-832-9555 (fax), or [service@astm.org](mailto:service@astm.org) (e-mail); or through the ASTM website ([www.astm.org](http://www.astm.org)).*