



Designation: ~~D 746—98~~^{€1} 746 – 04

Standard Test Method for Brittleness Temperature of Plastics and Elastomers by Impact¹

This standard is issued under the fixed designation D 746; the number immediately following the designation indicates the year of original adoption or, in the case of revision, the year of last revision. A number in parentheses indicates the year of last reapproval. A superscript epsilon (€) indicates an editorial change since the last revision or reapproval.

^{€1} NOTE—Editorially corrected 8.1.2 and 8.2.2 in April 2002.

1. Scope*

1.1 This test method covers the determination of the temperature at which plastics and elastomers exhibit brittle failure under specified impact conditions. Two routine inspection and acceptance procedures are also provided.

NOTE 1—When testing rubbers for impact brittleness use Test Methods D 2137.

1.2 The values stated in SI units are to be regarded as the standard.

1.3 *This standard does not purport to address all of the safety concerns, if any, associated with its use. It is the responsibility of the user of this standard to establish appropriate safety and health practices and determine the applicability of regulatory limitations prior to use.*

NOTE 2—This test method and ~~ISO 974-1980~~ ISO 974-2000 (E) are technically equivalent when using the Type B fixture and the Type III specimen, however, the minimum number of specimens that are required to be tested ~~may be~~ is significantly different when using this test method. The ISO method requires that a minimum of 100 specimens be tested.

¹ This test method is under the jurisdiction of ASTM Committee D-20 on Plastics and is the direct responsibility of Subcommittee D20.30 on Thermal Properties (Section D20.30.07).

Current edition approved July 10, 1998; May 1, 2004. Published January 1999; May 2004. Originally published as D 746—43 T; approved in 1943. Last previous edition approved in 1998 as D 746 — 958.

*A Summary of Changes section appears at the end of this standard.

2. Referenced Documents

2.1 *ASTM Standards:*²

- D 618 Practice for Conditioning Plastics and Electrical Insulating Materials for Testing
- D 832 Practice for Rubber Conditioning for Low-Temperature Testing
- D 883 Terminology Relating to Plastics
- ~~D 1898 Practice for Sampling of Plastics²~~
- ~~D 2137 Test 2137 Test Methods for Rubber Property—Brittleness Point of Flexible Polymers and Coated Fabrics~~
- E 77 Test Method for the Inspection and Verification of Thermometers
- E 220 Test Method for Calibration of Thermocouples by Comparison Techniques
- E 644 Test Methods for Testing Industrial Resistance Thermometers
- E 1137 Specification for Industrial Platinum Resistance Thermometers

2.2 *ISO Standard:*

- ISO 974-1980 (E) Plastics—Determination of the Brittleness Temperature by Impact³

3. Terminology

3.1 *General*—The definitions of plastics used in this test method are in accordance with Test Method D 883 unless otherwise specified.

3.2 *brittleness temperature*—that temperature, estimated statistically, at which 50 % of the specimens would probably fail.

4. Summary of Test Method

4.1 To determine the brittleness temperature, specimens are secured to a specimen holder with a torque wrench. The specimen holder is immersed in a bath containing a heat-transfer medium that is cooled. The specimens are struck at a specified linear speed and then examined. The brittleness temperature is defined as the temperature at which 50 % of the specimens fail.

5. Significance and Use

5.1 This test method establishes the temperature at which 50 % of the specimens tested fail when subjected to the conditions specified herein. The test provides for the evaluation of long-time effects such as crystallization, or those effects that may be ~~are~~ introduced by low-temperature incompatibility of plasticizers in the material under test. Plastics and elastomers are used in many applications requiring low-temperature flexing with or without impact. ~~Use data obtained by this test method may be used to predict the behavior of plastic and elastomeric materials at low temperatures only in applications in which the conditions of deformation are similar to those specified in this test method. This test method has been found useful for specification purposes, but does not necessarily measure the lowest temperature at which the material may be used; is suitable for use.~~

NOTE 3—Suitable apparatus is commercially available from several suppliers. The striking member may be motor-driven, solenoid-operated, gravity-actuated, or spring-loaded. ~~The Equip the motor-driven tester should be equipped~~ with a safety interlock to prevent striker arm motion when the cover is open.

6. Apparatus

6.1 *Type A:*

² For referenced ASTM standards, visit the ASTM website, www.astm.org, or contact ASTM Customer Service at service@astm.org. For *Annual Book of ASTM Standards*, Vol 08.04, volume information, refer to the standard's Document Summary page on the ASTM website.

³ *Annual Book of ASTM Standards, ISO Standards Handbook 21*, Vol 09.04, 1. ISO Standards are available from American National Standards Institute (ANSI), 25 W. 43rd St., 4th Floor, New York, NY 10036.

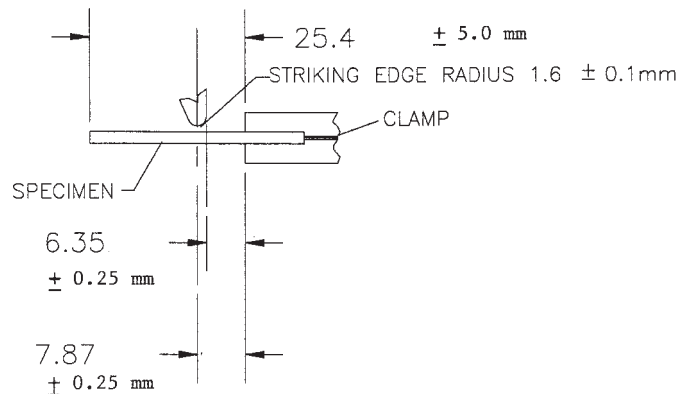
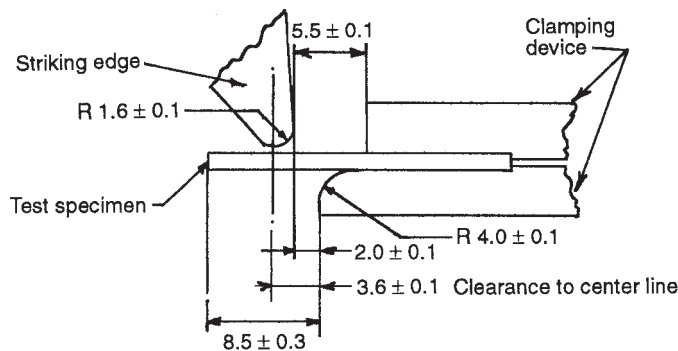

FIG. 1 Dimensional Requirements Between Specimen Clamp and Striking Edge (Type A)



FIG. 2 Typical Clamp (Type A)



NOTE—Dimensions are in millimetres.

FIG. 3 Dimensional Details of Striking Edge and Clamping Device, Type B (Positioning of Unnotched Test Specimen)

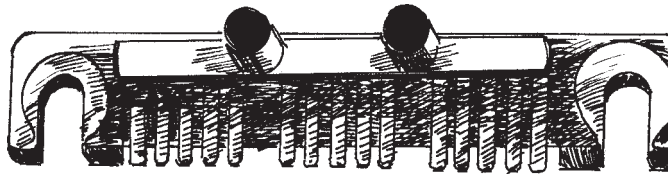

FIG. 4 Assembled Clamp with Test Specimens, Type B

6.1.1 *Specimen Clamp and Striking Member*—Design the specimen clamp to hold the specimen or specimens as a cantilever beam. Each individual specimen shall be firmly and securely held in a separate clamp. The striking edge shall move relative to the specimens at a linear speed of 2000 ± 200 mm/s at impact and during at least the following 6.4 mm of travel. In order to maintain this speed on some instruments, it may be is necessary to reduce the number of specimens tested at one time. The distance between the center line of the striking edge and the clamp shall be 7.87 ± 0.25 mm at impact. The striking edge shall have a radius of 1.6 ± 0.1 mm. The striking arm and specimen clamp shall have a clearance of 6.35 ± 0.25 mm at and immediately following impact. These dimensional requirements are illustrated in Fig. 1. Fig. 2 shows a typical clamp.⁴ Use free-fitting clamping screws, 10-32 National Fine Thread.

Annual Book

⁴ A detailed drawing of a typical clamp may be obtained from ASTM Standards, Vol 14.03: Headquarters. Order Adjunct : ADJD0746.

6.2 Type B:

6.2.1 *Specimen Clamp and Striking Member*—Design the specimen clamp to hold the specimen or specimens as a cantilever beam. Each individual specimen shall be firmly and securely held in a separate clamp. The striking edge shall move relative to the specimens at a linear speed of 2000 ± 200 mm/s at impact and during at least the following 5.0 mm of travel. In order to maintain this speed on some instruments, it may be necessary to reduce the number of specimens tested at one time. The radius of the lower jaw of the clamp shall be 4.0 ± 0.1 mm. The striking edge shall have a radius of 1.6 ± 0.1 mm. The striking edge and specimen clamp shall have a clearance of 3.6 ± 0.1 mm at and immediately following impact. The clearance between the outside of the striking edge and the clamp shall be 2.0 ± 0.1 mm at impact. These dimensional requirements of the striking edge and clamping device are illustrated in Fig. 3. Fig. 4 shows a typical clamp. Details of the specimen clamp are given in Fig. 5.

6.3 *Torque Wrench*, 0 to 8.5 N · m.

NOTE 4—Because of the difference in geometry of the specimen clamps, test results obtained when using the Type A specimen clamp and striking member may not correlate with those results obtained when using the Type B apparatus.

6.4 *Temperature-Measurement System*—The temperature of the heat-transfer medium shall be determined with a thermocouple or resistance thermometer having a suitable range for the temperatures at which the determinations are to be made. The temperature-measuring device and the related readout equipment shall be accurate to at least $\pm 0.5^\circ\text{C}$. The temperature-measuring device shall be located as close to the specimens as possible. Thermocouples shall be calibrated in accordance with Test Method E 220. Resistance temperature devices shall comply with the requirements of Test Methods E 644 and Specification E 1137.

NOTE 5—A thermometer may be permitted to be used if it can be shown to agree with the specified temperature measuring system. Mercury-in-glass thermometers shall be calibrated for the depth of immersion in accordance with Test Method E 77.

6.5 *Heat-Transfer Medium*—A Use any liquid heat transfer medium that remains fluid at the test temperature and will does not appreciably affect the material tested may be used, being tested. Measurement of selected physical properties prior to and after

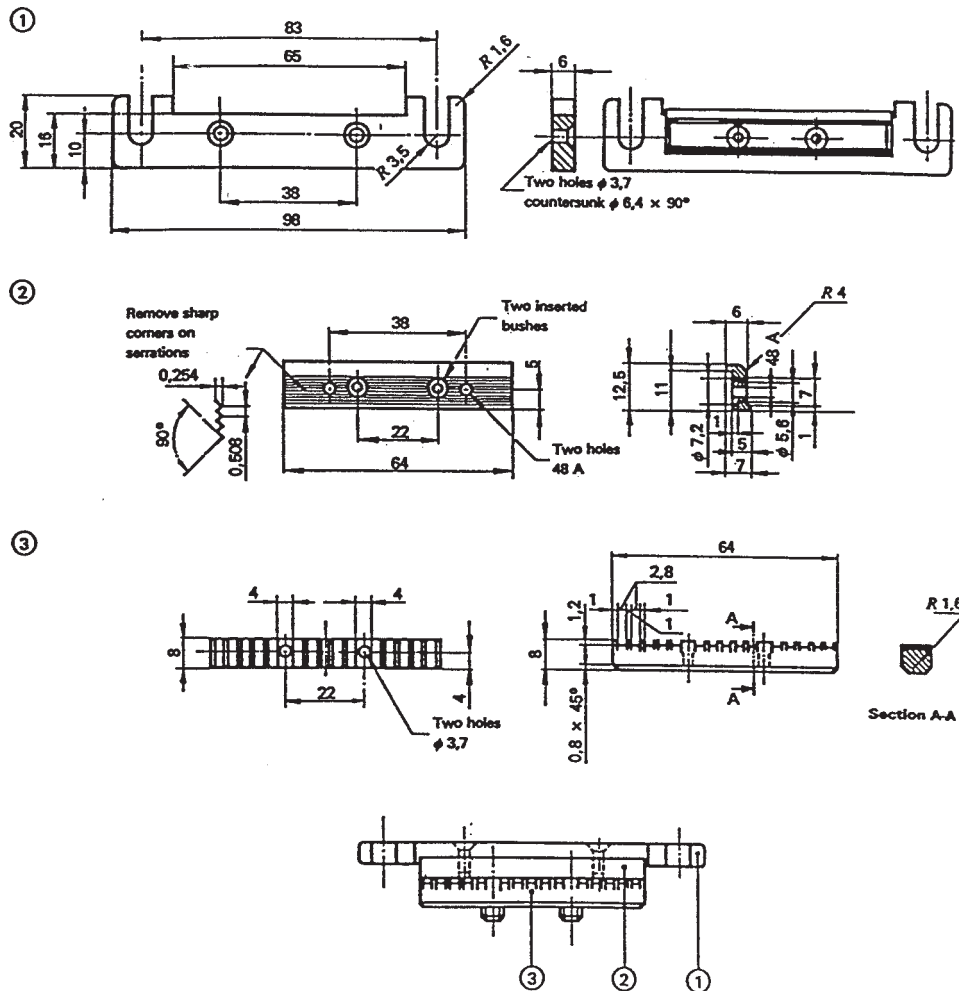

NOTE—Dimensions are in millimetres.

FIG. 5 Details of One Form of Clamp Meeting the Requirements of 6.2

15-min exposure at the highest temperature used will provide an indication of the inertness of a plastic to the heat transfer ~~medium~~. ~~There should be no significant difference between the results.~~ medium.

6.5.1 Where a flammable or toxic solvent is used as the cooling medium, ~~the follow~~ customary precautions ~~in~~ when handling such a ~~material should be exercised.~~ materials. Methanol is the recommended heat transfer medium for rubber.

NOTE 6—The following materials have been found suitable for use at the indicated temperatures. When silicone oil is used, moisture from the air will condense on the surface of the oil, causing slush to form. ~~This If slush may collect collects~~ on the temperature-measuring device as ~~ice and ice~~, it will affect temperature measurement. ~~If When this should occur, occurs,~~ remove the ice from the temperature-measuring device.

Material	Temperature, °C
5-mm ² /s viscosity silicone oil	-60
2-mm ² /s viscosity silicone oil	-76
Methyl alcohol	-90

6.6 *Temperature Control*—Suitable means (automatic or manual) shall be provided for controlling the temperature of the heat-transfer medium to within $\pm 0.5^\circ\text{C}$ of the desired value. Powdered solid carbon dioxide (dry ice) and liquid nitrogen are recommended for lowering the temperature, and an electric immersion heater for raising the temperature.

6.7 *Tank*, insulated.

6.8 *Stirrer*, to provide thorough circulation of the heat transfer medium.

7. Sampling

7.1 Unless otherwise agreed upon between the seller and the purchaser, sampling shall be in accordance with the General and Specific Sampling Procedures sections of Practice D 1898. Sampling, based on engineering principles, prior to packaging shall be considered an acceptable alternative.

8. Test Specimen

8.1 *Type I (for Fixture Type A)* :

8.1.1 *Geometry*—This type of specimen shall be 6.35 ± 0.51 mm wide by 31.75 ± 6.35 mm long as illustrated in Fig. 6.

8.1.2 *Preparation*—~~Cut the test specimens from a flat sheet with a thickness of 1.91 ± 0.13 mm. The specimens may~~ Specimens shall be 1.91 ± 0.13 mm thick. Specimens shall be die-punched, cut by hand using a razor blade or other sharp tool, or cut by an automatic machine. Specimens may also be machine from flat sheet, or prepared by injection molding.

8.2 *Type II (for Fixture Type A)* :

8.2.1 *Geometry (Modified T-50 Specimen)*—This type of specimen shall be T-shaped, as illustrated in Fig. 6. When using this type of specimen, clamp it so that the entire tab is inside the jaws for a minimum distance of 3.18 mm.

8.2.2 *Preparation*—~~Cut the test specimens from a flat sheet with a thickness of 1.91 ± 0.13 mm. The specimens may~~ Specimens shall be 1.91 ± 0.13 mm thick. Specimens shall be die-punched, cut by hand using a razor blade or other sharp tool, or cut by an automatic machine. Specimens may also be machine from flat sheet, or prepared by injection molding.

8.3 *Type III (for Fixture Type B)*:

8.3.1 *Geometry*—This type of specimen shall be 20.0 ± 0.25 mm long by 2.5 ± 0.05 mm wide and 1.6 ± 0.1 mm thick as illustrated in Fig. 6.

8.3.2 *Preparation*—~~Cut the test specimens from a flat sheet. The specimens may~~ Specimens shall be die-punched, cut by hand using a razor blade or other sharp tool, or cut by an automatic machine. Specimens may also be machine from flat sheet, or prepared by injection molding.

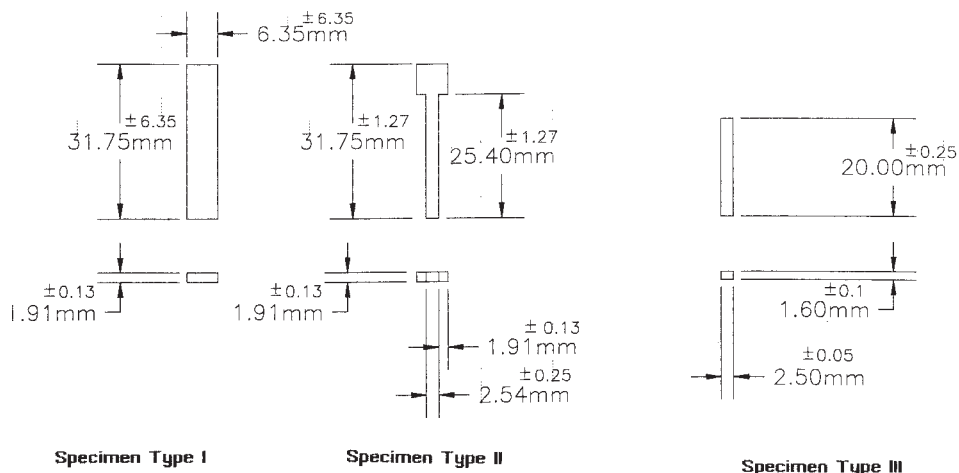

FIG. 6 Specimen Geometry

87.4 Test results will vary according to molding conditions and methods of specimen preparation. It is essential that preparation methods produce uniform specimens. The preferred method of preparation is to use an automatic cutting machine. ~~Alternatively, machine, however specimens may be die-punched~~ that are punched using an arbor press or hydraulically operated press are also acceptable. No matter which preparation method is employed, the specimen edges shall be free of all flash. Specimens that are damaged in any way shall be discarded. If specimens are to be die punched, sharp dies must be used in the preparation of specimens for this test if reliable results are to be achieved. Careful maintenance of die cutting edges is of extreme importance and ~~can be~~ is obtained by daily lightly honing and touching up the cutting edges with jewelers' hard Arkansas honing stones. The condition of the die ~~may be~~ is judged by investigating the rupture point on any series of broken specimens. When broken specimens are removed from the clamps of the testing machine it is advantageous to pile these specimens and note if there is any tendency to break at or near the same portion of each specimen. Rupture points consistently at the same place ~~may be~~ are the indication that the die is dull, nicked, or bent at that particular position, or that some other defect is present.

98. Conditioning

98.1 *Conditioning*— Condition the test specimens at $23 \pm 2^\circ\text{C}$ and $50 \pm 5\%$ relative humidity for not less than 40 h prior to the test in accordance with Procedure A of Practice D 618 for those tests where conditioning is required. In cases of disagreement, the tolerances shall be $\pm 1^\circ\text{C}$ and $\pm 2\%$ relative humidity. ~~NOTE 7—Where~~

8.2 ~~Where~~ long-time effects such as crystallization, incompatibility, etc., and so forth, of materials are to be studied, condition the test specimens ~~may be conditioned~~ in accordance with Practice D 832.

~~10.—~~

9. Procedure

109.1 In establishing the brittleness temperature of a material, it is recommended that the test be started at a temperature at which 50 % failure is expected. Test a minimum of ten specimens at this temperature. If all of the specimens fail, increase the temperature of the bath by 10°C and repeat the test using new specimens. If none of the specimens fail, decrease the bath temperature by 10°C and repeat the test using new specimens. If the approximate brittleness temperature is not known, select the start temperature ~~should be chosen~~ arbitrarily.

109.2 Prior to beginning a test, prepare the bath and bring the apparatus to the desired starting temperature. If the bath is cooled using dry ice, place a suitable amount of powdered dry ice in the insulated tank and slowly add the heat-transfer medium until the tank is filled to a level 30 to 50 mm from the top. If the apparatus is equipped with a liquid nitrogen or CO_2 cooling system and automatic temperature control, follow instructions provided by the manufacturer of the instrument for preparing and operating the bath.

109.3 Mount the test specimens firmly in the clamping device. Secure the specimens with a torque wrench. To avoid excessive deformation of the specimens, use a torque suitable for the material being tested.

NOTE 87—It is recommended that a clamping torque of $0.56 \pm 0.01 \text{ N} \cdot \text{m}$ ($5 \pm 0.1 \text{ lb} \cdot \text{in.}$) be used to mount the samples. If slippage of the specimens in the clamp occurs, increase the torque the minimum amount necessary to eliminate the slippage.

109.4 Mount the clamping device in the testing apparatus and lower the clamping device into the heat-transfer medium. If dry ice is being used as a coolant, maintain constant temperature by the judicious addition of small quantities of dry ice. If the apparatus is equipped with a liquid nitrogen or CO_2 cooling system and automatic temperature control, follow the manufacturer's instructions for setting and maintaining temperature.

109.5 After waiting for 3 ± 0.5 min, record the temperature and deliver a single impact to the specimens.

109.6 Remove the clamping device from the testing apparatus and remove the individual specimens from the clamping device. Allow the specimens to warm up prior to being bent for inspection of ~~cracks. This may be done~~ cracks by leaving the specimens at room temperature for 1 min or by placing them in lukewarm water for 10 to 15 s. Examine each specimen to determine whether or not it has failed. Failure is defined as the division of a specimen into two or more completely separated pieces or as any crack in the specimen which is visible to the unaided eye. Where a specimen has not completely separated, it shall be bent to an angle of 90° in the same direction as the bend caused by the impact. It should then be impact and examined for cracks at the bend. Record the number of failures and the temperature at which they were tested.

109.7 Increase or decrease the temperature of the bath in uniform increments of 2 or 5°C and repeat the procedure until the lowest temperature at which none of the specimens fail and the highest temperature at which all of the specimens fail is determined. A minimum of four tests shall be conducted in that temperature range. ~~Ten new~~ New specimens ~~should~~ are to be used for each test.

110. Routine Inspection and Acceptance

110.1 *Procedure A*— For routine inspection of materials received from an approved supplier, it shall be satisfactory to accept lots on the basis of testing a minimum of ten specimens at a specified temperature as stated in the relevant material specifications. Not more than five shall fail (see Section ~~10~~).

~~11.2~~ 9.

10.2 Procedure B— It shall be satisfactory to accept elastomeric composition on a basis of testing five specimens at a specified temperature, as stated in the relevant material specifications. None shall fail.

121. Calculation

121.1 Standard Method— Using the number of specimens that failed, calculate the percentage of failures at each temperature. Calculate the brittleness temperature of the material as follows:

$$T_b = T_h + \Delta T[(S/100) - (1/2)]$$

where:

T_b = brittleness temperature, °C,

T_h = highest temperature at which failure of all the specimens occurs (proper algebraic sign must be used), °C,

ΔT = temperature increment, °C, and

S = sum of the percentage of breaks at each temperature (from a temperature corresponding to no breaks down to and including T_h). Derivations of the above formula are contained in other references.^{7,8}

~~NOTE 9~~ **8—Example:** The following example illustrates application of this formula:

Material—Plasticized poly(vinyl chloride)

Number of Specimens Tested at Each Temperature—Ten.

At -30°C, 0 failed

At -32°C, 2 failed

At -34°C, 3 failed

At -36°C, 6 failed

At -38°C, 8 failed

At -40°C, 10 failed

At -42°C, 10 failed

Then: T_h = -40°C

ΔT = 2

S = 20 + 20 + 30 + 60 + 80 + 100 = 290

Since: T_b = $T_h + \Delta T [(S/100) - (1/2)]$

Then: T_b = -40 + 4.8 = -35.2°C

Brittleness temperature, reported as -35°C.

121.2 Alternative Graphic Method—The value reported by this graphic method is essentially the same as that calculated by the standard method described in 121.1, but may be is obtained without determining either the highest temperature at which all specimens fail or the lowest at which all pass the test. When testing materials that possess a wide temperature range of brittleness transition, the graphic method also requires the testing of fewer sets of samples to determine the brittleness temperature. Select sets of ten specimens each in which both failures and nonfailures occur at four or more temperatures. Choose temperatures above and below the estimated 50 % failure point. Plot the data on probability graph paper with temperature on the linear scale and percent failure on the probability scale. Select the temperature scale so that it represents a minimum of two divisions for each degree. Draw the best fitting straight line through these points. The temperature indicated at the intersection of the data line with the 50 % probability line shall be reported as the brittleness temperature, T_b . Where there is a question of conformance to the relevant material specification, the value obtained according to 121.1 shall be accepted as the T_b value.

~~NOTE 10~~ **The 9**—The graphic method applied to the data from the example in Note 9 8 is shown in Fig. 7. The brittleness temperature, T_b , estimated to the nearest degree is -35°C.

132. Report

132.1 Report the following information:

132.1.1 Reference to this test method,

132.1.2 Complete identification of the material tested, including type, source, manufacturer's code designation, form in which supplied, and previous history,

132.1.3 Specimen type, dimensions, and method of preparation,

132.1.4 Specimen conditioning methods, if any, including time elapsed since molding or annealing,

132.1.5 Torque used to secure the specimens,

132.1.6 Brittleness temperature to the nearest 1°C,

132.1.7 Type of test apparatus and heat-transfer medium used,

132.1.8 Method of calculation, and

132.1.9 Date of test.

132.2 For routine inspection and acceptance testing only, the following shall be recorded instead of 132.1.6 and 132.1.8:

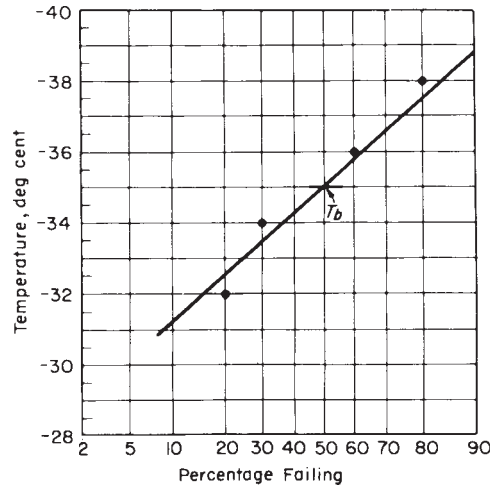

FIG. 7 Graphic Method for Determining the T_b Brittleness Temperature

- 132.2.1 Number of specimens tested,
- 132.2.2 Temperature of test, and
- 132.2.3 Number of failures.

143. Precision and Bias

143.1 *Precision*— Table 1 is based on a round-robin test conducted in 1997 involving three materials and nine laboratories. Each laboratory made two determinations on each material. This study has been submitted to ASTM to be filed as a research report.

143.1.1 S_r is the within-laboratory standard deviation of the average; $r = 2.8 S_r$. (See 143.1.3 for application of r .)

143.1.2 S_R is the between-laboratory standard deviation of the average; $R = 2.8 S_R$. (See 143.1.4 for application of R .)

143.1.3 *Repeatability*— In comparing two test results for the same material, obtained by the same operator using the same equipment on the same day, those test results should be judged not equivalent if they differ by more than the r value for the material and condition.

143.1.4 *Reproducibility*— In comparing two test results for the same material, obtained by different operators using different equipment on different days, those test results should be judged not equivalent if they differ by more than the R value for the material and condition. (This applies between different laboratories or between different equipment within the same laboratory.)

143.1.5 Any judgement in accordance with 143.1.3 and 143.1.4 will have an approximate 95 % (0.95) probability of being correct.

143.2 *Bias*—There are no recognized standards on which to base an estimate of bias for this test method.

154. Keywords

- 154.1 brittle failure; brittleness temperature; elastomer; impact plastics

APPENDIXES

(Nonmandatory Information)

X1. STRIKER MECHANISM VELOCITY CALIBRATION FOR THE SOLENOID-ACTUATED BRITTLENESS TESTER

X1.1 Calibration is accomplished by measuring the height, h , to which a steel ball, suspended on the striker mechanism of the tester, rises after the striker has had its upward motion halted by contact with a mechanical stop. The ball is accelerated in such a manner that the law governing a freely falling body applies. The velocity, v , of the striker is readily calculated from the following expression:

TABLE 1 Precision and Bias Data

Materials	Average	S_r	S_R	r	R
#1 Injection Molded PP	-8.5	0.67	1.90	1.89	5.33
#2 Injection Molded PP	-31.9	1.11	4.33	3.11	12.12
#3 Die Cut PE	-35.1	2.22	9.03	6.22	25.28

$$v = \sqrt{2gh}$$

X1.2 *Securing Ball Support*—Remove either one of the nuts that fasten the striking bar guide rods to the solenoid armature yoke. Place the small hole of the ball support (Fig. X1.1) over the guide rod and replace and secure the nut.

X1.3 *Adjusting Stroke of Striker*—Remove the metal guard from around the solenoid. Spread open the rubber bumper (Fig. X1.2) and insert it around the armature. Replace the solenoid guard. Insert a typical rubber or plastic specimen into the specimen holder of the tester. Raise the striking mechanism by hand until the end of the stroke is reached. It is essential that, with the striking mechanism raised to its maximum height, the striker bar of the tester be in contact with the specimen but that the bar not be in the plane of the specimen. If the striker bar is not in contact with the specimen, the rubber bumper must be removed and replaced by a thinner bumper. Conversely, if the striker bar moves into the plane of the specimen, the bumper must be replaced by a thicker one.

X1.4 *Placement of Ball and Measuring Tube*—Place a 19-mm diameter steel ball on the ball holder. (In theory, the upward flight of the ball is independent of the mass of the ball. However, if the mass is too large, the motion of the striker bar ~~may~~ will be impeded.) Clamp a glass or clear plastic tube with a minimum inside diameter of 25.4 mm in a vertical position directly over the ball. The tube ~~should contain~~ contains a scale divided into 5-mm intervals. ~~The~~ Align the zero position on the scale ~~should be aligned~~ with the top of the ball when the ball is at the top of the stroke of the striker mechanism.

X1.5 *Measurement and Calculation*—With the tester equipped as described above and devoid of test specimens and immersion medium, fire the solenoid and read the ball height to the closest 5 mm. Make at least five measurements. Average all results and convert the average to metres. Determine the striker velocity, v , from the following equation:

$$v = \sqrt{2gh}$$

where:

- v = velocity, m/s,
- g = 9.8 m/s², and
- h = average ball height, m.

NOTE X1.1—Calibration measurements ~~should~~ are to be made with the tester supported on a nonresilient surface, such as a laboratory bench or concrete floor. Resilient mountings tend to absorb some of the striker energy causing low ball height values.

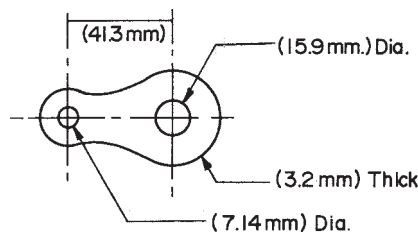

FIG. X1.1 Ball Support

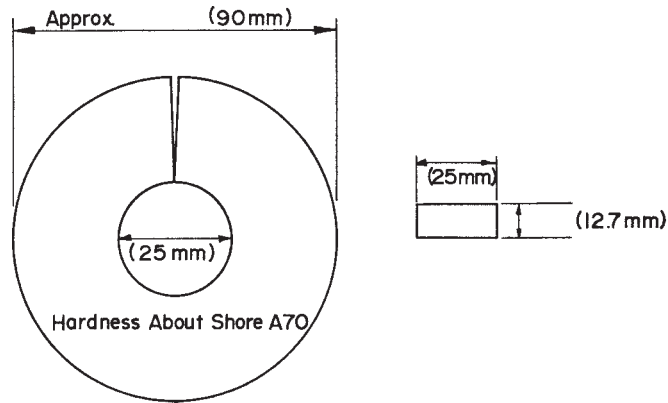

FIG. X1.2 Rubber Bumper

X2. STRIKER MECHANISM VELOCITY CALIBRATION FOR THE SOLENOID-ACTUATED BRITTLINESS TESTER DURING ACTUAL TESTING

X2.1 With the tester equipped with ball support, ball, and measuring tube (see Appendix X1), but without the rubber bumper (tester in normal operating condition) and devoid of test specimens and immersion medium, fire the solenoid and read the ball height to the closest 5 mm. Make ten measurements. From the lowest and highest ball height readings, determine the range in striker velocity, using the equation in X1.5. This range is termed “range of velocity at the top of the stroke.”

X2.2 With the tester equipped as described in X2.1, but also with test specimen(s) and immersion medium, conduct the brittleness test as outlined in Section 9. Read the ball height each time the solenoid is fired. Convert the ball height to velocity as shown in X1.5. If the velocity lies within the predetermined range of velocity at the top of the stroke, the test shall be considered valid. If the speed lies outside of the predetermined range, the test shall be invalid and ~~should~~ shall not be reported. ~~Should~~ If successive tests are found to be invalid, adjustments ~~should~~ shall be made to bring the velocity at the top of the stroke within the acceptable, predetermined range. This ~~may be~~ is accomplished by reducing the number of specimens tested per impact or by changing from Type A to Type B specimens.

X2.3 The following example typifies the entire velocity calibration procedure for solenoid-actuated testers:

X2.3.1 Using the procedure of Appendix X1, the striker velocity at point of impact of a tester devoid of test specimens and immersion medium was found to be 1.9 m/s. This velocity is within the specified limits of 5.1.1.

X2.3.2 Using the procedure of X2.1, with the tester devoid of test specimens and immersion medium, the range of striker velocity at the top of the stroke was found to be 2.5 to 2.7 m/s. This range becomes the acceptable range for this series of tests. The acceptable ranges ~~should~~ shall be established each time the striker velocity at point of impact is determined (see Appendix X1).

X2.3.3 Using the procedure of X2.2, with the tester containing a test specimen(s) and immersion medium, the velocity at the top of the stroke during the first solenoid firing was found to be 2.5 m/s. This velocity was within the acceptable range and the test was valid.

X2.3.4 The velocity at the top of the stroke during the second and third solenoid firings were found to be 2.4 and 2.3 m/s, respectively. These velocities are outside of the acceptable range and both tests are invalid.

X2.3.5 Adjustments were made to increase the velocity at the top of the stroke, using the procedures given in X2.2.

X2.3.6 The speeds at the top of the stroke during the fourth and all subsequent solenoid firings were found to lie between 2.5 and 2.7 m/s. The results of all these tests were valid.



SUMMARY OF CHANGES

Committee D-20 has identified

This section identifies the location of selected changes to this test method since method. For the last issue convenience of the user, Committee D20 has highlighted those changes that may impact the use of this test method. This section also includes descriptions of the changes or reasons for the changes, or both.

D 746 - 04:

- (1) Permissive language removed.
- (2) Section 7 on Sampling removed and subsequent sections renumbered.
- (3) D 1898 removed from Section 2.

D 746 – 98:

- (1) Section 14 13 was revised to include Precision and Bias statements as a result of an interlaboratory study.
- (2) Note 9 8 was revised to change the recommended clamping torque.
- (3) Paragraph 10.6 9.6 was revised to allow specimens to warm up before inspecting them for cracks.

ASTM International takes no position respecting the validity of any patent rights asserted in connection with any item mentioned in this standard. Users of this standard are expressly advised that determination of the validity of any such patent rights, and the risk of infringement of such rights, are entirely their own responsibility.

This standard is subject to revision at any time by the responsible technical committee and must be reviewed every five years and if not revised, either reapproved or withdrawn. Your comments are invited either for revision of this standard or for additional standards and should be addressed to ASTM International Headquarters. Your comments will receive careful consideration at a meeting of the responsible technical committee, which you may attend. If you feel that your comments have not received a fair hearing you should make your views known to the ASTM Committee on Standards, at the address shown below.

This standard is copyrighted by ASTM International, 100 Barr Harbor Drive, PO Box C700, West Conshohocken, PA 19428-2959, United States. Individual reprints (single or multiple copies) of this standard may be obtained by contacting ASTM at the above address or at 610-832-9585 (phone), 610-832-9555 (fax), or service@astm.org (e-mail); or through the ASTM website (www.astm.org).