



Designation: D 3575 – 00^{ε1}

Standard Test Methods for Flexible Cellular Materials Made From Olefin Polymers¹

This standard is issued under the fixed designation D 3575; the number immediately following the designation indicates the year of original adoption or, in the case of revision, the year of last revision. A number in parentheses indicates the year of last reapproval. A superscript epsilon (ϵ) indicates an editorial change since the last revision or reapproval.

^{ε1} NOTE—A note was added editorially to Section 30 in June 2001.

1. Scope

1.1 These test methods apply to flexible closed cell materials made from olefin polymers or blends of olefin polymers with other polymers as defined in Section 3.

1.2 This test method covers test procedures only. Product requirements are outlined in Specification D 4819.

1.3 Unless specifically stated otherwise, by agreement between the purchaser and supplier, all tests shall be performed in accordance with the test methods specified in this standard.

1.4 The values stated in SI units are to be regarded as the standard.

1.5 *This standard does not purport to address all of the safety concerns, if any, associated with its use. It is the responsibility of the user of this standard to establish appropriate safety and health practices and determine the applicability or regulatory limitations prior to use.*

2. Referenced Documents

2.1 *ASTM Standards:*

¹ These test methods are under the jurisdiction of ASTM Committee D20 on Plastics and are the direct responsibility of Subcommittee D20.22 on Cellular Plastics . Current edition approved Aug. 10, 2000. Published November 2000. Originally published as D 3575 – 77. Last previous edition D 3575 – 93.

- C 177 Test Method for Steady-State Heat Flux Measurements and Thermal Transmission Properties by Means of the Guarded-Hot-Plate Apparatus²
- C 518 Test Method for Steady-State Heat Flux Measurements and Thermal Transmission Properties by Means of the Heat Flow Meter Apparatus²
- D 412 Test Methods for Vulcanized Rubber and Thermoplastic Rubbers and Thermoplastic Elastomers—Tension³
- D 624 Test Method for Tear Strength of Conventional Vulcanized Rubber and Thermoplastic Elastomers³
- D 1056 Specification for Flexible Cellular Materials—Sponge or Expanded Rubber⁴
- D 1349 Practice for Rubber—Standard Temperatures for Testing³
- D 1596 Test Method for Absorbing Shock Cushioning Characteristics of Package Cushioning Materials⁵
- D 1667 Specification for Flexible Cellular Materials—Vinyl Chloride Polymers and Copolymers (Closed-Cell Foam)⁴
- D 2863 Test Method for Measuring the Minimum Oxygen Concentration to Support Candle-Like Combustion of Plastics (Oxygen Index)⁶
- D 4483 Practice for Determining Precision for Test Method Standards in the Rubber and Carbon Black Industries³
- D 4819 Specification for Flexible Cellular Materials Made from Polyolefin Plastics⁷
- F 355 Test Method for Shock-Absorbing Properties of Playing Surface Systems and Materials⁸

3. Terminology

3.1 Definitions of Terms Specific to This Standard:

- 3.1.1 *blend*—mixture of olefin polymers with other monomer(s) or polymer(s) in which at least 51 mass percent is the olefin polymer.
- 3.1.2 *cellular material, flexible*—a cellular organic polymeric material that will not rupture when a specimen 200 by 25 by 25 mm (8 by 1 by 1 in.) is bent around a 25-mm (1-in.) diameter mandrel at a uniform rate of one lap in 5 s at a temperature between 18 and 29°C.
- 3.1.3 *constant compression creep*—the time-dependent change in thickness of a material under a constant compressive stress or compression force.
- 3.1.4 *olefin polymers*—polymers made by the polymerization of olefins or copolymerization of olefins with other monomers, the olefins being at least 51 mass percent.

4. Summary of Test Methods

- 4.1 Table 1 contains a list of all the assigned suffix letters that may be used in describing the cellular products covered by these test methods.
- 4.2 These test methods do not contain test methods for all the suffix letters listed in Table 1. Where the test method is not included, it shall be arranged between the purchaser and supplier.
- 4.3 Test methods included in this standard are indicated in Table 1 by showing the applicable section numbers after the suffix letter.
- 4.4 In cases involving referee decisions, SI units shall be used.

5. Significance and Use

- 5.1 The test procedures provide a standard method of obtaining data for research and development, quality control, acceptance and rejection under specifications, and special purposes.
- 5.2 The data obtained by these test methods are applicable to the material under conditions of the particular test and are not necessarily the same as obtained in other environments or use conditions.

6. Sampling

- 6.1 When possible, use the completed manufactured product for the tests specified. Randomly select representative samples of the lot being examined, as required.
- 6.2 Extruded or molded shapes or sizes too small for cutting standard test specimens are difficult to classify or test by these test methods and will usually require special testing procedures or the use of standard test sheets.
- 6.3 When it is necessary or advisable to obtain test specimens from the article, as in those cases where the entire sample is not required or adaptable for testing, specify the method of cutting and the exact position from which specimens are to be taken. The apparent density and the state of crosslinking may vary in different parts of the finished product, especially if the article is of

² Annual Book of ASTM Standards, Vol 04.06.

³ Annual Book of ASTM Standards, Vol 09.01.

⁴ Annual Book of ASTM Standards, Vol 08.01.

⁵ Annual Book of ASTM Standards, Vol 15.09.

⁶ Annual Book of ASTM Standards, Vol 08.02.

⁷ Annual Book of ASTM Standards, Vol 08.03.

⁸ Annual Book of ASTM Standards, Vol 15.07.

TABLE 1 Suffix Letter Designations

NOTE 1—These suffix letters have been assigned by Subcommittee D11.33 and are consistent with those in Specifications D 1056 and D 1667.

Suffix Letter	Property	Section
A	Heat resistance	10-16
B	Compression set under constant deflection	
C	Ozone or weather resistance	
D	Compression deflection	17-23
E	Oil resistance	
F	Low temperature	
G	Tear resistance	24
H	Flex resistance	
I	Not assigned because of similarity to numeral 1	
J	Abrasion resistance	
K	Adhesion capability	
L	Water absorption	25-29
M	Flammability resistance	31
N	Impact resistance	
O	Electrical properties	
P	Staining resistance	
Q	Not assigned because of similarity to letter O	
R1	Resilience	
R2	Energy absorption	32
S	Thermal stability	33-39
T	Tensile strength and elongation	40
U	Not assigned	
V	Thermal conductivity	41 and 42
W	Density	43
X	Not assigned	
Y	Not assigned	
Z	Special requirements	
AA	Buoyancy	45-50
BB	Constant compressive creep	51-58
CC	Dynamic cushioning	59
DD	Open cell	
EE	Not assigned	
FF	Water vapor transmission	

complicated shape or of varying thickness, and these factors affect the physical properties of the specimens. Also, the apparent density is affected by the number of cut surfaces as opposed to the number of skin-covered surfaces on the test specimen.

6.4 When the finished product does not lend itself to testing or to the taking of test specimens because of complicated shape, small size, metal or fabric inserts, solid covers, adhesion to metal, or other reasons, prepare standard test sheets. When differences due to the difficulty in obtaining suitable test specimens from the finished part arise, the manufacturer and purchaser may agree on acceptable deviations. This can be done by comparing the results of standard test specimens and those obtained on actual parts.

6.5 If the material to be tested is anisotropic, prepare the test specimens so as to measure the property in the direction of interest in the application.

7. Conditioning

7.1 Conduct tests under known conditions of temperature and humidity or as specified in the individual test procedure. In case of dispute, conduct the test at a temperature of $23 \pm 2^\circ\text{C}$ ($73.4 \pm 3.6^\circ\text{F}$) and in an atmosphere of $50 \pm 5\%$ relative humidity. The product shall be conditioned, undeflected, and undistorted, at the temperature and humidity of test for at least 24 h before being tested.

7.2 It is recommended, for referee purposes, that all tests shall be performed 96 h or more after the foam has been manufactured.

8. Measurement of Test Specimens

8.1 Measure dimensions up to and including 25 mm (1 in.) using a dial-type gage with a minimum foot area of 650 mm^2 (1 in.^2). Pressure on the foot shall be held to $190 \pm 50\text{ Pa}$ ($0.028 \pm 0.007\text{ psi}$).

NOTE 1—Where foam is appreciably compressed by this test method, foot area and loading shall be as agreed upon between the purchaser and the supplier.

NOTE 2—Thickness of materials having irregular surface characteristics shall be measured as agreed upon between the purchaser and the supplier.

8.2 Dimensions over 25 mm (1 in.) may be measured with a dial gage, scale, or tape. Take care not to distort the test specimen.

8.3 The scale, tape, or gage shall be graduated to permit measurements within $\pm 1\%$ of the dimension to be measured.

8.4 Results reported shall be the average of a minimum of three equally spaced measurements of length and width and for thickness shall be the average of the center and four equally spaced measurements around the perimeter of the specimens.

9. Precision

9.1 The repeatability standard deviations for each test method has been determined. The reproducibility of these test methods is being determined and will be available on or before April 2005.

NOTE 3—The repeatability study was performed on two materials in two laboratories. For density (Method B), buoyancy, and compression creep, the material tested was a typical 64-kg/m³ density, crosslinked closed-cell olefin. For density (Method A), compression deflection, thermal stability, and water absorption, the material tested was a typical 32-kg/m³ density, crosslinked closed-cell olefin.

Suffix Tests

Suffix B—Compression Set Under Constant Deflection

10. Scope

10.1 This test method covers the deflection of the foam specimen under a compressive force and under specified conditions of time and temperature, then noting the effect on the thickness of the specimen after releasing the compressive force.

11. Apparatus

11.1 *Compression Device*, consisting of two or more flat plates arranged so the plates are held parallel to each other by bolts or clamps, and the space between the plates is adjustable to the required deflection thickness by means of spacers.

12. Test Specimens

12.1 The test specimens shall have parallel top and bottom surfaces and essentially perpendicular sides.

12.2 Specimens shall be 50 by 50 by 25 mm (2 by 2 by 1 in.) unless otherwise specified. Specimens less than 25 mm in thickness shall be plied up, without the use of an adhesive, to produce a total thickness of 25 mm.

NOTE 4—To obtain accurate data when testing foams with large cells or irregular surfaces, or both, larger samples approximately 100 by 100 by 25 mm (4 by 4 by 1 in.) are recommended.

13. Number of Specimens

13.1 Test three specimens for each sample. The values reported shall be the mean of those observed. If any value deviates more than 20 % from this mean, test two additional specimens and report the mean for all five values.

14. Procedure

14.1 Perform the entire test procedure at $23 \pm 2^\circ\text{C}$ ($73.4 \pm 3.6^\circ\text{F}$) and in an atmosphere of $50 \pm 5\%$ relative humidity.

NOTE 5—See Practice D 1349 if conditions other than these are desired.

14.2 Measure the test specimen original thickness (t_o) in accordance with the procedure in Section 8.

14.3 Place the test specimen in the apparatus and compressively deflect it to 50 % of its thickness.

14.4 Allow the test specimen to remain deflected in the apparatus for 22 h.

14.5 Remove the specimen from the test apparatus at the end of the 22-h period. Measure the final thickness (t_f) after 24 h of recovery.

15. Calculation

15.1 Calculate the constant deflection compression set, expressed as a percentage of the original thickness, as follows:

$$C_d = \frac{(t_o - t_f)}{t_o} \times 100 \quad (1)$$

where:

C_d = compression set expressed as a percent of the original thickness,

t_o = original thickness, mm (in.), and

t_f = thickness of the specimen after the specified recovery period, mm. (in.)

16. Report

16.1 Report the average compression set value, of the three specimens tested, for each sample, except as noted in 14.1.

17. Precision

17.1 The repeatability standard deviation has been determined to be 2.06. The reproducibility of this test method is being determined and will be available on or before April 2005. Values of data ranged from 14.36 to 21.37.

1	14.36
2	14.89
3	15.03
4	15.2
5	15.22
6	15.45
7	15.66
8	16.94
9	17.45
10	21.37

Average	16.157
Standard deviation	2.06

Suffix D—Compression Deflection (Also called Load Deflection or Compressive Strength)

18. Scope

18.1 This test method covers the measurement of the force necessary to produce a 25 % compression over the entire top area of the foam specimen.

NOTE 6—Compression deflection tests other than at 25 % may be specified as agreed upon between the purchaser and the supplier.

19. Apparatus

19.1 An apparatus shall be provided having a flat compression foot, larger than the specimen to be tested, connected to a force-measuring device and mounted in a manner such that the product or specimen can be deflected (compressed) at a speed of 0.2 to 4 mm/s (0.5 to 2 in./min). The apparatus shall be arranged to support the specimen on a level horizontal plate.

20. Test Specimens

20.1 The test specimen shall be a right cylinder with parallel top and bottom surfaces. The thickness shall be no greater than 75 % of the minimum top dimension.

20.2 Specimens shall be a minimum of 2500 mm² (4 in.²) in area and have a minimum thickness of 25 mm (1 in.). Specimens less than 25 mm thick shall be plied up, without the use of cement, to a minimum of 25 mm.

NOTE 7—Specimens less than 25 mm (1 in.) thick may be tested without being plied up, but the thickness must be specified.

21. Number of Specimens

21.1 Test three specimens for each sample. The values reported shall be the mean of those observed. If any value deviates more than 20 % from this mean, test two additional specimens and report the mean for all five values.

22. Procedure

22.1 Place the specimen centered in the line of the axial load on the supporting plate of the apparatus.

22.2 Bring the compression foot into contact with the specimen and determine the thickness after applying a total pretest-pressure of 190 ± 50 Pa (0.028 ± 0.007 psi) to the specimen area. Compress the specimen 25 ± 0.5 % of this thickness at 12.5 mm/min (0.5 in./min) and take the reading of the load immediately, unless another speed is specified.

NOTE 8—Where foam is appreciably compressed by this pretest-pressure, foot area and loading shall be as agreed upon between the purchaser and the supplier.

23. Calculation

23.1 Calculate the 25 % compression deflection force, per unit area of specimen, expressed as kilopascals (or pounds-force per square inch), as follows:

$$CD = \frac{F}{A} \tag{2}$$

where:

CD = compression deflection force per unit of specimen area, kPa (psi),

F = force required to compress the specimen 25 % of the thickness as measured in 8.2, N (lbf), and

A = specimen compression contact surface area, m² (in.²).

24. Report

24.1 Report the average thickness after pretest pressure and the average compression deflection, for the three specimens tested, in kilopascals (or pounds-force per square inch), required for 25 % compression, except as noted in 22.1.

25. Precision

25.1 The repeatability standard deviation has been determined to be 1.74. The reproducibility of this test method is being determined and will be available on or before April 2005. Values of data ranged from 34.61 to 40.61.

Compression Deflection, kPa

1	34.61
2	37.16
3	38.82
4	38.82
5	38.96
6	39.03
7	39.72
8	39.78
9	40.20
10	40.61
Average	38.77
Standard deviation	1.74

Suffix G—Tear Resistance, Test Method D 624

26. Test Method D 624

26.1 Die C shall be used.

26.2 Test the material at the thickness to be supplied, unless otherwise arranged by agreement between the purchaser and the supplier.

Suffix L—Water Absorption

27. Scope

27.1 This test method covers the measurement of the water absorbed by olefin polymer flexible cellular materials during submersion under pressure.

28. Test Specimens

28.1 Test specimens shall be 100 by 100 mm (4 by 4 in.) by the thickness of material being supplied. The specimen may or may not have natural skins on top, bottom, or both surfaces.

29. Number of Specimens

29.1 Test three specimens for each sample. The values reported shall be the mean of those observed. If any value deviates more than 20 % from this mean, test two additional specimens and report the mean for all five values.

30. Procedure

30.1 Measure the area of the cut surfaces in accordance with Section 8 and calculate the area of the cut surfaces.

30.2 Weigh the specimens and submerge under a 3-m (10-ft) head of water (equal to 30 kPa or 4.35 psi) at room temperature (18 to 29°C (65 to 90°F)) for 48 h. Then place the specimens in a stream of air for the minimum time required to remove visible water from the surfaces and reweigh.

NOTE 9—To remove visible and entrapped water from the surface and cut edges, direct a stream of air (using approximately 30 psi air pressure) at the surfaces and cut edges at approximately a 45 degree angle and from the distance of approximately 6 mm (0.25 in.) from the surface for approximately 4 min.

31. Calculation

31.1 Calculate the water absorption, expressed in kg/m² (lb/ft²) of cut surfaces (surfaces without skin or rind) as follows:

$$\text{Water Absorption} = \frac{W_2 - W_1}{A} \quad (3)$$

where:

- W_1 = specimen mass before immersion, kg (lb),
- W_2 = specimen mass after immersion, kg (lb), and
- A = area of cut surface, m² (ft²).

32. Report

32.1 Report the average water absorption in kg/m² (lb/ft²) of the three specimens tested, except as noted in 30.1.

33. Precision

33.1 The repeatability standard deviation has been determined to be 0.007. The reproducibility of this test method is being determined and will be available on or before April 2005. Values of data ranged from 0.034 to 0.055.

Water Absorption, Kg/m²

1	0.0342
2	0.0365
3	0.0412
4	0.0445
5	0.0451
6	0.0457
7	0.0519
8	0.0521
9	0.0544
10	0.0554

Average	0.0461
Standard deviation	0.007

Suffix M—Flammability Ease of Ignition

34. See Test Method D 2863

Suffix R₂ —Energy Absorption

35. See Test Method F 355

- 35.1 Procedure A of Test Method F 355 shall be used.
- 35.2 The impact velocity shall be 3.45 ± 0.17 m/s.

NOTE 910—Approximate drop height is 60 cm (24 in.).

- 35.3 Conduct the test at $23 \pm 2^\circ\text{C}$ ($73.4 \pm 3.6^\circ\text{F}$).
- 35.4 The test specimens shall be 25 mm (1 in.) thick.

Suffix S—Thermal Stability

36. Scope

36.1 This test method covers the determination of dimensional stability of foam in any direction, at elevated temperature.

37. Apparatus

37.1 *Oven*, circulating-air, capable of holding the set temperature to a tolerance of $\pm 1\%$.

38. Test Specimen

38.1 The test specimens shall be 250 by 250 by 25 mm (10 by 10 by 1 in.). Where finished goods with smaller than the specified test specimen are to be tested, the full available dimensions shall be used.

NOTE 101—An alternative test method is to cut 305 by 305-mm (12 by 12-in.) specimens and mark off the 250 by 250-mm (10 by 10-in.) dimensions.

39. Number of Specimens

39.1 A single specimen shall be tested for each sample.

40. Procedure

- 40.1 Determine all three dimensions in accordance with the procedure in Section 8.
- 40.2 Adjust the oven temperature to $70 \pm 2^\circ\text{C}$ ($158 \pm 3^\circ\text{F}$).
- 40.3 Expose the test specimen in the oven at the above temperature for 24 h.
- 40.4 Remove the test specimen and allow to cool at $23 \pm 2^\circ\text{C}$ ($73.4 \pm 3.6^\circ\text{F}$) for 2 h.
- 40.5 Determine all three dimensions at the end of the cooling period.

41. Calculation

41.1 Calculate the dimensional change for each dimension as a percent of original as follows:

$$\% \text{ dimensional change} = \frac{L_f - L_o}{L_o} \times 100 \tag{4}$$

where:

- L_o = original dimension, mm (in.), and
- L_f = dimension at end of test, mm (in.).

42. Report

- 42.1 Report the dimensional change of each direction of interest as a percent of the original dimension.
- 42.2 Report shrinkage as negative values and growth as positive values.

43. Precision

43.1 The repeatability standard deviation has been determined to be 0.44 (length), 0.94 (width), and 0.87 (thickness). The reproducibility of this test method is being determined and will be available on or before April 2005. Values of data ranged from 0 to 3.88 %.

Thermal Stability, %			
	Length	Width	Thickness
1	0	0	1.53
2	0.63	0.83	1.88
3	0.63	0.83	2.57
4	0.63	1.66	3.19
5	1.25	1.67	3.37
6	1.25	1.67	3.45
7	1.25	1.72	3.52
8	1.25	2.5	3.64
9	1.25	2.5	3.88
10	1.25	3.23	4.25
Average	0.939	1.661	3.129
Standard deviation	0.44	0.94	0.87

Suffix T—Tensile Strength and Elongation

44. See Test Methods D 412

44.1 The samples shall be cut using the Die A, as described in Test Methods D 412.

44.2 Test the material in the thickness to be supplied, unless otherwise agreed upon between the purchaser and the supplier.

Suffix V—Thermal Conductivity

45. Test Method A

45.1 See Test Method C 177.

46. Test Method B

46.1 See Test Method C 518.

Suffix W—Density

47. Test Method A

47.1 *Scope*—This test method covers the determination of density of foam by calculation from the mass and volume of a regularly shaped specimen.

47.2 *Test Specimen*—A representative test specimen of regular shape, not less than 16 cm³ (1 in.³) shall be cut from the sample to be tested.

NOTE 1†2—Larger specimens may be necessary when testing coarse cell foams.

47.3 *Number of Specimens*—A single specimen shall be tested for each sample.

47.4 *Procedure*:

47.4.1 Weigh the specimen on a balance or scale graduated so as to permit weighing within ±1 % of the mass to be measured.

47.4.2 Determine the dimensions of the specimen in accordance with Section 8.

47.5 *Calculation*—Calculate the density as follows:

$$D = \frac{m}{v} \quad (5)$$

where:

D = density, kg/m³ (lb/ft³),

m = mass, kg (lb), and

v = volume, m³ (ft³).

47.6 *Report*—Report density to the nearest 1.0 kg/m³ (0.1 lb/ft³).

48. Precision

48.1 The repeatability standard deviation has been determined to be 1.52. The reproducibility of this test method is being determined and will be available on or before April 2005. Values of data ranged from 28.83 to 33.64.

Density, kg/m³
(Test Method A)

2	30.44
3	30.44
4	30.44
5	32.04
6	32.04
7	32.04
8	32.04
9	33.64
10	33.64

Average	31.56
Standard deviation	1.52

49. Test Method B

49.1 *Scope*—This test method covers the determination of the density of closed-cell foams where the volume is determined by a liquid displacement method and mass.

NOTE 123—This test method is particularly appropriate when testing small or irregularly shaped samples.

49.2 *Apparatus:*

49.2.1 *Scale or Balance.*

49.2.2 *Immersion Vessel, as shown in Fig. 1.*

49.2.3 *Receiving Vessel, as shown in Fig. 1.*

49.3 *Test Specimen*—Cut a representative test specimen not less than 16 cm³ (1 in.³) from the sample to be tested.

NOTE 134—Larger specimens may be necessary when testing coarse cell foams or foams with irregular surfaces.

49.4 *Number of Specimens*—Test a single specimen for each sample.

49.5 *Procedure:*

49.5.1 Weigh the specimen on a balance or scale graduated so as to permit weighing within ±1 % of the mass to be measured.

49.5.2 Fill the immersion vessel with liquid until it overflows. Insert the lid in the vessel.

49.5.3 Determine the tare mass of the receiving vessel and, when the flow rate has decreased to less than two drops per minute, place under the overflow spout of the immersion vessel.

49.5.4 Remove the lid, place the test specimen in the immersion vessel, and replace the lid.

49.5.5 When the flow rate has decreased to less than two drops per minute, weigh the receiving vessel.

49.6 *Calculation*—Calculate the density as follows:

$$d = \frac{m_s}{m_f - m_e} \times d_1 \tag{6}$$

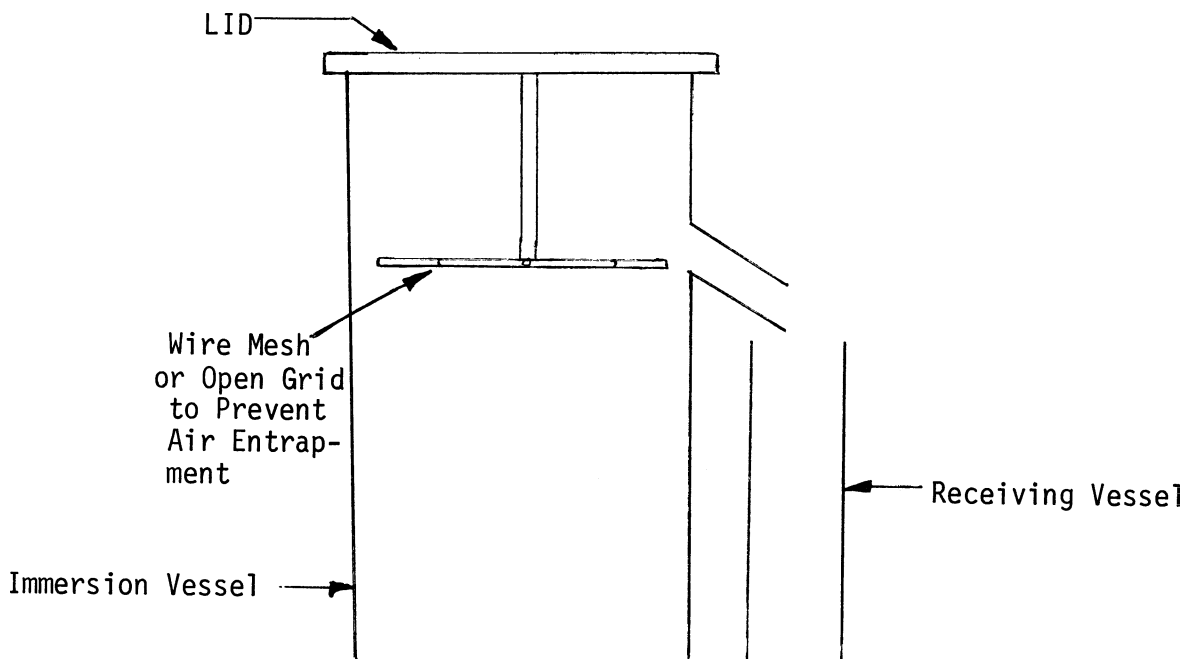

FIG. 1 Apparatus for Density Test Method B

where:

- d = density, kg/m³ (lb/ft³),
- m_s = mass of test specimen, g (lb),
- m_f = mass of receiving vessel and liquid, g (lb),
- m_e = tare mass of receiving vessel, g (lb), and
- d_1 = density of liquid, kg/m³ (lb/ft³).

49.7 *Report*—Report density to the nearest 1.0 kg/m³ (0.1 lb/ft³).

50. Precision

50.1 The repeatability standard deviation has been determined to be 0.47. The reproducibility of this test method is being determined and will be available on or before April 2005. Values of data ranged from 64.1 to 65.6.

	Density, kg/m ³ (Test Method B)
1	64.1
2	65.6
3	65.6
4	65.6
5	65.6
6	65.6
7	65.6
8	65.6
9	65.6
10	65.6
Average	65.6
Standard deviation	0.47

Suffix AA—Buoyancy (Also called Specific Buoyancy)

51. Scope

51.1 This buoyancy test is applicable to closed-cell materials for determining the buoyancy of the foam in fresh water at a standard temperature of 20°C (68°F).

52. Apparatus

52.1 *Scale, Tape, or Gage*, as outlined in Section 8, for determining the density using Test Method A or balance and container as outlined in Section 49 for determining the density using Test Method B.

52.2 *Rigid Tank*, containing fresh water at 20 ± 3°C (68 ± 5.4°F) in which specimens are submerged.

52.3 *Basket(s)*, wire or mesh weighted, to hold specimens in submerged position.

52.4 *Scales*, mounted over the water tank to weigh the basket and specimens while submerged.

53. Test Specimens

53.1 The test specimens shall be 300 by 300 mm (12 by 12 in.) by the thickness of buoyant material furnished.

NOTE 145—It is not advisable to ply up layers because this could cause entrapment of air between the layers giving erroneous results.

54. Number of Specimens

54.1 Test three specimens for each sample. The values reported shall be the mean of those observed. If any value deviates more than 20 % from this mean, test two additional specimens and report the mean for all five values.

55. Procedure

55.1 Determine the volume of each specimen using the procedure described in Section 47 or 49.

55.2 Maintain the water temperature at 20 ± 3°C (68 ± 5.4°F) throughout the test.

55.3 Weigh the inverted, empty basket, including all weights necessary to hold the specimen under water, while submerged to a depth of 50 mm (2 in.).

55.4 Place the specimen under the inverted basket and submerged so the upper surface of the specimen is 50 ± 6 mm (2 ± 0.25 in.) below the surface of the water.

55.5 Submerge the specimen for 24 h and reweigh the submerged basket and specimen without removing them from the water.

55.6 Calculate the fresh water buoyancy as follows:

$$B_m = \frac{W_B - W_s}{V} \quad (7)$$

where:

B_m = measured fresh water buoyancy, kg/m³ (lb/ft³),

- W_B = mass of submerged basket, kg (lb),
 W_s = mass of submerged basket and specimen after 24 h, kg (lb), and
 V = volume of specimen, m³ (ft³).

56. Report

56.1 Report the average fresh water buoyancy of the three specimens tested, except as noted in 54.1.

57. Precision

57.1 The repeatability standard deviation has been determined to be 0.9. The reproducibility of this test method is being determined and will be available on or before April 2005. Values of data ranged from 58 to 60.6.

Buoyancy	
1	58
2	58.4
3	58.5
4	58.7
5	58.9
6	59.3
7	59.7
8	60.2
9	60.3
10	60.6
Average	59.26
Standard deviation	0.9

Suffix BB—Constant Compression Creep

58. Scope

58.1 This test method covers the determination of creep properties of flexible polyolefin foam materials in the form of sheets, boards, or blocks, when subjected to a constant compressive force.

59. Summary of Test Method

59.1 A loaded, movable platen is placed on a test specimen to stimulate static constant compressive loading. By measuring the change in thickness with time, creep properties of the foam material can be obtained.

59.2 The data may be affected by specimen area, thickness, varying ambient conditions of temperature, humidity, vibration, and impact.

60. Apparatus

60.1 The apparatus shall consist of a rigid base plate and a force movable platen. Provisions shall be made for applying a force to the movable platen. The base plate and movable platen shall have minimum dimensions of 180 by 180 mm (4.5 by 4.5 in.). The force shall be applied to the movable platen at a pivot point located at the geometric center of the platen. A dial micrometer shall be attached to the base plate or frame of the apparatus to permit continuous measurements of the travel of the movable platen. Any force-inducing mechanism that does not interfere with measurement of the movement of the movable platen is acceptable. A suitable apparatus is shown in Fig. 2.

61. Test Specimen

61.1 Test specimens shall be right square prisms or right cylinders with minimum area of 25 cm² (4 in.²) and the maximum dimension shall be no greater than the size of the platen in 60.1. The thickness shall not exceed half of the lateral dimensions.

62. Number of Specimens

62.1 Test four specimens for each sample. The values reported shall be the mean of these observed. If any value deviates more than 20 % from this mean, test two additional specimens and report the mean of these six values.

63. Procedure

63.1 Measure the thickness of the specimen in accordance with Section 8. Record this value as the original thickness (T).

63.2 Measure the length and width of the specimen in accordance with Section 8 and record.

63.3 Assemble the apparatus described in Section 53. With the removable platen in contact with the base plate, position the dial micrometer to read thickness at the geometric center of the platen and adjust the micrometer to read zero. Raise the movable platen and center the test specimen under the movable platen on the base plate. Using appropriate means, apply the force agreed upon between the purchaser and the supplier, to the test specimen by placing the standard masses gently on the platen. Measure the total force. Start to measure the thickness of the test specimen while under load 60 ± 5 s after the force has been applied. Record this thickness as the initial thickness under force (T_i).

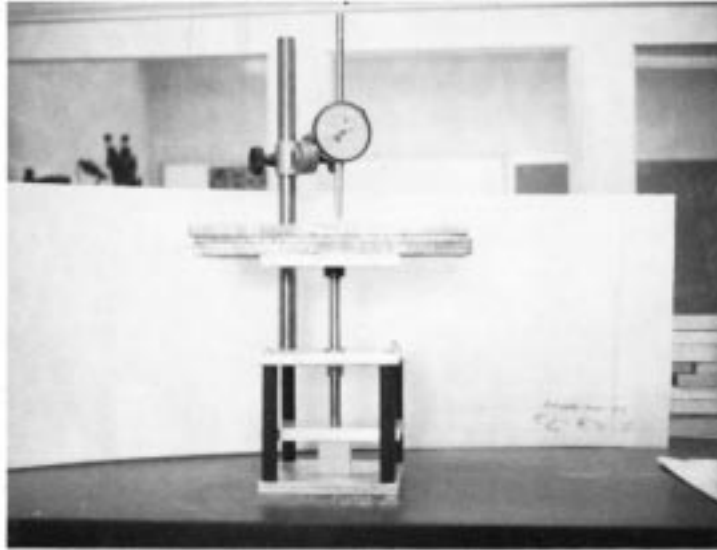

FIG. 2 Creep Test Apparatus

63.4 *Creep Determination*—Measure the thickness of the compressively stressed test specimen at any desired time interval, but at least at 6 min, 1 h, 24 h, and 168 h, after application of the force. More frequent readings are recommended to establish a creep versus time curve. Record the thickness at each specified time interval as the deflection thickness (T_d).

63.5 *Temperature and Humidity*—In order to establish data that will simulate actual conditions of experience, creep may be determined at varied temperatures and humidities. Record the temperature and humidity used.

64. Calculation

64.1 Calculate the static compressive stress in pascals (or pounds-force per square inch) for the given force as follows:

$$\text{Static stress} = \frac{F}{L \times W} \quad (8)$$

where:

- F = applied force, N (or lbf),
- L = length of the specimen, m (or in.), and
- W = width of the specimen, m (or in.).

64.2 Calculate creep based on initial thickness under compressive force as follows:

Creep at any given time interval, %

$$= \frac{(T_i - T_d)}{T_i} \times 100 \quad (9)$$

where:

- T_i = initial thickness under load, mm (in.), and
- T_d = deflection thickness, mm (in.).

65. Report

65.1 Report the following information:

- 65.1.1 Origin and description of material tested,
- 65.1.2 Dates of test,
- 65.1.3 Number of specimens tested,
- 65.1.4 Original dimensions of test specimens,
- 65.1.5 Temperature and humidity used,
- 65.1.6 Static stress, and
- 65.1.7 Plot the average creep of the four specimens tested as a percent of the average initial thickness under load versus time.

Suffix CC—Dynamic Cushioning

66. See Test Method D 1596

66.1 A 345 ± 17 cm/s (135 ± 7 in./s) impact velocity shall be used.

NOTE 156—Approximate drop height 60 cm (24 in.).

66.2 The test shall be conducted at $23 \pm 2^\circ\text{C}$ ($73.4 \pm 3.6^\circ\text{F}$) and $50 \pm 2\%$ relative humidity.

66.3 The test specimen shall be $50 \pm 1.6\text{ mm}$ ($2 \pm 0.063\text{ in.}$).

66.4 The missile mass varies with the sample size and shall be such that it would be equal to 6.9 kPa (1 psi).

66.5 Record the average values for Drops 2 through 5.

67. Precision

67.1 The repeatability standard deviation has been determined to be 0.03 (6 min), 0.11 (60 min), 0.13 (24 h), and 0.18 (168 h). The reproducibility of this test method is being determined and will be available on or before April 2005. Values of data ranged from 1.9 to 2.22 after 168 h.

	Constant Compression Creep			
	6 min	60 min	24 h	168 h
1	0.3	0.6	1.3	1.9
2	0.4	0.8	1.3	2
3	0.4	0.8	1.5	2.1
4	0.4	0.8	1.5	2.2
5	0.4	0.8	1.6	2.2
6	0.4	0.9	1.6	2.3
7	0.4	0.9	1.6	2.3
8	0.4	0.9	1.6	2.3
9	0.4	0.9	1.6	2.4
10	0.4	1	1.7	2.5
Average	0.39	0.84	1.53	2.22
Standard deviation	0.03	0.11	0.13	0.18

68. Keywords

68.1 closed cell materials; flexible cellular; olefin polymers

ASTM International takes no position respecting the validity of any patent rights asserted in connection with any item mentioned in this standard. Users of this standard are expressly advised that determination of the validity of any such patent rights, and the risk of infringement of such rights, are entirely their own responsibility.

This standard is subject to revision at any time by the responsible technical committee and must be reviewed every five years and if not revised, either reapproved or withdrawn. Your comments are invited either for revision of this standard or for additional standards and should be addressed to ASTM International Headquarters. Your comments will receive careful consideration at a meeting of the responsible technical committee, which you may attend. If you feel that your comments have not received a fair hearing you should make your views known to the ASTM Committee on Standards, at the address shown below.

This standard is copyrighted by ASTM International, 100 Barr Harbor Drive, PO Box C700, West Conshohocken, PA 19428-2959, United States. Individual reprints (single or multiple copies) of this standard may be obtained by contacting ASTM at the above address or at 610-832-9585 (phone), 610-832-9555 (fax), or service@astm.org (e-mail); or through the ASTM website (www.astm.org).