



Designation: D 3641 – 97

Standard Practice for Injection Molding Test Specimens of Thermoplastic Molding and Extrusion Materials¹

This standard is issued under the fixed designation D 3641; the number immediately following the designation indicates the year of original adoption or, in the case of revision, the year of last revision. A number in parentheses indicates the year of last reapproval. A superscript epsilon (ϵ) indicates an editorial change since the last revision or reapproval.

1. Scope *

1.1 This practice covers the general principles to be followed when injection molding test specimens of thermoplastic molding and extrusion materials. This practice is to be used to obtain uniformity in methods of describing the various steps of the injection molding process and to set up uniform methods of reporting these conditions. The exact conditions required to prepare adequate specimens will vary for each plastic material. These conditions should become a part of the specification for the material, or be agreed upon between the purchaser and the supplier.

1.2 The methodology presented assumes the use of reciprocating screw injection molding machines. Users of other types of machines will need to adapt this practice to their machines with appropriate precautions.

1.3 The values stated in SI units are to be regarded as the standard. The values given in parentheses are for information only.

1.4 *This standard does not purport to address all of the safety concerns, if any, associated with its use. It is the responsibility of the user of this standard to establish appropriate safety and health practices and determine the applicability of regulatory limitations prior to use.*

NOTE 1—This practice is equivalent to the following parts of ISO 294: Plastics—Injection Moulding of Test Specimens of Thermoplastic Materials²; 294-1: Part 1—General Principles and Multipurpose Test Specimens (ISO Type A Mould) and Bars (ISO Type B Mould)²; ISO 294-2: Part 2—Small Tensile Bars (ISO Type C Mould); ISO 294-3: Part 3—Plates (ISO Type D Moulds).

NOTE 2—Care should be taken in the design of the cavities for tensile test specimens to assure that the flat, parallel test area between the radii extending to the end tabs be of uniform dimensions and cross sectional area for the entire length. With some materials, lack of uniformity in dimensions or cross sectional area, or both, could lead to problems in testing. In these cases, it may be advantageous to slightly thicken the tabs and fillet (radii area) of the specimen.

¹ This practice is under the jurisdiction of ASTM Committee D-20 on Plastics and is the direct responsibility of Subcommittee D20.09 on Specimen Preparation. Current edition approved Dec. 10, 1997. Published May 1998. Originally published as D 3641 – 91. Last previous edition D 3641 – 93.

² Available from American National Standards Institute, 11 West 42nd St., 13th Floor, New York, NY 10036.

2. Referenced Documents

2.1 ASTM Standards:

- D 256 Test Methods for Impact Resistance of Plastics and Electrical Insulating Materials³
- D 570 Test Method for Water Absorption of Plastics³
- D 638 Test Method for Tensile Properties of Plastics³
- D 648 Test Method for Deflection Temperature of Plastics Under Flexural Load³
- D 788 Specification for Methacrylate Molding and Extrusion Compounds³
- D 790 Test Methods for Flexural Properties of Unreinforced and Reinforced Plastics and Electrical Insulating Materials³
- D 883 Terminology Relating to Plastics³
- D 955 Test Method for Measuring Shrinkage from Mold Dimensions of Molded Plastics³
- D 957 Practice for Determining Surface Temperature of Molds for Plastics³
- D 3935 Specification for Polycarbonate (PC) Unfilled and Reinforced Materials⁴
- D 4066 Specification for Nylon Injection and Extrusion Materials⁴
- D 4101 Specification for Propylene Plastic Injection and Extrusion Materials⁴
- D 4181 Specification for Acetal (POM) Molding and Extrusion Materials⁴
- D 4507 Specification for Thermoplastic Polyester (TPES) Materials⁴
- D 4549 Specification for Polystyrene Molding and Extrusion Materials (PS)⁴

2.2 ISO Standards:

- ISO 3167 Plastics—Preparation and Use of Multipurpose Test Specimens²
- ISO 294-1: Plastics—Injection Moulding of Test Specimens of Thermoplastic Materials—Part 1: General Principles and Multipurpose Test Specimens (ISO Type A Mould) and Bars (ISO Type B Mould)²
- ISO 294-2: Plastics—Injection Moulding of Test Specimens of Thermoplastic Materials—Part 2: Small Tensile Bars (ISO Type C Mould)²

³ Annual Book of ASTM Standards, Vol 08.01.

⁴ Annual Book of ASTM Standards, Vol 08.03.

*A Summary of Changes section appears at the end of this standard.

ISO 294-3: Plastics—Injection Moulding of Test Specimens of Thermoplastic Materials—Part 3: Plates (ISO Type D Moulds)²

3. Terminology

3.1 *Definitions*—Definitions of terms applying to this practice appear in Terminology D 883.

3.2 *Definitions of Terms Specific to This Standard:*

3.2.1 *average injection velocity, n*—the mean value of the velocity of the molten plastic flow front within a cavity during the injection time that is calculated from the shot volume and injection time. (See Terminology D 883.)

3.2.1.1 *Discussion*—The average injection velocity is calculated as follows:

$$V_{av} = \frac{V_s}{T_i \times A_c \times n}$$

where:

- V_{av} = average injection velocity, mm/s,
- V_s = shot volume, mm³,
- T_i = injection time, s,
- A_c = cross section of the cavity, mm², and
- n = number of cavities.

The calculation is valid for molds containing a single cavity or those containing identical multi-specimen cavities only and not for family molds.

3.2.2 *cross section of the cavity, n*—in a mold for test specimens, the area of a planar section perpendicular to the flow pattern during filling of the mold that forms the critical portion of the test specimen.

3.2.3 *flash, n*—thin fin of material formed at the parting line of a part during molding, caused by unintentional opening of the mold or by defective mating surfaces.

3.2.4 *switchover point, n*—that point in the injection stage of the injection molding cycle when the control or level of the forwarding force on the screw is switched from that used during injection to that used during pack/hold.

3.2.5 *velocity-pressure transfer point (VPT), n*—that point in the injection stage of the injection molding cycle as defined by pressure, position, or time when the rate of ram travel is switched from speed control to pressure control.

4. Summary of Practice

4.1 Many factors in the injection molding process can have an influence on the character of the moldings and the numerical values of test results. Among these are geometry, size, and temperature conditions of the heating chamber, pressures and speeds used, size, shape, and length of runners and gates, mold temperature and its uniformity, cavity surface finish, and timing cycles used along with the method of sequencing from stage to stage in the process. It is sometimes necessary to pretreat materials before molding. For materials that absorb water this may mean drying under prescribed conditions. This practice attempts to control some of these variables, nullify others, and report those that are necessary to the obtaining of reproducible specimens. Definite stock and mold temperatures, based on the relevant material specifications or the material supplier's recommendations or past experience, and measured by standard techniques, are used for the molding process. By a

sequence of operations the pressures, timing settings, and mode of control are established on the basis of their effects upon the molded part itself rather than upon any universal setpoints.

5. Significance and Use

5.1 It is well known that plastic test specimens molded under different conditions can have significantly different properties. This practice is designed to minimize those differences by establishing operating protocols without being unnecessarily restrictive.

5.2 Always refer to the ASTM material specification or ISO designation for the material for recommended molding conditions. If not available, consult the material supplier.

5.3 This practice requires the use of adequate quantities of plastic material to find desirable operating conditions and to make the desired test specimens.

6. Apparatus

6.1 *Injection Molding Machine*—The machine selected for use must be equipped with appropriate devices for the control and measurement of hydraulic pressure, all relevant temperatures, and the timing of certain cycle elements. Additional devices to monitor cavity pressure and ram position and velocity are very useful in the effective control of the injection molding cycle. The capacity of the machine should be such that the total shot weight (specimens plus sprue and runners) is 20 to 80 % of rated capacity. The injection machine must be capable of maintaining the proper injection velocity range if specified in the material standard.

NOTE 3—Heat-sensitive materials may require using the high end of the 30 to 80 % range in order to minimize residence time of the melt in the barrel.

6.1.1 *Control System*—The various control systems should be able to maintain the operating parameters of the injection molding process from cycle to cycle within the following limits:

plastic melt, or stock temperature	±3°C
mold temperature	±3°C, ≤80°C
	±5°C, >80°C
injection pressure	±2 %
hold pressure	±5 %
injection time	±0.1 s
hold time	±5 %
shot weight	±1 %

Suitable means of monitoring these parameters to ensure control within the above limits should be present.

NOTE 4—The mold temperature may be measured using a calibrated surface pyrometer and the technique described in Practice D 957.

6.1.2 *Screw*—The design of the screw will be determined by the material being molded. A key criterion of screw design is to provide a melt that is as uniform as possible with respect to composition, temperature, and viscosity.

6.1.3 *Clamp*—The clamping force of the machine shall be high enough to prevent flashing at all operating conditions.

NOTE 5—The minimum clamp force required is the product of the highest possible cavity pressure and the projected surface area of the cavities (and runners). A force greater than this minimum will be required to prevent flashing.

6.2 *Mold*—The design of the mold is one of the more



critical variables affecting specimen properties. Optimum reproducibility requires that identical molds be used by parties attempting to obtain comparable results. However, in the absence of identical molds, adherence to certain features of design will help to minimize differences between results obtained by different parties. It has been found that the use of unitized mold bases with interchangeable mold plates and gate inserts can provide a great deal of flexibility and provide rapid transitions between the moldings of different specimen configurations. (See Annex A1.)

6.2.1 Cavity Layout—Multi-cavity molds with identical cavities are recommended. The cavity layout should be such that there is a uniform and symmetrical distribution of specimen surface area on the overall mold surface. The use of single cavity molds is discouraged. For large tensile test specimens and multipurpose bars, a two cavity “Z” or “T” layout is acceptable. For small tensile test specimens and bars, a four cavity double “T” layout is recommended. Other specimens have their unique cavity layout. (See Annex A1.)

NOTE 6—ISO 294-1 states that the “Z” cavity runner layout is preferred over the “T” cavity runner layout.

NOTE 7—Family molds designed to produce more than one part configuration with each shot are not recommended. If molds of this nature are used, consideration should be taken in the design to ensure that constant and uniform filling velocities are achieved in all cavities. Additionally it is cautioned that the comparability of data obtained on specimens molded in this manner may be limited not only to a specific polymer type but also to specific rheological characteristics.

6.2.2 Runners—Runners may be of the full-round type cut into both halves of the mold or of the trapezoidal type cut into only one of the mold halves. They should be a minimum of 5 mm (0.2 in.) in diameter or of equivalent cross-sectional area if trapezoidal. A symmetrical cavity layout will permit identical runner systems to be used for each cavity and thus facilitate uniform filling of all cavities with all materials under all conditions. Runner draft angles for trapezoidal runners should be from 10 to 30°. The diameter of the sprue shall be a minimum of 4 mm on the nozzle side.

NOTE 8—If family molds with two or more identical specimen cavities or non-identical runner systems or if multi-cavity molds with non-identical runner systems are used, specimens from such cavities are to be identified and should not be commingled for testing unless it has been demonstrated that there are no statistically significant differences in test results between the cavities.

6.2.3 Gates—Unless otherwise stated for specific specimens, or material specifications, the gate depth should be at least two-thirds the depth of the bar-type cavities and the gate width should preferably be equal to the width of the bar-type cavities but no less than two thirds the width. Gates should be as short as possible with a maximum length of 3 mm (0.12 in.). Such large gates tend to give parts whose physical properties are less sensitive to varying molding conditions than smaller ones. However, many existing test methods call for somewhat smaller gates such as some of those listed in Table 1. Also certain materials may require small gates to promote shear thinning so that mold cavities can be filled. Details of such gates shall become a part of the injection molding report.

6.2.4 Cavities—Machining tolerances of the cavity will depend on the material to be molded and on the tolerances

TABLE 1 Recommended Gate Sizes for Common Test Specimens

Specimen	Gate Size, mm		Test Method
	Depth	Width	
Type I tension specimen	3.2 by	9.6	D 638
3.2 by 12.7 by 127 mm bar	3.2 by	6.4	D 256, D648, D790
6.4 by 12.7 by 127 mm bar	6.4 by	6.4	D 256, D648, D790
3.2 by 51 mm disk	3.2 by	3.2	D 570
3.2 by 102 mm disk	3.2 by	12.7	D 955
Multipurpose test specimen	2.5 by	14 (min)	ISO 3167

allowed in the specific test methods. Dimensioning of cavities with respect to anticipated shrinkage will result in cavity variations from molder to molder. It also requires different molds for every material to be molded. It is preferred to machine the cavity to the nominal dimensions of the specimen and to adjust the dimensions only when shrinkage leads to a specimen that is out of specification for the desired test method. Draft angles in the sidewalls of the cavity will probably be needed to facilitate part ejection but shall not be greater than 1° except in the shoulder of the multipurpose test specimen (ISO 3167) that shall be not greater than 2°. A maximum draft angle of ½ ° is preferred for all areas. All interior mold surfaces should be finished to Society of Plastics Industry-Society of Plastics Engineers (SPI-SPE) No. A-3 or better. If cavity identification is required, this should be located outside of the test area. It is recommended that the end of an ejector pin be used to incorporate an identifying symbol rather than the cavity surface.

6.2.5 Ejector Pins—Ejector pins shall be located where necessary, but not in the test area of the specimen. For tensile test specimens, it is recommended that the ejector pins be located at the wide tab ends (shoulders). For universal bars, it is recommended that the ejector pins be located at the “dead” end of the bar and outside of the central 20 mm length of the ISO mold type B (80 mm bar). For plates, the ejector pins should be outside the central area of 50 mm diameter.

6.2.6 Cavity Pressure Transducers—Pressure transducers may be mounted in conjunction with an ejector pin or directly into the cavity, coplanar to the mold surface. These may be used to monitor or control the mold filling characteristics. In the case of plates, the pressure transducer is mandatory for measurement of molding shrinkage only and the mounting shall be as shown for ISO mold type D in Annex A1. Transducers may also be located in the main runner but this location will not provide suitable data for monitoring or controlling cavity flow.

6.2.7 Molding Cooling—Coolant channels shall be designed so as to limit point-to-point surface temperature differences to a maximum of 5°C. The channels should be located in such a way that each of the cavities is cooled in an identical manner. Although this may not be possible with non-symmetrical family molds, it is a design criterion that should be followed as closely as possible.

NOTE 9—Fittings used to connect the coolant channel openings to the recirculating system may be of the self-sealing quick-disconnect type. For maximum cooling efficiency the flow of coolant through the channels should be turbulent, as indicated by a Reynolds number >5000.

7. Procedure

7.1 *Consistency of Test Specimens*—Consistent test specimens can only be obtained when operating on an automatic cycle with adequate control of the parameters listed in 6.1.1.

7.2 *Feed*—Condition plastic material prior to molding as required in the relevant material standard or according to the material supplier's recommendation if no standard covers the material. In the case of extreme moisture sensitivity, maintain drying conditions in the molding machine feed hopper itself. Avoid exposing material to an atmosphere with temperatures significantly below ambient temperature to prevent condensation of moisture onto plastic material.

7.3 *Setting Molding Conditions*—Set molding conditions as specified in the relevant material standard, or according to the material supplier recommendations, if available. The molding conditions that are critical are melt temperature, mold temperature and average injection velocity. Others that may be specified include first and second stage injection pressure, and screw back pressure; first and second stage injection times; cure/cool, mold open, melt decompression and total cycle times; screw rotation speed and cushion/pad interval.

7.3.1 *Melt Temperature*—Choose a melt, or stock temperature based on the relevant material standard, or the recommendations of the material supplier, or best available information. Adjust the barrel temperature controller setpoints in order to obtain the desired melt temperature. These settings will typically be lower than the aim melt temperature. Measure this temperature on cycle after thermal equilibrium has been reached by actually taking the temperature of a free shot (minimum volume of 30 ccm) with a needle-type pyrometer having an accuracy of $\pm 2.0^{\circ}\text{C}$ (3.8°F). Move the needle about constantly in the plastic mass and make a sufficient number of measurements to establish a reliable average. Preheating of the needle to near the measured temperature will allow faster, and thus more reliable measurements to be made. Perform frequent checks. The melt temperature may alternatively be measured by means of a suitable temperature sensor in the molten plastic flow stream provided the values obtained are the same as those by the free shot method.

NOTE 10—Under a fixed set of operating conditions of cycle and shot size there will generally be a constant difference between the observed plastic temperature and the cylinder-wall temperature or the setpoint temperature. This difference will vary as conditions are changed.

7.3.2 *Mold Temperature*—Choose a mold temperature based on the relevant material standard or the supplier's recommendation. The temperature should be measured with a surface-type pyrometer to an accuracy of $\pm 2.0^{\circ}\text{C}$ (3.8°F) after the system has obtained thermal equilibrium and immediately after opening the mold and ejecting the part. Carry out measurements of the mold cavity surface temperature at several points on both the moveable and stationary mold halves. The molding process shall be recycled a minimum of ten cycles between each set of multiple readings. Calculate the mold temperature as an average of these readings.

7.3.3 *Average Injection Velocity*—Unless otherwise specified, an average injection velocity of 200 ± 100 mm/s is suitable for most materials in preparing tensile specimens and bars. For other specimens, average injection velocity is chosen

to give similar fill times as with tensile and bar specimens.

7.3.4 *Molding Pressures*—Most injection molding machines use hydraulic pressure as the motive force for the various machine movements. In different machines valves are used to control the level of pressure, the flow rate of fluid, the length of time at a given pressure, or combinations of these parameters. Filling of the mold is typically done with a high pressure (first stage) in order to achieve the desired short fill times. However, since this high pressure may cause flashing of the mold after the cavity is filled, and since release of the pressure after filling would allow polymer to flow out of the mold, a usually lower second stage, or hold pressure, is begun when the mold is essentially filled. The point in the cycle when this transition is made is called the "switchover point" or the velocity-pressure transfer point in those machines where the first stage is speed controlled. Control of these functions is done using a variety of means involving timers, position sensors, pressure transducers, or combinations thereof.

7.3.4.1 *First Stage Injection Pressure*—After choosing a melt and mold temperature from the relevant material specification or by other means the first stage injection pressure may be determined by the following procedure. Set the second stage pressure to zero and incrementally increase the first stage pressure from an obviously low value where long fill times and incompletely filled cavities occur until the fill time is reduced to its target value and the cavities are filled. The readouts on the timer, position sensor, or pressure transducer should be noted as control parameters for the final cycle. Maintain as constant a screw forward speed during the injection period as possible.

7.3.4.2 *Second Stage Injection Pressure*—Having chosen the melt and mold temperatures, the first stage injection pressure and its means of control, set the second stage pressure by adjusting the second stage pressure upward until a satisfactory part is produced. This is indicated mainly by surface appearance, that is, lack of sink marks, voids, flash, etc. Second stage pressure should be maintained constant until polymer in the gate of the cavity is sufficiently cool so that flow through the gate is no longer possible or the "gate freezes." This can be determined by increasing the setpoint of the timer until a constant part weight is obtained.

7.3.4.3 *Back Pressure*—After the second stage time has expired the screw will begin to rotate to plasticate the polymer for the next injection cycle. As melted polymer is forwarded to the barrel ahead of the screw the screw will backup against the imposed back pressure. High back pressure will cause excessive working of the polymer, high melt temperatures, and drooling of polymer from the nozzle. It will also cause breakdown of any fibrous fillers. Low back pressure may cause unmelted polymer or nonuniform polymer temperatures or inadequately mixed polymers where additives are used. Choose a back pressure that avoids the difficulties of the extremes described.

7.3.5 *Molding Cycle*—Injection-molding machines of different types and produced by different manufacturers have different means of controlling the molding cycle. Fig. 1 illustrates the interplay of the different components of the cycle. Certain ones of these will be controlled by various means on the different machines. Although the cooling and

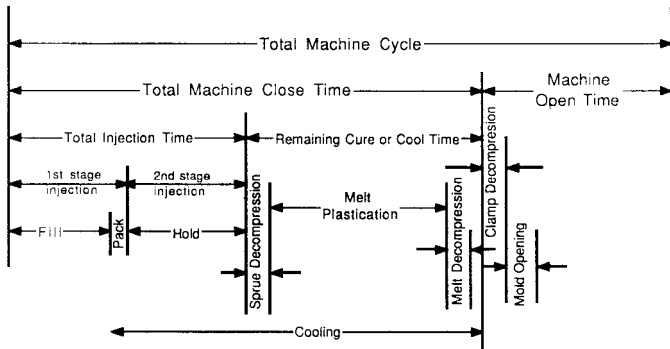

FIG. 1 Molding Cycle Components

melt plastication functions may affect the properties of test specimens, the most important function to control is the injection step. The driving force in the injection step is commonly hydraulic pressure. Different machines and control systems will control this force with valves actuated by timers, pressure setpoints, position transducers, etc. Whichever method of control is used, it will require reproducible fill timers (± 0.1 s) to achieve reproducible parts. In general, the minimum practical fill time is desired.

7.3.5.1 First Stage and Second Stage—Set the available means of control, including screw position, cavity pressure, screw pressure, and timer, to the value determined during manipulation of the injection pressures as described in 7.3.5.1 and 7.3.5.2.

7.3.5.2 Cure/Cool Time—Choose a cooling time that will allow the part to be ejected from the mold without distortion. A longer cooling time will have the adverse effect of increasing the melt residence time in the barrel.

7.3.5.3 Screw Rotation Speed—Choose a minimum screw speed in order to use nearly all of the time available during the cure/cool part of the cycle. Slower screw speeds generally provide greater uniformity of the melt with respect to viscosity and temperature.

7.3.5.4 Cylinder Decompression—Most injection machines will decompress the melt after plastication by a further small retraction of the screw after rotation has ceased. This is controlled by either a position sensor or a timer. Set the available means to the lowest setting that will eliminate drool from the nozzle when the carriage is subsequently pulled away from the mold prior to mold opening.

7.3.5.5 Mold Open Time—Choose a time that will allow the mold faces to part, the ejection mechanism to occur, and the part to safely fall out. It is advisable to allow a safety factor so that minor problems during ejection will not cause interruption of the cycle.

7.3.5.6 Total Cycle Time—Measure the total cycle time with a stopwatch between the same point of successive cycles.

7.3.6 Cushion/Pad—It is important to provide a small amount of excess melt in front of the screw so that it never fully completes the injection stroke of which it is capable and

so that the full pressure of the ram is exerted on the molten material. This is referred to as the “cushion” or “pad” and is usually measured by its length in the barrel. It is important that this cushion be kept uniform from one cycle to the next. A minimum length of 3 mm is generally needed and it should not exceed 6 mm.

7.4 Begin to collect specimens only after molding cycle equilibrium has been achieved.

7.5 Allow test specimens removed from the mold to cool gradually and uniformly to room temperature in order to avoid differences in test results due to treatment of individual specimens. For materials sensitive to atmospheric exposures, specimens should be protected by storing in impermeable containers.

8. Report

8.1 Report the following information:

- 8.1.1 Date, place, and time of molding,
- 8.1.2 Description of material being molded (type, grade, color, lot number),
- 8.1.3 Pre-molding treatment of material,
- 8.1.4 Identification of the mold being used (type, number of cavities),
- 8.1.5 Type and number of specimens molded,
- 8.1.6 Description of the cavity gating,
- 8.1.7 Make, size (clamp and shot capacity), and type of machine used,
- 8.1.8 Weight of shot (including sprues and runners), and weight of specimen,
- 8.1.9 All temperature controller setpoints,
- 8.1.10 Temperatures, including:
 - 8.1.10.1 Melt temperature,
 - 8.1.10.2 Mold temperature, stationary half, and
 - 8.1.10.3 Mold temperature, fixed half,
- 8.1.11 Pressures, including:
 - 8.1.11.1 First stage injection pressure and
 - 8.1.11.2 Second stage injection pressure,
 - 8.1.11.3 Back pressure,
- 8.1.12 Molding cycle times, including:
 - 8.1.12.1 First stage injection time (s),
 - 8.1.12.2 Second stage injection time (s),
 - 8.1.12.3 Cure/cool time (s),
 - 8.1.12.4 Mold open time (s),
 - 8.1.12.5 Melt decompression time (s) or distance (mm),
 - 8.1.12.6 Total cycle time (s),
- 8.1.13 Screw speed (r/min),
- 8.1.14 Cushion/pad, and
- 8.1.15 Average injection velocity.

9. Keywords

9.1 injection-molding; mold design; test specimen preparation; thermoplastics

A1.

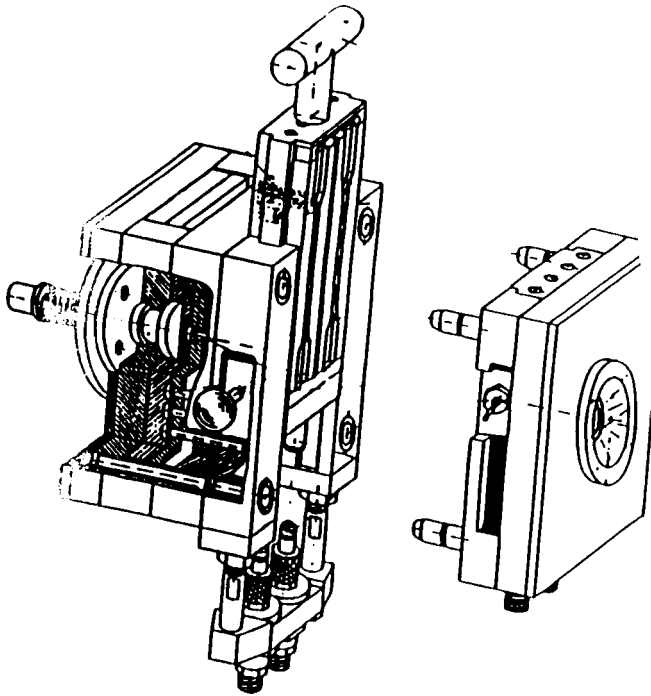

FIG. A1.1 Example of a Unitized Mold Base With Interchangeable Two Cavity Tensile Bar Insert

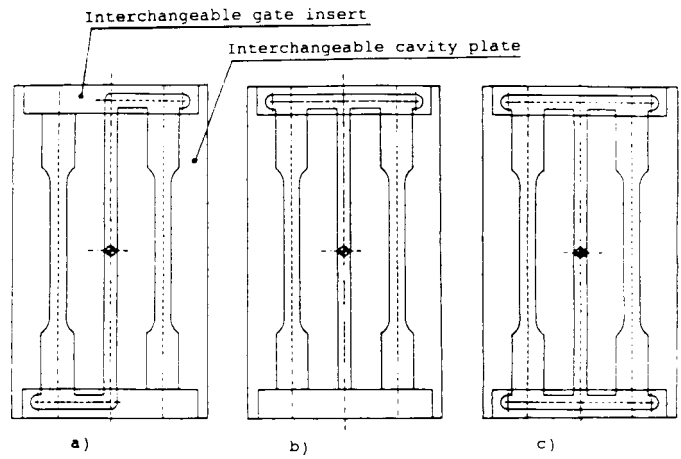
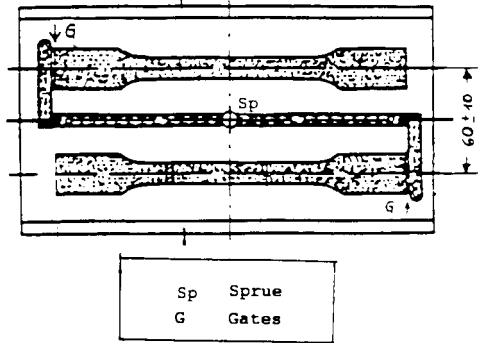

FIG. A1.2 Cavity Layout for Large Tensile Specimens

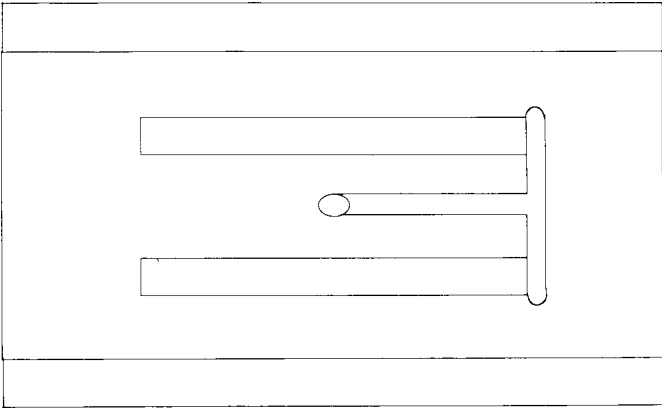

FIG. A1.3 Cavity Layout for Large Bars

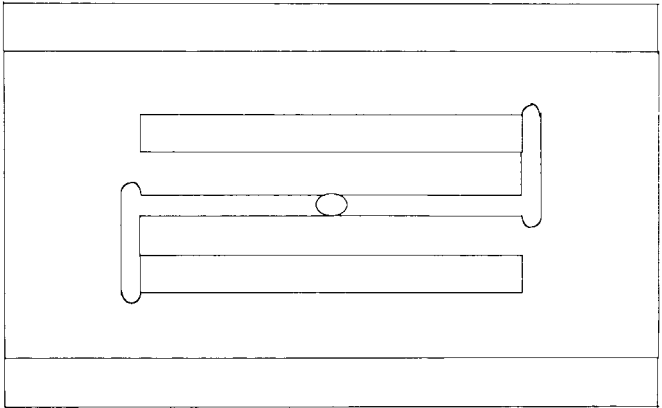

FIG. A1.4 Cavity Layout for Small Bars

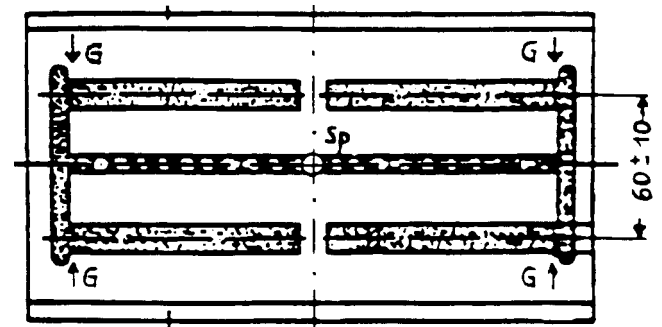

FIG. A1.5 Cavity Layout for Small Tensile Bars

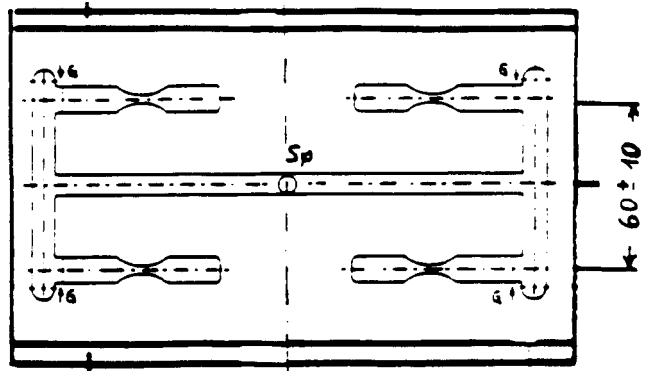

FIG. A1.6 Cavity Layout for Plates

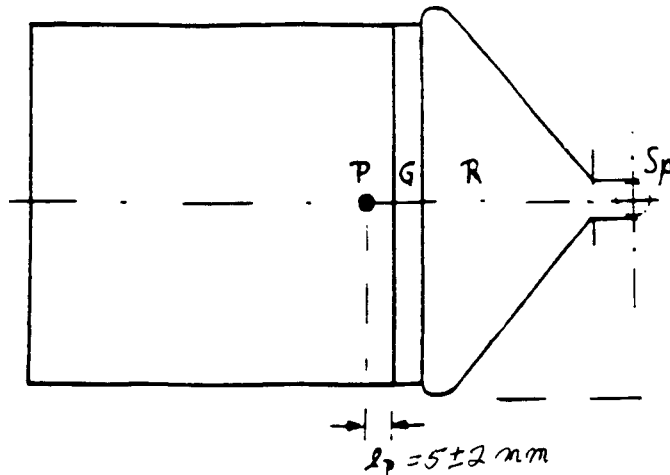

FIG. A1.7 Pressure Sensor Location in Plate Specimen for Evaluating Shrinkage from Molds for Plastics

APPENDIX

(Nonmandatory Information)

X1. SUGGESTED PROCEDURE FOR MOLDING CYCLE SETUP

X1.1 *Reciprocating Screw Machine with Timing, Pressure, and Position Controls:*

X1.1.1 *Temperatures*— Choose melt and mold temperatures as described in 7.3.

X1.1.2 *First Stage Injection*—Certain machine controls may allow first stage injection to be programmed into as many as ten segments. The ability of the machine to respond to large variations in the programmed input is questionable and will certainly vary with different materials, etc. This in turn will lead to specimen variations. The best procedure is to fill as much of the part as possible at a constant velocity. Choose a velocity profile that will get the ram up to the aim velocity as quickly as possible without too much overshoot. This is related to the responsiveness of the machine controls and thus needs to be determined experimentally. Choose an injection velocity that will fill the part in the desired time by setting the hold pressure to “0” and then adjusting the available means of setting the “switchover” point until an almost-full part is obtained. A too-slow injection velocity will result in hydraulic pressure demands at the end of the cycle beyond the machine’s capabilities due to the viscosity increase of the cooling melt in the cavity. A too-fast injection velocity will be difficult to stop and may overpack the cavity and cause flash or even damage the mold. Significant property variations can come from this part of the cycle and thus it is important to be able to repeat, reproduce, and describe it. After this preliminary choice of an injection velocity is made, and the parameters discussed below are chosen, adjustments may be made to achieve exactly the fill time desired.

X1.1.3 *Velocity-Pressure-Transfer*—Significant property variations can result from the choice of the velocity-pressure-transfer (V-P-T) point as well as the means by which it is controlled. For the sake of uniformity and reproducibility it

should be as near the end of fill as possible.

NOTE X1.1—Maximum properties will not be obtained by a choice of V-P-T at the end of fill, but it is undoubtedly the best way to standardize this important choice.

X1.1.3.1 *Velocity-Pressure-Transfer by Position*—Set the hold pressure to “0,” the injection velocity profile and velocity as in X1.1.2, and incrementally adjust the V-P-T position until the initial short shot part is 95 to 98 % filled. If this adjustment reduces the cushion to too small a value, the screw fill setpoint will need to be increased to allow a larger shot size with an adequate cushion.

NOTE X1.2—The advantage of position control is that it is not coupled to other variables and that an equal volume of material is thus injected with each shot, and that V-P-T therefore occurs at the same degree of fill each time. This, however, does assume that the screw fill is the same each time. This in turn may be affected by the screw r/min during fill and the length of time allowed for the fill part of the cycle. Monitor the screw fill point as frequently as necessary to ensure the accuracy of this parameter.

NOTE X1.3—The 95 to 98 % fill suggestion is intended to merely indicate a part that is nearly filled but visibly short. In a part that is 170 mm in length, this may correspond to a part that is 3 to 7 mm short.

X1.1.3.2 *Velocity-Pressure-Transfer by Cavity Pressure*—Set the hold pressure to “0” and the injection velocity profile and injection velocity as in X1.1.2. The exact location of the cavity pressure transducer will strongly affect the setpoint used. As in X1.1.3.1, increase the cavity pressure setpoint until the nearly full part described in Note X1.3 is obtained. Adjust this parameter while the machine is running on cycle so that on-cycle melt and mold temperatures will prevail during the adjustment. Be aware that adjustments of the injection velocity or any of the temperatures will affect the pressure at the point of filling when V-P-T is desired.

X1.1.3.3 *Velocity-Pressure-Transfer by Time*—This method of control is the least preferred in that almost any conceivable

variation in the cycle parameters will affect the length of time required to fill the part to the desired V-P-T point. With hold pressure and injection velocity as in X1.1.3.1 and X1.1.3.2, increase the injection time setpoint until the nearly full part is obtained.

X1.1.4 Hold Pressure— With the injection velocity and the V-P-T determined as described above, increase the hold pressure setpoint until a fully packed part is obtained. This is determined by the absence of short shot, sink marks, and other visual defects.

X1.1.5 Hold Pressure Time—The hold pressure must be maintained until the gates of the part have frozen and there can thus be no further flow of material either into or out of the mold. If cavity pressure near the gate can be monitored, this point in time can be determined by observing when the cavity pressure begins to decrease despite the presence of hold pressure. If cavity pressure cannot be monitored, increase the hold time until a constant part weight is obtained. Several parts should be weighed at each timer setting to ensure that adequate time is allowed without unduly extending the overall cycle.

X1.1.6 Cooling Time— Increase the cooling timer setpoint until the part can be ejected without damage at the ejector pin locations and until the part does not distort after ejection. It may be necessary to extend this time to allow the screw to refill

in a controllable manner as this action occurs concurrently. It is better to allow a safety margin with this parameter than to have problems that interrupt the cycle during sample preparation.

X1.1.7 Melt Plastication—After the gates have frozen, the hold pressure can be released. Then, while the part is cooling in the mold, and with the barrel nozzle in contact with the sprue bushing, the screw can begin to refill. Set the screw speed just high enough so that it will refill to the set position in slightly less than the time allowed by the cooling period. Slower screw speeds will generally provide greater uniformity of the melt with respect to viscosity and temperature. The back-pressure during refill provides a resistance to the pumping of melt into the barrel area in front of the screw tip. High back-pressure settings will force the screw to work the material more and thus generate higher temperatures. Low settings with short cycle times may lead to inadequately melted injection shots. Observation of either phenomenon should lead to adjustments. In general, back pressures of 0.5 to 1.5 MPa (70 to 220 psi) may be used.

X1.1.8 Mold Open Time— Set this machine timer control so as to allow the part to be ejected and fall cleanly out of the mold open area. It is better to allow extra time for this operation than to have to interrupt the cycle to remove jammed parts.

SUMMARY OF CHANGES

This section identifies the location of selected changes to this test method. For the convenience of the user, Committee D-20 has highlighted those changes that may impact the use of this test method. This section may also include descriptions of the changes or reasons for the changes, or both.

D 3641 – 97:

- (1) Harmonized with ISO 294-1, -2, and -3.
- (2) Added 4 mm test specimens (ISO mould types A, B, C and D).
- (3) Included average injection velocity.

- (4) Included unitized mold bases.
- (5) Added Annex 1 Annex A1 and examples Figs. A1.1-A1.7 to show preferred specimen layout in the mold.
- (6) Document was completely reviewed.

ASTM International takes no position respecting the validity of any patent rights asserted in connection with any item mentioned in this standard. Users of this standard are expressly advised that determination of the validity of any such patent rights, and the risk of infringement of such rights, are entirely their own responsibility.

This standard is subject to revision at any time by the responsible technical committee and must be reviewed every five years and if not revised, either reapproved or withdrawn. Your comments are invited either for revision of this standard or for additional standards and should be addressed to ASTM International Headquarters. Your comments will receive careful consideration at a meeting of the responsible technical committee, which you may attend. If you feel that your comments have not received a fair hearing you should make your views known to the ASTM Committee on Standards, at the address shown below.

This standard is copyrighted by ASTM International, 100 Barr Harbor Drive, PO Box C700, West Conshohocken, PA 19428-2959, United States. Individual reprints (single or multiple copies) of this standard may be obtained by contacting ASTM at the above address or at 610-832-9585 (phone), 610-832-9555 (fax), or service@astm.org (e-mail); or through the ASTM website (www.astm.org).