



Designation: D 3846—~~94~~ — 02

Standard Test Method for In-Plane Shear Strength of Reinforced Plastics¹

This standard is issued under the fixed designation D 3846; the number immediately following the designation indicates the year of original adoption or, in the case of revision, the year of last revision. A number in parentheses indicates the year of last reapproval. A superscript epsilon (ϵ) indicates an editorial change since the last revision or reapproval.

This standard has been approved for use by agencies of the Department of Defense.

1. Scope*

1.1 This test method covers the determination of the in-plane shear strength of reinforced thermosetting plastics in flat sheet form in thicknesses ranging from 2.54 to 6.60 mm (0.100 to 0.260 in.).

1.2 The values stated in SI units are to be regarded as the standard. The values given in parentheses are for information only.

1.3 *This standard does not purport to address all of the safety concerns, if any, associated with its use. It is the responsibility of the user of this standard to establish appropriate safety and health practices and determine the applicability of regulatory limitations prior to use.*

NOTE 1—This standard has no known ISO equivalent.

2. Referenced Documents

2.1 *ASTM Standards:*

¹ This test method is under the jurisdiction of ASTM Committee D-20 on Plastics and is the direct responsibility of Subcommittee D20.18 on Reinforced Thermosetting Plastics.

Current edition approved ~~June 15, 1994~~, March 10, 2002. Published ~~August 1994~~, May 2002. Originally published as D 3846 – 79. Last previous edition D 3846 – 93.

*A Summary of Changes section appears at the end of this standard.

- D 618 Practice for Conditioning Plastics and Electrical Insulating Materials for Testing²
- D 695 Test Method for Compressive Properties of Rigid Plastics²
- D 2344 Test Method for Apparent Interlaminar Shear Short-Beam Strength of Parallel-Fiber Composites by Short-Beam Method
Polymer Matrix Composite Materials and Their Laminates³
- E 4 Practices for Load Force Verification of Testing Machines⁴
- E 691 Practice for Conducting an Interlaboratory Study to Determine the Precision of a Test Method⁵

3. Terminology

3.1 Definitions:

3.1.1 *in-plane shear strength*—the shear strength at rupture in which the plane of fracture is located along the longitudinal axis of the specimen between two centrally located notches machined halfway through its thickness on opposing faces.

4. Summary of Test Method

4.1 In-plane shear strength, as determined by this test method, is measured by applying a compressive load to a notched specimen of uniform width. The specimen is loaded edgewise in a supporting jig of the same description as that referenced in Test Method D 695 for testing thin specimens. A schematic of the specimen used for this test and the supporting jig is shown in Fig. 1. Failure of the specimen occurs in *shear* between two centrally located notches machined halfway through its thickness and spaced a fixed distance apart on opposing faces.

5. Significance and Use

5.1 Shear tests of various kinds are widely used in the reinforced plastics industry to assess the strength of the reinforcement-to-resin bond in polyester-, vinyl ester-, and epoxy-resin composites. In addition to their importance for the generation of data for research and development, quality control, and specification purposes, such tests are of fundamental value to the fibrous reinforcement industry, since they can be used to assess the potential of new sizing systems for the surface treatment of glass fibers.

5.2 This test method is useful for establishing the shear strength of laminates or other reinforced plastics having randomly dispersed fiber reinforcement. While the test also lends itself to parallel-fiber reinforced plastics, it has been designed to accommodate nonparallel-fiber reinforced materials that cannot be tested satisfactorily by the short-beam procedure described in Test Method D 2344.

² Annual Book of ASTM Standards, Vol 08.01.
³ Annual Book of ASTM Standards, Vol 15.03.
⁴ Annual Book of ASTM Standards, Vol 03.01.
⁵ Annual Book of ASTM Standards, Vol 14.02.

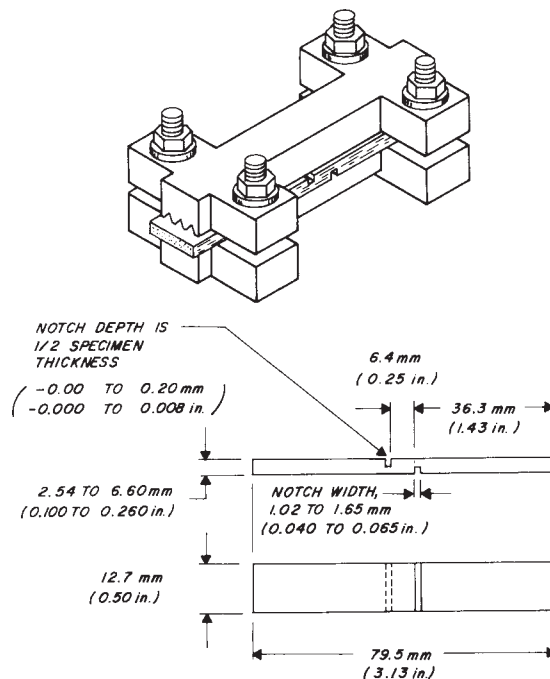

FIG. 1 Specimen and Loading Jig for In-Plane Shear Test

6. Apparatus

6.1 *Testing Machine*—Any suitable testing machine capable of control of constant-rate-of-crosshead movement and comprising essentially the following:

6.1.1 *Drive Mechanism*—A drive mechanism for imparting to the movable member a uniform, controlled velocity with respect to the stationary member, as required in 10.3.

6.1.2 *Load Indicator*—A load-indicating mechanism capable of showing the total compressive load carried by the test specimen. The mechanism shall be essentially free of inertial lag at the specified rate of testing and shall indicate the load with an accuracy of $\pm 1\%$ of the maximum indicated value of the test (load). The accuracy of the testing machine shall be verified at least once a year in accordance with Practices E 4.

6.1.3 *Compression Tool*—A compression tool for applying the load to the test specimen, such as those shown in Figs. 1 and 2 of Test Method D 695.

6.1.4 *Supporting Jig*—A supporting jig, shown schematically in Fig. 1, and conforming to the dimensions of that shown in Fig. 4 of Test Method D 695.

6.1.5 *Micrometers*—Suitable micrometers, reading to 0.025 mm (0.001 in.) for measuring the width and thickness of the specimens, as well as the depth of, and distance between, the notches.

6.1.6 *Torque Wrench*—A suitable torque wrench for tightening the nuts of the supporting jig of 6.1.4 to the torque prescribed in 10.2.

7. Test Specimens

7.1 *Configuration*—Test specimens shall conform to the shape and dimensions given in Fig. 1. The edges of the specimens shall be smooth, but not rounded or beveled.

7.2 *Preparation*—Two parallel cuts, one on each opposite face of the specimen and 6.4 mm (0.25 in.) apart, shall be sawed across the entire width of the specimen and centrally located along its length. The width and depth of notch shall conform to the dimensions shown in Fig. 1. For laminated materials, the notch shall be of sufficient depth to sever the center ply of the reinforcement, located midway between the two faces of the laminate.

7.3 *Number*—Five specimens shall be tested whenever isotropic materials are under test. When testing material that is suspected or known to be anisotropic, ten specimens (five normal to and five parallel with the principal axis of anisotropy) shall be tested.

8. Conditioning

8.1 *Conditioning*—Condition the test specimens at $23 \pm 2^\circ\text{C}$ ($73.4 \pm 3.6^\circ\text{F}$) and $50 \pm 5\%$ relative humidity for not less than 40 h prior to test in accordance with Procedure A of Practice D 618, for those tests where conditioning is required. In case of disagreement, the tolerances shall be $\pm 1^\circ\text{C}$ ($\pm 1.8^\circ\text{F}$) and $\pm 2\%$ relative humidity.

8.2 *Test Conditions*—Conduct tests in the standard laboratory atmosphere of $23 \pm 2^\circ\text{C}$ ($73.4 \pm 3.6^\circ\text{F}$) and $50 \pm 5\%$ relative humidity, unless otherwise specified. In cases of disagreement, the tolerances shall be $\pm 1^\circ\text{C}$ ($\pm 1.8^\circ\text{F}$) and $\pm 2\%$ relative humidity.

9. Speed of Testing

9.1 Speed of testing shall be the relative rate of motion of the grips or test fixtures during the test. Rate of motion of the driven grip or fixture when the machine is running idle may be used if it can be shown that the resulting speed of testing is within the limits of variation allowed.

9.2 The standard speed of testing shall be 1.3 ± 0.3 mm/min (0.050 ± 0.010 in./min).

10. Procedure

10.1 Measure the width of the specimen between the notches to the nearest 0.025 mm (0.001 in.).

10.2 Mount the specimen in the supporting jig (Fig. 1) so that it is flush with the base and centered. Tighten the nuts of the jig with the torque wrench of 6.1.6 to a torque of $0.113 + 0.000, - 0.028$ N·m ($1.00 + 0.00, - 0.25$ lbf-in.). Place the assembly in the compression tool described in 6.1.3.

10.3 Set the speed control at 1.3 mm/min (0.050 in./min) and start the machine.

10.4 Record the maximum load carried by the specimen during the test. (Usually this will be the load at the moment of rupture.)

10.5 Determine the length of the failed (sheared) area to the nearest 0.025 mm (0.001 in.) by measurement of this surface with respect to either half of the ruptured specimen. This technique affords the most accurate determination of the length of the sheared plane defined by the separation of the notches machined in the specimen.

11. Calculation

11.1 *In-Plane Shear Strength*—Calculate the in-plane shear strength by dividing the maximum shear load carried by the specimen during the test by the product of the width of the specimen (see 10.1) and the length of the failed area, as determined in 10.5. Express the result in megapascals or pounds-force per square inch and report it to three significant figures.

12. Report

12.1 Report the following information:

- 12.1.1 Complete identification of the material tested, including type, source, manufacturer's code number, form, principal dimensions, previous history, etc.,
- 12.1.2 Method of preparing test specimens,
- 12.1.3 Conditioning procedure used,
- 12.1.4 Atmospheric conditions in test room,
- 12.1.5 Number of specimens tested,
- 12.1.6 A brief description of the type of testing machine used, and the date on which it was last verified (see 6.1.2) and by whom,
- 12.1.7 In-plane shear strength, average value, and standard deviation, and
- 12.1.8 Date of test.

13. Precision and Bias

~~13.1 This test method does not yet contain~~

~~13.1 Table 1 is based on a numerical precision and bias statement and it shall not be used as a referee method round robin conducted in case of dispute. The precision and bias of this test method is under investigation by Subcommittee D20.18. Those wishing to participate 2001 in this work may contact accordance with Practice E 691, involving two materials tested by five laboratories. For each material, all the C samples were prepared at one source, but the individual specimens were prepared at the laboratories which tested them. Each test result was the average of D20.18, ASTM, 100 Barr Harbor Drive, West Conshohocken, PA 19428-2959. five individual determinations. Each laboratory obtained four test results for each material.~~

~~NOTE 2—A preliminary study 2—Caution: The explanation of repeatability has indicated that "r" and "R" in 13.2.1 and 13.2.2 are only intended to present a meaningful way of considering the percent coefficient approximate precision of this test method. The data in Table 1 should not be applied to acceptance or rejection of materials, as these data apply only to the materials tested in the round robin and are unlikely to be rigorously representative of other lots, formulations, conditions, materials, or laboratories. Users of this test method should apply the principles outlined in Practice E 691 to generate data specific to their materials and laboratory (or between specific laboratories). The principles of 13.2-13.2.2 would then be valid for such data.~~

~~13.2 Concept of "r" and "R" in Table 1—If S_r and S_R have been calculated from a large enough body of data, and for test results that were averages from testing five specimens for each test result, then:~~

~~13.2.1 Repeatability:~~

~~Two results obtained within one laboratory shall be judged not equivalent if they differ by more than the "r" value for that material. "r" is the interval representing the critical difference between two test results for the same material, obtained by the same operator using the same equipment on the same day in the same laboratory.~~

~~13.2.2 Reproducibility:~~

~~Two test results obtained by different days was estimated to laboratories shall be 5.2%. The coefficient of variation judged not equivalent if they differ by more than the "R" value for that material. "R" is the interval representing the critical difference between two test results obtained on for the same material, obtained by different operators using different equipment in different laboratories.~~

~~13.3 Any judgement in accordance with 13.2.1 or 13.2.2 would have an approximate 95% (0.95) probability of being correct.~~

~~13.4 There are no recognized standards by which to estimated bias of 5.2%his method.~~

14. Keywords

- 14.1 compressive shear; in-plane shear; plastics; reinforced plastics

SUMMARY OF CHANGES

This section identifies the location of selected changes to this test method. For the convenience of the user, Committee D20 has highlighted those changes that may impact the use of this test method. This section may also

TABLE 1 Precision Statement for In-Plane Shear

Material	Mean	S_r^A	S_R^B	r^C	R^D
Vinyl Ester	3042	775	1241	2171	3474
Polyester	2898	710	1296	1989	3631

^A S_r = within laboratory standard deviation for the indicated material. It is obtained by pooling the within-laboratory standard deviations of the test results for all of the participating laboratories:

$$S_r = \left[\frac{(S_1)^2 + (S_2)^2 + \dots + (S_n)^2}{n} \right]^{1/2}$$

^B S_R = between-laboratories reproducibility, expressed as standard deviation:

$$S_R = \left[S_r^2 + S_r^2 \right]^{1/2}$$

where S_r = standard deviation of laboratory means.

^C r = within-laboratory critical interval between tow test results = $2.8 \times S_r$.

^D R = between-laboratories critical interval between tow test results = $2.8 \times S_R$.

include descriptions of the changes or reasons for the changes, or both.

D 3846 – 02:

(J) The precision and bias statement was revised in format in 2001.

ASTM International takes no position respecting the validity of any patent rights asserted in connection with any item mentioned in this standard. Users of this standard are expressly advised that determination of the validity of any such patent rights, and the risk of infringement of such rights, are entirely their own responsibility.

This standard is subject to revision at any time by the responsible technical committee and must be reviewed every five years and if not revised, either reapproved or withdrawn. Your comments are invited either for revision of this standard or for additional standards and should be addressed to ASTM International Headquarters. Your comments will receive careful consideration at a meeting of the responsible technical committee, which you may attend. If you feel that your comments have not received a fair hearing you should make your views known to the ASTM Committee on Standards, at the address shown below.

This standard is copyrighted by ASTM International, 100 Barr Harbor Drive, PO Box C700, West Conshohocken, PA 19428-2959, United States. Individual reprints (single or multiple copies) of this standard may be obtained by contacting ASTM at the above address or at 610-832-9585 (phone), 610-832-9555 (fax), or service@astm.org (e-mail); or through the ASTM website (www.astm.org).