



Designation: D 4476 – 9703

## Standard Test Method for Flexural Properties of Fiber Reinforced Pultruded Plastic Rods<sup>1</sup>

This standard is issued under the fixed designation D 4476; the number immediately following the designation indicates the year of original adoption or, in the case of revision, the year of last revision. A number in parentheses indicates the year of last reapproval. A superscript epsilon ( $\epsilon$ ) indicates an editorial change since the last revision or reapproval.

### 1. Scope\*

1.1 This test method covers the determination of the flexural properties of fiber-reinforced pultruded plastic rods. The specimen is a rod with a semicircular cross section, molded or cut from lengths of pultruded rods (see Fig. 1). This test method is designed for rods with a diameter of  $\frac{1}{2}$  in. or greater.

NOTE 1—There is no ISO equivalent for this standard.

1.2 The values stated in either SI units or inch-pound units are to be regarded separately as standard. The values stated in each system may not be exact equivalents; therefore, each system shall be used independently of the other. Combining values from the two systems may result in nonconformance with the standard.

1.3 *This standard does not purport to address all of the safety concerns, if any, associated with its use. It is the responsibility of the user of this standard to establish appropriate safety and health practices and determine the applicability of regulatory limitations prior to use.*

---

<sup>1</sup> This test method is under the jurisdiction of ASTM Committee D-20 on Plastics and is the direct responsibility of Subcommittee D20.18 on Reinforced Thermosetting Plastics.

Current edition approved Nov. 10, 1997; November 1, 2003. Published April 1998; December 2003. Originally published as D 4476 – 85; approved in 1985. Last previous edition D 4476 – 85 (1990); approved in 1997 as D 4476 - 97.

\*A Summary of Changes section appears at the end of this standard.

**2. Referenced Documents**

2.1 *ASTM Standards:*<sup>2</sup>

- D 618 Practice for Conditioning Plastics and Electrical Insulating Materials for Testing
- D 883 Terminology Relating to Plastics
- D 3918 Definitions of Terms Relating to Reinforced Plastic Pultruded Parts
- E 4 Practices for Load Verification of Testing Machines
- E 691 Practice for Conducting an Interlaboratory Study to Determine the Precision of a Test Method

**3. Terminology**

3.1 For definitions of terms used in this test method, see Terminology D 883 or Definitions D 3918.

**4. Summary of Test Method**

4.1 A rod of semicircular construction is tested in flexure as a simple beam. The specimen rests on two supports and is loaded by means of a loading nose midway between the supports (see Fig. 3).

4.2 The specimen is deflected until rupture occurs in the outer fibers, or until the maximum fiber strain of 5 % is reached, whichever occurs first.

**5. Significance and Use**

5.1 Flexural properties determined by this test method are especially useful for quality control and specification purposes.

5.2 The maximum axial fiber stresses occur on a line under the loading nose. The use of the semicircular cross section eliminates premature compression shear that has been noted in three-point flexure tests on full-round rods.

5.3 Flexural properties may vary with specimen depth, temperature, atmospheric conditions, and differences in rate of straining.

5.4 Before proceeding with this test method, reference should be made to the specification of the material being tested. Any test specimen preparation, conditioning, dimensions, or testing parameters, or combination thereof, covered in the materials specification shall take precedence over those mentioned in this test method. If there are no material specifications, then the default conditions apply.

**6. Apparatus**

6.1 *Testing Machine*—A properly calibrated testing machine that can be operated at constant rates of crosshead motion over the range indicated, and in which the error in the load-measuring system shall not exceed  $\pm 1\%$  of the maximum load expected to be measured. It shall be equipped with a deflection-measuring device. The stiffness of the testing machine shall be such that the total elastic deformation of the system does not exceed 1 % of the total deflection of the test specimen during test, or appropriate corrections shall be made. The load-indicating mechanism shall be essentially free of inertial lag at the crosshead rate used. The accuracy of the testing machine shall be verified in accordance with Practices E 4.

6.2 *Loading Nose and Supports*—The loading nose shall have cylindrical surfaces. In order to avoid excessive indentation or failure due to stress concentration directly under the loading nose, the radius of the nose shall be at least 6.4 mm ( $\frac{1}{4}$  in.) for all specimens. Larger-radius noses are recommended if significant indentation or compressive failure occurs. The curvature of the loading nose in contact with the specimen shall be sufficiently large to prevent contact of the specimen with the sides of the nose. The supports shall consist of anvils to support the round section of the segment (see Fig. 2).

6.3 *Micrometers*—Suitable micrometers for measuring the diameter of the test specimen to an incremental discrimination of at least 0.025 mm ( $\frac{1}{40}$  in.) shall be used.

<sup>2</sup> For referenced ASTM standards, visit the ASTM website, [www.astm.org](http://www.astm.org), or contact ASTM Customer Service at [service@astm.org](mailto:service@astm.org). For Annual Book of ASTM Standards, Vol 08.01, Standards volume information, refer to the standard's Document Summary page on the ASTM website.

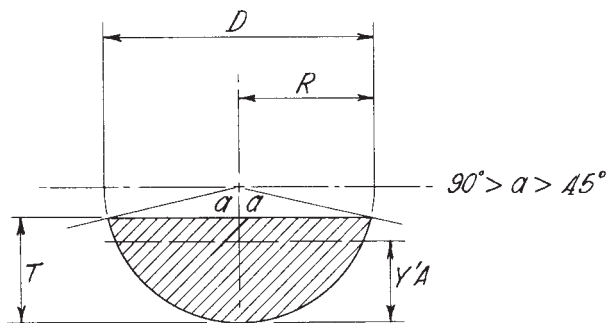

**FIG. 1 Cross Section of Test Specimen**

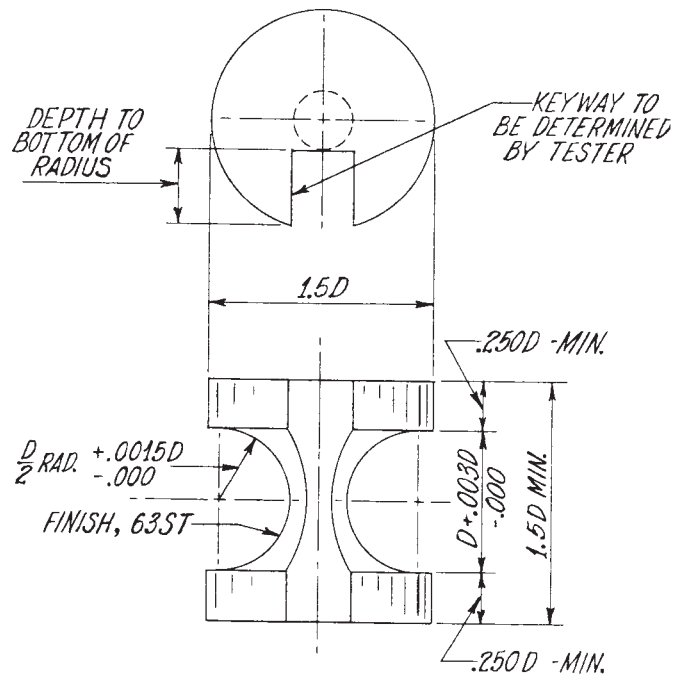

FIG. 2 Arbor Dimensions

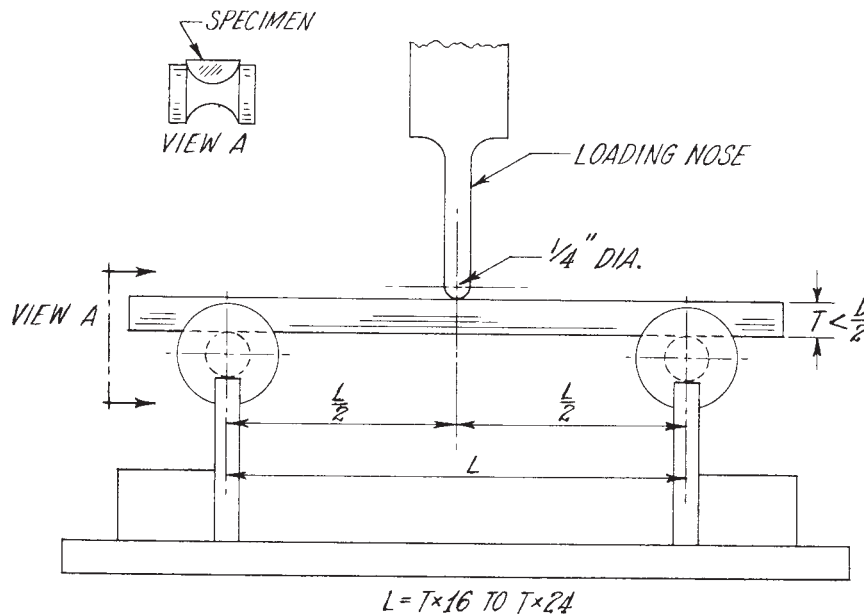

FIG. 3 Schematic of Flexural Test

## 7. Test Specimen

7.1 The test specimen shall consist of a pultruded rod cut into two parts so that the cross section of each part is smaller than a half-round section (see Fig. 1).

7.2 The specimen length shall be 16 to 24 times its thickness or depth, plus at least 20 % of the support span to allow a minimum of 10 % overhang at the supports (see Fig. 3).

NOTE 2—As a general rule, support span-to-depth ratios of 16 to 1 are satisfactory when the ratio of the tensile strength to shear strength is less than 20 to 1, but the support span-to-depth ratio should be increased for composite laminates having relatively low shear strength in the plane of the laminate and relatively high tensile strength parallel to the support span.

7.3 *Number of Specimens*—The number of test specimens is optional. However, a minimum of five specimens is required to obtain a satisfactory average and standard deviation.

## 8. Conditioning

8.1 *Conditioning*—Condition the test specimen at  $23 \pm 2^\circ\text{C}$  ( $[73.4 \pm 3.6^\circ\text{F}]$ ) and  $50 \pm 5\%$  relative humidity for not less than

40 h prior to test in accordance with Procedure A of Practice D 618, for those tests where conditioning is required. In cases of disagreement, the tolerances shall be  $\pm 1^\circ\text{C}$  ( $[\pm 1.8^\circ\text{F}]$ ) and  $\pm 2\%$  relative humidity. These conditions are recommended for research and development trials, but not necessarily for quality control. However, temperature control to  $22.2 \pm 5.6^\circ\text{C}$  ( $[72 \pm 10^\circ\text{F}]$ ) is recommended for quality control.

8.2 *Test Conditions*—Conduct tests in the standard laboratory atmosphere of  $23 \pm 2^\circ\text{C}$  ( $[73.4 \pm 3.6^\circ\text{F}]$ ) and  $50 \pm 5\%$  relative humidity, unless otherwise specified in the test method or in other specifications. In cases of disagreement, the tolerances shall be  $\pm 1^\circ\text{C}$  ( $[\pm 1.8^\circ\text{F}]$ ) and  $\pm 2\%$  relative humidity.

8.3 Preconditioning in other environments to simulate specified conditions and durations is permissible.

8.4 Testing in other environmental conditions is permissible.

## 9. Procedure

9.1 Use an untested specimen for each measurement. Measure the diameter before cutting and depth of the specimen to the nearest  $0.025\text{ mm}$  ( $[0.001\text{ in.}]$ ) at the center of the support span.

9.2 Determine the support span to be used as described in Section 6 and set the support span to within  $1\%$  of the determined value.

9.3 Machine crosshead rate shall be  $3\text{ mm/min}$  ( $[0.1\text{ in./min}]$ ) for samples where  $D/2$  is  $0.25$  to  $0.375\text{ in.}$  and  $6\text{ mm/min}$  ( $[0.2\text{ in./min}]$ ) for samples where  $D/2$  is  $0.375$  to  $0.5\text{ in.}$  The test time should be monitored and the loading rate adjusted. If the test time is less than  $20\text{ s}$ , the loading rate should be reduced. If the test time is greater than  $200\text{ s}$ , the loading rate should be increased.

## 10. Retests

10.1 Values for properties at rupture shall not be calculated for any specimen that breaks at some obvious, fortuitous flaw, unless such flaws constitute a variable being studied. Retests shall be made for any specimen on which values are not calculated.

## 11. Calculation

11.1 *Maximum Fiber Stress*—When a beam of homogeneous, elastic material is tested in flexure as a simple beam supported at two end points and loaded at the midpoint, the maximum fiber stress in the outer fibers occurs at midspan. This stress may be calculated for any point on the load-deflection curve by the following equation (Notes 2 and 3):

$$S = \frac{P \cdot L \cdot C}{4 \cdot I} \quad (1)$$

where:

$S$  = stress in the outer fibers at midspan,  $\text{N/m}^2$  ( $\text{psi}$ ),  $[\text{psi}]$ ,

$P$  = load at a given point on the load-deflection curve,  $\text{N}$  ( $\text{lb}$ ),  $[\text{lb}]$ ,

$L$  = support span,  $\text{m}$  ( $\text{in.}$ ),  $[\text{in.}]$ ,

$I$  = moment of inertia,  $\text{m}^4$  ( $[\text{in.}^4]$ ),

=

$$R^4 \left[ \frac{1}{8} (2G - H) \left( 1 + \frac{2A^3 B}{G - H/2} \right) - \frac{8}{9} \frac{A^4}{(2G - H)} \right]$$

$C$  = distance from centroid to extremities,  $\text{m}$  ( $\text{in.}$ ),  $[\text{in.}]$ ,

=

$$R \left( 1 - \frac{4A^3}{6G - 3H} \right),$$

$R$  =  $D/2$   $\text{m}$  ( $\text{in.}$ ),  $[\text{in.}]$ ,

$A$  =  $\sqrt{\gamma(2 - \gamma)}$ , where  $\gamma = \frac{T}{R}$ ,

$B$  =  $1 - \gamma$ ,

$G$  = arc sine  $A$ , rad,

$H$  =  $2A \cdot B$ ,

$\gamma$  =  $T/R$  – relative thickness of specimen,  $\text{m}$  ( $\text{in.}$ ),  $[\text{in.}]$ ,

$T$  = thickness of specimen,  $\text{m}$  ( $\text{in.}$ ),  $[\text{in.}]$ , and

$D$  = original diameter of specimen,  $\text{m}$  ( $\text{in.}$ ),  $[\text{in.}]$ .

NOTE 3—Eq 1 applies directly to materials for which the stress is linearly proportional to strain up to the point of rupture and for which the strains are small. Since this is not always the case, a slight error will be introduced in the use of this equation. The equation will, however, be valid for comparison data and specification values up to the maximum fiber strain of  $5\%$  for specimens tested by the procedure herein described.

NOTE 4—The preceding calculation is not valid if the specimen is slipping excessively between the supports.

### 11.2 Modulus of Elasticity:

11.2.1 *Tangent Modulus of Elasticity*—The tangent modulus of elasticity, often called the “modulus of elasticity,” is the ratio, within the elastic limit, of stress to corresponding strain, and shall be expressed in newtons per square metre ( $[\text{pounds-force per square inch}]$ ). It is calculated by drawing a tangent to the steepest initial straight-line portion of the load-deflection curve and using Eq 2 as follows:

$$E_b = \frac{P \cdot L^3}{48 \cdot I \cdot Y} \quad (2)$$

where:

- $E_b$  = modulus of elasticity in bending, N/m<sup>2</sup> (psi), [psi],
- $P$  = load at a given point on the load-deflection curve, N (lbf), [lbf],
- $L$  = support span, m (in.), [in.],
- $I$  = moment of inertia, m<sup>4</sup> (in.<sup>4</sup>), [in.<sup>4</sup>],

$$R^4 \left[ \frac{1}{8} (G - H) \left( 1 + \frac{2A^3 B}{G - H/2} \right) - \frac{8}{9} \frac{A^4}{(2G - H)} \right]$$

- $R$  =  $D/2$ , m (in.), [in.],
- $A$  =  $\sqrt{\gamma (2 - \gamma)}$ ,
- $B$  =  $1 - \gamma$ ,
- $G$  = arc sine  $A$ , rad,
- $H$  =  $2A \cdot B$ ,
- $\gamma$  =  $T/R$  – relative thickness of specimen, m (in.), [in.],
- $T$  = thickness of specimen, m (in.), [in.], and
- $D$  = original diameter, m (in.), [in.],

11.3 *Maximum Strain*—The maximum strain in the outer fibers also occurs at midspan, and may be calculated as follows:

$$\epsilon = \frac{12 \cdot C \cdot Y}{L^2} \quad (3)$$

where:

- $\epsilon$  = maximum strain in outer fibers, m/m (in./in.),
- $Y$  = maximum deflection at load chosen, m (in.), [in.],
- $L$  = support span, m (in.), [in.],
- $C$  = distance from centroid to extremities,

$$R \left( 1 - 4 \frac{A^3}{6G - 3H} \right),$$

- $A$  =  $\sqrt{\gamma (2 - \gamma)}$ ,
- $\gamma$  =  $T/R$ ,
- $G$  = arc sine  $A$ , rad,
- $H$  =  $2A \cdot B$ ,
- $B$  =  $1 - \gamma$
- $T$  = thickness of specimen, m (in.), [in.],
- $R$  =  $D/2$ , and
- $D$  = original diameter, m (in.), [in.].

11.4 *Arithmetic Mean*—For each series of tests, the arithmetic mean of all values obtained shall be calculated to three significant figures and reported as the “average value” for the particular property in question.

11.5 *Standard Deviation*—The standard deviation (estimated) shall be calculated as follows and reported in two significant figures:

$$S = \sqrt{\frac{\sum X^2 - n\bar{X}^2}{n - 1}} \quad (4)$$

where:

- $s$  = estimated standard deviation,
- $X$  = value of single observation,
- $n$  = number of observations, and
- $\bar{X}$  = arithmetic mean of the set of observations.

## 12. Report

12.1 Report the following information:

- 12.1.1 Complete identification of the material tested, including type, source, manufacturer’s code number, form, principle dimensions, and previous history,
- 12.1.2 Method of cutting rods,
- 12.1.3 Conditioning procedure,
- 12.1.4 Depth and diameter of specimen,
- 12.1.5 Support span length,

- 12.1.6 Support span-to-depth ratio,
- 12.1.7 Diameters of support and loading noses,
- 12.1.8 Rate of crosshead motion,
- 12.1.9 Flexural strength (if applicable), average value, and standard deviation,
- 12.1.10 Tangent modulus of elasticity in bending, average value, and standard deviation,
- 12.1.11 Stress at any given strain up to and including 5 % (if desired, with strain used, average value, and standard deviation), and
- 12.1.12 Maximum strain in the outer fibers of the specimen (optional).

### 13. Precision and Bias <sup>3</sup>

13.1 Tables 1 and 2 are based on a round robin conducted in 1984, involving three materials tested by eleven laboratories. Each test result was based on five individual determinations. Each laboratory obtained two test results for each material. Tests were conducted at room temperature and 150°F.

NOTE 5—The explanations of  $r$  and  $R$  (13.2-13.2.3) are intended only to present a meaningful way of considering the approximate precision of this test method. The data in Tables 1 and 2 should not be applied to acceptance or rejection of materials, as these data apply only to the materials tested in the round robin and are unlikely to be rigorously representative of other lots, formulations, conditions, materials, or laboratories. Users of this test method should apply the principles outlined in Practice E 691 to generate data specific to their materials and laboratory (or between specific laboratories). The principles of 13.2-13.2.3 would then be valid for such data.

13.2 *Concept of  $r$  and  $R$  in Tables 1 and 2*—If  $S_r$  and  $S_R$  have been calculated from a large enough body of data, and for test results that were averages from testing 5 specimens for each test result, then the following apply:

13.2.1 *Repeatability*—Two test results obtained within one laboratory shall be judged not equivalent if they differ by more than the  $r$  value for that material.  $r$  is the interval representing the critical difference between two test results for the same material, obtained by the same operator using the same equipment on the same day in the same laboratory.

13.2.2 *Reproducibility*—Two test results obtained by different laboratories shall be judged not equivalent if they differ by more than the  $R$  value for that material.  $R$  is the interval representing the critical difference between two test results for the same material, obtained by different operators using different equipment in different laboratories.

13.2.3 Any judgement in accordance with 13.2.1 or 13.2.2 would have an approximate 95 % (0.95) probability of being correct.

13.3 There are no recognized standards by which to estimate bias of this test method.

### 14. Keywords

14.1 flexural properties; plastic rods; pultruded products; thermosetting plastics

## Annual Book of

<sup>3</sup> Supporting data are available at ASTM Standards, Vol 08.02: Headquarters. Request RR: D20-1119.

**TABLE 1 Precision Statement**

Flexural Modulus, 10 <sup>6</sup> , psi		Room Temperature				
Material	Rod Diameter	Mean	$S_r$	$S_R$	$I_r$	$I_R$
Vinyl ester	0.85 in.	7.39	0.365	0.971	1.02	2.75
Vinyl ester	1.00 in.	6.58	0.233	0.850	0.659	2.41
Polyester	1.20 in.	6.38	0.359	0.832	1.02	2.35
Flexural Strength, 10 <sup>3</sup> , psi						
Vinyl ester	0.85 in.	222	5.07	15.9	14.3	44.9
Vinyl ester	1.00 in.	169	2.71	4.78	7.67	13.5
Polyester	1.20 in.	175	3.44	4.05	9.74	11.5

**TABLE 2 Precision Statement**

Flexural Modulus, 10 <sup>6</sup> , psi		150°F				
Material	Rod Diameter	Mean	S <sub>r</sub>	S <sub>R</sub>	I <sub>r</sub>	I <sub>R</sub>
Vinyl ester	0.85 in.	6.87	0.276	1.01	0.781	2.86
Vinyl ester	1.00 in.	6.49	0.167	1.17	0.473	3.31
Polyester	1.20 in.	6.32	0.311	1.05	0.880	2.97
Flexural Strength, 10 <sup>3</sup> , psi						
Vinyl ester	0.85 in.	181	4.81	26.7	13.6	75.6
Vinyl ester	1.00 in.	151	5.92	17.2	16.8	48.7
Polyester	1.20 in.	162	4.13	10.6	11.7	30.0

### SUPPLEMENTARY REQUIREMENTS

Committee D-20 has identified

### SUMMARY OF CHANGES

This section identifies the location of selected changes to this edition test method. For the convenience of this standard since the last issue, user, Committee D20 has highlighted those changes that may impact the use of this test method. This section may also include descriptions of the changes or reasons for the changes, or both.

D 4476 – 03:

(1) Revised paragraph 1.2.

D 4476 – 97:(1) Added

(1) Added ISO equivalency statement to scope. (2) Added

(2) Added terminology section.

(3) Revised calculation section.

(4) Editorial updates of precision and bias and other sections to comply with D-20 editorial directives.

*ASTM International takes no position respecting the validity of any patent rights asserted in connection with any item mentioned in this standard. Users of this standard are expressly advised that determination of the validity of any such patent rights, and the risk of infringement of such rights, are entirely their own responsibility.*

*This standard is subject to revision at any time by the responsible technical committee and must be reviewed every five years and if not revised, either reapproved or withdrawn. Your comments are invited either for revision of this standard or for additional standards and should be addressed to ASTM International Headquarters. Your comments will receive careful consideration at a meeting of the responsible technical committee, which you may attend. If you feel that your comments have not received a fair hearing you should make your views known to the ASTM Committee on Standards, at the address shown below.*

*This standard is copyrighted by ASTM International, 100 Barr Harbor Drive, PO Box C700, West Conshohocken, PA 19428-2959, United States. Individual reprints (single or multiple copies) of this standard may be obtained by contacting ASTM at the above address or at 610-832-9585 (phone), 610-832-9555 (fax), or service@astm.org (e-mail); or through the ASTM website (www.astm.org).*