



Designation: D 5132 – 93 (Reapproved 1994)^{ε1}

Standard Test Method for Horizontal Burning Rate of Flexible Cellular and Rubber Materials Used in Occupant Compartments of Motor Vehicles¹

This standard is issued under the fixed designation D 5132; the number immediately following the designation indicates the year of original adoption or, in the case of revision, the year of last revision. A number in parentheses indicates the year of last reapproval. A superscript epsilon (ϵ) indicates an editorial change since the last revision or reapproval.

^{ε1} NOTE—Section 14, Keywords, was revised editorially in December 1994.

1. Scope

1.1 This test method is intended for use as a small-scale laboratory screening procedure for comparing the relative horizontal burning rates of flexible cellular and rubber materials used in the occupant compartments of motor vehicles.²

1.2 The values stated in SI units are to be regarded as the standard. The values given in parentheses are for information only.

1.3 *This standard should be used to measure and describe the response of materials, products, or assemblies to heat and flame under controlled conditions and should not be used to describe or appraise the fire-hazard or fire-risk of materials, products, or assemblies under actual fire conditions. However, the results of this test may be used as elements of a fire-hazard assessment or a fire-risk assessment which takes into account all of the factors which are pertinent to an assessment of the fire hazard or fire risk of a particular end use.*

1.4 *This standard does not purport to address all of the safety concerns, if any, associated with its use. It is the responsibility of the user of this standard to establish appropriate safety and health practices and determine the applicability of regulatory limitations prior to use.* Specific hazard statements are given in Section 7.

2. Referenced Documents

2.1 ASTM Standards:

D 1349 Practice for Rubber—Standard Temperatures for Testing³

D 3767 Practice for Rubber—Measurement of Dimensions³

D 4483 Practice for Determining Precision for Test Method

¹ This test method is under the jurisdiction of ASTM Committee D-20 on Plastics and is the direct responsibility of Subcommittee D20.30 on Thermal Properties.

Current edition approved Sept. 15, 1993. Published December 1993. Originally published as D 5132 – 90. Last previous edition D 5132 – 90.

² The source document used for the preparation of this test method was United States Department of Transportation Motor Vehicle Safety Standard No. 302. Available from Superintendent of Documents, U.S. Government Printing Office, Washington, DC 20402.

³ *Annual Book of ASTM Standards*, Vol 09.01.

Standards in the Rubber and Carbon Black Industries³

E 176 Terminology Relating to Fire Standards⁴

2.2 *Federal Safety Standard:*

DOTMVSS 302 Flammability of Interior Materials—
Passenger Cars, Multipurpose Passenger Vehicles, Trucks
and Buses⁵

3. Terminology

3.1 *Definitions*—For definitions of fire-related terms used in this test method refer to Terminology E 176.

4. Summary of Test Method

4.1 This test method for measuring the burning rate of materials employs a standard test specimen 100 by 360 by 13 mm (4.0 by 14.0 by 0.5 in.) mounted in a U-shaped metal frame. The specimen is ignited by means of a 38-mm (1.5-in.) high flame from an appropriate burner.

4.2 The rate of burning is reported for each set of specimens as determined by measurements of the horizontal distance burned in relation to the time of burning.

5. Significance and Use

5.1 This test method provides a standard laboratory procedure for measuring and comparing the burning rates of flexible cellular materials and rubber under specified controlled conditions.

5.2 The rate of burning is affected by such factors as density, direction of rise, and type and amount of surface treatments. The thickness of the finished specimens must also be taken into account. These factors must be considered in order to compare materials on the same basis.

5.3 This test method is not intended to be a criterion for fire hazard. Fire hazard evaluation more properly includes other factors, such as flame spread, ease of ignition, fuel contribution, heat evolution, products of combustion, and others.

⁴ *Annual Book of ASTM Standards*, Vol 04.07.

⁵ United States Code of Federal Regulations, 49 CFR 571.302, 36 FR 28991, available from Superintendent of Documents, U.S. Government Printing Office, Washington, DC 20402.

6. Apparatus

6.1 The apparatus shall be as shown in Figs. 1-6 and shall include the following:

6.1.1 *Test Chamber*—A chamber approximately 380 by 355 by 200 mm (15 by 14 by 8 in.) constructed of 1.27-mm (0.050-in.) steel sheet and fabricated in accordance with Fig. 1.

6.1.2 *Burner*—A standard 9.5-mm (0.375-in.) barrel Bunsen or Tirrill burner.

NOTE 1—The burner may be mounted on the door, as shown in Fig. 6, to ensure proper alignment.

6.1.3 *Fuel Supply*—Methane or natural gas having a heating value of 33 to 41 MJ/m³ (900 to 1100 Btu/ft³) regulated to approximately 17 kPa (2.5 psi).

6.1.4 *Specimen Holder Support*—A device capable of maintaining the specimen holder horizontally in place so that the top of the burner tube is positioned 19 mm (0.75 in.) below the top surface of the bottom U-shaped frame when placed in the specimen holder support, as shown in Fig. 2 and Fig. 3. The base of the support shall not obstruct the ventilation holes in the base of the cabinet.

6.1.5 *Specimen Holder*—Two matching U-shaped frames of noncorroding metal stock 25 mm (1.0 in.) wide and 10 mm (0.375 in.) high. The interior dimensions of the U-shaped frames are 50 mm (2 in.) wide by 330 mm (13 in.) long. A specimen that softens and bends at the flaming end so as to cause erratic burning is kept horizontal by supports consisting of thin, heat-resistant wires, spanning the width of the U-shaped frame under the specimen at 25.4-mm (1-in.) intervals. A device that may be used for supporting this type of material is an additional U-shaped frame containing the specimen, spanned by 0.25-mm (0.010-in.) wires of heat-resistant composition at 25 mm intervals inserted over the bottom U-shaped frame. See Fig. 4 and Fig. 5.

6.1.6 *Timing Device*—A timer accurate to the nearest 0.1 s.

6.1.7 *Measuring Device*—A rule accurate to the nearest 1.0 mm as described in Practice D 3767.

7. Hazards

7.1 During the course of combustion, gases or vapors, or both, are evolved that may be hazardous. Adequate precautions should be taken to protect the operator. See 1.4.

8. Test Specimens

8.1 A minimum of five specimens 100 by 355 by a maximum of 13 mm (4.0 by 14.0 by 0.5 in.) are needed. If the sample has a coating or covering that is considered directional in nature, then five specimens should be burned in each direction.

8.2 Cut cellular specimens from uniform density samples. Cut materials supplied in thicknesses greater than 13 mm (0.5 in.) to this thickness. Test materials supplied at less than 13 mm (0.5 in.) at the supplied thickness and record this information as part of the test results.

8.3 Where it is not possible to obtain a flat specimen because of the component configuration, cut the specimen to not more than 12.5 mm (0.5 in.) thickness at any point, from the area with the least curvature, and in such a manner as to include the face side. Use the maximum available length or width of a specimen where either dimension is less than the specified values.

8.4 For composites, laminates, or surface-treated samples, the side nearest to the compartment occupant should be placed facing down during testing.

8.5 If the material's grain pattern or construction is such that it has a directional effect on the burning rate, testing should be conducted in both the transverse and longitudinal directions, as in 8.1. Test five specimens in each direction.

9. Conditioning

9.1 Unless otherwise agreed upon, materials shall be conditioned for 24 h at 23 ± 2°C (73 ± 3.5°F) and 50 ± 5 % relative humidity. Testing shall be conducted under the same conditions. See the Test Temperatures section of Practice D 1349.

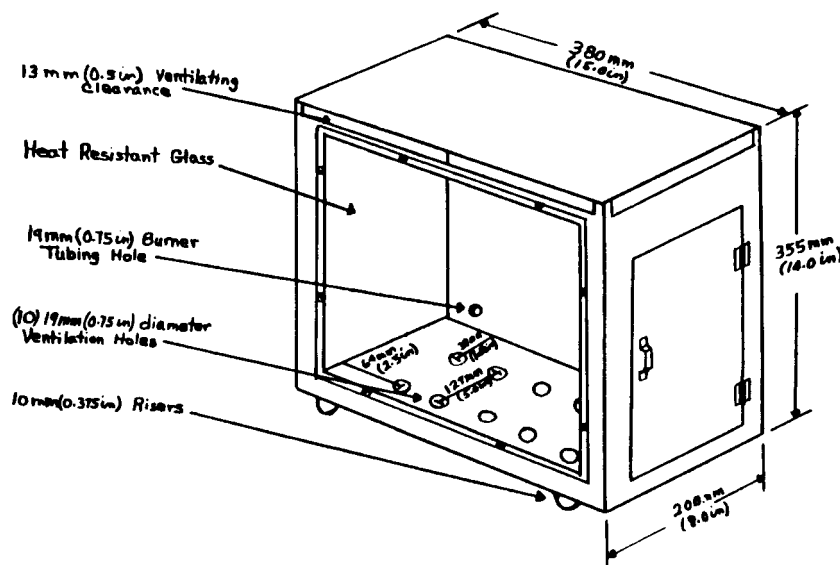

FIG. 1 Horizontal Flammability Chamber

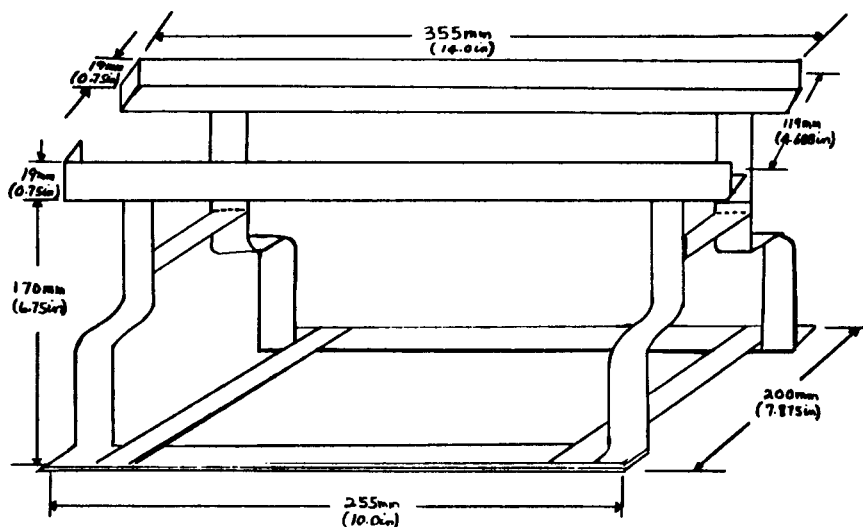

FIG. 2 Typical Specimen Holder Support

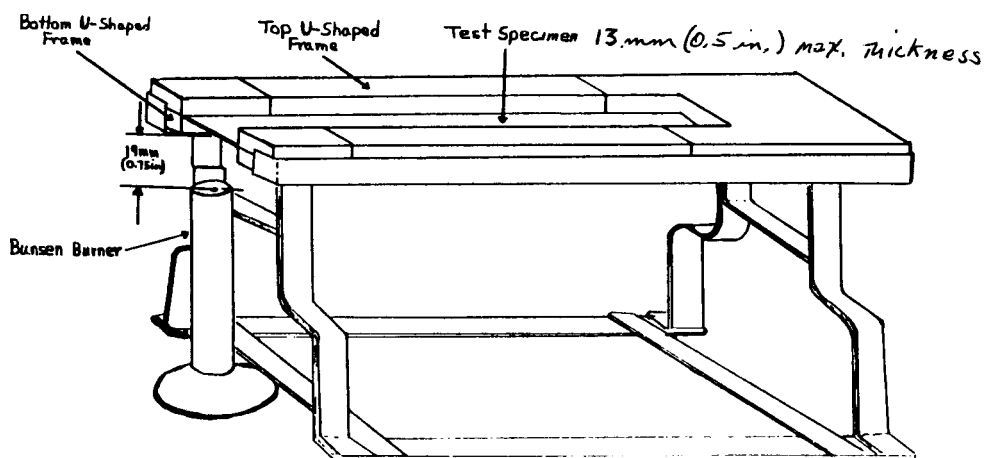
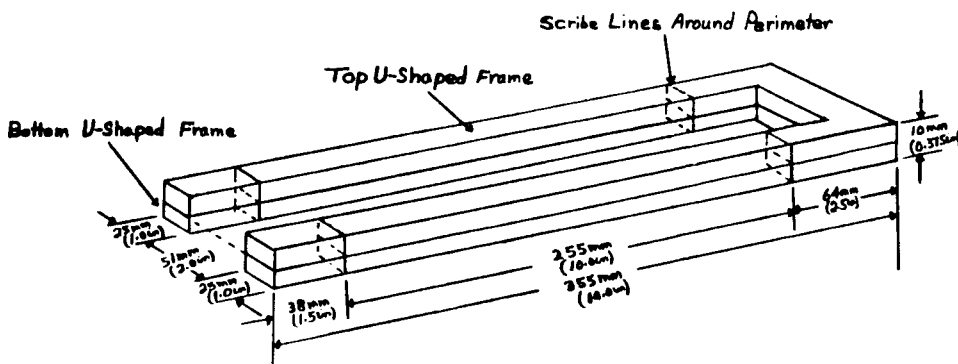

FIG. 3 Specimen Holder With Specimen Positioned in the Specimen Holder Support



Material: Stainless Steel
FIG. 4 Typical Specimen Holder—Two Identical U-Shaped Frames

10. Procedure

10.1 Place the test chamber inside a laboratory exhaust hood.

NOTE 2—The proper control of the hood is necessary to ensure the proper draft. Adjust the baffles or the exhaust motor speed, or both, so that the face velocity conforms to the Class “C” hood requirement of 0.4 m/s (75 ft/min). The effectiveness of the hood may change when the door to the lab is opened and closed.

10.2 Place the test specimen between the two matching U-shaped frames so that both long sides of the specimen and one end are held by the frames.

10.3 With the burner positioned inside the open end of the test chamber and the burner air inlets closed, adjust the gas regulating valve to provide a flame 38 mm (1.5 in.) in height. Position the burner to ensure that the center of the burner top is 19 mm (0.75 in.) below the center of the bottom edge of the

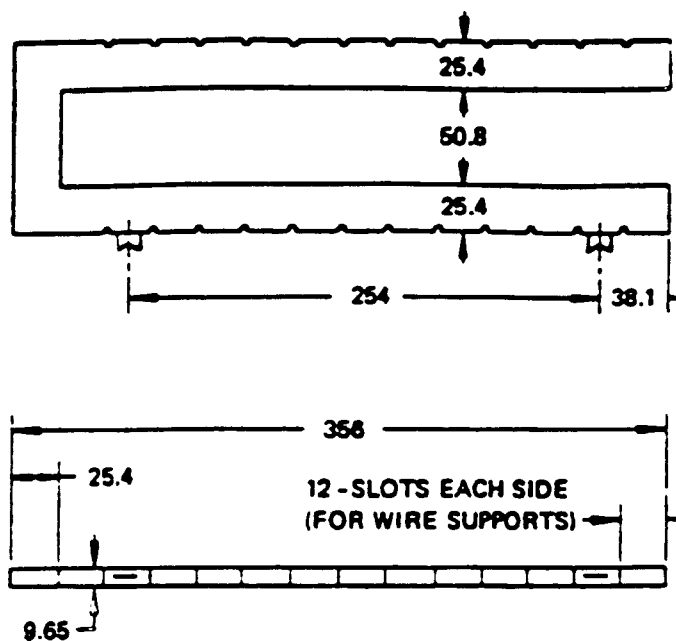

FIG. 5 Bottom U-Frame

specimen at the open end of the specimen holder when the specimen is in the specimen testing position.

10.4 Place the mounted specimen in the horizontal testing position in the specimen holder support inside the test chamber.

10.5 Turn on the exhaust hood.

10.6 Move the flame into contact with the specimen for a period of 15 s, then extinguish the exposure flame.

10.7 Observe the leading edge of the flame front, starting the timer when the scribed mark 38 mm (1.5 in.) from the open end of the sample holder is reached.

10.8 Measure the time it takes the leading edge of the flame front to progress to the line scribed 192 mm (11.5 in.) from the open end of the top or bottom U-shaped frame. If the flame does not reach this specified end point, time its progress to the furthest distance reached.

11. Calculation

11.1 Calculate the burning rate from the following formula:

$$B = d / t \quad (1)$$

where:

B = burning rate, mm/s (in./min),

d = length the flame traveled, mm (in.), and

t = time, s (min) for the flame to travel d mm (in.).

12. Report

12.1 Report the following information:

12.1.1 Average burning rate in millimetres per second (inches per minute) when the flame reaches the specified end point. Report d and t separately for each specimen when the flame extinguishes before reaching the end point. Report "No Measurable Flame Travel" when the flame does not reach the starting point.

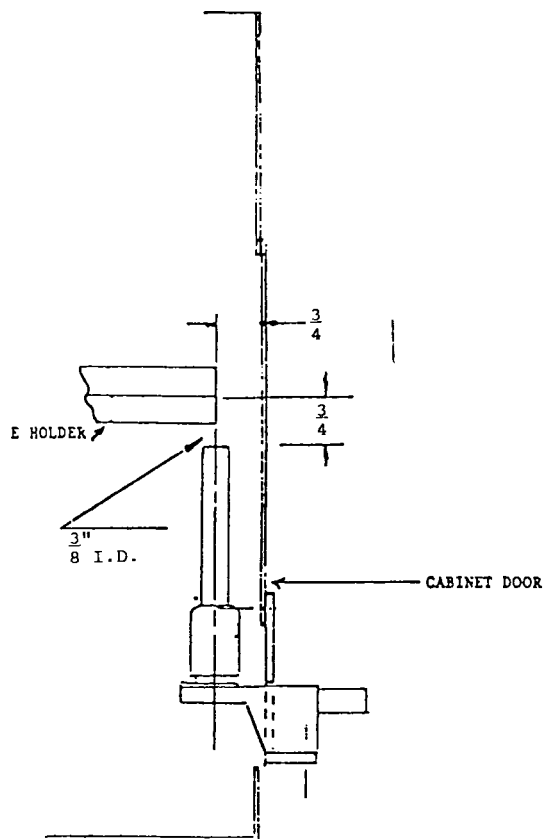

FIG. 6 Burner Position Inside Cabinet

12.1.2 Number of specimens tested.

12.1.3 Thickness and type of specimen tested, that is, composite, laminate, finished section, cellular foam, etc.

12.1.4 Describe observations of burning characteristics such as warping, melting, dripping, charring, etc.

12.1.5 Individual specimen burning rates for materials that demonstrate large specimen to specimen differences.

12.1.6 Directionality of the specimen, if pertinent. See 8.1 and 8.5.

12.1.7 Other information, such as source, lot number, etc. as requested.

12.2 The report shall contain the following statement: "This report is not intended to reflect hazards presented by this or any other material under actual fire conditions."

13. Precision and Bias

13.1 Precision data are not available at this time. Subcommittee D11.17 is investigating the subject and preparing a statement to be determined in accordance with Practice D 4483.

14. Keywords

14.1 burning rate; fire; fire test; flexible cellular materials; horizontal exposure; motor vehicles; rubber

**NOTICE: This standard has either been superceded and replaced by a new version or discontinued.
Contact ASTM International (www.astm.org) for the latest information.**



ASTM International takes no position respecting the validity of any patent rights asserted in connection with any item mentioned in this standard. Users of this standard are expressly advised that determination of the validity of any such patent rights, and the risk of infringement of such rights, are entirely their own responsibility.

This standard is subject to revision at any time by the responsible technical committee and must be reviewed every five years and if not revised, either reapproved or withdrawn. Your comments are invited either for revision of this standard or for additional standards and should be addressed to ASTM International Headquarters. Your comments will receive careful consideration at a meeting of the responsible technical committee, which you may attend. If you feel that your comments have not received a fair hearing you should make your views known to the ASTM Committee on Standards, at the address shown below.

This standard is copyrighted by ASTM International, 100 Barr Harbor Drive, PO Box C700, West Conshohocken, PA 19428-2959, United States. Individual reprints (single or multiple copies) of this standard may be obtained by contacting ASTM at the above address or at 610-832-9585 (phone), 610-832-9555 (fax), or service@astm.org (e-mail); or through the ASTM website (www.astm.org).