



Standard Test Method for Impact Resistance of Flat, Rigid Plastic Specimens by Means of a Falling Dart (Tup or Falling Mass)¹

This standard is issued under the fixed designation D 5628; the number immediately following the designation indicates the year of original adoption or, in the case of revision, the year of last revision. A number in parentheses indicates the year of last reapproval. A superscript epsilon (ϵ) indicates an editorial change since the last revision or reapproval.

1. Scope

1.1 This test method covers the determination of the relative ranking of materials according to the energy required to crack or break flat, rigid plastic specimens under various specified conditions of impact of a free-falling dart (tup).

1.2 The values stated in SI units are to be regarded as the standard. The values in parentheses are for information only.

1.3 *This standard does not purport to address all of the safety concerns, if any, associated with its use. It is the responsibility of the user of this standard to establish appropriate safety and health practices and determine the applicability of regulatory limitations prior to use.* Specific hazard statements are given in Section 8.

NOTE 1—This test method and ISO 6603-1-1985 are technically equivalent only when the test conditions and specimen geometry required for Geometry FE and the Bruceton Staircase method of calculation are used.

2. Referenced Documents

2.1 ASTM Standards:

- D 374 Test Methods for Thickness of Solid Electrical Insulation²
- D 618 Practice for Conditioning Plastics and Electrical Insulating Materials for Testing³
- D 638 Test Method for Tensile Properties of Plastics²
- D 883 Terminology Relating to Plastics²
- D 1600 Terminology for Abbreviated Terms Relating to Plastics²
- D 1709 Test Method for Impact Resistance of Plastic Film by the Free Falling Dart Method²
- D 1898 Practice for Sampling of Plastics²
- D 2188 Practice for Statistical Design in Interlaboratory Testing of Plastics⁴
- D 2444 Test Method for Impact Resistance of Thermoplastic Pipe and Fittings by Means of a Tup (Falling Weight)⁵

¹ This test method is under the jurisdiction of ASTM Committee D-20 on Plastics and is the direct responsibility of Subcommittee D20.10 on Mechanical Properties. Current edition approved March 10, 1996. Published July 1996. Originally published as D 5628 – 94. Last previous edition D 5628 – 95.

² *Annual Book of ASTM Standards*, Vol 08.01.

³ *Annual Book of ASTM Standards*, Vol 10.01.

⁴ Discontinued; see 1982 *Annual Book of ASTM Standards*, Vol 08.02.

⁵ *Annual Book of ASTM Standards*, Vol 08.04.

D 3763 Test Method for High-Speed Puncture Properties of Plastics Using Load and Displacement Sensors⁶

D 4066 Specification for Nylon Injection and Extrusion Materials⁶

E 171 Specification for Standard Atmospheres for Conditioning and Testing Materials⁷

E 177 Practice for Use of the Terms Precision and Bias in ASTM Test Methods⁸

E 691 Practice for Conducting an Interlaboratory Study to Determine the Precision of a Test Method⁸

2.2 ISO Standards:

ISO 291 Standard Atmospheres for Conditioning and Testing⁹

ISO 6603-1 Plastics-Determination of Multiaxial Impact Behavior of Rigid Plastics—Part 1: Falling Dart Method⁹

3. Terminology

3.1 Definitions:

3.1.1 For definitions of plastic terms used in this test method, see Terminologies D 883 and D 1600.

3.2 Definitions of Terms Specific to This Standard:

3.2.1 *failure (of test specimen)*—the presence of any crack or split, created by the impact of the falling tup, that can be seen by the naked eye under normal laboratory lighting conditions.

3.2.2 *mean-failure energy (mean-impact resistance)*—the energy required to produce 50 % failures, equal to the product of the drop height and the mean-failure mass or the product of the constant mass and mean-failure height.

3.2.3 *mean-failure height (impact-failure height)*—the height at which a standard mass when dropped on test specimens, will cause 50 % failures.

NOTE 2—Cracks usually start at the surface opposite the one that is struck. Occasionally incipient cracking in glass-reinforced products, for example, may be difficult to differentiate from the reinforcing fibers. In such cases, a penetrating dye may be used to confirm the onset of crack formation.

3.2.4 *mean-failure mass (impact-failure mass)*—the mass of the dart (tup) that, when dropped on the test specimens from a

⁶ *Annual Book of ASTM Standards*, Vol 08.02.

⁷ *Annual Book of ASTM Standards*, Vol 08.03.

⁸ *Annual Book of ASTM Standards*, Vol 14.02.

⁹ Available from American National Standards Institute, 11 W. 42nd St., 13th Floor, New York, NY 10036.

standard height, will cause 50 % of them to fail.

3.2.5 *tup*—a dart with a hemispherical nose. See 7.2 and Fig. 1.

4. Summary of Test Method

4.1 A free-falling dart (*tup*) is allowed to strike a supported specimen directly. Either a dart having a fixed mass may be dropped from various heights, or a dart having an adjustable mass may be dropped from a fixed height. (See Fig. 2).

4.2 The procedure determines the energy (mass \times height) that will cause 50 % of the specimens tested to fail (mean failure energy).

4.3 The technique used to determine mean failure energy is commonly called the Bruceton Staircase Method or the Up-and-Down Method (1).¹⁰ Testing is concentrated near the mean, reducing the number of specimens required to obtain a reasonably precise estimate of the impact resistance.

4.4 Each test method permits the use of different *tup* and test specimen geometries to obtain different modes of failure, permit easier sampling, or test limited amounts of material. There is no known means for correlating the results of tests made by different methods or procedures.

5. Significance and Use

5.1 Plastics are viscoelastic and therefore may be sensitive to changes in velocity of the mass falling on their surfaces. However, the velocity of a free-falling object is a function of the square root of the drop height. A change of a factor of two in the drop height will cause a change of only 1.4 in velocity. Hagan et al (2) found that the mean-failure energy of sheeting was constant at drop heights between 0.30 and 1.4 m. This suggests that a constant mass-variable height method will give the same results as the constant height-variable mass technique. On the other hand, different materials respond differently to changes in the velocity of impact. Equivalence of these methods should not be taken for granted. While both constant-mass and constant-height techniques are permitted by these methods, the constant-height method should be used for those materials that are found to be rate-sensitive in the range of velocities encountered in falling-weight types of impact tests.

5.2 The test geometry FA causes a moderate level of stress concentration and can be used for most plastics.

5.3 Geometry FB causes a greater stress concentration and results in failure of tough or thick specimens that do not fail with Geometry FA (3). This approach may produce a punch shear failure on thick sheet. If that type of failure is undesirable, Geometry FC may be used. Geometry FB is suitable for research and development because of the smaller test area required.

5.3.1 The conical configuration of the 12.7-mm diameter *tup* used in Geometry FB minimizes problems with *tup* penetration and sticking in failed specimens of some ductile materials.

5.4 The test conditions of Geometry FC are the same as those of Test Method A of Test Method D 1709. They have

been used in specifications for extruded sheeting. A limitation of this geometry is that considerable material is required.

5.5 The test conditions of Geometry FD are the same as for Test Method D 3763.

5.6 The test conditions of Geometry FE are the same as for ISO 6603-1.

5.7 Because of the nature of impact testing, the selection of a test method and *tup* must be somewhat arbitrary. While any one of the *tup* geometries may be selected, knowledge of the final or intended end-use application should be considered.

5.8 Clamping of the test specimen will improve the precision of the data. Therefore, clamping is recommended. However, with rigid specimens, valid determinations can be made without clamping. Unclamped specimens tend to exhibit somewhat greater impact resistance.

6. Interferences

6.1 Falling-mass-impact-test results are dependent on the geometry of both the falling mass and the support. Thus, impact tests should be used only to obtain relative rankings of materials. Impact values cannot be considered absolute unless the geometry of the test equipment and specimen conform to the end-use requirement. Data obtained by different procedures within this test method, or with different geometries, cannot, in general, be compared directly with each other. However, the relative ranking of materials may be expected to be the same between two test methods if the mode of failure and the impact velocities are the same.

6.1.1 Falling-mass-impact types of tests are not suitable for predicting the relative ranking of materials at impact velocities differing greatly from those imposed by these test methods.

6.2 As cracks usually start at the surface opposite the one that is struck, the results can be greatly influenced by the quality of the surface of test specimens. Therefore, the composition of this surface layer, its smoothness or texture, levels of and type of texture, and the degree of orientation introduced during the formation of the specimen (such as may occur during injection molding) are very important variables. Flaws in this surface will also affect results.

6.3 Impact properties of plastic materials can be very sensitive to temperature. This test can be carried out at any reasonable temperature and humidity, thus representing actual use environments. However, this test method is intended primarily for rating materials under specific impact conditions.

7. Apparatus

7.1 *Testing Machine*—The apparatus shall be constructed essentially as is shown in Fig. 2. The apparatus is similar in design to that used in Test Method D 1709 and Test Method D 2444. The geometry of the specimen clamp and *tup* shall conform to the dimensions given in 7.1.1 and 7.2.

7.1.1 *Specimen Clamp*—For flat specimens, a two-piece annular specimen clamp similar to that shown in Fig. 3 is recommended. For Geometries FA and FD, the inside diameter should be 76.0 ± 3.0 mm (3.00 ± 0.12 in.). For Geometry FB, the inside diameter should be 38.1 ± 0.80 mm (1.5 ± 0.03 in.). For Geometry FC, the inside diameter should be 127.0 ± 2.5 mm (5.00 ± 0.10 in.). For Geometry FE an annular specimen clamp similar to that shown in Fig. 4 is required. The inside

¹⁰ The boldface numbers in parentheses refer to a list of references at the end of the text.

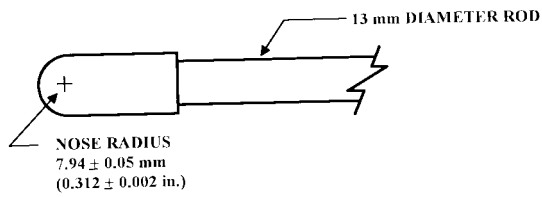

FIG. 1 (a)

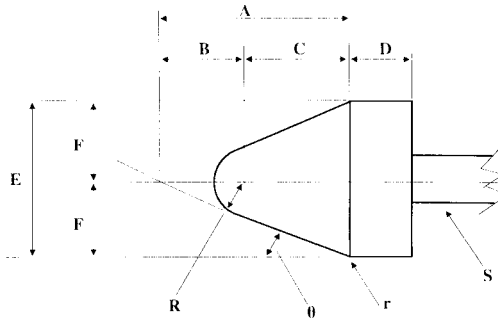

FIG. 1 (b)

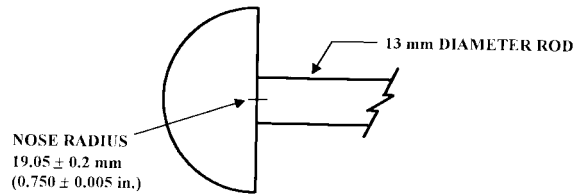

FIG. 1 (c)

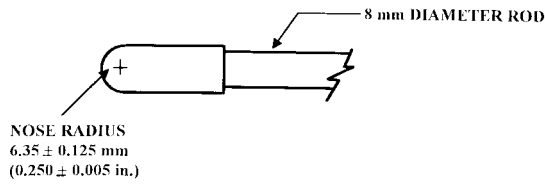

FIG. 1 (d)

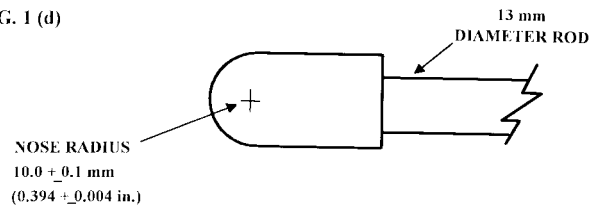

FIG. 1 (e)

Dimensions of Conical Dart—Fig. 1(b)

NOTE 1—Unless specified, the tolerance on all dimensions shall be $\pm 2\%$.

| Position | Dimension, mm | Dimension, in. |
|---------------------------|---------------|----------------|
| A | 27.2 | 1.07 |
| B | 15 | 0.59 |
| C | 12.2 | 0.48 |
| D | 6.4 | 0.25 |
| E | 25.4 | 1 |
| F | 12.7 | 0.5 |
| R | 6.35 ± 0.05 | 0.250 ± 0.002 |
| (nose radius) | | |
| r (radius) | 0.8 | 0.03 |
| S (diameter) ^A | 6.4 | 0.25 |
| θ | 25 ± 1° | 25 ± 1° |

^ALarger diameter shafts may be used.

FIG. 1 Top Geometries for Geometries FA (1a), FB (1b), FC (1c), FD (1d), and FE (1e)

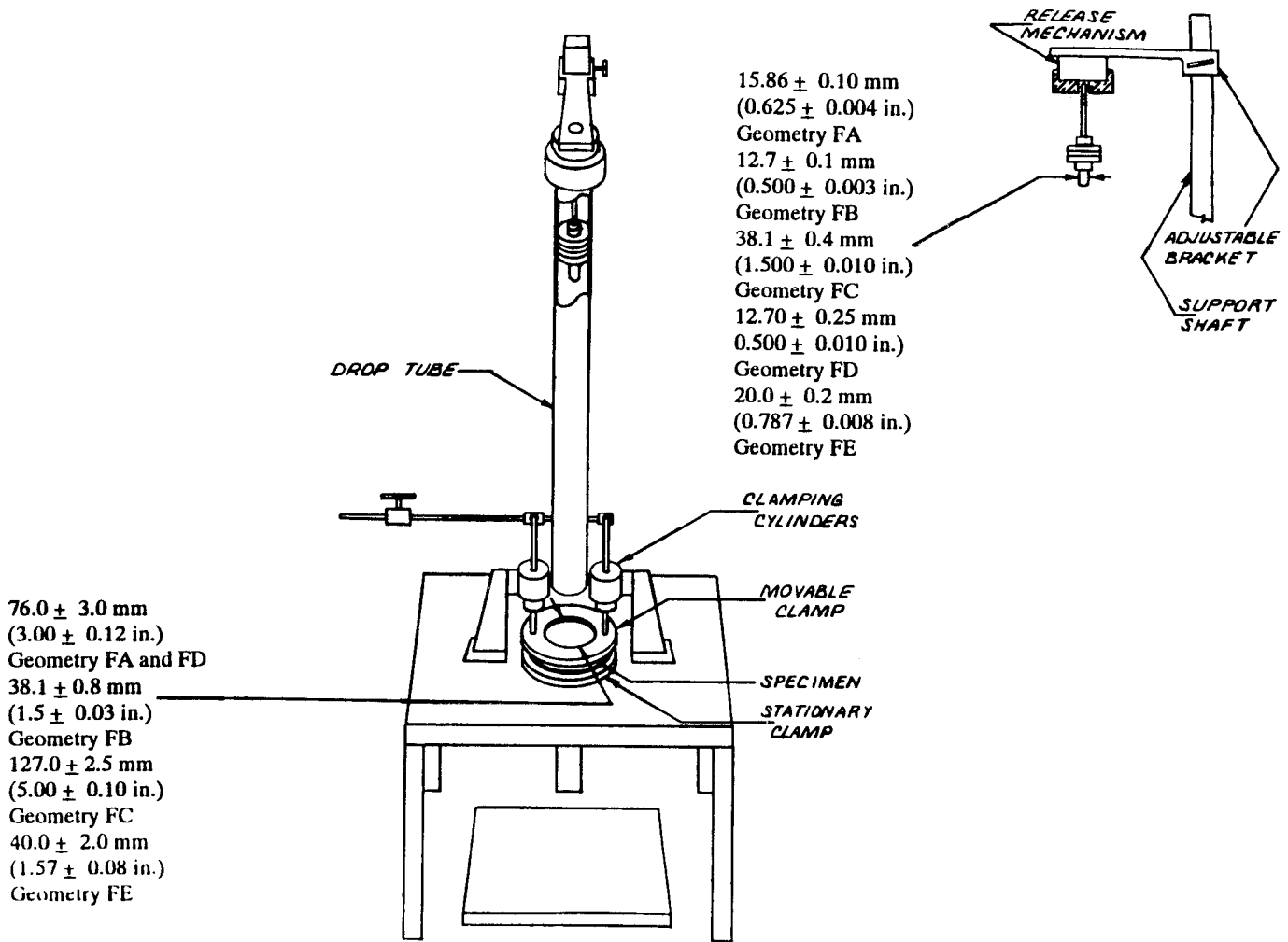

FIG. 2 One Type of Falling Mass Impact Tester

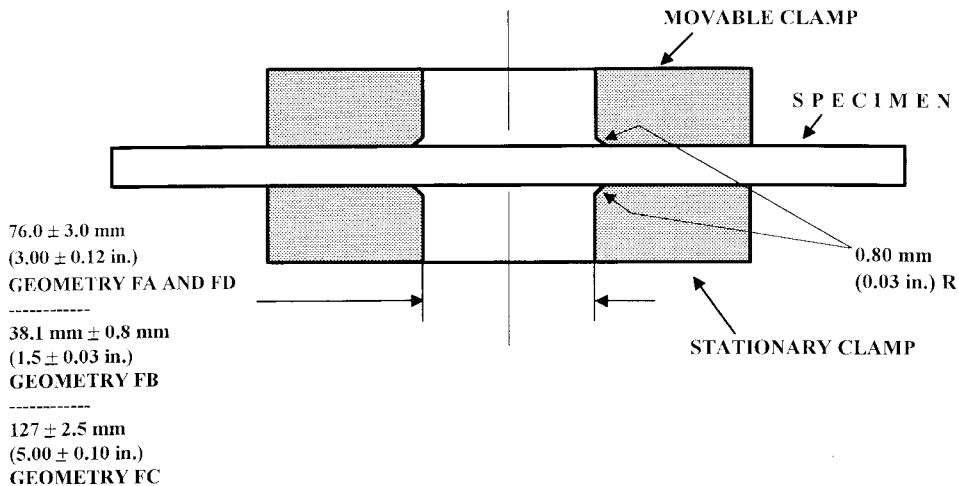

FIG. 3 Support Plate/Specimen/Clamp Configuration for Geometries FA, FB, FC, and FD

diameter should be 40 ± 2 mm (1.57 ± 0.08 in.) (see Table 1). For Geometries FA, FB, FC, and FD, the inside edge of the upper or supporting surface of the lower clamp should be rounded slightly; a radius of 0.8 mm (0.03 in.) has been found to be satisfactory. For Geometry FE this radius should be 1 mm (0.04 in.).

7.1.1.1 Contoured specimens shall be firmly held in a jig so that the point of impact will be the same for each specimen.

7.1.2 *Top Support*, capable of supporting a 13.5-kg (30-lb) mass, with a release mechanism and a centering device to ensure uniform, reproducible drops.

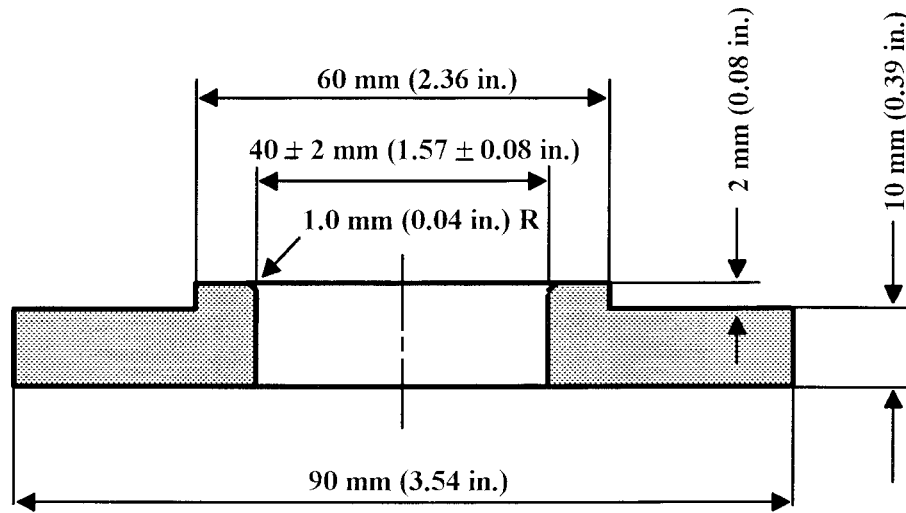

FIG. 4 Test-Specimen Support for Geometry FE

TABLE 1 Tup and Support Ring Dimensions

| Geometry | Dimensions, mm (in.) | |
|----------|---------------------------------|------------------------------|
| | Tup Diameter | Inside Diameter Support Ring |
| FA | 15.86 ± 0.10 (0.625 ± 0.004) | 76.0 ± 3.0 (3.00 ± 0.12) |
| FB | 12.7 ± 0.1 (0.500 ± 0.003) | 38.1 ± 0.8 (1.5 ± 0.03) |
| FC | 38.1 ± 0.4 (1.5 ± 0.010) | 127.0 ± 2.5 (5.00 ± 0.10) |
| FD | 12.70 ± 0.25 (0.500 ± 0.010) | 76.0 ± 3.0 (3.00 ± 0.12) |
| FE | 20.0 ± 0.2 (0.787 ± 0.008) | 40.0 ± 2.0 (1.57 ± 0.08) |

NOTE 3—Reproducible drops may be ensured through the use of a tube or cage within which the tup falls. In this event, care should be exercised so that any friction that develops will not reduce the velocity of the tup appreciably.

7.1.3 *Positioning Device*—Means shall be provided for positioning the tup so that the distance from the impinging surface of the tup head to the test specimen is as specified.

7.2 *Tup*:

7.2.1 The tup used in Geometry FA shall have a 15.86 ± 0.10-mm (0.625 ± 0.004-in.) diameter hemispherical head of tool steel hardened to 54 HRC or harder. A steel shaft about 13 mm (0.5 in.) in diameter shall be attached to the center of the flat surface of the head with its longitudinal axis at 90° to that surface. The length of the shaft shall be great enough to accommodate the maximum mass required (see Fig. 1(a) and Table 1).

7.2.2 The tup used in Geometry FB shall be made of tool steel hardened to 54 HRC or harder. The head shall have a diameter of 12.7 ± 0.1 mm (0.500 ± 0.003 in.) with a conical (50° included angle) configuration such that the conical surface is tangent to the hemispherical nose. A 6.4-mm (0.25-in.) diameter shaft is satisfactory (see Fig. 1(b) and Table 1).

7.2.3 The tup used for Geometry FC shall be made of tool steel hardened to 54 HRC or harder. The hemispherical head shall have a diameter of 38.1 ± 0.4 mm (1.5 ± 0.015 in.). A steel shaft about 13 mm (0.5 in.) in diameter shall be attached to the center of the flat surface of the head with its longitudinal axis at 90° to that surface. The length of the shaft shall be great

enough to accommodate the maximum mass (see Fig. 1(c) and Table 1).

7.2.4 The tup used in Geometry FD shall have a 12.70 ± 0.25-mm (0.500 ± 0.010-in.) diameter hemispherical head of tool steel hardened to 54 HRC or harder. A steel shaft about 8 mm (0.31 in.) in diameter shall be attached to the center of the flat surface of the head with its longitudinal axis at 90° to the surface. The length of the shaft shall be great enough to accommodate the maximum mass required (see Fig. 1(d) and Table 1).

7.2.5 The tup used in Geometry FE shall have a 20.0 ± 0.2-mm (0.787 ± 0.008-in.) diameter hemispherical head of tool steel hardened to 54 HRC or harder. A steel shaft about 13 mm (0.5 in.) in diameter shall be attached to the center of the flat surface of the head with its longitudinal axis at 90° to the surface. The length of the shaft shall be great enough to accommodate the maximum mass required (see Fig. 1(e) and Table 1).

7.2.6 The tup head shall be free of nicks, scratches, or other surface irregularities.

7.3 *Masses*—Cylindrical steel masses are required that have a center hole into which the tup shaft will fit. A variety of masses are needed if different materials or thicknesses are to be tested. For a material of low impact resistance, the tup mass may need to be adjusted by increments of 10 g or less. Materials of high impact resistance may require increments of 1 kg or more.

7.4 *Micrometer*, for measurement of specimen thickness. It should be accurate to 1 % of the average thickness of the specimens used. See Test Methods D 374 for descriptions of suitable micrometers.

7.5 The mass of the tup head and shaft assembly and the additional mass required must be accurate to ±1 %.

8. **Hazards**

8.1 *Safety Precautions*:

8.1.1 Cushioning and shielding devices shall be provided to protect personnel and to avoid damage to the impinging surface of the tup. A tube or cage can contain the tup if it rebounds after striking a specimen.

8.1.2 When heavy weights are used, it is hazardous for an operator to attempt to catch a rebounding tup. Figure 2 of Test Method D 2444 shows an effective mechanical “rebound catcher” employed in conjunction with a drop tube.

9. Sampling

9.1 Unless otherwise agreed upon between the manufacturer and the producer, sample the material in accordance with Sections 9 through 14 of Practice D 1898.

10. Test Specimens

10.1 Flat test specimens shall be large enough so that they can be clamped firmly if clamping is desirable. See Table 2 for the minimum size of specimen that can be used for each test geometry.

10.2 The thickness of any specimen in a sample shall not differ by more than 5 % from the average specimen thickness of that sample. However, if variations greater than 5 % are unavoidable in a sample that is obtained from parts, the sample may be tested, but the data shall not be used for referee purposes. For compliance with ISO 6603-1 the test specimen shall be 60 ± 2 mm (2.4 ± 0.08 in.) in diameter or 60 ± 2 mm (2.4 ± 0.08 in.) square with a thickness of 2 ± 0.1 mm (0.08 ± 0.004 in.). Machining specimens to reduce thickness variation is not permissible.

10.3 When the approximate mean failure mass for a given sample is known, 20 specimens will usually yield sufficiently precise results. If the approximate mean failure mass is unknown, six or more additional specimens should be used to determine the appropriate starting point of the test. For compliance with ISO 6603-1 a minimum of 30 specimens must be tested.

10.4 Carefully examine the specimen visually to ensure that samples are free of cracks or other obvious imperfections or damages, unless these imperfections constitute variables under study. Samples known to be defective should not be tested for specification purposes. Production parts, however, should be tested in the as-received condition to determine conformance to specified standards.

10.5 Select a suitable method for making the specimen that will not affect the impact resistance of the material.

10.6 Specimens may have flat smooth surfaces on both sides, be textured on one side and smooth on the other side, or be textured on both surfaces. Both surfaces may have the same texture or two different levels and types of texture. When testing, special attention must be paid to how the specimen is positioned on the support.

NOTE 4—As few as ten specimens often yield sufficiently reliable estimates of the mean-failure mass. However, in such cases the estimated standard deviation will be relatively large (1).

11. Conditioning

11.1 Unless otherwise specified, condition the test specimens at $23 \pm 2^\circ\text{C}$ ($73.4 \pm 3.6^\circ\text{F}$) and 50 ± 5 % relative humidity for not less than 40 h prior to test, in accordance with Procedure A of Test Methods D 618 and Specification E 171, for those tests where conditioning is required. In cases of disagreement, the tolerances shall be $\pm 1^\circ\text{C}$ ($\pm 1.8^\circ\text{F}$) and ± 2 % relative humidity. For compliance with ISO requirements, the specimens must be conditioned for a minimum of 16 h prior to testing or post conditioning in accordance with ISO 291, unless the period of conditioning is stated in the relevant ISO specification for the material.

11.1.1 Note that for some hygroscopic materials, such as nylons, the material specifications (for example, Specification D 4066) call for testing “dry as-molded specimens”. Such requirements take precedence over the above routine preconditioning to 50 % RH and require sealing the specimens in water vapor-impermeable containers as soon as molded and not removing them until ready for testing.

11.2 Conduct tests in the standard laboratory atmosphere of $23 \pm 2^\circ\text{C}$ ($73.4 \pm 3.6^\circ\text{F}$) and at 50 ± 5 % relative humidity, unless otherwise specified.

11.3 When testing is desired at temperatures other than 23°C , transfer the materials to the desired test temperature within 30 min, preferably immediately, after completion of the preconditioning. Hold the specimens at the test temperature for no more than 5 h prior to test, and, in no case, for less than the time required to ensure thermal equilibrium in accordance with Section 10 of Test Method D 638.

12. Procedure

12.1 Determine the number of specimens for each sample to be tested, as specified in 10.3.

12.2 Mark the specimens and condition as specified in 11.1.

12.3 Prepare the test apparatus for the geometry (FA, FB, FC, FD, FE) selected.

12.4 Measure and record the thickness of each specimen in the area of impact.

12.5 Choose a specimen at random from the sample. A random-numbers table may be used if desired.

12.6 Clamp or position the specimen. The same surface or area should be the target each time (see 6.2). When clamping is employed, the force should be sufficient to prevent motion of the clamped portion of the specimen when the tup strikes.

12.7 Unless otherwise specified, initially position the tup 0.660 ± 0.008 m (26.0 ± 0.3 in.) from the surface of the specimen.

12.8 Adjust the total mass of the tup or the height of the tup, or both, to that amount expected to cause half the specimens to fail.

NOTE 5—If failures cannot be produced with the maximum available missile mass, the drop height can be increased. The test temperature could be reduced by (a) use of an ice-water mixture, or (b) by air-conditioned environment to provide one of the temperatures given in 3.3 of Test Methods D 618. Conversely, if the unloaded tup causes failures when dropped 0.660 m, the drop height can be decreased. A moderate change in

TABLE 2 Minimum Size of Specimen

| Geometry | Specimen Diameter, mm (in.) | Square Specimen, mm (in.) |
|----------|-----------------------------|----------------------------|
| FA | 89 (3.5) | 89 by 89 (3.5 by 3.5) |
| FB | 51 (2.0) | 51 by 51 (2.0 by 2.0) |
| FC | 140 (5.5) | 140 by 140 (5.5 by 5.5) |
| FD | 89 (3.5) | 89 by 89 (3.5 by 3.5) |
| FE | 58 (2.3) | 58 by 58 (2.3 by 2.3) |

dart velocity will not usually affect the mean-failure energy appreciably. Refer to 5.1.

12.9 Release the tup. Be sure that it hits the center of the specimen. If the tup bounces, catch it to prevent multiple impact damage to the specimen's surface (see 8.1.2).

12.10 Remove the specimen and examine it to determine whether or not it has failed. Permanent deformation alone is not considered failure, but note the extent of such deformation (depth, area). For some polymers, for example, glass-reinforced polyester, incipient cracking may be difficult to determine with the naked eye. Exposure of the stressed surface to a penetrating dye, such as gentian violet, may be used to determine the onset of cracking. As a result of the wide range of failure types that may be observed with different materials, the definition of failure defined in the material specification shall take precedence over the definition stated in 3.2.1. Other definitions of failure may be used if agreed upon by supplier and user.

12.11 If the first specimen fails, remove one increment of mass from the tup while keeping the drop height constant, or decrease the drop height while keeping the mass constant (see 12.12). If the first specimen does not fail, add one increment of mass to the tup or increase the drop height one increment, as above. Then test the second specimen.

12.12 In this manner, select the impact height or mass for each test from the results observed with the specimen just previously tested. Test each specimen only once.

12.13 For best results, the mass or height increment used should be approximately equivalent to s , the estimated standard deviation of the test for that sample. An increment of 0.5 to 2 times s is satisfactory (see section 13.4).

NOTE 6—An increment of 10 % of the estimated mean-failure mass of mean-failure height has been found to be acceptable in most instances.

12.14 Keep a running plot of the data, as shown in Appendix X1. Use one symbol, such as X , to indicate a failure and a different symbol, such as O , to indicate a non-failure at each mass or height level.

12.15 For any specimen that gives a break behavior that appears to be an outlier, the conditions of that impact shall be examined. The specimen may be discarded only if a unique cause for the anomaly can be found, such as an internal flaw visible in the broken specimen. Note that break behavior may vary widely within a set of specimens. Data from specimens that show atypical behavior shall not be discarded simply on the basis of such behavior.

13. Calculation

13.1 *Mean-Failure Mass*—If a constant-height procedure was used, calculate the mean-failure mass from the test data obtained, as follows:

$$w = w_o + d_w(A/N \pm 0.5) \quad (1)$$

13.2 *Mean-Failure Height*—If a constant-mass procedure was used, calculate the mean-failure height from the test data obtained, as follows:

$$h = h_o + d_h(A/N \pm 0.5) \quad (2)$$

where:

| | |
|-------|---|
| w | = mean-failure mass, kg, |
| h | = mean-failure height, mm, |
| d_w | = increment of tup weight, kg, |
| d_h | = increment of tup height, mm, |
| N | = total number of failures or non-failures, whichever is smaller. For ease of notation, call whichever are used events, |
| w_o | = smallest mass at which an event occurred, kg |
| h_o | = lowest height at which an event occurred, mm (or in.), |
| A | = $\sum_{i=0}^k in_i$, |
| i | = 0, 1, 2... k (counting index, starts at h_o or w_o), |
| n_i | = number of events that occurred at h_i or w_i , |
| w_i | = $w_o + id_w$, and |
| h_i | = $h_o + id_h$. |

In calculating w or h , the negative sign is used when the events are failures. The positive sign is used when the events are non-failures. Refer to the example in Appendix X1.

13.3 *Mean-Failure Energy*—Compute the mean-failure energy as follows:

where:

MFE = mean-failure energy, J,

MFE = hwf ,

h = mean-failure height or constant height as applicable, mm

w = mean-failure mass or constant mass as applicable, kg, and

f = factor for conversion to joules.

Use $f = 9.80665 \times 10^{-3}$ if $h = \text{mm}$ and $w = \text{kg}$.

13.4 *Estimated Standard Deviation of the Sample*—If desired for record purposes, the estimated standard deviation of the sample for either variable mass or variable height can be calculated as follows:

$$s_w = 1.62d_w[B/N - (A/N)^2] + 0.047d_w \quad (3)$$

$$s_h = 1.62d_h[B/N - (A/N)^2] + 0.047d_h \quad (4)$$

where:

s_w = estimated standard deviation, mass, kg

s_h = estimated standard deviation, height, mm, and

$$B = \sum_{i=0}^k i^2 n_i \quad (5)$$

The above calculation is valid for $[B/N - (A/N)^2] > 0.3$. If the value is < 0.3 , use Table I from Ref (3).

13.5 *Estimated Standard Deviation of the Sample Mean*—Calculate the estimated standard deviation of the sample mean-failure height or weight as follows:

$$S_{\bar{w}} = Gs_w / \sqrt{N} \quad (6)$$

or

$$S_{\bar{h}} = Gs_h / \sqrt{N} \quad (7)$$

where:

$s_{\bar{h}}$ = estimated standard deviation of the mean height, mm,

$s_{\bar{w}}$ = estimated standard deviation of the mean mass, kg, and

G = factor that is a function of s/d (see Appendix X2).

A sample computation of s_w may be found in Appendix X1.

NOTE 7—For values of G at other levels of s/d , see Fig. 22 in Ref ().

13.6 *Estimated Standard Deviation of the Mean-Failure Energy*—Calculate the estimated standard deviation of the mean-failure energy as follows:

$$S_{MFE} = s_{\bar{h}} w f \tag{8}$$

or

$$S_{MFE} = S_w h f, \text{ as applicable} \tag{9}$$

where:

S_{MFE} = estimated standard deviation of the mean-failure energy.

14. Report

14.1 Report the following information:

14.1.1 Complete identification of the sample tested, including type of material, source, manufacturer's code, form, principal dimensions, and previous history,

14.1.2 Method of preparation of specimens,

14.1.3 Whether surface of the specimen is smooth or textured, the level of and type of texture if known, and whether texture is on only one or both surfaces,

14.1.4 If the specimen is textured, report whether textured surface faces upward towards the dart or downward away from the dart,

14.1.5 Means of clamping, if any,

14.1.6 Statement of geometry (FA, FB, FC, FD, FE) and procedure used—constant mass or constant height,

14.1.7 Thickness of specimens tested (average and range).

14.1.8 Number of test specimens employed to determine the mean failure height or mass,

14.1.9 Mean-failure energy,

14.1.10 Types of failure, for example: (a) crack or cracks on one surface only (the plaque could still hold water), (b) cracks that penetrate the entire thickness (water would probably penetrate through the plaque), (c) brittle shatter (the plaque is in several pieces after impact), or (d) ductile failure (the plaque is penetrated by a blunt tear). Report other observed deformation due to impact, whether the specimens fail or not,

14.1.11 If atypical deformation for any specimen within a sample for that material is observed, note the assignable cause, if known,

14.1.12 Date of test and operator's identification,

14.1.13 Test temperature, and

14.1.14 In no case shall results obtained with arbitrary geometries differing from those contained in these test methods be reported as values obtained by this test method (D 5628).

15. Precision and Bias

15.1 Tables 3 and 4 are based on a round robin¹¹ conducted in 1972 involving three materials tested by six laboratories. Data from only four laboratories were used in calculating the values in these tables. Each test result was the mean of multiple individual determinations (Bruceton Staircase Procedure). Each laboratory obtained one test result for a material.

TABLE 3 Precision, Method FB

| Material | Mean, J | Values Expressed as Percent of the Mean | |
|--|-----------|---|------|
| | | V_r | r |
| Polymethyl Methacrylate (PMMA) | 0.35 | 12.6 | 35.7 |
| Styrene-Butadiene (SB) ^A | 9.26 | 18.7 | 52.9 |
| Acrylonitrile-Butadiene-Styrene (ABS) ^A | 11.8 | 14.9 | 42.2 |

^A Data generated in three laboratories.

V_r = within-laboratory coefficient of variation of the mean.

$r = 2.83 V_r$

TABLE 4 Precision, Method FC

| Material | Mean, J | Values Expressed as Percent of the Mean | |
|--------------------------------|-----------|---|------|
| | | V_r | r |
| Polymethyl Methacrylate (PMMA) | 1.33 | 4.13 | 11.7 |
| Styrene-Butadiene (SB) | 48.3 | 18.3 | 51.8 |

V_r = within-laboratory coefficient of variation of the mean.

$r = 2.83 V_r$

NOTE 8—The number of laboratories participating in the 1972 round robin and the number of results collected do not meet the minimum requirements of Practice E 691. Data in Tables 3 and 4 should be used only for guidance, and not as a referee when there is a dispute between users of this test method.

15.1.1 *Polymethylmethacrylate (PMMA)*—Specimens were cut from samples of 3.18-mm (0.125-in.) thickness extruded sheet.

15.1.2 *Styrene-Butadiene (SB)*—Specimens were cut from samples of 2.54-mm (0.100-in.) thickness extruded sheet.

15.1.3 *Acrylonitrile-Butadiene-Styrene (ABS)*—Specimens were cut from samples of 2.64-mm (0.104-in.) thickness extruded sheet.

NOTE 9—**Caution:** The following explanations of r and R (15.2-15.2.3) are only intended to present a meaningful way of considering the approximate precision of this test method. The data in Tables 3 and 4 should not be rigorously applied to acceptance or rejection of material, as those data are specific to the round robin and may not be representative of other lots, conditions, materials, or laboratories. Users of this test method should apply the principles outlined in Practice E 691 to generate data specific to their laboratory and materials, or between specific laboratories. The principles of 15.2-15.2.3 would then be valid for such data.

15.2 *Concept of r and R* —If V_r and V_R have been calculated from a large enough body of data, and for test results that were means from testing multiple individual specimens (Bruceton Staircase Procedure), the following applies:

15.2.1 *Repeatability, r* —In comparing two test results for the same material obtained by the same operator using the same equipment on the same day, the two test results should be judged not equivalent if they differ by more than the r value for that material.

15.2.2 *Reproducibility, R* —In comparing two test results for the same material obtained by different operators using different equipment in different laboratories, reproducibility statistics were not calculated because data from only four and three laboratories do not justify making these calculations.

15.2.3 Any judgment in accordance with 15.2.1 would have an approximate 95 % (0.95) probability of being correct.

15.3 *Bias*—There are no recognized standards by which to estimate bias of this test method.

¹¹ Supporting data are available from ASTM Headquarters. Request RR:D 20-1030.

15.4 Efforts to form a task group to address betweenlaboratory reproducibility of this test method has been unsuccessful. Persons interested in participating in such a task group should contact ASTM Headquarters.

16. Keywords

16.1 dart impact; falling-mass impact; impact; impact resistance; mean-failure energy; mean-failure height; mean-failure mass; rigid plastic; tup

APPENDIX

(Nonmandatory Information)

X1. SAMPLE CALCULATIONS

| Total Dart Mass, kg | Outcome of Test (X = failure; O = non-failure) | | | | | | | | | | | | | | | | | | | | n_x | n_o | i | n_i | in_1 | i^2n_1 |
|---------------------|--|---|---|---|---|---|---|---|---|----|--------|----|---------|---------|----|-------|-------|-------|----|----|-------|-------|-----|-------|--------|----------|
| | 1 | 2 | 3 | 4 | 5 | 6 | 7 | 8 | 9 | 10 | 11 | 12 | 13 | 14 | 15 | 16 | 17 | 18 | 19 | 20 | | | | | | |
| 9.00 | | | | | | X | | | | | | | | | | | | | | | 1 | 0 | 2 | 1 | 2 | 4 |
| 8.00 | | | | | O | | X | | X | | | X | | | X | | | | | | 4 | 1 | 1 | 4 | 4 | 4 |
| 7.00 | | X | | O | | | | O | | X | | O | | O | | X | | X | | O | 4 | 5 | 0 | 4 | 0 | 0 |
| 6.00 | O | | O | | | | | | | | O | | | | | | | O | | O | 0 | 5 | | | | |
| | | | | | | | | | | | Totals | | 9 | 11 | | 9 | 6 | 8 | | | | | | | | |
| | | | | | | | | | | | | | (N_x) | (N_o) | | (N) | (A) | (B) | | | | | | | | |

$$w_o = 7.00; N = N_x = 9; d = 1.00$$

$$w = w_o + d(A/N - 0.5)$$

$$= 7.00 + 1.00 (6/9 - 0.5)$$

$$= 7.17 \text{ kg}$$

$$s = 1.620 d [((NB - A^2)/9^2) + 0.029]$$

$$= 1.620 (1.00) [((9.8 - 6^2)/9^2) + 0.029]$$

$$= 0.77 \text{ kg}$$

$$s/d = 0.77/1.00 = 0.77; G = 1.035 \text{ (from Table X1.1)}$$

$$s_w = Gs/\sqrt{N} = 1.035 (0.77)/\sqrt{9} = 0.27 \text{ kg}$$

TABLE X1.1 Values of G for Obtaining the Estimated Standard Deviation of the Mean

| <i>s/d</i> | 0.00 | 0.01 | 0.02 | 0.03 | 0.04 | 0.05 | 0.06 | 0.07 | 0.08 | 0.09 |
|------------|-------|-------|-------|-------|-------|-------|-------|-------|-------|-------|
| 0.40 | | | | | | 1.18 | 1.175 | 1.17 | 1.16 | 1.155 |
| 0.50 | 1.15 | 1.145 | 1.14 | 1.135 | 1.13 | 1.125 | 1.12 | 1.11 | 1.105 | 1.10 |
| 0.60 | 1.095 | 1.09 | 1.085 | 1.08 | 1.075 | 1.07 | 1.07 | 1.065 | 1.06 | 1.06 |
| 0.70 | 1.055 | 1.055 | 1.05 | 1.05 | 1.045 | 1.04 | 1.04 | 1.035 | 1.035 | 1.03 |
| 0.80 | 1.03 | 1.025 | 1.025 | 1.02 | 1.02 | 1.02 | 1.015 | 1.015 | 1.015 | 1.01 |
| 0.90 | 1.01 | 1.01 | 1.005 | 1.005 | 1.005 | 1.00 | 1.00 | 1.00 | 0.995 | 0.995 |
| 1.00 | 0.995 | 0.99 | 0.99 | 0.99 | 0.985 | 0.985 | 0.985 | 0.985 | 0.98 | 0.98 |
| 1.10 | 0.98 | 0.98 | 0.98 | 0.975 | 0.975 | 0.975 | 0.975 | 0.975 | 0.975 | 0.97 |
| 1.20 | 0.97 | 0.97 | 0.97 | 0.97 | 0.97 | 0.97 | 0.965 | 0.965 | 0.965 | 0.965 |
| 1.30 | 0.965 | 0.965 | 0.965 | 0.965 | 0.96 | 0.96 | 0.96 | 0.96 | 0.96 | 0.96 |
| 1.40 | 0.96 | 0.96 | 0.96 | 0.955 | 0.955 | 0.955 | 0.955 | 0.955 | 0.955 | 0.955 |
| 1.50 | 0.955 | 0.955 | 0.955 | 0.95 | 0.95 | 0.95 | 0.95 | 0.95 | 0.95 | 0.95 |
| 1.60 | 0.95 | 0.95 | 0.95 | 0.95 | 0.945 | 0.945 | 0.945 | 0.945 | 0.945 | 0.945 |
| 1.70 | 0.945 | 0.945 | 0.945 | 0.945 | 0.945 | 0.945 | 0.94 | 0.94 | 0.94 | 0.94 |
| 1.80 | 0.94 | 0.94 | 0.94 | 0.94 | 0.94 | 0.94 | 0.94 | 0.94 | 0.94 | 0.935 |
| 1.90 | 0.935 | 0.935 | 0.935 | 0.935 | 0.935 | 0.935 | 0.935 | 0.935 | 0.935 | 0.935 |
| 2.00 | 0.935 | 0.935 | 0.935 | 0.93 | 0.93 | 0.93 | 0.93 | 0.93 | 0.93 | 0.93 |

REFERENCES

- (1) Brownlee, K. A., Hodgest, J. L., Jr., and Rosenblatt, Murray, "The Up-and-Down Method with Small Samples," *American Statistical Association Journal*, Vol 48, 1953, pp. 262–277.
- (2) Hagan, R. S., Schmitz, J. V., and Davis, D. A., "Impact Testing of High Impact Thermoplastic Sheet," *Technical Papers, 17th Annual Technical Conference of SPE, SPPPB*, Vol VIII, January 1961.
- (3) "Test Method A—Falling Dart Impact, Proposed Method of Test for Impact Resistance of Fabricated Plastics Parts," *Proposed Test Methods for Plastics Parts Used in Appliances*, the Society of the Plastics Industry, New York, NY, January 1965.
- (4) Weaver, O. R., "Using Attributes to Measure a Continuous Variable in Impact Testing Plastic Bottles," *Materials Research and Standards, MR & S*, Vol 6, No. 6, June 1966, pp. 285–291.
- (5) Natrella, M. G., *Experimental Statistics*, National Bureau of Standards Handbook 91, October 1966, pp. 10–22 and 10–23.

The American Society for Testing and Materials takes no position respecting the validity of any patent rights asserted in connection with any item mentioned in this standard. Users of this standard are expressly advised that determination of the validity of any such patent rights, and the risk of infringement of such rights, are entirely their own responsibility.

This standard is subject to revision at any time by the responsible technical committee and must be reviewed every five years and if not revised, either reapproved or withdrawn. Your comments are invited either for revision of this standard or for additional standards and should be addressed to ASTM Headquarters. Your comments will receive careful consideration at a meeting of the responsible technical committee, which you may attend. If you feel that your comments have not received a fair hearing you should make your views known to the ASTM Committee on Standards, 100 Barr Harbor Drive, West Conshohocken, PA 19428.