



Standard Test Methods for Fully Cured Silicone Rubber-Coated Glass Fabric and Tapes for Electrical Insulation¹

This standard is issued under the fixed designation D 1458; the number immediately following the designation indicates the year of original adoption or, in the case of revision, the year of last revision. A number in parentheses indicates the year of last reapproval. A superscript epsilon (ϵ) indicates an editorial change since the last revision or reapproval.

This standard has been approved for use by agencies of the Department of Defense.

1. Scope

1.1 These test methods cover procedures for testing fully cured silicone rubber-coated glass fabric and tapes to be used for electrical insulation.

1.2 The procedures appear in the following order:

Procedure	Sections	ASTM Test Method-References
<u>Procedure</u>	<u>Sections</u>	<u>ASTM References</u>
Breaking Strength	6	D 828
Breaking Strength	7	D 828
Breaking Strength After Creasing	7	...
Breaking Strength After Creasing	8	...
Conditioning	4	...
Conditioning	5	...
Dielectric Breakdown Voltage	8	D 149, D 295, D 618
Dielectric Breakdown Voltage	9	D 149, D 295, D 6054
Dielectric Proof Voltage	9	D 1389
Dielectric Proof Voltage	10	D 1389
Dissipation Factor and Relative Permittivity	10	D 150
Dissipation Factor and Relative Permittivity	11	D 150
Sampling	3	...
Sampling	4	...
Thermal Endurance	14	D 1830
Thermal Endurance	15	D 1830
Thickness	6	D 374
Thickness	6	D 374
Thread Count	13	...
Thread Count	14	...
Volume Resistivity	14	D 257
Volume Resistivity	12	D 257
Weight	12	...
Weight	13	...

1.3 The values stated in inch-pound units are to be regarded as the standard. The values given in parentheses are for information only.

1.4 *This standard does not purport to address all of the safety concerns, if any, associated with its use. It is the responsibility of the user of this standard to establish appropriate safety and health practices and determine the applicability of regulatory limitations prior to use. See 8.9.5.1 for a specific warning statement.*

2. Referenced Documents

2.1 *ASTM Standards:*

¹ These test methods are under the jurisdiction of ASTM Committee D-9 D09 on Electrical and Electronic Insulating Materials and are the direct responsibility of Subcommittee D09.07 on Flexible and Rigid Insulating Materials.

Current edition approved March 10, 1996. 2001. Published May 1996. November 2001. Originally published as D 1458 – 57 T. Last previous edition D 1458 – 946.

- D 149 Test Method for Dielectric Breakdown Voltage and Dielectric Strength of Solid Electrical Insulating Materials at Commercial Power Frequencies²
- D 150 Test Methods for ~~A-C~~ AC Loss Characteristics and Permittivity (Dielectric Constant) of Solid Electrical Insulating Materials²
- D 202 Test Methods for Sampling and Testing Untreated Paper Used for Electrical Insulation²
- D 257 Test Methods for D-C Resistance or Conductance of Insulating Materials²
- D 295 Test Methods for Varnished Cotton Fabrics Used for Electrical Insulation²
- D 374 Test Methods for Thickness of Solid Electrical Insulation²
- ~~D-618 Practice 828 Test Method for Conditioning Plastics~~ Tensile Properties of Paper and Electrical Insulating Materials for Testing Paperboard Using Constant-Rate-of-Elongation Apparatus³
- ~~D-828 Test Method for Tensile Properties of Paper and Paperboard Using Constant-Rate-of-Elongation Apparatus~~⁴
- ~~D-1389 Test 1389~~ Test Method for Proof-Voltage Testing of Thin Solid Electrical Insulating Materials²
- D 1711 Terminology Relating to Electrical Insulation²
- D 1830 Test Method for Thermal Endurance of Flexible Sheet Materials Used for Electrical Insulation by the Curved Electrode Method²
- D 5032 Practice for Maintaining Constant Relative Humidity by Means of Aqueous Glycerin Solutions⁴

² Annual Book of ASTM Standards, Vol 10.01.

³ Annual Book of ASTM Standards, Vol ~~08.04~~, 15.09.

⁴ Annual Book of ASTM Standards, Vol ~~15.09~~, 10.02.

D 6054 Practice for Conditioning Electrical Insulating Materials for Testing⁴
 E 104 Practice for Maintaining Constant Relative Humidity by Means of Aqueous Solutions⁵

3. Terminology

3.1 *Definitions*—For definitions of terms used in these test methods, see Terminology D 1711.

4. Sampling

34.1 Sample shipments of material as specified below, and where possible take only one sample from any package.

34.1.1 *Fabric*—Over 3 in. (75 mm) in width.

34.1.1.1 *Rolls*—Select one roll from each ten rolls or fraction thereof in a shipment of full-width fabric. Cut off not less than two turns of fabric from each roll selected from sampling, and select sample material for the preparation of test specimens from the remaining layers of the roll.

34.1.1.2 *Sheets*—Select one sheet from each 50 sheets or fraction thereof in a shipment of sheeted fabric. Remove not less than six sheets from the outer layers of each package of sheets selected from sampling, and then select sample material for the preparation of test specimens from the remaining sheets.

34.1.2 *Tapes and Strips*—3 in. (75 mm) and less in width.

34.1.2.1 *Tapes*—Cut off not less than six turns of tape from each roll selected for sampling, and then select sample material for the preparation of test specimens from the remaining layers of the roll. Select rolls of tape in accordance with the following schedule:

Number of Rolls in Shipment	Minimum Number of Sample Rolls
Over 10 000	1 per 1000
5001 to 10 000	10
2001 to 5000	5
Less than 2000	2

34.1.2.2 *Strips*—Select three strips from each 100 strips or fraction thereof in a shipment of strips. Remove not less than six strips from the outer layers of each package of strips selected for sampling, and then select sample material for the preparation of test specimens from the remaining strips.

34.2 Prepare the test specimens from samples selected as specified in 34.1, and as provided for in the individual test methods.

45. Conditioning

45.1 *Significance and Use*—The properties of the material described in these test methods are affected by the temperature and moisture content of the material to a greater or lesser extent, depending on the specific property.

45.2 *Conditioning*—Unless otherwise specified in the individual test method, condition test specimens as described in 45.2.1 or 45.2.2, and in matters of dispute, consider 45.2.1 as the referee method.

45.2.1 Condition the test specimens for 48 h in the Standard Laboratory Atmosphere of 50 ± 2 % relative humidity at a temperature of $23 \pm 1^\circ\text{C}$ ($73.4 \pm 1.8^\circ\text{F}$), and conduct the tests under these conditions.

45.2.2 Condition the test specimens for 48 h in the Standard Laboratory Atmosphere of 50 ± 2 % relative humidity at a temperature of $23 \pm 1^\circ\text{C}$ ($73.4 \pm 1.8^\circ\text{F}$), and conduct the tests immediately upon removal of the specimens from the conditioning room or chamber.

56. Thickness

56.1 *Significance and Use:*

56.1.1 The importance of space factor in the design of electrical equipment makes proper determination of thickness essential.

56.1.2 Some properties, such as dielectric strength and dielectric breakdown, vary with the thickness of the material, and certain properties, such as thermal conductivity and dielectric constant, cannot be determined without a knowledge of thickness.

56.2 *Test Specimens*—Cut specimens prepared from fabric samples 1 in. (25 mm) wide across the entire width of the fabric, while specimens prepared from tape and strip samples shall be the width of the sample and 36 in. (910 mm) long. Where the specimen is 36 in. or longer (full-width fabric 36 in. or more in width, or where the length of a strip is 36 in. or longer), only one specimen will be required unless otherwise specified. Where the specimen is less than 36 in. (full-width fabric less than 36 in. wide, or strips less than 36 in. long), as many specimens as are needed to obtain the equivalent 36 in. linear measure will be required.

56.3 *Conditioning*—It is not necessary to condition the specimens for this test. Conduct tests at the Standard Laboratory Temperature of $23 \pm 1^\circ\text{C}$ ($73.4 \pm 1.8^\circ\text{F}$).

56.4 *Procedure*—Make ten measurements, equally spaced along 36 in. (910 mm) of the specimen or specimens in accordance with Method C of Test Methods D 374 modified as follows:

56.4.1 Allow the presser foot to remain on the test specimen for 2 s, at the end of which read the dial gage.

⁵ Annual Book of ASTM Standards, Vol 10.02: 11.03.

56.4.2 Use a presser foot 0.250 in. (6.35 mm) in diameter, and an anvil surface upon which the specimen rests at least 2 in. (51 mm) in diameter. The force exerted on the specimen shall be 3 ozf (85 g).

56.4.3 Method C is not considered interchangeable with Method A.

56.5 *Report*—Report the average, maximum, and minimum thickness to the nearest 0.0001 in. (0.003 mm).

67. Breaking Strength

67.1 *Significance and Use*—The breaking strength of finished fabric or tape is of importance as a measure of the tension it will withstand without failure while being applied in service.

67.2 *Apparatus*—Use a power-driven tensile testing machine meeting the requirements specified for Tensile Properties in Test Methods D 202, except that the means for determining elongation and for recording applied load and elongation are not required. The machine shall be equipped with specimen-gripping devices as described in 67.2.1 or 67.2.2.

67.2.1 Provide two flat-jawed clamps, in which case crocus cloth will be required for holding specimens between the jaws, or

67.2.2 Provide two gripping devices of the drum type as described in Fig. 1, in which case pins as indicated will be required for securing specimens on the cylinders.

67.3 *Test Specimens*—The test specimen shall be of sufficient length to provide positive gripping in the jaws with a separation of approximately 6 in. (150 mm). In the case of the flat-jawed clamps, this will require a minimum specimen length of 8 in. (200 mm) and a desirable length of 10 in. (250 mm). Where drum-type gripping devices are used, a specimen no less than 20 in. (500 mm) long will be required. Prepare the specimens from each sample as follows:

67.3.1 *Fabrics*—Cut five specimens, 1 in. (25.4 mm) wide (Note 1), with sides parallel to the warp threads, and cut five specimens of similar width with sides perpendicular to the warp threads (Note 2).

NOTE 1—Where specimens 1 in. (25.4 mm) in width have ultimate breaking loads exceeding the capacity of the machine, it is permissible to reduce the width of the specimen to not less than 0.5 in. (13 mm).

NOTE 2—Frequently the fill threads of glass fabrics used to manufacture silicone rubber-coated glass fabrics do not run in a straight line and are not perpendicular to the warp threads. Breaking strength from specimens cut perpendicular to the warp threads may, therefore, be highly variable.

67.3.2 *Tapes and Strips*—Cut five specimens, 1 in. (25.4 mm) wide (see Note 2), from each sample. Where tapes or strips are manufactured in widths less than 1 in. (25.4 mm), use the specimen width as manufactured.

67.4 *Conditioning*—It is not necessary to condition specimens for this test. Conduct tests at the Standard Laboratory Temperature of 23 ± 1°C (73.4 ± 1.8°F).

67.5 *Procedure*:

67.5.1 Clamp the ends of the specimen in the jaws between two pieces of crocus cloth, the abrasive side of the cloth facing the metal jaws. Carefully align the specimen so that the breaking force is parallel to the length of the specimen between the jaws. Adjust the clearance between jaws to 6 in. (150 mm).

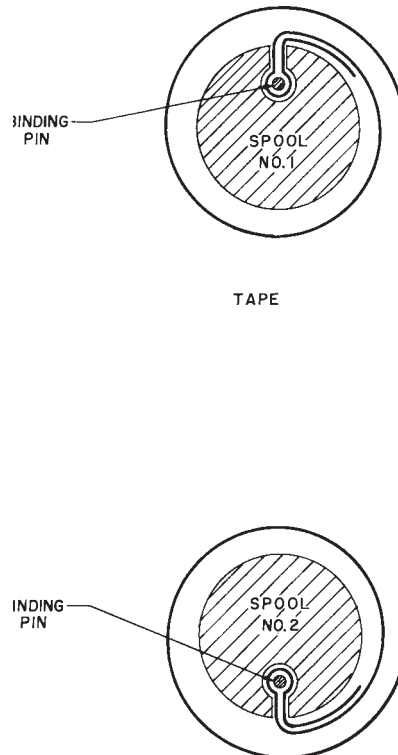

FIG. 1 Drum-Type Gripping Devices

67.5.2 Alternatively, loop the specimen around a binding pin of suitable diameter so that the specimen fits neither too tightly nor too loosely in the hole provided. Insert the looped specimen and pin in the hole provided in the drum-type gripping device. Carefully align the specimen so that the breaking force will be parallel to the length of the specimen. Adjust the clearance between jaws to 6 in. (150 mm).

67.5.3 Adjust the speed of the machine in accordance with the requirements for Tensile Properties in Test Methods D 202.

67.5.4 Disregard values for breaks in or at the jaws. In these cases, continue tests so that there are five reportable breaking strength values per sample.

67.6 *Report:*

67.6.1 Report the average, maximum, and minimum breaking strength in pounds per inch of width (or kilograms per millimetre of width), together with the width and nominal thickness.

67.6.2 In the case of fabrics, report the breaking strength in the warp and fill directions separately.

67.7 *Precision and Bias*—:

7.7.1 The precision (repeatability within a single laboratory) of this test method has been demonstrated to be approximately 17 %, expressed as a coefficient of variation of a series of replicate measurements on different specimens of the same ~~sample~~. ~~Since there is sample.~~

7.7.2 ~~This test method has no-accepted reference material suitable for determining the bias because the value for breaking strength is determined solely in terms of this test-method, no statement on bias is being made.~~

~~7. method itself.~~

8. Breaking Strength After Creasing

78.1 *Significance and Use*—Creasing of silicone rubber-coated glass fabric is accompanied by breaking of some of the glass fibers at the crease and a consequent reduction in breaking strength. The extent of this damage is related to the thickness and weave of the glass fabric and the nature and thickness of the silicone rubber coating. The creasing simulates to a degree the pinching action resulting from several successive layers of tape moving relative to one another while in confined position, such as in cables.

78.2 *Apparatus:*

78.2.1 Use a metal weight adjustable between 2.25 and 4.50 lbf (10 and 20 N). Mount it suitably through guides over a metal horizontal plane so that the weight may be lowered at a uniform speed perpendicular to the horizontal plane. The bottom of the weight shall be parallel to the top surface of the horizontal plane at all times. The creasing surface of the weight is a rectangle of such dimensions that the side which is perpendicular to the crease made on the specimen is 1.5 in. (40 mm). Suitable apparatus is shown in Fig. 2.

78.2.2 Provide suitable means for lowering the weight at a uniform rate of 12 in. (300 mm)/min and of raising the weight at the end of a 2-s dwell. This may be accomplished by utilizing the breaking strength machine, described in ~~6.7.2~~, in combination with a system of pulleys. It may also be achieved by using a motor fitted with reducing gears and a cam, or by other devices that accomplish the purpose.

78.3 *Test Specimens*—Prepare ten specimens as described in ~~6.3.7.3~~ except that specimens shall be taken from samples of tape or rolls of fabric only. In the case of fabric, cut the specimens in the warp direction only.

78.4 *Conditioning:*

78.4.1 It is usually not necessary to condition specimens for this test. When specimens are not especially conditioned, test them at the Standard Laboratory Temperature of $23 \pm 1^\circ\text{C}$ ($73.4 \pm 1.8^\circ\text{F}$).

78.4.2 Where it is desired to obtain the greatest degree of reproducibility, condition specimens in accordance with ~~4.5.2~~.

78.5 *Procedure:*

78.5.1 Adjust the weight so that the specimens are creased by a load of 4.5 lbf (20 N)/in. of width.

78.5.2 Fold the specimen without creasing, and insert the looped end under the weight so that the crease will be formed under the center of the weight. Lower the weight at a uniform rate of 12 in. (300 mm)/min to crease the specimen.

78.5.3 Allow the creased specimen to support the weight for a period of 2 s, at the end of which period lift the weight from the specimen.

78.5.4 Determine the breaking strength of the creased specimen in accordance with ~~6.7.5~~.

78.6 *Report*—Report the following information:

78.6.1 Average, maximum, and minimum breaking strengths after creasing, in kilograms per millimetre of width (or pounds-force per inch of width), unless otherwise specified,

78.6.2 Width and nominal thickness of the specimens, and

78.6.3 Conditioning of specimens.

78.7 *Precision and Bias*—:

8.7.1 The precision (repeatability within a single laboratory) of this test method has been demonstrated to be approximately 8 %, expressed as a coefficient of variation of a series of replicate measurements on different specimens of the same ~~sample~~. ~~Since there is sample.~~

8.7.2 ~~This test method has no-accepted reference material suitable for determining the bias because the value for breaking strength after creasing is determined solely in terms of this test-method, no statement on bias is being made.~~

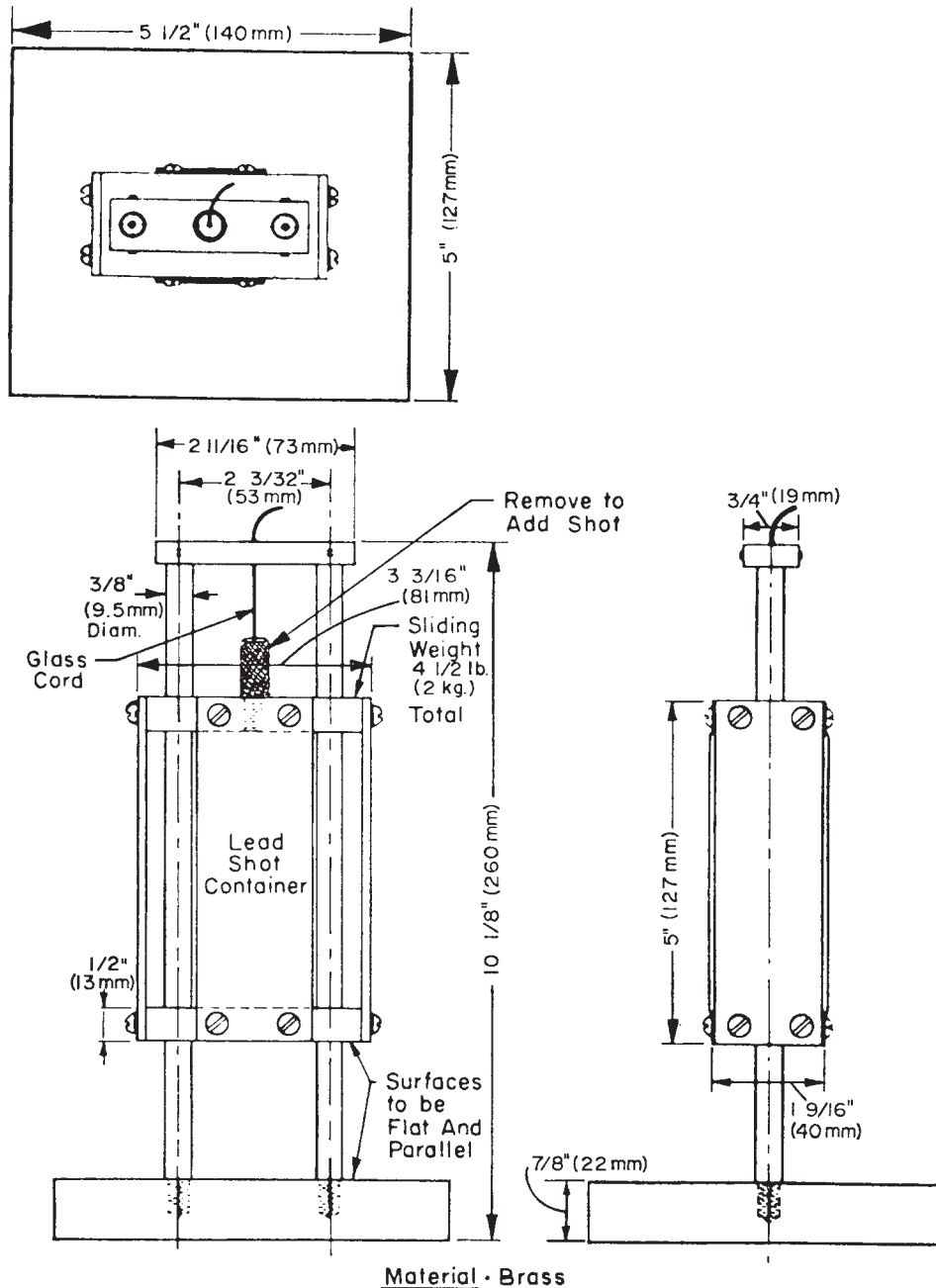

FIG. 2 Creasing Apparatus for Breaking Strength Test

8- method itself.

9. Dielectric Breakdown Voltage

89.1 *Significance and Use:*

89.1.1 Dielectric breakdown voltage of silicone rubber-coated glass fabric and tape indicates the presence of defects in the fabric and tape or in the rubber coating for that part of the surface explored.

89.1.2 Three methods of testing for dielectric breakdown voltage are given: the short-time, step-by-step, and slow-rate-of-rise voltage tests. Choice of the method is based on whether the effect of time under stress is considered an important factor and the available time that can be allowed for each test.

NOTE 3—For a more detailed discussion of the significance of the dielectric breakdown voltage test, consult the general significance statements in Appendix X1 of Test Method D 149.

89.2 *Apparatus:*

89.2.1 *Electrical Apparatus*—Use the apparatus described in Test Method D 149 except as noted in-8 9.2.2.

89.2.2 Electrodes—Cylindrical electrodes, 0.25 in. (6.3 mm) in diameter with edges rounded to 0.03 in. (0.8 mm). Mount them in a test assembly that permits clamping the specimen between pressure gaskets to eliminate voltage flashover as described in Appendix X1 of Test Methods D 295.

89.3 Test Specimens—Use the identical specimens used to measure thickness in ~~5.2~~ 6.2 to determine dielectric breakdown unless they have been damaged. Where separate specimens are specified, prepare these in accordance with ~~5~~ 6.2.

89.4 Conditioning:

89.4.1 Condition test specimens in accordance with ~~4~~ 5.2.

89.4.2 In addition, subject specimens to Condition 24/23/96 as defined in Practice ~~D 618; D 6054~~. After the conditioning period, conduct short-time tests on these specimens without removal from the conditioning chamber. Provide airtight cabinets suitable for maintaining these conditions to prevent condensation of moisture on surfaces within the chamber due to ambient temperature variations and to be in accordance with Practice D 5032 or Practice E 104.

NOTE 4—A cabinet employing saturated potassium sulfate solution and having a ratio of volume of free air to solution surface of 10 in.³/in.² (25 cm³/cm²) and a total volume of about 12 000 in.³ (0.2 m³) has been found to be satisfactory. The use of an aqueous glycerin solution as described in Practice D 5032 has also been found satisfactory.

NOTE 5—Examine electrode supports and gaskets used in this test for susceptibility to corrosion and fungus growth before use. Additional work is now in progress to evaluate the effects of different gasket materials on the breakdown voltage level, although silicone rubber gaskets have been widely used and found to be satisfactory.

89.5 Procedure:

89.5.1 Warning—Lethal voltages may be present during this test. It is essential that the test apparatus, and all associated equipment that may be electrically connected to it, be properly designed and installed for safe operation. Solidly ground all electrically conductive parts that any person might come into contact with during the test. Provide means for use at the completion of any test to ground any parts which: were at high voltage during the test; may have acquired an induced charge during the test; may retain a charge even after disconnection of the voltage source. Thoroughly instruct all operators in the proper way to conduct tests safely. When making high-voltage tests, particularly in compressed gas or in oil, the energy released at breakdown may be sufficient to result in fire, explosion, or rupture of the test chamber. Design test equipment, test chambers, and test specimens so as to minimize the possibility of such occurrences and to eliminate the possibility of personal injury.

89.5.2 For the short-time test method, increase the voltage from zero to breakdown at a uniform rate of 500 V/s.

89.5.3 For the slow-rate-of-rise test method, increase the voltage at a uniform rate of 12.5 V/s for material having a nominal thickness of 0.008 in. (0.2 mm) or less and at a rate of 25 V/s for material having a nominal thickness greater than 0.008 in., starting at a voltage such that the specimen is under test for at least 1 min prior to breakdown.

89.5.4 For the step-by-step test method, each step shall be of 20-s duration. Increase the voltage by an increment of 250 V for materials whose nominal thickness is 0.008 in. (0.2 mm) or less, and by an increment of 500 V for materials whose nominal thickness is greater than 0.008 in. Where feasible, make the starting voltage equal to 50 % of the breakdown voltage obtained in the short-time test and adjusted to the nearest 250 or 500 V, depending on the increment of increase. Otherwise, select the starting voltage as a result of experience, but at such a value that at least three testing steps are obtained prior to breakdown.

89.5.5 Using the short-time method, make ten breakdown tests equally-spaced along 36 in. or 1 m of length on specimens conditioned at 50 % relative humidity and five breakdown tests on each of at least two specimens 1 by 8 in. (25 by 200 mm) conditioned at 96 % relative humidity. Using the step-by-step or the slow-rate-of-rise methods, make five breakdown tests equally spaced 36 in. or 1 m.

89.5.6 Inspect all breakdown punctures. The position of punctures within a circle corresponding approximately to the electrode surface should be random from one test to the other. Where a constant pattern is observed, as where punctures are always in the same relative position, it is very probable that electrode maintenance is required. Disregard the results obtained under this circumstance. Service the electrodes before making further tests.

89.6 Report—Report the following information:

89.6.1 Method used to determine dielectric breakdown,

89.6.2 Average, maximum, and minimum dielectric breakdown in volts for each method,

89.6.3 Average thickness as determined in ~~5~~ 6.2,

89.6.4 Average dielectric strength, where required, obtained by dividing the average breakdown volts as reported in ~~8~~ 9.6.2 by the thickness of ~~8~~ 9.6.3, and

89.6.5 Conditioning of specimens.

89.7 Precision and Bias—:

9.7.1 The precision (repeatability within a single laboratory) of this test method has been demonstrated to be approximately 6 % (conditioned in accordance with ~~4~~ 5.2), and approximately 15 % (conditioned in accordance with ~~8~~ 9.4.2), expressed as a coefficient of variation of a series of replicate measurements on different specimens from the same ~~sample~~. ~~Since there is no accepted reference material suitable for determining the bias for this sample.~~

9.7.2 ~~This test method; has no statement on bias because the value for dielectric breakdown voltage is being made.~~

NOTE 6—Work is now determined solely in progress to develop a suitable terms of this test method for conducting dielectric breakdown tests at elevated temperatures (200°C).

~~9— itself.~~

10. Dielectric Proof-Voltage

~~910.1 Procedure—~~Apply the dielectric proof-voltage in accordance with Test Method D 1389. Adjust the roller speed to ~~7.5~~ 8.5 ± 2.5 ft/min (2.3 ± 0.8 m/min). Unless otherwise specified, adjust the magnitude of the voltage to be one third the dielectric breakdown value found using the short-time method in accordance with ~~8.9.5.4~~ (rounded to the nearest 50 V). In no case, however, use a voltage that is less than 200 V/mil (8 kV/mm) thickness of the material under test.

~~910.2 Precision and Bias—~~No statement is made about either the precision or bias of this test method for dielectric proof-voltage since the result states merely whether there is conformance to the criteria for success specified in the procedure.

101. Dissipation Factor and Relative Permittivity

~~101.1 Significance and Use—~~Statements on the significance of the relative permittivity and dissipation factor are given under Test Methods D 150.

~~101.2 Apparatus—~~Use guarded electrodes, the larger electrode being not over 10 in.² (65 cm²) in area, as described in the following paragraphs. The electrode systems are not considered to be equivalent or interchangeable.

~~101.2.1 Non-contacting electrodes described in the section on Electrode Systems of Test Methods D 150. These electrodes include fixed electrodes, micrometer electrodes and fluid displacement methods.~~

~~101.2.2 Flat rigid electrodes suitably mounted in a specimen holder and capable of applying a pressure not to exceed 10 psi (70 kPa) on the specimen.~~

~~101.2.3 Contacting electrodes described in the section on Electrode Systems of Test Methods D 150. These electrodes include metal foil, conducting paint and evaporated metal.~~

~~101.3 Voltage Stress—~~Unless otherwise specified, make the tests at 60 Hz and under a voltage gradient of not more than 50 V/mil (2 kV/mm).

~~101.4 Test Specimens—~~Test at least three specimens from each sample selected in accordance with ~~3.4.1~~. Take specimens prepared from fabric samples from a strip cut across the entire width of the fabric, and select so as to represent both sides and the center of the fabric, respectively. The specimen shall be of such size that it extends beyond the guard electrode for a distance of at least four times the thickness of the specimen.

~~101.5 Conditioning—~~Condition specimens in accordance with ~~4.5.2~~.

~~101.6 Procedure:~~

~~101.6.1 Make measurements in accordance with the procedures described in Test Methods D 150 except as otherwise specified herein.~~

~~101.6.2 Test conditioned specimens in a single thickness. Where foil electrodes (or other electrodes that are not sufficiently porous to allow free passage of water vapor) are used, apply the electrodes after the conditioning period. Determine the average thickness of each specimen tested in accordance with the procedure of ~~5.6.4~~.~~

~~101.6.3 Determine the average thickness of each specimen tested by the fixed electrode or micrometer electrode system in accordance with the procedure of ~~5.6.4~~.~~

~~101.6.4 Determine the thickness of the specimens tested by using the electrodes described in 101.2.2 at the same pressure as used for the test measurements.~~

~~101.6.5 Determine the thickness of the specimens tested by the contacting electrode systems described in 101.2.3 by averaging the maximum and minimum thicknesses measured by optical means on a cross-section of the material.~~

~~101.7 Report—~~Report the following information:

~~101.7.1 Frequency in hertz,~~

~~101.7.2 Voltage stress in volts per mil,~~

~~101.7.3 Type and size of electrodes,~~

~~101.7.4 Description of bridge,~~

~~101.7.5 Average thickness of each specimen,~~

~~101.7.6 Measured capacitance and dissipation factor of each specimen, and~~

~~101.7.7 Calculated relative permittivity and loss index of each specimen.~~

~~101.8 Precision and Bias—~~The precision of this:

~~11.8.1 This test method has not been determined. Since there is no accepted reference material suitable in use for determining the bias for this test method, many years but no information has been presented to ASTM upon which to base a statement of precision.~~

~~11.8.2 This test method has no bias because the value for dissipation factor and relative permittivity is being made.~~

~~11— determined solely in terms of this test method itself.~~

12. Volume Resistivity

~~112.1 Significance and Use—~~A statement of the significance of volume resistivity is given in Test Methods D 257.

~~112.2 Apparatus—~~Use guarded electrodes, the larger electrode being not over 10 in.² (65 cm²) in area as described in the following paragraphs. The electrode systems are not considered to be equivalent or interchangeable.

112.2.1 Electrodes described in Section 6 of Test Methods D 257, or,
 112.2.2 Flat rigid electrodes suitably mounted in a specimen holder and capable of applying a pressure not to exceed 10 psi (70 kPa) on the specimen.

112.3 *Test Specimens*—Prepare specimens in accordance with the procedure noted in 101.4.

112.4 *Conditioning*—Condition specimens in accordance with 4.5.2.

112.5 *Procedure*:

112.5.1 Make measurements and calculate volume resistivity in accordance with Test Methods D 257, except as otherwise specified below.

112.5.2 Apply 500 V (or other specified voltage) across specimens. Make measurements 1 min after application of voltage.

112.5.3 Test conditioned specimens in a single thickness. Where foil electrodes (or other electrodes that are not sufficiently porous to allow free passage of water vapor) are used, apply electrodes after the conditioning period. Determine the average thickness of each specimen in accordance with the procedure of 5.6.4.

112.6 *Report*—Report the following information:

112.6.1 Voltage stress,

112.6.2 Type and size of electrodes,

112.6.3 Description of instrumentation used,

112.6.4 Average thickness of each specimen, and

112.6.5 Calculated volume resistivity of each specimen.

112.7 *Precision and Bias*—:

12.7.1 The precision of this test method (repeatability within a single laboratory) has been demonstrated to be approximately 33 %, expressed as a coefficient of variation of a series of replicate measurements made on different specimens from the same sample. The precision is approximately 10 %, expressed as a coefficient of variation of a series of measurements on the same specimen at different times, using the same equipment and the same operator. ~~Since there is operator.~~

12.7.2 ~~This test method has no accepted reference material suitable for determining the bias because the value for volume resistivity is determined solely in terms of this test method, no statement on bias is being made.~~

12. method itself.

13. Weight

123.1 *Definition*—The weight of silicone rubber-coated glass fabric and tape is the weight per unit area as determined in accordance with this test method. It is usually expressed in pounds per square yard for a specified nominal thickness.

123.2 *Procedure*—Obtain a specimen of sufficient size to weigh not less than 0.18 ozf (5 g). Determine the weight per unit area using the method given in Test Methods D 295.

123.3 *Precision and Bias*—~~The precision of this:~~

13.3.1 ~~This test method has not been determined. Since there is no accepted reference material suitable in use for determining the bias for this test method, many years, but no information has been presented to ASTM upon which to base a statement of precision. No activity has been planned to develop such information.~~

13.3.2 ~~This test method has no bias because the value for weight is being made.~~

13. determined solely in terms of this test method itself.

14. Thread Count

134.1 *Definition*—The thread count of silicone rubber-coated glass fabric is the number of warp and filling yarns per unit of length or width, counted separately. It is usually expressed in the number of yarns per inch of length or width.

134.2 *Significance and Use*:

134.2.1 Thread count, together with the weight and width of the glass fabric, is accepted as the common means for designating and identifying cloth constructions.

134.2.2 Certain of the physical and electrical properties of woven fabrics are dependent on thread count. That is, assuming the same size of yarn, an increase in thread count increases the weight, breaking strength, and density of the cloth. Also, the dielectric strength and dissipation factor of the silicone rubber-coated fabric may be changed by altering the thread count of the cloth.

134.3 *Procedure*—Count the number of threads for a length of not less than 1 in. (25.4 mm) separately for the warp and fill yarns, making at least five counts in different places on the specimen. Average the five counts in threads per inch to provide an average thread count.

NOTE 76—The warp threads in fabrics are threads that are parallel with the length dimension.

NOTE 87—Before counting opaque materials, it will be necessary to remove the rubber with a knife blade or other suitable instrument.

134.4 *Report*—Report the results of the warp count and the filling count separately as thread count in yarns per inch.

134.5 *Precision and Bias*—~~The precision of this:~~

14.5.1 ~~This test method has not been determined. Since there is no accepted reference material suitable in use for determining the bias for this test method, many years, but no information has been presented to ASTM upon which to base a statement of~~

precision. No activity has been planned to develop such information.

14.5.2 This test method has no bias because the value for thread count is being made:

~~14.~~ **determined solely in terms of this test method itself.**

15. Thermal Endurance

145.1 *Procedure*—Determine the thermal endurance in accordance with Test Method D 1830.

156. Keywords

156.1 a-c breakdown voltage; breaking strength; crease resistance; dissipation factor; permittivity; silicone rubber coated glass fabric; temperature index; thermal endurance; thickness; thread count; volume resistivity; weight (yield)

ASTM International takes no position respecting the validity of any patent rights asserted in connection with any item mentioned in this standard. Users of this standard are expressly advised that determination of the validity of any such patent rights, and the risk of infringement of such rights, are entirely their own responsibility.

This standard is subject to revision at any time by the responsible technical committee and must be reviewed every five years and if not revised, either reapproved or withdrawn. Your comments are invited either for revision of this standard or for additional standards and should be addressed to ASTM International Headquarters. Your comments will receive careful consideration at a meeting of the responsible technical committee, which you may attend. If you feel that your comments have not received a fair hearing you should make your views known to the ASTM Committee on Standards, at the address shown below.

This standard is copyrighted by ASTM International, 100 Barr Harbor Drive, PO Box C700, West Conshohocken, PA 19428-2959, United States. Individual reprints (single or multiple copies) of this standard may be obtained by contacting ASTM at the above address or at 610-832-9585 (phone), 610-832-9555 (fax), or service@astm.org (e-mail); or through the ASTM website (www.astm.org).