



Designation: **D 5568 – 9501**

An American National Standard

Standard Test Method for Measuring Relative Complex Permittivity and Relative Magnetic Permeability of Solid Materials at Microwave Frequencies¹

This standard is issued under the fixed designation D 5568; the number immediately following the designation indicates the year of original adoption or, in the case of revision, the year of last revision. A number in parentheses indicates the year of last reapproval. A superscript epsilon (ϵ) indicates an editorial change since the last revision or reapproval.

1. Scope

1.1 This test method covers a procedure for determining relative complex permittivity (relative dielectric constant and loss index) and relative magnetic permeability of isotropic, reciprocal (nongyromagnetic) solid materials. If the material is nonmagnetic, this procedure may be used to measure permittivity only.

1.2 This measurement method is valid over a frequency range of approximately 1 MHz to 50 GHz. These limits are not exact and depend on the size of the specimen, the size and type of transmission line used as a specimen holder, and on the applicable frequency range of the network analyzer used to make measurements. The lower frequency is limited by the smallest measurable phase shift through a specimen, and the upper frequency limit is determined by the excitation of higher-order modes that invalidates the dominant-mode transmission line model. Any number of discrete measurement frequencies may be selected in this frequency range. To achieve maximum measurement accuracy, use of different transmission line sizes and types may be required. For example, use of a 7-mm diameter coaxial geometry can provide for measurements from 1 MHz to 18 GHz. However, air gaps

¹ This test method is under the jurisdiction of ASTM Committee ~~D-9~~ D09 on Electrical and Electronic Insulating Materials and is the direct responsibility of Subcommittee D09.12 on Electrical Tests.

Current edition approved ~~July 15, 1995~~; Mar. 10, 2001. Published ~~October 1995~~; May 2001. Originally published as D 5568 – 94. Last previous edition D 5568 – 94⁵.

that exist between the specimen and the transmission line's conductors introduce errors² that may necessitate the use of a larger diameter coaxial transmission line and a series of rectangular wave guides of different size to cover this frequency range.

1.3 The values stated in SI units are to be regarded as the standard. The values given in parentheses are for information only.

1.4 *This standard does not purport to address all of the safety concerns, if any, associated with its use. It is the responsibility of the user of this standard to establish appropriate safety and health practices and determine the applicability of regulatory limitations prior to use.*

2. Referenced Documents

2.1 *ASTM Standards:*

D 1711 Terminology Relating to Electrical Insulation³

3. Terminology

3.1 For other definitions used in this test method, refer to Terminology D 1711.

3.2 *Definitions:*

3.2.1 *relative complex permittivity (relative complex dielectric constant) (relative complex capacitance), ϵ_R , n* —the ratio of the admittance of a given configuration of the material to the admittance of the same configuration with vacuum as dielectric:

$$\epsilon_R^* = \frac{Y}{Y_0} = \frac{Y}{j\omega C'v} = \epsilon'_R - j\epsilon''_R \quad (1)$$

where Y is the admittance with the material and $j\omega C'v$ is the admittance with vacuum.

3.2.1.1 *Discussion*—In common usage the word “relative” is frequently dropped. The real part of complex relative permittivity (ϵ'_R) is often referred to as simply relative permittivity, permittivity or dielectric constant. The imaginary part of complex relative permittivity (ϵ''_R) is often referred to as the loss index. In anisotropic media, permittivity is described by a three dimensional tensor.

3.2.2 For the purposes of this test method, the media is considered to be isotropic, and therefore permittivity is a single complex number.

3.3 *Definitions of Terms Specific to This Standard:*

3.3.1 A list of symbols specific to this test method is given in Annex A1.

3.3.2 *calibration, n* —a procedure for connecting characterized standard devices to the test ports of a network analyzer to characterize the measurement system's systematic errors. The effects of the systematic errors are then mathematically removed from the indicated measurements. The calibration also establishes the mathematical reference plane for the measurement test ports.

3.3.2.1 *Discussion*—Modern network analyzers have this capability built in. There are a variety of calibration kits that can be used depending on the type of test port. The models used to predict the measurement response of the calibration devices depends on the type of calibration kit. Most calibration kits come with a tape or disc that can be used to load the definitions of the calibration devices into the network analyzer. Calibration kit definitions loaded into the network analyzer must match the devices used to calibrate. Since both transmission and reflection measurements are used in this standard, a two-port calibration is required.

3.3.3 *network analyzer, n* —a system that measures the two-port transmission and one-port reflection characteristics of a multiport system in its linear range and at a common input and output frequency.

3.3.3.1 *Discussion*—For the purposes of this standard, this description includes only those systems that have a synthesized signal generator, and that measure both magnitude and phase in the forward and reverse directions of a two-port network (S_{11} , S_{21} , S_{12} , S_{22}).

3.3.4 *relative complex permeability, μ_R^* , n* —a term used to express the relationship between magnetic induction and magnetizing force defined by the ratio of the absolute permeability to the magnetic constant, given by

$$\mu_R^* = \mu'_R - j\mu''_R = \frac{|\vec{B}|}{\mu_0 |\vec{H}|} \quad (2)$$

where μ_0 is the permeability of free space.

3.3.5 *Discussion*—In common usage the word “relative” is frequently dropped. The real part of complex relative permeability (μ'_R) is often referred to as relative permeability or permeability. The imaginary part of complex relative permeability (μ''_R) is often referred to as the magnetic loss index. In anisotropic media, permeability is described by a three dimensional tensor.

3.3.5.1 For the purposes of this test method, the media is considered to be isotropic, and therefore permeability is a single complex number.

3.3.6 *scattering parameter (S-parameter), S_{ij} , n* —a complex number consisting of either the reflection or transmission coefficient of a component at a specified set of input and output reference planes with all other planes terminated by a non-reflecting termination.

3.3.7 *Discussion*—As most commonly used, these coefficients represent the quotient of the complex electric field strength (or voltage) of a reflected or transmitted wave divided by that of an incident wave. The subscripts i and j of a typical coefficient S_{ij}

² ASTM STP 926 “Engineering Dielectrics, Volume 11B, Electrical Properties of Solid Insulating Materials: Measurement Techniques,” 1987.

³ *Annual Book of ASTM Standards*, Vol 10.01.

refer to the output and input ports, respectively. For example, the forward transmission coefficient S_{21} is the ratio of the transmitted wave voltage at Reference Plane 2 (Port 2) divided by the incident wave voltage measured at Reference Plane 1 (Port 1). Similarly, the Port 1 reflection coefficient S_{11} is the ratio of the Port 1 reflected wave voltage divided by the Port 1 incident wave voltage.

3.3.8 *transverse electric (TE_{mn}) wave, n* —an electromagnetic wave in which the electric field is everywhere perpendicular to the direction of propagation.

3.3.8.1 *Discussion*—The index m is the number of half-period variations of the field along the wave guide’s larger transverse dimension, and n is the number of half-period variations of the field along the wave guide’s smaller transverse dimension. The dominant wave in a rectangular wave guide is TE_{10} . The electric field lines of the TE_{10} mode are parallel to the shorter side.

3.3.9 *transverse electromagnetic (TEM) wave, n* —an electromagnetic wave in which both the electric and magnetic fields are perpendicular to the direction of propagation.

3.3.9.1 *Discussion*—In coaxial transmission lines the dominant wave is TEM.

4. Summary of Test Method

4.1 A carefully machined test specimen is placed in an electromagnetic transmission line and connected to a calibrated network analyzer that is used to measure the S -parameters of the transmission line-with-specimen. A specified data-reduction algorithm is then used to calculate permittivity and permeability. If the material is nonmagnetic a different algorithm is used to calculate permittivity only. Error corrections are then applied to compensate for the existence of air gaps between the specimen and the transmission line’s conductors.

5. Significance and Use

5.1 Design calculations for Radio Frequency (RF), microwave and millimeter-wave components require the knowledge of values of complex permittivity and permeability at operating frequencies. This test method is useful for evaluating batch type or continuous production of material for use in electromagnetic applications. It may be used to determine complex permittivity only or both complex permittivity and permeability simultaneously.

6. Interferences

6.1 The upper limits of permittivity and permeability that can be measured using this test method are restricted by the transmission line and specimen geometries. No specific limits are given in this standard, but this test method is practically limited to low-to-medium values of permittivity and permeability. In 7-mm coaxial lines, specimen permittivities <30 and permeabilities <100 can be determined if the air gap between the specimen and the inner and outer conductors is known. Rectangular wave guides yield higher limits, and in general these upper limits increase as transmission line cross-sectional area increases.

6.2 The existence of air gaps between the test specimen and the transmission line introduces a negative bias into measurements of permittivity and permeability. In this test method compensation for this bias is required, and to do so requires knowledge of the air gap sizes. Air gap sizes are estimated from dimensional measurements of the specimen and the specimen holder. Several different error correction models have been developed, and a frequency independent series capacitor model is described in Annex A2.

7. Apparatus

7.1 *Experimental Setup* is given in Fig. 1 as a block diagram.

7.2 *Network Analyzer*—The network analyzer needs a full 2-port test set that can measure scattering parameters in both directions. Use a network analyzer that has a synthesized signal generator in order to ensure good frequency stability and signal purity. To define the Port 1 and Port 2 Reference Planes with respect to magnitude and phase, perform a two-port calibration of the network analyzer.

7.3 *Computer*—Use a computer for network analyzer data acquisition and computation of permittivity and permeability from the measured scattering parameters. Any computer capable of these functions is sufficient for the purposes of this test method.

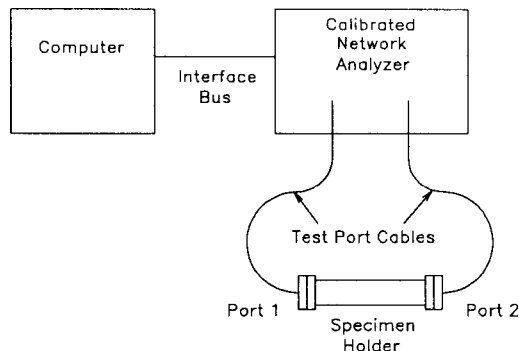

FIG. 1 Block Diagram of Experimental Setup

7.4 *Network Analyzer Calibration Kit*—To define Port 1 and Port 2 Measurement Reference Planes, calibration of the network analyzer is required. A network analyzer calibration kit consists of well characterized standard devices and mathematical models of those devices. A through-reflect-line (TRL), open-short-load-through (OSLT), or other calibration kit that yields similar calibration quality may be used to calibrate the network analyzer.

7.5 *Specimen Holder:*

7.5.1 Because parameters such as specimen holder length and cross-sectional dimensions are of critical importance to the calculation of permittivity and permeability, carefully measure and characterize the physical dimensions of the specimen holder.

7.5.2 Although not required, it is helpful if the specimen is nearly the same length as the specimen holder. This minimizes conductor losses that cause a positive bias to ϵ''_R results. If desired, use measurement techniques to remove conductor losses. Two possible procedures to remove specimen holder conductor losses are outlined in Appendix X2.

7.5.3 Either rectangular wave guides or beadless coaxial lines may be used as the specimen holder. Coaxial lines consist of two concentric cylindrical conductors that guide TEM waves. Coaxial lines have an advantage over rectangular wave guides in that they can be used to perform very broadband measurements. Coaxial lines have no lower cutoff frequency, and therefore can be used for measurements at relatively low frequencies. The upper frequency limit of a coaxial line is limited by overmoding, determined by the diameters of the outer and inner conductors. As these diameters become larger, the cutoff frequencies of higher-order modes become lower. The theoretical model used for this test method assumes that only the dominant mode of propagation exists (TEM for coaxial lines, TE_{10} for rectangular wave guides). The existence of higher-order modes limits the applicability of the model. Use of rectangular wave guide has two distinct advantages over coaxial line: (1) test specimen is easier to machine, and (2) for a given gap size, air gap corrections are smaller for rectangular wave guides than for coaxial lines.

7.5.4 Be sure that the specimen holder dimensions are within proper tolerances for the transmission line size in use. If a 7-mm coaxial transmission line is used, let L_1 , D_1 , L_2 , and D_2 be the length and diameter of the inner conductor and the length and diameter of the outer conductor, respectively. Proper tolerances are then:

center conductor: (3)

$$D_1 = 3.040 \pm 0.005 \text{ mm } (0.1197 \pm 0.0002 \text{ in.}),$$

outer conductor: (4)

$$D_2 = 7.000 \pm 0.006 \text{ mm } (0.2756 \pm 0.00025 \text{ in.}), \text{ and}$$

$$L_2 \geq L_1 > L_2 - 0.00102 \text{ mm } (L_2 \geq L_1 > L_2 - 0.0004 \text{ in.}). \tag{5}$$

Dimensions and tolerances of other coaxial sizes are in the appropriate manufacturer’s specifications. Dimensions and tolerances of standard rectangular wave guides are in various references.⁴

8. Test Specimen

8.1 Make the test specimen long enough to ensure good alignment inside the holder. Also, make the test specimen long enough to ensure that the phase shift through the specimen is much greater than the phase measurement uncertainty of the network analyzer at the lowest measurement frequency.

8.2 Accurately machine the specimen so that its dimensions minimize the air gap that exists between the conductor(s) and the specimen. In this respect, measure the specimen holder’s dimensions in order to specify the tightest tolerances possible for specimen preparation. A test specimen that fits into coaxial transmission lines is a toroidal cylinder. Typical dimensional specifications for a 7-mm coaxial test specimen are given in Fig. 2. A test specimen for rectangular wave guides has rectangular shape. Fig. 3 gives dimensional specifications for a specimen that fits into X-band (8.2 to 12.4 GHz) wave guide. The given dimensional specifications provide nominal tolerances only. Keep physical variations of specimen dimensions as small as is practicable. Include specimen dimensions and uncertainties in the report.

9. Preparation of Apparatus

9.1 *Inspect Network Analyzer Test Ports*—Insure that the recession of both test ports’ center conductor shoulder behind the outer conductor mating plane meets the minimum specifications. For a 7-mm connector, the recession is 0.005 to 0.021 mm (0.0002 to 0.008 in.) with the collet removed.

⁴ Johnson, C. J., and Jasik, H., eds., *Antenna Engineering Handbook*, McGraw-Hill Book Company, New York, NY, 1984.

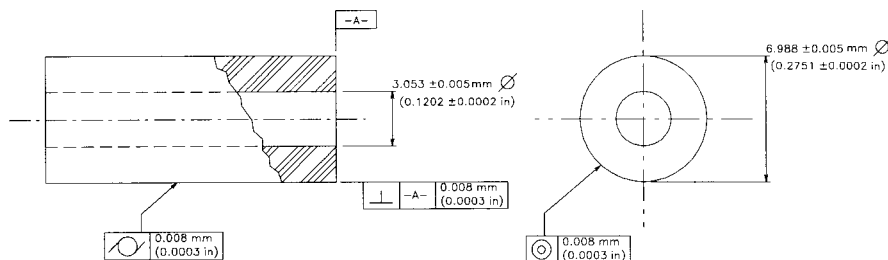

FIG. 2 Typical Dimensional Specifications for 7-mm Coaxial Test Specimens

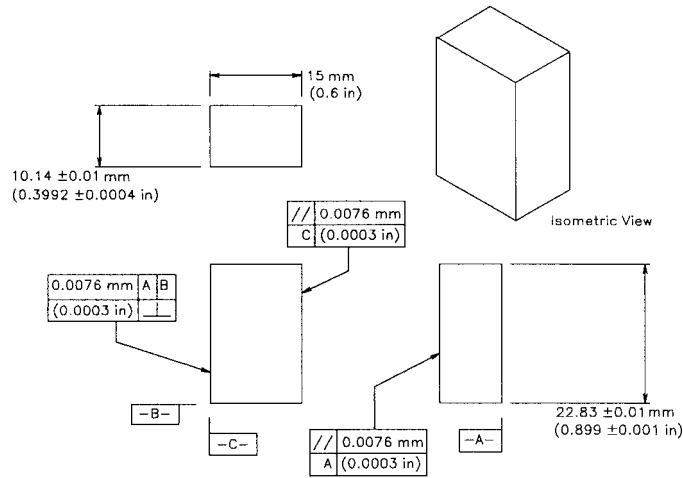

FIG. 3 Typical Dimensional Specifications for X-band Rectangular Wave-guide Test Specimens

9.2 *Flexing and Tightening Cables and Connectors*—Cable flexing and improperly tightened connectors introduce phase and magnitude errors into *S*-parameter data. For this reason, bend the test cables as little as possible, and under no circumstances bend the test cables smaller than the manufacturer’s minimum recommended radius. Insofar as possible, return the network analyzer cables to the same position during measurement of calibration standards and specimen. Use the proper torque wrench to tighten connectors. Use a 1.36 newton meter (12 in.-pound) torque wrench to tighten 7-mm coaxial connectors.

9.3 *Inspect and Clean Specimen, Specimen Holder, and Connectors*—Handle specimens with laboratory gloves (nylon, plastic, or latex) to avoid depositing oil onto a specimen. Clean specimens, connectors, and transmission lines using lint-free swabs and isopropyl alcohol (not less than 99 % pure). Blow out specimens, connectors, and transmission lines using filtered, pressurized air (not breath). Examine specimens for cracks and chips on their edges. Note any damage to specimens.

9.4 *Network Analyzer Setup:*

9.4.1 Turn on the network analyzer at least 1 h before beginning calibration and measurements.

9.4.2 For measurements made in a 50-Ω coaxial setup, set system and line impedances to 50 Ω. For rectangular wave guide measurements, set system and line impedances to 1 Ω. Set delay to either coaxial delay or rectangular wave guide delay, as appropriate. Set relative velocity factor to 1.000.

9.4.3 Put network analyzer into step frequency mode. Set the start frequency and stop frequency as desired. Set the number of measurement points to the desired value.

9.4.4 If available, set the network analyzer’s variable intermediate frequency (IF) bandwidth to less than 30 Hz, otherwise set the network analyzer data-averaging factor to a value >200.

9.4.5 Perform a two-port network analyzer calibration in accordance with the manufacturer’s procedures.

10. Procedure

10.1 The following procedure specifically applies to a 7-mm coaxial setup. Minor differences concerning the connector exist if other transmission line configurations are used. All other aspects of this procedure remain the same.

10.2 *Calibration Verification:*

10.2.1 Connect the empty specimen holder between Ports 1 and 2.

10.2.2 Measure the scattering parameters of the empty specimen holder.

10.2.3 Calculate the permittivity of air from the measured scattering parameters, as described in the section on calculation. Use a specimen length equal to the physical length of the specimen holder. If a method described in Appendix X2 is used to remove specimen holder conductor losses, use the appropriate specimen length, as described. To verify the calibration, the real part of permittivity for air should be 1.001 ± 0.001 .

10.3 *Specimen Measurement:*

10.3.1 Slide specimen about halfway onto the Port 1 side of the center conductor. Be careful not to chip the edges of the specimen’s bore hole when inserting the center conductor.

10.3.2 Note how the specimen fits on the center conductor (loose, snug, tight, loose at first, then tight, etc). This subjective observation helps the operator to determine the dimensional qualities of the specimen, and can aid in repeating the measurement.

10.3.3 Retract the connector threads at both ends of the specimen holder, if applicable.

10.3.4 Slide the specimen and center conductor into the outer conductor. Note how the specimen fits into the outer conductor. Leave the specimen sticking out of the Port 1 side about halfway.

10.3.5 Connect one end of the specimen holder to Port 2.

10.3.6 Bring the Port 1 connector and the Port 1 end of the specimen holder together in left hand, holding them slightly apart.

10.3.7 Use the end of a wood or plastic small-diameter dowel to push the specimen flush with the Port 1 reference plane. If the data-reduction algorithm to be used is not dependent on the specimen location, special care in making the specimen flush with the Port 1 reference plane is not necessary. Note the approximate location of the specimen relative to the Port 1 end of the specimen holder.

10.3.8 Slowly connect the Port 1 connectors. Look to make sure that the specimen does not protrude into the Port 1 test-cable connector. Tighten both Port 1 and Port 2 connectors with the proper torque wrench.

10.3.9 Measure the scattering parameters of the specimen holder containing a specimen. If one wishes to archive the scattering parameter data or to calculate permittivity and permeability at a later time, save the S -parameter data on disk.

10.3.10 Disconnect the Port 1 cable from the specimen holder. Disconnect the Port 2 cable from the specimen holder.

10.3.11 Remove the specimen from the Port 1 side of the specimen holder by pushing out the center conductor from the Port 2 side. Push the center conductor straight out, without applying lateral forces that may bend the center conductor and damage the specimen. Be careful that the specimen does not bind or twist.

10.4 *Reverify Calibration*—Measure the permittivity of air in the empty specimen holder at the beginning and end of specimen measurements and prior to any measurement when more than 2 h has lapsed since the previous air measurement.

11. Calculation

11.1 The selection of data reduction algorithm for calculation of material characteristics depends on whether the material is magnetic or nonmagnetic. In both of the following algorithms, specimen location is not critical. That is, the location of the specimen does not enter the solution.

11.2 The general procedure for both algorithms is to first generate initial estimates at all frequencies for permittivity (and permeability) using an explicit solution, and then to refine the initial estimates with an iterative technique. There are many possible solutions to the equations being used, and an initial estimate is necessary so as to select the proper root. Initial estimate calculation is not necessary if good permittivity and permeability estimates are available. One can determine if the initial estimates are reasonable by the stability of permittivity and permeability results. If the initial estimates start the iterative calculation on the wrong root, the calculated results tend to vary up and down and sometimes jump suddenly to another root. A set of equations relating scattering parameters and specimen length, permittivity and permeability is given as follows:⁵

$$F = S_{11}S_{22} - S_{21}S_{12} = \exp\{-2\gamma_0(L_{\text{air}} - L)\} \frac{\Gamma^2 - Z^2}{1 - \Gamma^2 Z^2} \quad (6)$$

$$G = (S_{21} + S_{12})/2 = \exp\{-\gamma_0(L_{\text{air}} - L)\} \frac{Z(1 - \Gamma^2)}{1 - \Gamma^2 Z^2}. \quad (7)$$

11.2.1 *Initial Estimate for Magnetic Materials*—If a good initial estimate for permittivity and permeability for each frequency is available, the calculations detailed in this section are not necessary. At each measured frequency, a solution similar to that described by Nicholson and Ross⁶ and by Weir⁷ for permittivity and permeability can be derived from (Eq 6) and (Eq 7) as follows:

$$\mu_{NRW}^* = \frac{1 + \Gamma_2}{1 - \Gamma_2} \frac{1}{\gamma_0 L} (\ln Z + j2\pi n). \quad (8)$$

$$\epsilon_{NRW}^* = \frac{c_0}{2\pi f \mu_{NRW}^*} \left[\left(\frac{2\pi}{\gamma_c} \right)^2 - \frac{1}{L^2} (\ln Z + j2\pi n)^2 \right] \quad (9)$$

The ambiguity in the plus-or-minus sign in Γ_2 can be resolved by choosing $|\Gamma_2| \approx |\Gamma_3| \leq 1$. Note that an estimate of the distance between the specimen and the Port 1 reference plane (L_1) is needed to estimate Γ_3 . Once Γ_2 is determined the correct value of n in (Eq 8) and (Eq 9) is picked by matching the measured and calculated group delay. First determine the measured group delay ($\tau_{\text{meas.group}}$). Use adjacent frequencies to estimate the differential with respect to frequency. The calculated group delays ($\tau_{\text{calc.group}}$) are then found for various values of n in the logarithm term found in the definition for Λ . In this definition, if W is a complex number, then:

$$\ln W = \ln |W| + j(\theta + 2\pi n) \quad (10)$$

where:

$$n = 0, \pm 1, \pm 2, \dots$$

11.2.2 *Initial Estimate for Nonmagnetic Materials*—If the material is strictly dielectric, set $\mu_{NRW}^* = 1$ (Eq 8) to find the value of $(\ln Z + 2\pi jn)$, then put this value into (Eq 9) to solve for ϵ_{NRW}^* .

11.2.3 *Iterative Algorithm for Magnetic Materials*—Separate the real and imaginary parts of Eq 6 and Eq 7 and take the total

⁵ Baker-Jarvis, J. R., Janezic, M. D., Grosvenor, J. H., and Geyer, R. G., "Transmission/Reflection and Short-Circuit Line Methods for Measuring Permittivity and Permeability," *NIST Technical Note 1355*, May 1992.

⁶ Nicholson, A. M., and Ross, G. F., "Measurement of the Intrinsic Properties of Materials by Time Domain Techniques," *IEEE Transactions on Instrumental Measurements*, Vol IM-19, November 1970, pp. 377–382.

⁷ Weir, W. B., "Automatic Measurement of Complex Dielectric Constant and Permeability at Microwave Frequencies," *IEEE Proceedings*, Vol 62, No. 1 January 1974, pp. 33–36.

differential with respect to ϵ'_{R} , ϵ''_{R} , μ'_{R} and μ''_{R} to generate a system of four real equations. In matrix form this looks like the following:

$$\begin{bmatrix} \frac{\partial \Re(F)}{\partial \epsilon'_{R}} & \frac{\partial \Re(F)}{\partial \epsilon''_{R}} & \frac{\partial \Re(F)}{\partial \mu'_{R}} & \frac{\partial \Re(F)}{\partial \mu''_{R}} \\ \frac{\partial \Im(F)}{\partial \epsilon'_{R}} & \frac{\partial \Im(F)}{\partial \epsilon''_{R}} & \frac{\partial \Im(F)}{\partial \mu'_{R}} & \frac{\partial \Im(F)}{\partial \mu''_{R}} \\ \frac{\partial \Re(G)}{\partial \epsilon'_{R}} & \frac{\partial \Re(G)}{\partial \epsilon''_{R}} & \frac{\partial \Re(G)}{\partial \mu'_{R}} & \frac{\partial \Re(G)}{\partial \mu''_{R}} \\ \frac{\partial \Im(G)}{\partial \epsilon'_{R}} & \frac{\partial \Im(G)}{\partial \epsilon''_{R}} & \frac{\partial \Im(G)}{\partial \mu'_{R}} & \frac{\partial \Im(G)}{\partial \mu''_{R}} \end{bmatrix} \begin{bmatrix} \Delta \epsilon'_{R} \\ \Delta \epsilon''_{R} \\ \Delta \mu'_{R} \\ \Delta \mu''_{R} \end{bmatrix} = \begin{bmatrix} \Delta \Re(F) \\ \Delta \Im(F) \\ \Delta \Re(G) \\ \Delta \Im(G) \end{bmatrix} \quad (11)$$

where the four-by-four matrix is the Jacobian of the system of four equations. In matrix notation the discretized system of equations can be represented as follows:

$$J\Delta X = Y, \quad (12)$$

where we define the vector X as the estimated values of permittivity and permeability, and the vector ΔX contains the estimated corrections for permittivity and permeability for use in the next iteration as follows:

$$X = \begin{Bmatrix} \epsilon'_{R} \\ \epsilon''_{R} \\ \mu'_{R} \\ \mu''_{R} \end{Bmatrix} \quad \Delta X = \begin{Bmatrix} \Delta \epsilon'_{R} \\ \Delta \epsilon''_{R} \\ \Delta \mu'_{R} \\ \Delta \mu''_{R} \end{Bmatrix} \quad (13)$$

If we solve for ΔX we get

$$\Delta X = J^{-1}Y. \quad (14)$$

To solve for permittivity and permeability, start with an initial estimate of X and calculate ΔX . The functional iteration procedure would then be:

$$X^{new} = X^{old} + J^{-1}Y \quad (15)$$

Repeat this process until $X^{new} \approx X^{old}$. At which point the converged values of permittivity and permeability have been found.

11.2.4 Iterative Algorithm for Nonmagnetic Materials—The process of finding permittivity for nonmagnetic materials is identical to that used in 11.2.3, except that the differentials with respect to permeability are zero, and J reduces to a two-by-two matrix. Only two independent real equations are necessary to solve for permittivity, so use either (Eq 6) or (Eq 7). For low-loss materials (Eq 7) works better than (Eq 6), whereas for high-loss materials ($S_{21} < 40$ dB) (Eq 6) converges to a more stable result.

11.3 Air Gap Correction—Apply a correction for the air gap that exists between the specimen and transmission line conductor(s) (see Annex A2).

12. Report

12.1 Report the following information:

- 12.1.1 Operator name, time and date of measurement,
- 12.1.2 Type of calibration (TRL, OSLT, etc),
- 12.1.3 Start and stop frequencies, number of points, averaging factor, type of frequency sweep, system and line impedances, relative velocity factor,
- 12.1.4 Computational algorithm name,
- 12.1.5 Calculated values of the permittivity of air at each measurement frequency as measured at the beginning and end of the measurement cycle and at 2-h intervals, if applicable,
- 12.1.6 Test specimen identification,
- 12.1.7 Specimen dimensions and uncertainties used in data reduction,
- 12.1.8 Type of specimen holder (coaxial line or rectangular wave guide; fixed or movable thread),
- 12.1.9 Specimen holder dimensions and uncertainties used in data reduction,
- 12.1.10 Subjective description of specimen fit and estimated location of specimen in specimen holder (see 10.3.2, 10.3.4, and 10.3.7),
- 12.1.11 Estimated gap sizes between specimen and conductor(s) used in the computation. For coaxial lines this includes the gap between the specimen and the center conductor as well as the gap between the specimen and the outer conductor. For wave guides this includes the gap between the specimen and the specimen holder's wide wall as well as the gap between the specimen and the specimen holder's narrow wall. Describe how gap sizes were estimated, and
- 12.1.12 Calculated values of permittivity and permeability for the test specimen at each measurement frequency.

13. Precision and Bias

13.1 Precision—It is not practicable to specify the precision of the procedure in this test method for measuring permittivity and permeability because several transmission line sizes and types can be used as specimen holders for this technique. In specific applications, it is possible to estimate measurement precision by estimating the uncertainties of the measured scattering parameters

and specimen dimensions, and then applying a differential analysis to the given equations.⁴

13.2 *Bias*—Bias of the procedure in this test method for measuring permittivity and permeability primarily depends on proper estimation of air-gap dimensions. Existence of air-gaps between the specimen and the specimen holder causes a negative bias to both permittivity and permeability calculations. Remove this bias by applying the corrections described in Annex A2. The magnitude of the air-gap correction depends on the value of permittivity and permeability, and on the relative size of air gaps in the several possible transmission line geometries.

14. Keywords

14.1 coaxial line; dielectric constant; magnetic permeability; measurement; microwave; millimetre-wave; permittivity; radio frequency; rectangular wave guide; scattering parameter; transmission/reflection

ANNEXES
(Mandatory Information)
A1. LIST OF SYMBOLS

A1.1

j	$= \sqrt{-1}$	The complex constant
L_{air}		Length of transmission line
L		Length of specimen
L_1		Distance between Port 1 reference plane and specimen
ϵ_{R}^{*}	$= \epsilon'_{R} - j\epsilon''_{R}$	Relative complex permittivity
μ_{R}^{*}	$= \mu'_{R} - j\mu''_{R}$	Relative complex permeability
ϵ	$= \epsilon' - j\epsilon''$	Absolute complex permittivity of material
μ	$= \mu' - j\mu''$	Absolute complex permeability of material
f		Measurement frequency (Hz)
c_0	$= 2.99792458 \times 10^8$	Speed of light in vacuum (m/s)
λ_c		Wave guide cutoff wavelength
λ_0	$= \frac{c_0}{f}$	Wavelength in free space
γ_0	$= j2\pi \sqrt{\frac{f^2}{c_{\text{air}}^2} - \frac{1}{\lambda_c^2}}$	Propagation constant in air
γ	$= j2\pi \sqrt{\frac{f^2 \mu_{R}^{*} \epsilon_{R}^{*}}{c_0^2} - \frac{1}{\lambda_c^2}}$	Propagation constant in material

V_1	$= S_{21} + S_{11}$	
V_2	$= S_{21} - S_{11}$	
X	$= \frac{1 - V_1 V_2}{V_1 - V_2}$	
α	$= \exp(-2\gamma_0 L_1)$	
x	$= (S_{21} S_{12} - S_{11} S_{22}) \exp \{2\gamma_0 (L_{\text{air}} - L)\}$	
y	$= \frac{S_{21} + S_{12}}{2} \{\gamma_0 (L_{\text{air}} - L)\}$	
Z	$= \exp(-\gamma L)$	Transmission coefficient
Z_1	$= \frac{S_{11} + S_{21} - \Gamma_1}{1 - (S_{11} + S_{21})\Gamma_1}$	Transmission coefficient for the explicit Nicholson-Ross-Weir algorithm
Z_p	$= \frac{x+1}{2y} \pm \sqrt{\left(\frac{x+1}{2y}\right)^2 - 1}$	Physical roots of transmission coefficient
Γ	$= \frac{(\mu/\gamma) - (\mu_0/\gamma_0)}{(\mu/\gamma) + (\mu_0/\gamma_0)}$	Reflection coefficient for <i>TE</i> and <i>TEM</i> modes
Γ_1	$= X \pm \sqrt{X^2 - 1}$	Reflection coefficient used in explicit Nicholson-Ross-Weir algorithm
Γ_2	$= \pm \frac{x - Z_p^2}{xZ_p^2 - 1}$	Physical roots for reflection coefficient
Γ_3	$= \frac{\alpha(Z_p^2 - 1) \pm \sqrt{\alpha^2 Z_p^4 + 2Z_p^2(2S_{11} - \alpha^2) + \alpha^2}}{2S_{11}Z_p^2}$	Reflection coefficient calculated from S_{11} only. $ \Gamma_3 \leq 1$.
Λ	$= \left(\frac{j}{2\pi L} \ln\left(\frac{1}{Z_1}\right)\right)^{-1}$	
μ^*_{NRW}	$= \frac{1 + \Gamma_1}{(1 - \Gamma_1)\Lambda \sqrt{\lambda_0^2 - \lambda_c^2}}$	Permeability calculated in explicit Nicholson-Ross-Weir algorithm
ϵ^*_{NRW}	$= \frac{\lambda_0^2}{\mu^*_{NRW}} (\Lambda_c^2 - \Lambda^{-2})$	Permittivity calculated in <i>NRW</i> algorithm
ϕ		Phase of Z_1
$\tau_{calc.group}$	$= \frac{L}{c_0^2} \frac{f \epsilon^*_{NRW} \mu^*_{NRW} + f^2 \frac{1}{2} \frac{d(\epsilon^*_{NRW} \mu^*_{NRW})}{df}}{\sqrt{\epsilon^*_{NRW} \mu^*_{NRW} \lambda_0^2 - \lambda_c^2}}$	Group delay calculated from possible values of ϵ^*_{NRW} and μ^*_{NRW}
$\tau_{meas.group}$	$= \frac{1}{2\pi} \frac{d\phi}{df}$	Measured group delay calculated from phase of Z_1
D_1		Diameter of coaxial transmission line center conductor
D_2		Diameter of coaxial specimen's inner bore
D_3		Outer diameter of coaxial specimen
D_4		Diameter of coaxial transmission line outer conductor
K_1	$= \ln \frac{D_2}{D_1} + \ln \frac{D_4}{D_3}$	
K_2	$= \ln \frac{D_3}{D_2}$	
K_3	$= \ln \frac{D_4}{D_1}$	

b		Height (small transverse dimension) of rectangular wave guide
d		Height (small transverse dimension) of rectangular specimen
ϵ'_{m}		“Measured” relative permittivity calculated directly from S-parameters
ϵ''_{m}		Dielectric loss index calculated from S-parameters
ϵ'_{c}		Air-gap corrected relative permittivity
ϵ''_{c}		Air-gap corrected dielectric loss index
μ'_{m}		“Measured” relative permeability calculated directly from S-parameters
μ''_{m}		Magnetic loss index calculated from S-parameters
μ'_{c}		Air-gap corrected relative permeability
μ''_{c}		Air-gap corrected magnetic loss index
Δ_{me}	$= \frac{\epsilon''_{m}}{\epsilon'_{m}}$	“Measured” dielectric loss tangent

A2. FREQUENCY INDEPENDENT SERIES CAPACITOR MODEL FOR AIR-GAP CORRECTIONS

A2.1 The air gaps that exist between a transmission line and a specimen can be modulated by a set of capacitors in series. In the case of coaxial transmission lines, the model assumes three capacitors in series. In the case of rectangular wave guides, the model assumes two capacitors in series.

A2.2 Air Gap Correction for Coaxial Transmission Lines:

A2.2.1 Correction for real part of relative permittivity is as follows:

$$\epsilon'_{c} = \epsilon'_{m} \frac{K_{3} (1 + \Delta_{me}^2)}{K_{2}[K_{3} - K_{1}\epsilon'_{R}(1 + \Delta_{me}^2)]^2 + K_{3}\Delta_{me}^2} \quad (\text{A2.1})$$

A2.2.2 Correction for dielectric loss index is as follows:

$$\epsilon''_{c} = \epsilon'_{c} \arctan \frac{K_{3}\Delta_{me}}{K_{3} - L_{1}\epsilon'_{m}[1 + \Delta_{me}^2]} \quad (\text{A2.2})$$

A2.2.3 Correction for real part of permeability is as follows:

$$\mu'_{c} = \frac{\mu'_{m}K_{3} - K_{1}}{K_{2}} \quad (\text{A2.3})$$

A2.2.4 Correction for imaginary part of permeability is as follows:

$$\mu''_{c} = \mu'_{m} \frac{K_{3}}{K_{2}} \quad (\text{A2.4})$$

A2.3 Air Gap Correction for Rectangular Wave Guides:

A2.3.1 Correction for real part of relative permittivity is as follows:

$$\epsilon'_{c} = \epsilon'_{m} \frac{d(1 + \Delta_{me}^2)[b - (b - d)\epsilon'_{m}(1 + \Delta_{me}^2)]}{[b - (b - d)\epsilon'_{m}(1 + \Delta_{me}^2)]^2 + b^2\Delta_{me}^2} \quad (\text{A2.5})$$

A2.3.2 Correction for imaginary part of permittivity is as follows:

$$\epsilon''_{c} = \epsilon'_{c} \frac{b\Delta_{me}}{[b - (b - d)\epsilon'_{m}(1 + \Delta_{me}^2)]} \quad (\text{A2.6})$$

A2.3.3 Correction for real part of permeability is as follows:

$$\mu'_{c} = \mu'_{m} \left(\frac{b}{d} \right) - \left(\frac{b - d}{d} \right) \quad (\text{A2.7})$$

A2.3.4 Correction for imaginary part of permeability is as follows:

$$\mu''_{c} = \mu'_{m} \left(\frac{b}{d} \right) \quad (\text{A2.8})$$

APPENDIXES**(Nonmandatory Information)****X1. ESTIMATE OF UNCERTAINTY OF ϵ AND μ MEASURED VALUES**

X1.1 Conductive paints, powders, greases, etc may be used on either the specimen or specimen holder to reduce air gaps between the airline conductor(s) and the specimen. However, the application of these substances will introduce a positive bias into the measurement of loss index (ϵ''_R), and could contaminate porous specimens or specimens that chemically react with the applied substance. Additionally, measurements will be greatly affected if the applied substance is deposited on the specimen ends.

X1.2 The sources of error in permeability and permittivity measurement include:

- (1) Errors in measuring the magnitude and phase of the scattering parameters,
- (2) Gaps between the specimen and specimen holder,
- (3) Specimen holder dimension variations,
- (4) Uncertainty in the specimen length,
- (5) Line losses and connector mismatch, and
- (6) Uncertainty in reference plane positions.

A differential uncertainty analysis is applied by Baker-Jarvis, et al.⁴ in order to evaluate the uncertainty introduced by the measured scattering parameters and specimen dimensions.

X2. REMOVAL OF SPECIMEN HOLDER CONDUCTOR LOSSES

X2.1 Calibrate the network analyzer with the specimen holder connected to Port 2.

X2.1.1 This method is most convenient with rectangular wave guides, but can also be adapted for use with coaxial lines.

X2.1.2 The loss of the line is taken out in calibration, and Port 1 and Port 2 reference planes defined by the calibration will be flush with one another during the measurement of specimen(s).

X2.1.3 To verify the calibration, remove the specimen holder, measure the scattering parameters, and calculate the permittivity of air. Use the negative of the physical length of the specimen holder in this calculation.

X2.1.4 Reattach the specimen holder.

X2.1.5 Measure material specimen(s) of interest as described in the procedure section.

X2.1.6 Calculate specimen permittivity and permeability using a specimen holder length equal to zero.

X2.2 Redefine the short, open, load, through (SOLT) “through” standard to include the specimen holder.

X2.2.1 This method is somewhat more difficult than the first method in that it requires the operator to redefine a calibration kit standard.⁸

X2.2.2 This method can be done only with a full two-port SOLT calibration.

X2.2.3 In redefining the through calibration standard, use the electrical length of the specimen holder and set its loss equal to zero.

X2.2.4 To verify the calibration, remove the specimen holder, measure the scattering parameters and calculate the permittivity of air using a specimen holder length equal to zero.

X2.2.5 Proceed with specimen measurement as outlined in the procedure section. In calculating permittivity and permeability, set the length of the specimen holder equal to its physical length.

⁸ Concepts for specifying network analyzer calibration standards can be found in *Hewlett-Packard Application Note 8510-5A*, “Specifying calibration standards for the HP 8510 network analyzer,” Hewlett-Packard Co., 1400 Fountaingrove Parkway, Santa Rosa, CA 95403.

X3. COMPUTER PROGRAM FOR CALCULATING ϵ AND μ

X3.1 The following computer program is written in Rocky Mountain BASIC version 5.13.⁹

X3.2 Variable definitions are as follows (see Figs. X3.1-X3.3):

X3.2.1 Eps_nr(I) and Mu_nr(I) are initial estimates for permittivity and permeability for each frequency Freq(I).

X3.2.2 Alpha(I,J) corresponds to the four-by-four Jacobean matrix J , with Inv_alpha(I,J) equal to its inverse J^{-1} .

X3.2.3 X(I) and Delta_x(I) correspond to the vectors X and ΔX .

⁹ Software available from the Hewlett-Packard Company, and from the National Institute of Standards and Technology (NIST), Boulder CO.

```

10  SUB Calc_eps_mu
20  DIM Alpha(4,4),Beta(4),X(4),Delta_x(4),Temp(4,4)
30  Init_const: !
40  Num_trials=50
50  Num_equations=4
60  Delta=1.E-8
70  Tolf=1.E-8
80  Tolx=1.E-8
90  Calc_eps_mu: !
100 IF ABS(Init_eps)=0 THEN
110   Init_eps=CMPLX(REAL(Eps_nr(1)),IMAG(Eps_nr(1)))
120 END IF
130 IF ABS(Init_mu)=0 THEN
140   Init_mu=CMPLX(REAL(Mu_nr(1)),IMAG(Mu_nr(1)))
150 END IF
160 FOR I=1 TO Datacount
170   IF I=1 THEN
180     X(1)=REAL(Init_eps)
190     X(2)=IMAG(Init_eps)
200     X(3)=REAL(Init_mu)
210     X(4)=IMAG(Init_mu)
220   ELSE
230     X(1)=REAL(Eps(I-1))
240     X(2)=IMAG(Eps(I-1))
250     X(3)=REAL(Mu(I-1))
260     X(4)=IMAG(Mu(I-1))
270     ON ERROR RECOVER Crash
280     DISP "CALCULATING MU/EPSILON (ITERATIVE SOLUTION) FOR
POINT #";I;" ..."
290   END IF
300   FOR J=1 TO Num_trials
310     FOR K=1 TO Num_equations
320       FOR L=1 TO Num_equations
330         Alpha(K,L)=FNDpm(I,K,L,X(*),Delta)
340       NEXT L
350       Beta(K)=-FNTwo(I,K,X(*))
360     NEXT K
370     Errf=0
380     FOR K=1 TO Num_equations
390       Errf=Errf+ABS(Beta(K))
400     NEXT K
410     IF Errf<Tolf THEN GOTO Converged
420     MAT Temp=INV(Alpha)
430     MAT Delta_x=Temp*Beta
440     Errf=0
450     FOR K=1 TO Num_equations
460       Errf=Errf+ABS(Delta_x(K))

```

FIG. X3.1 Program for Calculating ϵ and μ

```

470          X(K)=X(K)+Delta_x(K)
480          NEXT K
490          IF Errf<Tolx THEN GOTO Converged
500          NEXT J
510 Converged: !
520          IF X(2)<0 THEN X(2)=0
530          Eps(I)=CMPLX(X(1),X(2))
540          IF X(4)<0 THEN X(4)=0
550          Mu(I)=CMPLX(X(3),X(4))
560          NEXT I
570          OFF ERROR
580          Init_eps=0
590          Init_mu=0
600          SUBEND ! Calc_eps_mu
610 !
620 ! *****
630 !
640          DEF FNDpm(I,K,L,X(*),Delta)
650          DIM Y(4),Yy(4)
660 Fndpm: !
670          FOR M=1 TO 4
680              Y(M)=X(M)
690              Yy(M)=X(M)
700          NEXT M
710          Y(L)=Y(L)+Delta
720          Yy(L)=Yy(L)-Delta
730          X1=FNTwo(I,K,Y(*))
740          X2=FNTwo(I,K,Yy(*))
750          RETURN (X1-X2)/Delta/2
760          FNEND
770 !
780          DEF FNTwo(I,K,X(*))
790          COMPLEX J,Ep,M,Lambda_c,Gamma,Gamma0,Gamma1,Za,Zb,Beta,X1,X2,Delta
800          COMPLEX Dummy1,Dummy2,Dummy3
810          Init_const: !
820              Eps0=8.854188E-12
830              Mu0=(4*PI)*1.E-7
840              J=CMPLX(0,1)
850          Fntwo: !
860              W=2*PI*Freq(I)
870              W_cut=2*PI*Fco
880              Ep=CMPLX(X(1),-X(2))
890              M=CMPLX(X(3),-X(4))
900              Lambda_c=C_lab/Fco
910              Gamma1=J*SQR(((W^2)*Ep*M*Eps0*Mu0)-(((2*PI)/(Lambda_c))^2))
920              Gamma0=J*SQR((W^2)/(C_lab^2)-(((2*PI)/(Lambda_c))^2))
930              Gamma=((M/Gamma1)-(1/Gamma0))/((M/Gamma1)+(1/Gamma0))

```

FIG. X3.1 (continued)

```

940      Za = EXP(-Gamma1*Sample_length_a)
950      Zb = EXP(-Gamma1*Sample_length_b)
960      IF (K=1) OR (K=2) THEN
970          Dummy1 = S21a(I)*S12a(I)-S11a(I)*S22a(I)
980          Dummy2 = EXP(-2*Gamma0*(Airline_length-Sample_length_a))
990          Dummy3 = ((Za^2)-(Gamma^2))/(1-((Za^2)*(Gamma^2)))
1000         IF K=1 THEN
1010             RETURN REAL(Dummy1-(Dummy2*Dummy3))
1020         ELSE
1030             RETURN IMAG(Dummy1-(Dummy2*Dummy3))
1040         END IF
1050     ELSE
1060         IF (K=3) OR (K=4) THEN
1070             Dummy1 = (S21a(I) + S12a(I))/2
1080             Dummy2 = EXP(-1*Gamma0*(Airline_length-Sample_length_a))
1090             Dummy3 = (Za*(1-Gamma^2))/(1-((Gamma^2)*(Za^2)))
1100             IF K=3 THEN
1110                 RETURN REAL(Dummy1-(Dummy2*Dummy3))
1120             ELSE
1130                 RETURN IMAG(Dummy1-(Dummy2*Dummy3))
1140             END IF
1150         END IF
1160     END IF
1170 FNEND

```

FIG. X3.1 (continued)

ASTM International takes no position respecting the validity of any patent rights asserted in connection with any item mentioned in this standard. Users of this standard are expressly advised that determination of the validity of any such patent rights, and the risk of infringement of such rights, are entirely their own responsibility.

This standard is subject to revision at any time by the responsible technical committee and must be reviewed every five years and if not revised, either reapproved or withdrawn. Your comments are invited either for revision of this standard or for additional standards and should be addressed to ASTM International Headquarters. Your comments will receive careful consideration at a meeting of the responsible technical committee, which you may attend. If you feel that your comments have not received a fair hearing you should make your views known to the ASTM Committee on Standards, at the address shown below.

This standard is copyrighted by ASTM International, 100 Barr Harbor Drive, PO Box C700, West Conshohocken, PA 19428-2959, United States. Individual reprints (single or multiple copies) of this standard may be obtained by contacting ASTM at the above address or at 610-832-9585 (phone), 610-832-9555 (fax), or service@astm.org (e-mail); or through the ASTM website (www.astm.org).