



Designation: D 1816 – 03⁴

Standard Test Method for Dielectric Breakdown Voltage of Insulating Oils of Petroleum Origin Using VDE Electrodes¹

This standard is issued under the fixed designation D 1816; the number immediately following the designation indicates the year of original adoption or, in the case of revision, the year of last revision. A number in parentheses indicates the year of last reapproval. A superscript epsilon (ϵ) indicates an editorial change since the last revision or reapproval.

1. Scope

1.1 This test method covers the determination of the dielectric breakdown voltage of insulating oils of petroleum origin. This test method is applicable to liquid petroleum oils commonly used in cables, transformers, oil circuit breakers, and similar apparatus as an insulating and cooling medium. The suitability of this test method for testing oils having viscosity of more than 19 cSt, (100SUS) at 40°C (104°F) has not been determined. Refer to Terminology D 2864 for definitions used in this test method.

1.2 This test method is sensitive to the deleterious effects of moisture in solution especially when cellulosic fibers are present

¹ This test method is under the jurisdiction of ASTM Committee D27 on Electrical Insulating Liquids and Gases and is the direct responsibility of Subcommittee D27.05 on Electrical Tests.

Current edition approved Oct. 1, 2003. Published December 2003. Originally approved in 1960 as D 1816 – 60 T. Last previous edition approved in 1997 2003 as D 1816 – 9703.

in the oil. It has been found to be especially useful in diagnostic and laboratory investigations of the dielectric breakdown strength of oil in insulating systems.²

1.3 This test method is used to judge if the VDE electrode breakdown voltage requirements are met for insulating liquids. This test method should be used as recommended by professional organization standards such as IEEE C57.106.

1.4 This test method may be used to obtain the dielectric breakdown of silicone fluid as specified in Test Method D 2225, provided that the discharge energy into the sample is less than 20 mJ (milli joule) per breakdown for five consecutive breakdowns.

1.5 Both the metric and the alternative inch-pound units are acceptable.

1.6 *This standard does not purport to address all of the safety concerns, if any, associated with its use. It is the responsibility of the user of this standard to establish appropriate safety and health practices and determine the applicability of regulatory limitations prior to use.*

2. Referenced Documents

2.1 ASTM Standards:³

D 235 Specification for Mineral Spirits (Petroleum Spirits) (Hydrocarbon Dry Cleaning Solvent)

D 923 Practice for Sampling Electrical Insulating Liquids

D 2225 Test Method for Silicone Fluids Used for Electrical Insulation

D 2864 Terminology Relating to Electrical Insulating Liquids and Gases

D 3487 Specification for Mineral Insulating Oil Used in Electrical Apparatus

2.2 IEEE Standard:

Standard 4 IEEE Standard Techniques for High Voltage Testing⁴

C57.106 Guide for Acceptance and Maintenance of Insulating Oil in Equipment⁴

3. Significance and Use

3.1 The dielectric breakdown voltage of an insulating liquid is of importance as a measure of the liquid's ability to withstand electric stress without failure. The dielectric breakdown voltage serves to indicate the presence of contaminating agents such as water, dirt, cellulosic fibers, or conducting particles in the liquid, one or more of which may be present in significant concentrations when low breakdown voltages are obtained. However, a high dielectric breakdown voltage does not necessarily indicate the absence of all contaminants; it may merely indicate that the concentrations of contaminants that are present in the liquid between the electrodes are not large enough to deleteriously affect the average breakdown voltage of the liquid when tested by this test method (see Appendix X1.)

3.2 This test method is used in laboratory or field tests. For field breakdown results to be comparable to laboratory results, all criteria including room temperature (20 to 30°C) must be met.

4. Electrical Apparatus

4.1 In addition to this section, use IEEE Standard 4 to determine other requirements necessary for conducting test measurements, and maintaining error limits using alternating voltages. Procedures to ensure accuracy should follow the requirements of IEEE Standard 4. Calibration(s) shall be traceable to national standards and calibration should be verified annually or more often to ensure accuracy requirements. IEEE Standard 4 is required during the manufacturing of the test apparatus and utilized during calibration of the equipment.

4.1.1 *Test Voltage*—The test voltage shall be an alternating voltage having a frequency in the range from 45 to 65 Hz, normally referred to as power-frequency voltage. The voltage wave shape should approximate a sinusoid with both half cycles closely alike, and it should have a ratio of peak-to-rms values equal to the square root of 2 within $\pm 5\%$.

4.1.2 *Generation of the Test Voltage*— The test voltage is generally supplied by a transformer or resonant circuit. The voltage in the test circuit should be stable enough to be unaffected by varying current flowing in the capacitive and resistive paths of the test circuit. Non-disruptive discharges in the test circuit should not reduce the test voltage to such an extent, and for such a time, that the disruptive discharge (breakdown) voltage of the test specimen is significantly affected. In the case of a transformer, the short-circuit current delivered by the transformer should be sufficient to maintain the test voltage within 3 % during transient current pulses or discharges, and a short circuit current of 0.1 A may suffice.

4.1.3 *Disruptive Voltage Measurement*— Design the measurement circuit so the voltage recorded at the breakdown is the maximum voltage across the test specimen immediately prior to the disruptive breakdown, with an error no greater than 3 %.

4.2 *Circuit-Interrupting Equipment*— Design the circuit used to interrupt the disruptive discharge through the specimen to operate when the voltage across the specimen has collapsed to less than 100 V. It is recommended that the circuit design limit the disruptive current duration and magnitude to low values that will minimize damage to the electrodes and limit formation of

² Supporting data is available from ASTM Headquarters. Request RR:D27-1006.

³ For referenced ASTM standards, visit the ASTM website, www.astm.org, or contact ASTM Customer Service at service@astm.org. For Annual Book of ASTM Standards volume information, refer to the standard's Document Summary page on the ASTM website.

⁴ Available from the Institute of Electrical and Electronic Engineers, Inc., PO Box 1331, Piscataway, NJ 08855.

non-soluble materials resulting from the breakdown, but consistent with the requirements of 4.1.2, but in no case should the short-circuit current exceed 1 mA/kV of applied voltage.

4.3 *Voltage Control Equipment*—Use a rate of voltage rise of 0.5 kV/s. The tolerance of the rate of rise should be 5 % for any new equipment manufactured after the year 2000. Automatic equipment should be used to control the voltage rate of rise because of the difficulty of maintaining a uniform voltage rise manually. The equipment should produce a straight-line voltage-time curve over the operating range of the equipment. Calibrate and label automatic controls in terms of rate-of-rise.

4.4 *Measuring Systems*—The voltage shall be measured by a method that fulfills the requirements of IEEE Standard No. 4, giving rms values.

4.5 Connect the electrode such that the voltage measured from each electrode with respect to ground during the test is equal within 5 %.

4.6 *Accuracy*—The combined accuracy of the voltmeter and voltage divider circuit shall be such that measurement error does not exceed 3 % at the rate-of-voltage rise specified in 4.3. For equipment manufactured prior to 1995 the maximum allowable error is 5 %.

5. Electrodes

5.1 The electrodes shall be polished brass spherically-capped electrodes of the VDE (Verband Deutscher Elektrotechniker, Specification 0370) type having the dimensions shown in Fig. 1 ± 1 %, mounted with axes horizontal and coincident within ± 1 mm.

6. Test Cell

6.1 Construct the test cell as a cube. The test cell shall be designed to permit easy removal of the electrodes for cleaning and polishing, verification that the shape is within the specified tolerance, and to permit easy adjustment of the gap spacing. The vector sum of the resistive and capacitive current of the cup, when filled with oil meeting the requirements of Specification D 3487, shall be less than 200 μ A at 20 kV, at power frequency. A test cell having a capacity of 0.95 L ± 5 %, has been found to be satisfactory for an electrode spacing of 2 mm. A cell having a capacity of 0.5 L ± 5 % has been found to be satisfactory for an electrode spacing of 1 mm. Mount the electrodes rigidly from opposite sides with the spacing axially centered within ± 1 mm. Clearance from the electrodes to all sides, bottom, cover or baffle, and any part of the stirring device is at least 12.7 mm ($\frac{1}{2}$ in.). Provide the test cell with a motor-driven two-bladed impeller and drive shaft, constructed of a material having high dielectric strength. The two-bladed impeller is 35 mm ($1\frac{3}{8}$ in.) ± 5 % between the blade extremities, having a pitch of 40 mm (1.57 in.) ± 5 % (blade angle of twenty degrees (20°) ± 5 %), operating at a speed between 200 and 300 rpm. The impeller, located below the lower edge of the electrodes, rotates in such a direction that the resulting liquid flow is directed downward against the bottom of the test cell. Construct the test cell of a material of high dielectric strength, that is not soluble in or attacked by any of the cleaning or test liquids used, and is nonabsorbent to moisture and the cleaning and test liquids. So that the breakdown may be observed, transparent materials are desirable, but not essential. In order to preclude stirring air with the sample, provide the cell with a cover or baffle that will effectively prevent air from contacting the circulating liquid.

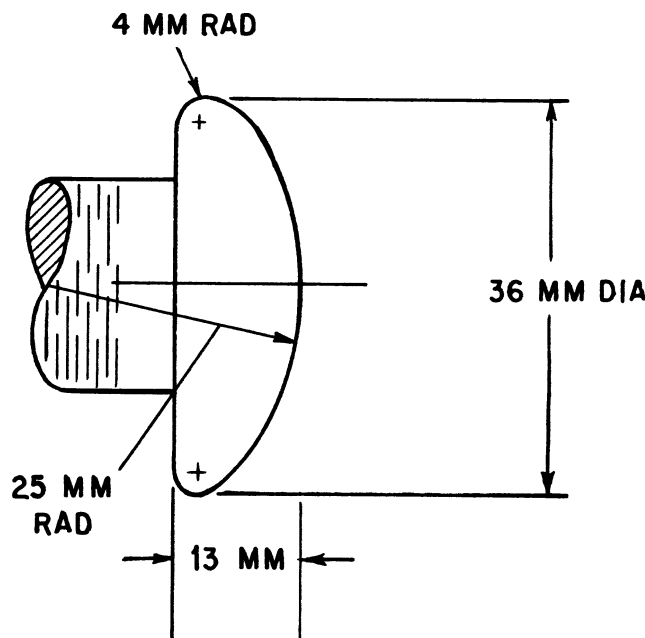

FIG. 1 VDE Electrode

7. Adjustment and Care of Electrodes and Test Cell

7.1 *Electrode Spacing*—With the electrodes firmly locked in position, check the electrodes with a standard round gage for 2 ± 0.03 -mm (0.079-in.) spacing. If a dielectric breakdown does not occur during any of the consecutive breakdown tests using the 2 mm spacing or the sample is not adequate for the 2 mm spacing test cell a 1 ± 0.03 -mm (0.039-in.) spacing should be used to determine the breakdown voltage and the spacing reported. Flat “go” and “no-go” gages may be substituted having thicknesses of the specified value ± 0.03 mm for electrode spacing of 1 or 2 mm. If it is necessary to readjust the electrodes, lock the electrodes and check the spacing. For referee tests or tests that will be used for close comparisons, the laboratories shall agree in advance on the spacing for the tests and ensure that all other requirements of this test method are met. The spacing agreed upon shall be measured with the gage that corresponds exactly to the selected spacing within tolerance stated above for the gage.

7.2 *Cleaning*—Wipe the electrodes and cell clean with dry, lint-free tissue paper, or a clean dry chamois. It is important to avoid touching the electrodes or the cleaned gage with the fingers or with portions of the tissue paper or chamois that have been in contact with the hands. After adjustment of the spacing, rinse the cell with a dry hydrocarbon solvent, such as kerosine or solvents of Specification D 235. Do not use a low boiling point solvent, as its rapid evaporation may cool the cell, causing moisture condensation. If this occurs, before using, warm the cell to evaporate the moisture. Avoid touching the electrodes or the inside of the cell after cleaning. After thorough cleaning, flush the cell with new oil of the type to be tested that is filtered through a 5-micron filter and containing less than 25 ppm moisture. Conduct a voltage breakdown test on a specimen of this oil in the manner specified in this test method. If the breakdown voltage is in the expected range for this conditioned oil, the cell is considered properly prepared for testing other samples. A lower than anticipated value is considered as evidence of cell contamination; then repeat the cleaning and the breakdown test with clean dry oil.

7.3 *Daily Use*—At the beginning of each day’s testing, the electrodes shall be examined for pitting and carbon accumulation, and the spacing checked. If the test of any sample is below the breakdown value being used by the operator as a minimum satisfactory value, drain the cell and flush the cell with new oil of the type to be tested that is filtered through a 5-micron filter and containing less than 25 ppm moisture before testing the next specimen. When not in use, keep the cell filled with oil that meets the requirements of Specification D 3487 of the type normally tested. Alternatively, the cell may be stored empty in a dust-free cabinet. At the beginning of each days testing, clean according to 7.2.

7.4 *Polishing of Electrodes*—When electrodes show slight etching, scratching, pitting, or carbon accumulation, they should be removed from the test cup and polished by buffing with jeweler’s rouge using a soft cloth or soft buffing wheel. The residue from the buffing should be removed by repeated wiping with lint-free tissue paper saturated with a suitable solvent, followed by solvent rinsing or ultrasonic cleaning. After careful inspection, any electrodes from which pitting cannot be removed by light buffing should be discarded, as more refinishing would destroy the electrode contour and dimensions shown in Fig. 1. Reinstall the electrodes in the test cup and adjust spacing and clean in accordance with 7.1 and 7.2.

8. Sampling

8.1 Obtain a sample of the oil to be tested using appropriate ASTM sampling apparatus. Oil sampling procedures are detailed in Practice D 923. Particular reference should be made to the general precaution statement of this test method. The sample shall be taken in a dry, clean, non-permeable bottle. Tightly seal and shield from light until ready to be tested. Plastic bottles are permeable and moisture content of the sample may change resulting in a measurable difference when compared to samples collected in non-permeable containers.

9. Test Procedure

9.1 Allow the sample and the test cup to equilibrate to ambient temperature. Laboratory and referee tests shall be conducted at room temperature (20 to 30°C).

9.2 To ensure a homogenous sample, gently invert and swirl the sample container several times. Rapid agitation is undesirable, since an excessive amount of air may be introduced into the liquid. Within 1 min after agitation, use a small portion of the sample to rinse the test cell. Drain the rinse. Within 30 s of the rinse, fill the cell slowly with the remaining portion of the sample. The cell is full when closing the cover or baffle allows no air to be in contact with the oil.

9.3 Wait at least 3 min but no more than 5 min between filling the cup and application of voltage for the first breakdown. Apply the voltage increasing from zero at the rate of $0.5 \text{ kV/s} \pm 5\%$ until breakdown occurs as indicated by operation of the circuit-interrupting equipment; record the highest rms voltage value that occurred immediately prior to each breakdown. Occasional momentary discharges may occur which do not result in operation of the interrupting equipment; these shall be disregarded until the voltage across the specimen collapses to less than 100 V. Conduct four additional breakdowns waiting at least 60 s but no more than 90 s before applications of voltage for successive breakdowns. (During the intervals before voltage application, between breakdowns, and at the time voltage is being applied, the propeller shall be circulating the oil.)

9.4 Calculate the mean and standard deviation of the five breakdowns as follows:

$$\bar{x} = \frac{1}{5} \sum_{i=1}^5 X_i \quad \text{and} \quad s = \sqrt{\frac{1}{4} \left[\sum_{i=1}^5 X_i^2 - 5\bar{x}^2 \right]}$$

where:

\bar{X}_i = mean of the five individual values,
 X_i = i th breakdown voltage, and
 s = standard deviation.

9.5 Evaluate

9.5 Using the results to ensure breakdown voltage values determined in 9.4, determine that the percent coefficient range of variance $((s/\bar{X}) \times 100)$ the five (5) breakdown voltages does not exceed 10 %, and that the range (maximum minus minimum) values indicated as follows:

1 mm gap setting	Range must be less than 120 % of the individual tests comprised of five breakdowns shall not exceed 86 % (5) breakdown voltages
1 mm gap setting	Range must be less than 120 % of the mean of the five (5) breakdown voltages
2 mm gap setting	Range must be less than 92 % of the mean (\bar{X}), if of the five (5) breakdown voltages
2 mm gap setting	Range must be less than 92 % of the mean of the five (5) breakdown voltages

If this criteria range is not met then exceeded, the test should tests must be repeated.

9.6 When it is desired merely to determine if the dielectric strength is above or below a specified level, only five breakdowns are required, provided the five values are all above or all below this level. Otherwise, follow the procedure described in 9.4

10. Report

10.1 Include in the report the following:

- 10.1.1 The test method used,
- 10.1.2 The volts (rms value) at each breakdown, and the mean of all breakdowns reported to two significant digits,
- 10.1.3 The approximate temperature of the oil at the time of the test, and
- 10.1.4 The electrode spacing.

11. Precision and Bias ⁵

11.1 *Single-Operator Precision*—The single operator percent coefficient of variance (in %), of each a single test result comprised of five 5 breakdowns must not exceed 10 %. The range of each individual test comprised of five breakdowns shall not exceed 86 % of has been found for the mean (\bar{X}). If two or more tests on 1 mm gap to be 14 % and for the same sample are 2 mm gap 11 %. Therefore, results of two properly conducted tests by the same operator, on the test results shall same sample should not differ by more than 28 % of 40 % and 30 % respectively. The maximum allowable range for the average series of 5 breakdowns should not exceed 120 % for the two tests being compared. This is a temporary repeatability statement based on prior use of a coefficient of variance of 10 %. Testing is planned to replace 1 mm gap and 92 % for the precision statement before 2007. 2 mm gap.

11.2 *Multilaboratory Precision*—The multilaboratory percent coefficient of variance has been found for the 1 mm gap to be 17 % and for the 2 mm gap 14 %. Therefore, two separate test results conducted by separate laboratories on the same sample of oil should not differ by more than 47 % of the mean of the two tests if the 1 mm gap was used or differs by more than 40 % of the mean of the two tests if the 2 mm gap was used. The precision statement for the 1 mm gap is temporary, because sufficient laboratories were not available and testing is planned to replace the precision statement before 2009.

11.3 *Bias*—No statement can be made about the bias of this test method because a standard reference material is not available.

12. Keywords

12.1 breakdown voltage; dielectric strength; insulating oils; test cell; VDE electrodes

⁵ Supporting data is available from ASTM International Headquarters. Request RR:D27-1014.

APPENDIX**(Nonmandatory Information)****X1. FACTORS THAT AFFECT THE DIELECTRIC BREAKDOWN VOLTAGE OF INSULATING LIQUIDS AT COMMERCIAL POWER FREQUENCIES**

X1.1 The dielectric breakdown voltage of a liquid at commercial power frequencies is also affected by:

X1.1.1 The degree of uniformity of the electric field,

X1.1.2 The area of the electrodes,

X1.1.3 Volume of the liquid under maximum stress,

X1.1.4 Insulation on the electrodes,

X1.1.5 Water content of the oil,

X1.1.6 Size and number of particles in the oil,

X1.1.7 Length of time for which the liquid is under stress,

X1.1.8 The temperature of the liquid as it affects the relative saturation level of moisture in solution,

X1.1.9 Gassing tendencies of the liquid under the influence of electric stress,

X1.1.10 Concentration of dissolved gases if saturation levels are exceeded as a result of a sudden cooling or decrease in pressure, which may cause the formation of gas bubbles,

X1.1.11 Incompatibility with materials of construction, and

X1.1.12 Velocity of flow.

X1.1.13 A decrease in dielectric strength of the liquid can have an accentuated effect on the electric creepage strength of the solid insulating materials immersed in the liquid.

X1.2 Because of the separate, cumulative, and in some cases, interacting effects of the influences listed above, the average breakdown voltage of a liquid as determined by this test method cannot be used directly for design purposes. Procedures utilizing electrode shapes and configurations similar to those used in oil filled apparatus are used to determine design data and to study the influence of the variables. However, test results utilizing the rounded electrodes in this test method do give an indication of the relative dielectric strength of the oil in the insulation system.

ASTM International takes no position respecting the validity of any patent rights asserted in connection with any item mentioned in this standard. Users of this standard are expressly advised that determination of the validity of any such patent rights, and the risk of infringement of such rights, are entirely their own responsibility.

This standard is subject to revision at any time by the responsible technical committee and must be reviewed every five years and if not revised, either reapproved or withdrawn. Your comments are invited either for revision of this standard or for additional standards and should be addressed to ASTM International Headquarters. Your comments will receive careful consideration at a meeting of the responsible technical committee, which you may attend. If you feel that your comments have not received a fair hearing you should make your views known to the ASTM Committee on Standards, at the address shown below.

This standard is copyrighted by ASTM International, 100 Barr Harbor Drive, PO Box C700, West Conshohocken, PA 19428-2959, United States. Individual reprints (single or multiple copies) of this standard may be obtained by contacting ASTM at the above address or at 610-832-9585 (phone), 610-832-9555 (fax), or service@astm.org (e-mail); or through the ASTM website (www.astm.org).