

This document is not an ASTM standard and is intended only to provide the user of an ASTM standard an indication of what changes have been made to the previous version. Because it may not be technically possible to adequately depict all changes accurately, ASTM recommends that users consult prior editions as appropriate. In all cases only the current version of the standard as published by ASTM is to be considered the official document.



Designation: F 1825 – 97^{€1}



Designation: F 1825 – 03

Standard Specification for Fixed Length Clampstick Clampstick Type Live Line Tools¹

This standard is issued under the fixed designation F 1825; the number immediately following the designation indicates the year of original adoption or, in the case of revision, the year of last revision. A number in parentheses indicates the year of last reapproval. A superscript epsilon (ϵ) indicates an editorial change since the last revision or reapproval.

~~^{ε1} Note—Editorial corrections were made in February 1999.~~

¹ This specification is under the jurisdiction of ASTM Committee F18 on Electrical Protective Equipment for Workers and is the direct responsibility of Subcommittee F18.35 on Tools and Equipment.

Current edition approved Oct. 10, 1997; 2003. Published February 1998; May 2003.

1. Scope

1.1 This specification applies to the Clampstick type live line tools to ensure manufacturing processes and materials are compatible and no deterioration of components occur during the assembly process.

1.2 This specification establishes the technical characteristics for clampsticks.

1.3 This specification applies ~~only to one piece fixed length clampsticks both hollow and foam filled. It does not apply to folding, sectional, or telescopic type clampsticks. foam-filled.~~

1.4 The values stated in SI units are to be regarded as the standard. The values given in parentheses are for information only.

1.5 The following safety hazards caveat pertains only to the test portions of this specification: *This standard does not purport to address all of the safety concerns, if any, associated with its use. It is the responsibility of the user of this standard to establish appropriate safety and health practices and determine the applicable of regulatory limitations prior to use.*

1.6 The use, maintenance, and in-service testing of this equipment is beyond the scope of this specification.

2. Referenced Documents

2.1 *ASTM Standards:*

~~D 149 Test Method for Dielectric Breakdown Voltage and Dielectric Strength of Solid Electrical Insulating Materials at Commercial Power Frequencies²~~
~~D 695 Test Method for Compressive Properties of Rigid Plastics³~~
F 711 Specification for Fiberglass-Reinforced Plastic (FRP) Rod and Tube Used in Live Line Tools²
~~F 819 Definitions of Terms 819 Terminology Relating to Electrical Protective Equipment for Workers~~
~~2.2 IEC Standard:~~
~~IEC 832 Insulating Poles (Insulating Sticks) and Universal Tool Attachments (Fittings) for Live Working³²~~

3. Terminology

3.1 *Definitions*— Terminology used in this specification is in accordance with ~~Definitions Terminology~~ F 819.

3.2 *Definitions of Terms Specific to This Standard:*

3.2.1 *clampstick, n*—a live line tool having a hand control with latching stops at the butt end mechanically connected by an insulating rod to a hook that retracts into a slotted ferrule at the head end.

3.2.1.1 *Discussion*—Clampsticks are used by qualified workers for high-voltage application of hot line clamps, ground clamps, operation of energized apparatus and the like. Clampsticks are sometimes referred to as “shotgun sticks” or “grip all sticks”. Clampsticks ~~shall~~ are designed to provide insulation to the user while performing the above operations.

3.2.2 *design test, n*—a test made on a sample treated as representative of an industrial product. This test will not generally be repeated in quantity production.

3.2.3 *electrical test, n*—a test to ensure that a product meets minimum electrical requirements of a standard.

3.2.4 *FRP insulating tubes and rods, n*— fiberglass reinforced plastic (FRP) products manufactured so that the tubes and rods produced will meet the electrical and mechanical requirements of this specification.

3.2.5 *hand control, n*—lower control of the clampstick and connected to hook by an FRP rod.

3.2.6 *head ferrule, n*—a nonmetallic structural part with slots to accept clamp bases of standard size and allow the closing motion of the hook.

3.2.7 *mechanical test, n*—a test to ensure that a product meets minimum mechanical requirements of a standard.

■ ² *Annual Book of ASTM Standards, Vol 10.01*3.

3.2.8 *rear stop, n*—a device or devices that stop the rearward motion of the hand control when the tool has reached its fully retracted position.

3.2.9 *retract lock, n*—a locking means that allows the hand control to be positioned and releaseably latched between the safety stop and rear stop and prevents movement toward the safety stop.

3.2.10 *safety stop, n*—a releasable latch that automatically and positively engages at partial retract to fully capture a device.

3.2.11 *visual inspection, n*—a visual check made to detect defects that impede the performance of product(s).

4. Materials and Manufacture

4.1 Neither the FRP tube and rod, foam filling, or the bonding adhesive shall deteriorate during the prescribed mechanical and electrical test of this specification.

4.2 The external surface of the FRP shall be uniform, symmetrical, and free of abrasions, scratches, blemishes, and surface defects.

4.3 Any defect that may capture an impurity or impair the dielectric integrity of the product shall be cause for rejection.

4.4 FRP rod or tube material to which a finish coating, such as paint, is applied must meet all physical, electrical, and mechanical requirements after the coating is applied.

4.5 The external surfaces of all composite material parts and fittings shall be uniform and free of projections or flaws that present a hazard to the operator.

4.6 Moving parts must operate properly without binding at temperatures from -40°C (-40°F) to 48.9°C (120°F).

4.7 Retract lock and safety stop must be separate and ~~be arranged so~~ arranged that release of retract lock or forward motion of control shall not release safety stop. Release of safety stop must require a distinct and separate action.

4.8 The hook shall be designed to enter a 1.42-cm (0.560-in.) inside diameter, minimum eye. The ferrule shall be designed to swallow an eye with a 3.96-cm (1.560-in.) outside diameter and a 1.19-cm (0.470-in.) maximum diameter cross-section and with a 2.29 cm (0.900-in.) outside diameter maximum shank or flange.

4.9 Hook opening shall accept a 20-mm ($\frac{3}{4}$ -in.) diameter rod.

4.10 Hook retraction from safety stop (intermediate position) shall be 11.73 cm (4.62 in.) minimum.

4.11 The end slots of head ferrule must accept a clamp base 1.22 cm (0.480 in.) max width; to a depth of 0.76 cm (0.300 in.) min.

4.12 Foam-filled clampsticks shall be sealed at both ends.

4.13 Foam-filled FRP tube and solid FRP rod used in the manufacturing of clampsticks shall meet all requirements of Specification F 711.

4.14 Hollow tube shall meet all requirements of Specification F 711 ~~except that it~~ mechanical aging and shall withstand ~~90 %~~ 75 % crushing strength of the foam-filled tube of equal outside diameter listed in Specification F 711.

5. Mechanical Design Test

5.1 FRP tube and rod shall meet all mechanical specifications and requirements of Specification F 711.

5.2 The complete clampstick shall withstand a torque load of 50 ft lb along centerline of operating parts rotated about longitudinal axis without failure.

5.2.1 Sectional (jointed) clampsticks shall be tested assembled (spliced together) and folded clampsticks shall be tested fully unfolded. Telescoping clampsticks shall be tested fully extended.

5.3 Safety stop shall withstand a tensile load of 750 lb without failure.

5.4 At each position, the retract lock shall withstand a tensile load of 750 lb without failure.

5.5 Control rod assembly shall withstand a tensile load of 750 lb without failure.

5.6 The mechanical design test shall be performed on a minimum of three samples. ~~Note 1—IEC 832 requires 1.25 T_n applied at 2 N.m/s and held for one minute, then increased to 2.5 T_n without failure, where T_n is equal to the manufacturer's rating.~~

6. Electrical Design Test

6.1 *Electrical Design Test Procedure* :

6.1.1 The test apparatus shall be designed to provide the operator full protection in the performance of his duties and provide reliable means of de-energizing and grounding the high-voltage circuit. Isolate the test equipment and specimen to guard against accidental contact by persons in the vicinity.

~~6.1.2 Ensure that the~~

6.1.2 The ambient temperature for the test location is shall not be lower than 15.55°C (60°F).

6.1.3 Electrically test the three samples of clampsticks wet using 60-hz AC. Hz ac. Test the entire insulating length of the clampstick at 304.8-mm (12-in.) segments.

6.1.3.1 Sectional (jointed) clampsticks shall be tested assembled (spliced together) and folded clampsticks shall be tested fully unfolded. The segment that contains the hinge on the folding clampstick and the splice joint on the sectional clampstick shall be considered non-insulating (see Fig. 1). The joint segment shall not flash or cause deterioration to other segments. The guarded circuit shall not be in contact with any metal components.

6.1.3.2 Telescoping clampsticks shall be tested fully extended.

6.1.3.3 The untested section shall be distinctly marked if not visible.

6.1.4 Ensure that the test contacts (electrode) are of any conductive material that will provide contact around the circumference of the test specimen.

6.1.5 Suspend the clampstick in a horizontal position at least 0.9 m (3 ft) above the floor using insulating supports. If the clampstick design requires operating rod guides, the guides shall be in place on the clampstick during the electrical test. The external operating rod clampstick should be mounted with the operating rod 90° from the vertical.

6.1.6 Wrap the guarded (shielded) electrode around the clampstick so contact is maintained on the entire circumference of the clampstick. In the case of an external operating rod, wrap the guarded (shielded) pickup electrode around the operating rod and the tube while trying to maintain as much surface contact as possible (see Fig. 1). ~~Ensure that the 2). The electrode does~~ shall not cause the operating rod to rest against the tube.

6.1.7 Attach the meter leads to the pickup electrode. Attach the guard (shield) to the ground lug on the test set. The measuring equipment should not be placed within 1.83 m (6 ft) of the high-voltage electrode. Shield and ground the assembly of connection for the measuring equipment. Use shielded cable, RG-58, or similar for the meter lead. Attach center conductor of the shielded cable to the pickup electrode and to the ground return meter of the test set. Strip back 50.8 mm (2 in.) of the shield and float the shield on the pickup electrode end and attach the shield to the ground lug on the test set.

6.1.8 Spray the test segment with distilled water to thoroughly wet its surface. Conductivity of the water should be 3.0 micromhos/cm or less. A clean spray applicator, adjusted to a fine mist, is suitable for this purpose. Spray water uniformly on the clampstick until droplets just begin to roll down the surface of the clampstick. Water should be sprayed perpendicular to the surface (axis) of the clampstick. Avoid spraying water under the operating rod guides and hand guard, avoid bridging the gap between the operating rod and the tube, and avoid bridging the insulation between the pickup electrode and guard (shield). For clampsticks with internal operating rods, spray the interior area also with distilled water.

NOTE 21—Make sure the internal rod is sufficiently wet.

6.1.8.1 As an alternate method of wetting internal operating rod clampsticks, the sticks may be submerged in water then positioned at a 30° angle with end cap removed for 2 min to allow water to run out.

6.1.9 Apply potential to each test segment within a time frame of 5 to 15 min after wetting. Increase the voltage gradually (3000 V/s) to 75 KVAC (60 Hz) and maintain for 1 min.

6.1.10 Measure and record the maximum leakage current in the ground return meter. A leakage in excess of 75 µa per segment signifies a failure.

6.1.11 During the course of the testing, there shall be no sign of flashover, tracking or puncture on any of the clampsticks. The clampstick will be rejected for a failure of any test segment.

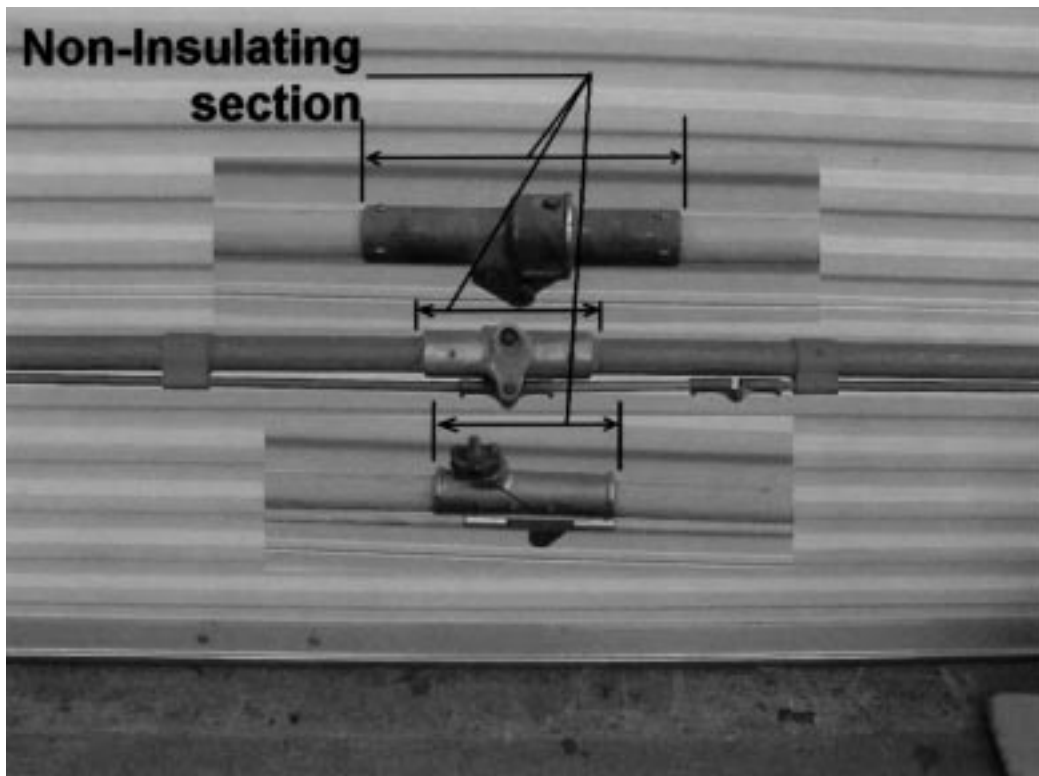

FIG. 1 View of Hinge Joint of Folding Internal and External Operating Rod Clampsticks

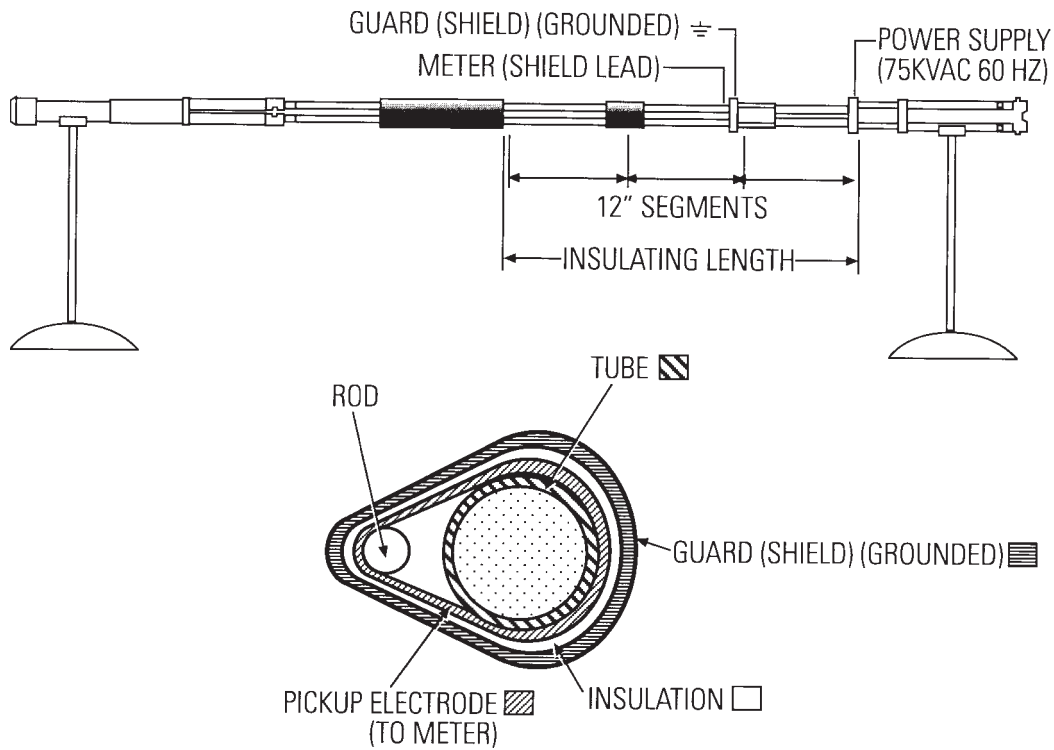

FIG. 2 Test Set-up Example

6.2 The electrical design test shall be performed on a minimum of three samples.

7. Precision and Bias

7.1 *Precision*—The precision of the results is a function of the procedures, facilities utilized, as well as compliance to the recommended industry state-of-the-art practices. Reproducible analysis determinations by different users can be achieved only with identical facilities and trained conscientious personnel.

7.2 The test equipment shall be of such a quality that the applied voltage shall be within $\pm 4\%$ of the specified test voltage.

7.3 The current-measuring device shall be of such a quality that the current measured shall be accurate to within $\pm 3\%$ of full scale. The meter scale shall not be greater than 100 μa .

8. Keywords

8.1 clampstick; gripall stick; shotgun stick

ASTM International takes no position respecting the validity of any patent rights asserted in connection with any item mentioned in this standard. Users of this standard are expressly advised that determination of the validity of any such patent rights, and the risk of infringement of such rights, are entirely their own responsibility.

This standard is subject to revision at any time by the responsible technical committee and must be reviewed every five years and if not revised, either reapproved or withdrawn. Your comments are invited either for revision of this standard or for additional standards and should be addressed to ASTM International Headquarters. Your comments will receive careful consideration at a meeting of the responsible technical committee, which you may attend. If you feel that your comments have not received a fair hearing you should make your views known to the ASTM Committee on Standards, at the address shown below.

This standard is copyrighted by ASTM International, 100 Barr Harbor Drive, PO Box C700, West Conshohocken, PA 19428-2959, United States. Individual reprints (single or multiple copies) of this standard may be obtained by contacting ASTM at the above address or at 610-832-9585 (phone), 610-832-9555 (fax), or service@astm.org (e-mail); or through the ASTM website (www.astm.org).