



Standard Practice for Contact Closure Cycling of a Membrane Switch¹

This standard is issued under the fixed designation F 1578; the number immediately following the designation indicates the year of original adoption or, in the case of revision, the year of last revision. A number in parentheses indicates the year of last reapproval. A superscript epsilon (ϵ) indicates an editorial change since the last revision or reapproval.

1. Scope

1.1 This practice covers the setup, procedure, and apparatus required to depress and release a membrane switch to a predetermined number of cycles.

1.2 This practice also covers the optional use of specified voltage and current during the cycling of the membrane switch.

1.3 *This standard does not purport to address all of the safety concerns, if any, associated with its use. It is the responsibility of the user of this standard to establish appropriate safety and health practices and determine the applicability of regulatory limitations prior to use.*

2. Referenced Documents

2.1 *ASTM Standards:*²

D 2240 Test Method for Rubber Property—Durometer Hardness

F 1597 Test Method for Determining the Actuation Force and Contact Force of a Membrane Switch

3. Terminology

3.1 *Definitions:*

3.1.1 *actuation force*—the maximum force measured prior to or including the point at which contact closure is achieved on a membrane switch.

3.1.2 *contact closure*—the event at which a specified resistance is achieved.

3.1.3 *contact force*—the force at contact closure.

3.1.4 *duration*—the number of depressions and release cycles.

3.1.5 *duty cycle*—the ratio of switch closed time to total cycle time.

3.1.6 *specified resistance*—maximum allowable resistance as measured between two terminations whose internal switch contacts are held closed to complete a circuit.

3.1.7 *test rate*—the number of depressions and release cycles per second.

3.1.8 *membrane switch*—a momentary switching device in which at least one contact is on, or made of, a flexible substrate.

4. Significance and Use

4.1 Contact closure cycling is useful to manufacturers and users for determining the effect of repeated closing of switch contacts or the effect of repeated flexure of other switch components.

4.2 The characteristic(s) are measured before cycling begins and then again after cycling ends.

5. Apparatus

5.1 *Suitable Electronic Monitoring Device*, to detect and count contact closure at a specified test rate and duty cycle.

5.2 *Surface*, flat, smooth, unyielding, and larger than the switch.

5.3 *Test Probes*, built to either of the configurations shown in Fig. 1 or Fig. 2, are acceptable but must be made of an inert elastomeric material with a hardness number equivalent to A/45 \pm 5 as measured in accordance with Test Method D 2240. Test probes that do not meet this criteria must be specified and recorded fully.

5.4 *Device*, which will cycle the probe repeatedly into and away from the switch at a specified test rate and duty cycle, and which is capable of providing means for counting probe cycles. The motion of the probe should be perpendicular to the plane of the switch.

5.5 *Power Supply*, capable of supplying specified voltage or current, or both, if required.

6. Procedure

6.1 *Pretest Setup:*

6.1.1 Secure the switch on a test table.

6.1.2 Measure the desired characteristics of the switch so that comparable measurements can be made during or after the test.

6.1.2.1 Document the procedure and test equipment used to measure the characteristics.

6.1.3 Determine the actuation force (F_a). (See Test Method F 1597.)

6.1.4 Position the test probe over the desired area of the switch.

¹ This practice is under the jurisdiction of ASTM Committee F01 on Electronics and is the direct responsibility of Subcommittee F01.18 on Membrane Switches.

Current edition approved June 10, 2001. Published August 2001. Originally published as F 1578 – 95. Last previous edition F 1578 – 00.

² For referenced ASTM standards, visit the ASTM website, www.astm.org, or contact ASTM Customer Service at service@astm.org. For *Annual Book of ASTM Standards* volume information, refer to the standard's Document Summary page on the ASTM website.

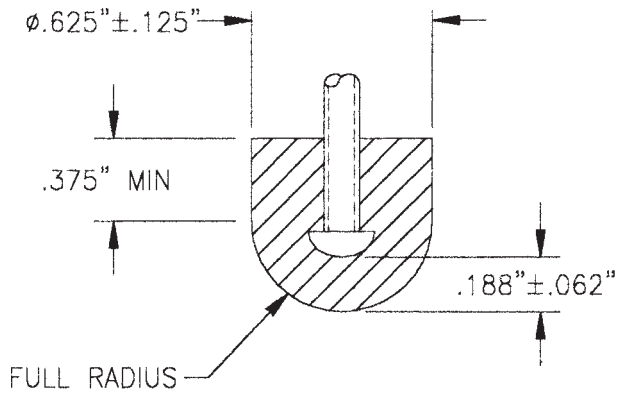

FIG. 1 Test Probe Option

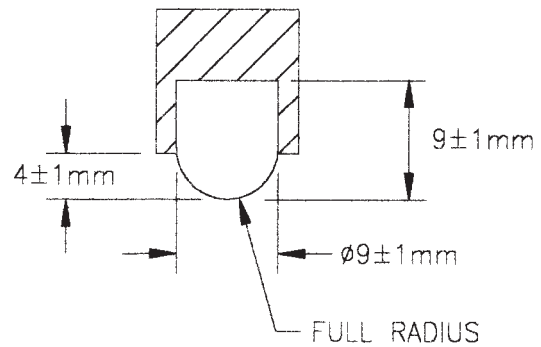

FIG. 2 Test Probe Option

NOTE 1—If switch removal from the test table is necessary, return the switch to the exact location.

6.3 End test:

6.3.1 Stop the test at a preselected duration or at the point of failure.

6.3.2 Measure the final characteristics using the same method, equipment, and conditions as used in the pretest setup described in 6.1.2.

7. Keywords

7.1 contact closure cycling; membrane switch

6.1.5 Connect the switch terminations to the contact closure monitoring device, and power supply, if applicable.

6.1.6 Adjust the probe in the full-down position to achieve 110 % of actuation force (Fa) or to a specified force.

6.1.7 Set the power supply voltage or current, or both, to the specified values, if applicable.

6.2 In-Process Test:

6.2.1 Begin cycling at specified test rate and duty cycle.

6.2.2 Measure the characteristics of the switch at desired intervals as performed in 6.1.2.

ASTM International takes no position respecting the validity of any patent rights asserted in connection with any item mentioned in this standard. Users of this standard are expressly advised that determination of the validity of any such patent rights, and the risk of infringement of such rights, are entirely their own responsibility.

This standard is subject to revision at any time by the responsible technical committee and must be reviewed every five years and if not revised, either reapproved or withdrawn. Your comments are invited either for revision of this standard or for additional standards and should be addressed to ASTM International Headquarters. Your comments will receive careful consideration at a meeting of the responsible technical committee, which you may attend. If you feel that your comments have not received a fair hearing you should make your views known to the ASTM Committee on Standards, at the address shown below.

This standard is copyrighted by ASTM International, 100 Barr Harbor Drive, PO Box C700, West Conshohocken, PA 19428-2959, United States. Individual reprints (single or multiple copies) of this standard may be obtained by contacting ASTM at the above address or at 610-832-9585 (phone), 610-832-9555 (fax), or service@astm.org (e-mail); or through the ASTM website (www.astm.org).