



Designation: F 1597 – 002

Standard Test Method for Determining the Actuation Force and Contact Force of a Membrane Switch ¹

This standard is issued under the fixed designation F 1597; the number immediately following the designation indicates the year of original adoption or, in the case of revision, the year of last revision. A number in parentheses indicates the year of last reapproval. A superscript epsilon (ε) indicates an editorial change since the last revision or reapproval.

1. Scope

1.1 This test method covers the measurement of actuation force or contact force, or both, of a membrane switch utilizing a pre-determined resistance value.

1.2 *This standard does not purport to address all of the safety concerns, if any, associated with its use. It is the responsibility of the user of this standard to establish appropriate safety and health practices and determine the applicability of regulatory limitations prior to use.*

¹ This test method is under the jurisdiction of ASTM Committee F01 on Electronics and is the direct responsibility of Subcommittee F01.18 on Membrane Switches. Current edition approved ~~Dec. 20, 2000~~; May 10, 2002. Published ~~February 2001~~; July 2002. Originally published as F 1597-95. Last previous edition F 1597-9501.

2. Referenced Documents

- 2.1 *ASTM Standards:*²
 - D 2240 Test Method for Rubber Property-Durometer Hardness
 - F 1570 Test Method for Determining the Tactile Ratio of a Membrane Switch

3. Terminology

3.1 *Definitions:*

- 3.1.1 *actuation force (Fa)*—the maximum force measure prior to or including point at which contact closure is achieved on a membrane switch.
- 3.1.2 *contact closure (make)*—the event at which a specified resistance is achieved.
- 3.1.3 *contact force (Fc)*—the force at contact closure.
- 3.1.4 *membrane switch*—a momentary switching device in which at least one contact is on, or made of, a flexible substrate.
- 3.1.5 *non-tactile switch*—a switch assembly that has a tactile ratio equal to zero (see Test Method F 1570).
- 3.1.6 *specified resistance*—maximum allowable resistance as measured between two terminations whose internal switch contacts, when contacts are held closed; to complete a circuit.
- 3.1.7 *tactile switch*—a switch assembly that provides a tactile ratio greater than zero (see Test Method F 1570).

4. Significance and Use

- 4.1 Specified resistance is useful to manufacturers and users when designing membrane switch interface circuitry.
- 4.2 Actuation force and contact force are useful to manufacturers and users in determining the suitability, preference and aesthetics of a membrane switch in a given application.

5. Apparatus

5.1 *Test Probe*—Test probes that do not meet the following criteria must be fully specified and recorded. Do not change probe type throughout the duration of the test.

Switch to be measured	Material	Size and Shape
Tactile switch Tactile switch	Non-elastic Metal or non-elastic	To be specified Flat tip 25 to 50 % of tactile element diameter recommended. See Fig. 1, Fig. 1 or Fig. 2 or specified
Non-tactile switch	Inert elastomeric material Hardness = A/45 ± 5 per Test Method D-2240	Fig. 2 or Fig. 3 or specified
Non-tactile switch	Inert elastomeric material Hardness = A/45 ± 5 per Test Method D 2240	Fig. 2 or Fig. 3 or specified

- 5.2 *Test Surface*, flat, smooth, unyielding and larger than switch under test.
- 5.3 *Device*, to hold test probe securely and provide perpendicular movement into and away from switch under test.
- 5.4 *Resistance Measuring Device*, that is, ~~Ohm~~ ohm meter. The device should not apply a voltage outside the operating range of the switch contacts.

² For referenced ASTM standards, visit the ASTM website, www.astm.org, or contact ASTM Customer Service at service@astm.org. For *Annual Book of ASTM Standards*, Vol. 09.01, volume information, refer to the standard's Document Summary page on the ASTM website.

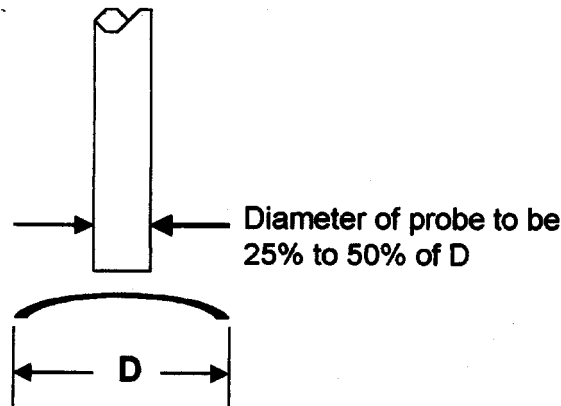

FIG. 1 Test Probe Option

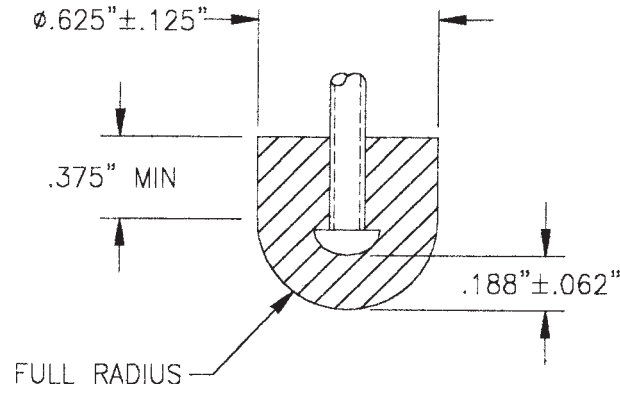

FIG. 2 Test Probe Option

5.5 Suitable Monitoring Device , to measure force on test probe.

6. Procedure

6.1 Pre-Test Setup:

- 6.1.1 Secure switch on test surface.
- 6.1.1.1 Precondition switch by depressing manually 25 times.
- 6.1.2 Position test probe over desired area of switch.
- 6.1.3 Lower probe until tip is just above top surface of switch without touching.
- 6.1.4 Connect switch terminals to resistance measuring device (see Fig. 3.4).

6.2 In-Process Test:

- 6.2.1 Begin by activating test probe movement down at a rate not to exceed 13 mm/s.
- 6.2.2 Monitor force and resistance during probe movement.
- 6.2.3 When specified resistance is achieved, record force on probe as contact force (F_c).
- 6.2.3.1 Stop downward movement of test probe.
- 6.2.4 Record maximum force on probe seen during probe movement as actuation force (F_a). This value can be greater than or equal to F_c .
- 6.2.5 Retract test probe to the same position as 6.1.3.
- 6.2.6 Repeat 6.2.1-6.2.5 ~~thru~~ four more times.

7. Calculations

- 7.1 Determine the averages of five readings and record as F_c and F_a .

8. Report

- 8.1 Report the following information:
 - 8.1.1 Temperature,
 - 8.1.2 Humidity,
 - 8.1.3 Barometric Pressure,
 - 8.1.4 Test probe shape and durometer,
 - 8.1.5 Actuation force (F_a) (may equal contact force),
 - 8.1.6 Contact force (F_c),

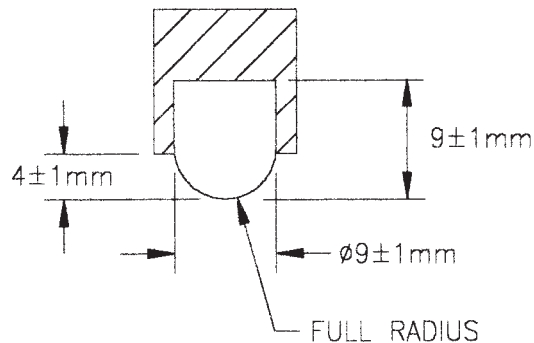

FIG. 3 Test Probe Option

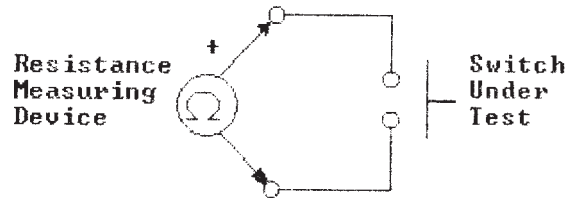

FIG. 4 Resistance Measuring Device Connection to Switch Under Test

- 8.1.7 Specified resistance,
- 8.1.8 Description of probe holding fixture and monitoring device,
- 8.1.9 Part number or description of switch, or both, and
- 8.1.10 Date of test.

9. Precision and Bias

9.1 The precision and bias of this test method are under investigation.

10. Keywords

10.1 actuation force; contact force; membrane switch

ASTM International takes no position respecting the validity of any patent rights asserted in connection with any item mentioned in this standard. Users of this standard are expressly advised that determination of the validity of any such patent rights, and the risk of infringement of such rights, are entirely their own responsibility.

This standard is subject to revision at any time by the responsible technical committee and must be reviewed every five years and if not revised, either reapproved or withdrawn. Your comments are invited either for revision of this standard or for additional standards and should be addressed to ASTM International Headquarters. Your comments will receive careful consideration at a meeting of the responsible technical committee, which you may attend. If you feel that your comments have not received a fair hearing you should make your views known to the ASTM Committee on Standards, at the address shown below.

This standard is copyrighted by ASTM International, 100 Barr Harbor Drive, PO Box C700, West Conshohocken, PA 19428-2959, United States. Individual reprints (single or multiple copies) of this standard may be obtained by contacting ASTM at the above address or at 610-832-9585 (phone), 610-832-9555 (fax), or service@astm.org (e-mail); or through the ASTM website (www.astm.org).