



Standard Practice for Measuring Sheet Resistance of Thin Film Conductors for Flat Panel Display Manufacturing Using a Four-Point Probe Method¹

This standard is issued under the fixed designation F 1711; the number immediately following the designation indicates the year of original adoption or, in the case of revision, the year of last revision. A number in parentheses indicates the year of last reapproval. A superscript epsilon (ϵ) indicates an editorial change since the last revision or reapproval.

1. Scope

1.1 This practice describes methods for measuring the sheet electrical resistance of sputtered thin conductive films deposited on large insulating substrates, used in making flat panel information displays. It is assumed that the thickness of the conductive thin film is much thinner than the spacing of the contact probes used to measure the sheet resistance.

1.2 This standard is intended to be used with Test Method F 390.

1.3 Sheet resistivity in the range 0.5 to 5000 ohms per square may be measured by this practice. The sheet resistance is assumed uniform in the area being probed.

1.4 This practice is applicable to flat surfaces only.

1.5 Probe pin spacings of 1.5 mm to 5.0 mm, inclusive (0.059 to 0.197 in. inclusive) are covered by this practice.

1.6 The method in this practice is potentially destructive to the thin film in the immediate area in which the measurement is made. Areas tested should thus be characteristic of the functional part of the substrate, but should be remote from critical active regions. The method is suitable for characterizing dummy test substrates processed at the same time as substrates of interest.

1.7 The values stated in SI units are to be regarded as the standard. The values given in parentheses are for information only.

1.8 *This standard does not purport to address all of the safety concerns, if any, associated with its use. It is the responsibility of the user of this standard to establish appropriate safety and health practices and determine the applicability of regulatory limitations prior to use.*

2. Referenced Documents

2.1 ASTM Standards:

F 390 Test Method for Sheet Resistance of Thin Metallic Films With a Collinear Four-Probe Array²

3. Terminology

3.1 Definitions:

¹ This practice is under the jurisdiction of ASTM Committee F-1 on Electronics and is the direct responsibility of Subcommittee F01.17 on Sputtered Thin Films.

Current edition approved June 10, 1996. Published August 1996.

² *Annual Book of ASTM Standards*, Vol 10.04.

3.1.1 For definitions of terms used in this practice see Test Method F 390.

4. Summary of Practice

4.1 This practice describes the preferred means of applying Test Method F 390 to measure the electrical sheet resistance of thin films on very large flat substrates. An array of four pointed probes is placed in contact with the film of interest. A measured electrical current is passed between two of the probes, and the electrical potential difference between the remaining two probes is determined. The sheet resistance is calculated from the measured current and potential values using correction factors associated with the probe geometry and the probe's distance from the test specimen's boundaries.

4.2 The method of F390 is extended to cover staggered in-line and square probe arrays. In all the designs, however, the probe spacings are nominally equal.

4.3 This practice includes a special electrical test for verifying the proper functioning of the potential measuring instrument (voltmeter), directions for making and using sheet resistance reference films, an estimation of measurement error caused by probe wobble in the probe supporting fixture, and a protocol for reporting film uniformity.

4.4 Two appendices indicate the computation methods employed in deriving numerical relationships and correction factors employed in this practice, and in Test Method F 390.

5. Significance and Use

5.1 Applying Test Method F 390 to large flat panel substrates presents a number of serious difficulties not anticipated in the development of that standard. The following problems are encountered.

5.1.1 The four-point probe method may be destructive to the thin film being measured. Sampling should therefore be taken close to an edge or corner of the plate, where the film is expendable. Special geometrical correction factors are then required to derive the true sheet resistance.

5.1.2 Test Method F 390 is limited to a conventional collinear probe arrangement, but a staggered collinear and square arrays are useful in particular circumstances. Correction factors are needed to account for nonconventional probe arrangements.

5.1.3 Test Method F 390 anticipates a precision testing

arrangement in which the probe mount and sample are rigidly positioned. There is no corresponding apparatus available for testing large glass or plastic substrates. Indeed, it is common in flat panel display making that the probe is hand held by the operator.

5.1.4 It is difficult, given the conditions cited in 5.1.3, to ensure that uniform probe spacing is not degraded by rough handling of the equipment. The phased square array, described, averages out probe placement errors.

5.1.5 This practice is estimated to be precise to the following levels. Otherwise acceptable precision may be degraded by probe wobble, however (see 8.6.4).

5.1.5.1 As a referee method, in which the probe and measuring apparatus are checked and qualified before use by the procedures of Test Method F 390 paragraph 7 and this practice, paragraph 8:

standard deviation, s , from measured sheet resistance, R_S , is $\leq 0.01 R_S$

5.1.5.2 As a routine method, with periodic qualifications of probe and measuring apparatus by the procedures of Test Method F 390 paragraph 7 and this practice, paragraph 8:

standard deviation, s , from measured sheet resistance, R_S , is $\leq 0.02 R_S$

6. Apparatus

6.1 Probe Assembly:

6.1.1 The probe assembly must meet the apparatus requirements of F 390, 5.1.1-5.1.3.

6.1.2 Four arrangements of probe tips are covered in this practice:

6.1.2.1 *In-Line, Collinear, Probe Tips*, with current flowing between the outer two probes (see Fig. 1A). This is the conventional arrangement specified in Test Method F 390.

6.1.2.2 *Staggered Collinear Probe Tips*, with current flowing between one outer and one interior probe (see Fig. 1B). This arrangement is sometimes used as a check to verify the results of a conventional collinear measurement (see 6.1.2.1).

6.1.2.3 *Square Array*, with current conducted between two adjacent probe tips (see Fig. 1C).

6.1.2.4 *Phased Square Array*, with current applied alternately between opposite pairs of tips (see Fig. 1D). This arrangement has the advantage of averaging out errors caused by unequal probe spacing.

6.1.3 *Probe Support*— The probe support shall be designed in such a manner that the operator can accurately lower the probes perpendicularly onto the surface and provide a reproducible probe force for each measurement. Spring loading or gravity probe pin loading are acceptable.

6.2 *Electrical Measuring Apparatus*— The electrical apparatus must meet the apparatus requirements of Test Method F 390, 5.2.1 through 5.2.4.

6.3 *Specimen Support*— The substrate to be tested must be supported firmly.

6.4 Additional Apparatus:

6.4.1 If measurements will be made within a distance of 20 times the probe spacing from an insulating or highly conductive edge or corner ($20 \times S_i$, where $i = 1, 2, 3,$ or 4 , with reference to Fig. 1), an instrument capable of measuring the distance from the probe array position to the insulating or

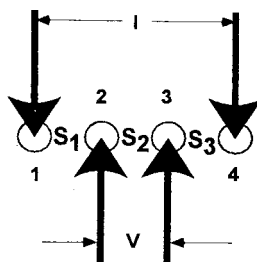

FIG. 1A
Colinear Probe Array

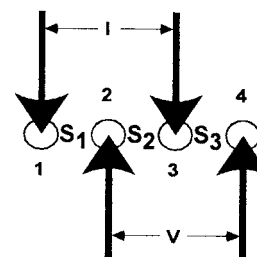

FIG. 1B
Staggered Colinear Array

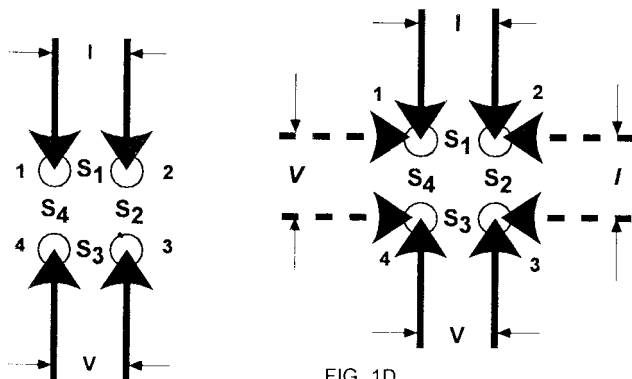

FIG. 1D
Phased Square Array
Current is conducted alternately
between pins 1 & 2 and then 2 & 3.

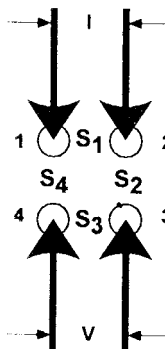

FIG. 1C
Square Array

FIG. 1 Four-Point Probe Configurations

highly conductive boundary within ± 0.25 mm (± 0.010 in.) is required. In most instances a vernier depth gage is suitable.

6.4.2 *Toolmaker's Microscope*, capable of measuring increments of $2.5 \mu\text{m}$.

7. Test Specimen

7.1 The test article shall be either a display substrate that has been sputter coated with the thin film of interest, or, alternatively, a dummy plate coated in the same operation as the substrate of interest.

7.2 The conductive film must be thick enough that it is continuous. Generally this requires that the film be at least 15 nm (150 \AA) thick.

7.3 The area to be tested shall be free of contamination and mechanical damage, but shall not be cleaned or otherwise prepared.

7.4 Note that a sputtered film may also coat the edge of the glass and can coat the back side of the substrate ("over spray"). Thus the edge of the glass cannot be automatically assumed to be insulating. If sheet resistance determinations will be made within a distance of 20 times the probe spacing to an edge of the substrate it is necessary to ensure that the film terminates at the edge.

7.4.1 To eliminate over spray error in compensating for edge effects at an insulating boundary (see 10.2.2), either make a fresh cut of the substrate, grind the edge to remove any residual film, or etch the film from the edge.

7.4.2 Scribing the substrate near the edge using a glass scribe is not a reliable remedy.

7.4.3 Use a simple 2-point probe ohmmeter to verify that the substrate edge is insulating.

7.5 *Soda Lime Glass Substrates*—Special precautions may be required in measuring the sheet resistance of sputtered thin films on soda lime glass substrates. The surface of this glass can be somewhat electrically conductive (on the order of $1 \times 10^{-6} \Omega^2$) when the ambient relative humidity is about 90 % or higher.

7.5.1 The glass conductivity degradation may interfere with the sheet resistance measurement when specimen sheet resistivity is 1000 Ω /square or higher.

7.5.2 Ensure that films >1000 Ω /square sheet resistance deposited on soda lime glass are conditioned at less than 50 % humidity for at least 48 h prior to measurement, and that the measurement is performed at an ambient relative humidity less than 50 %.

7.5.3 Note that at relative humidity less than 50 % the surface resistance of soda lime glass is on the order of $1 \times 10^{12} \Omega$ /square.

8. Suitability of Test Equipment

8.1 *Equipment Qualification*—The probe assembly and the electrical equipment must be qualified for use as specified in Test Method F 390, paragraphs 7.1 through 7.2.3.3 on suitability.

8.2 *Voltmeter Malfunctions*—Modern solid state voltmeters using field effect transistors in the signal input circuitry are electrically fragile; failure of a field effect transistor degrades the input impedance. This failure mode is a particular hazard if input protection is not provided and if films with static charges are probed. It is recommended that the error from the voltmeter input impedance be checked periodically using the test circuit illustrated in Fig. 2.

8.2.1 *Input Impedance Error*—To measure the input impedance error, set the constant current, I , and take the voltage reading, V . Then, without changing I , make a second reading, V_d , with R_d shorted (close switch IMP, Fig. 2). The impedance error for $R_{imp} \gg R_v$ is approximately as follows:

$$E_{imp} = [(V_d - V)/V_d] \times 100 \quad (1)$$

where:

E_{imp} = the percentage voltage error contributed by the finite voltmeter input impedance.

8.2.2 *Common Mode Rejection Error*—State of the art voltmeters typically have high common mode rejection (on the order of 90 dB), but this may be degraded by the failure of a field effect transistor in the input circuit (8.2). Reduction of common mode rejection will cause errors in measuring sheet resistance if unequal probe contact resistances contribute high common mode voltages. Common mode rejection error may be measured using the test circuit shown in Fig. 2.

8.2.2.1 To measure the common mode rejection error, set the constant current, I , and take the voltage reading, V . Then,

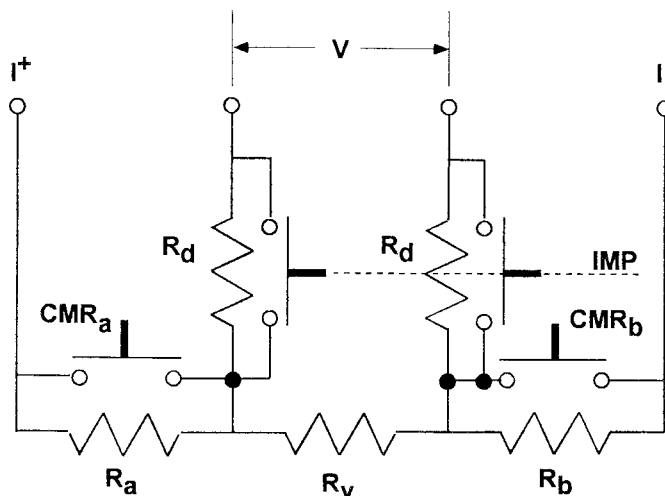

NOTE 1—Set R_v = approximately the resistance measured on the specimen film of interest as follows:

$$R_a = R_b = R_v \\ R_d = 100 \times R_v$$

NOTE 2—Set I approximately the same as used for measurement of the specimen film of interest, typically 0.05 to 0.50 mA, so that V is comparable to that obtained in performing the sheet resistance determination.

NOTE 3—If R_v is set equal to a multiple of $\ln 2 / 2\pi$ for the in line probe of Fig. 1A, or $\ln 2 / 2\pi$ for a square array, then the magnitude of V is the sheet resistance value for an equivalent film measurement.

FIG. 2 Voltmeter Test Circuit

without changing I , make a second reading, V_a , with R_a shorted (close switch CMR_a), and finally complete a third reading, V_b , with R_b shorted (open CMR_a , close CMR_b). The common mode error is approximately as follows:

$$E_{cm} = \{1/2[(V_a - V)^2 + (V_b - V)^2]^{1/2}\}/V \times 100 \quad (2)$$

where:

E_{cm} = the percentage voltage error contributed by common mode voltages. The voltmeter must be repaired or replaced if E_{cm} exceeds 0.5 %.

8.3 *Voltage Limited Constant Current Supply*—In cases of high sheet resistance or high contact resistance, the voltage at the constant current source may not be high enough to drive the set current. This condition causes very large errors in computed sheet resistance.

8.3.1 Ensure that the measuring circuit contains a direct reading ammeter (see Test Method F 390, 5.2.4), permitting the operator to verify the true current flow.

8.3.2 Alternatively, provide electronic means to divide the measured voltage by the measured current. This ratio may be provided digitally or by a dual-slope integrating voltmeter with reference voltage inputs.

8.4 *Avoid Arcing On the Film*—As the probes are making or breaking contact with the film, the voltage driving the constant current source can cause arcing damage to the film and the probes. To avoid arcing, keep the constant current supply voltage low or provide switching preventing application of current supply voltage until after contact is made with the film under test.

NOTE 1—Ten-volt potential typically does not cause visible arcing

damage, but 100 volt potential often does.

8.5 Fabrication and Use of Sheet-Resistance Reference Specimens—It is useful to maintain sheet-resistance reference specimens for use in verifying the proper performance of the measuring apparatus.

8.5.1 Rectangular sheets of etched glass nominally 50 by 75 mm (2.0 by 3.0 in.) are suitable substrates. The roughness of the etched surface greatly improves abrasion resistance.

8.5.2 The reference film, applied to the substrate, may be a nominally 40 nm (400 Å) thick sputtered tin oxide coating doped with nominally 5 weight % antimony or fluorine. This material demonstrates good chemical stability and abrasion resistance, and sheet resistance on the order of 1500 Ω/square.

8.5.2.1 Tin oxide is a photo conductor with very long carrier lifetimes. Thus the lighting conditions must be controlled to prevent exposure to direct light, or the film must be recalibrated (see 8.5.4.2) before each use.

8.5.3 A double layer of nominally 100-nm (1000-Å) sputtered indium-tin oxide at 90/10 composition ratio covered with 40 nm (400Å) doped tin oxide (see 8.5.2) for abrasion resistance forms a satisfactory reference film in the 25 Ω/square sheet resistance range. The photo conductive effect is negligible, but films may exhibit long term resistivity drift. Periodic recalibration (see 8.5.4.2) is required.

8.5.4 After applying the reference film, highly conductive bus bars nominally 12.5 mm (0.5 in.) wide are deposited over the film along two opposite “short” edges of the substrate, as illustrated in Fig. 3. The free conducting area of film is thus a nominally 50 by 50 mm² (2.0 by 2.0 in.).

8.5.4.1 A sputtered chromium adhesion layer, nominally 100-nm (1000-Å) thick, upon which is sputtered a thick copper conductive layer nominally 1000 nm (10 000 Å) with a sheet resistance of 50 mΩ/square or less is a satisfactory bus electrode for reference films of 20 Ω per square or greater. Reference films less than 20 Ω per square should have a copper wire soldered to the lengths of the bus electrodes, or should have the thickness of the copper film electrodes increased proportionately.

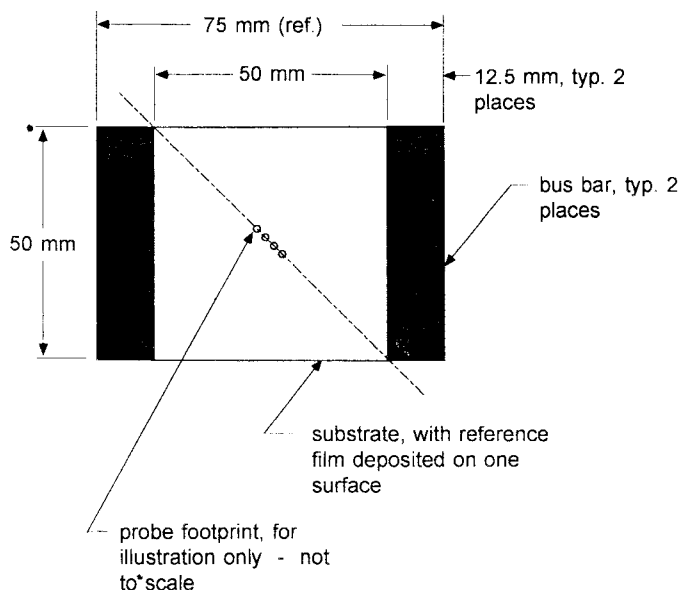

FIG. 3 Sheet Resistance Reference Specimen

8.5.4.2 The sheet resistance of the reference film may be calibrated using a 2-point or 4-point method, using the bus bars as contact lines. The measured V/I ratio is the sheet resistance for the square reference sample. No correction factors are required.

8.5.5 The conditions and precautions prescribed in 7.2-7.5.3 pertain to sheet resistance reference specimens.

8.5.6 The probe and associated measuring apparatus are checked by applying the measuring procedure, Sections 9 and 10 to the reference film. Probe near the center of the reference film. Edge corrections will be small, or indeed negligible, because the conductive bus tends to cancel the insulating edge effects. If an in-line probe is placed diagonally, and centered, the edge effects exactly cancel. This is illustrated in Fig. 3.

8.6 Estimation of Probe Spacing Error—There is usually some error in the fabrication of the probes and some lateral “wobble” of the probes in use because of their spring loaded sliding action in the probe holder. The probe spacing and wobble errors are estimated as follows:

8.6.1 Systematic Probe Spacing Error—Perform the probe assembly spacing test specified in Test Method F 390 paragraphs 7.1.1.1 through 7.1.2.4. Paragraph 7.1.2.5 of Test Method F 390 gives the correction for the systematic spacing error, F_{sp} , for a collinear probe set.

8.6.1.1 Computing the systematic pin spacing error for a square array requires first determining the length of the two diagonals. With reference to Fig. 1C:

S_{13} = length of line segment connecting pins 1 and 3, and
 S_{24} = length of line segment connecting pins 2 and 4.

8.6.1.2 For evaluating the systematic pin spacing error the equation is as follows:

$$F_{sp} = \frac{\ln 2}{\ln[(S_{13} \times S_{24}) / (S_2 \times S_4)]} \quad (3)$$

8.6.1.3 Use the average values of S_1 , S_2 , S_3 , and S_4 in computing F_{sp} using the equation in 8.6.1.2: see Test Method F 390, paragraphs 7.1.1.1 and 7.1.1.2. For the purposes of this practice S_{13} and S_{24} may be determined graphically by directly scaling a 25-times magnified sketch of the pin arrangement.

8.6.1.4 The phased square array, Fig. 1D, is designed to compensate for almost all pin spacing inequalities (see section 8.6.1.5). In this case:

$$F_{sp} = 1.000. \quad (4)$$

8.6.1.5 Note that the phased square array does not compensate for probes whose imprint pattern is a rhombus, that is, a parallelogram with four equal sides. Use 8.6.1.2 in this instance to compute F_{sp} .

8.6.2 Random Spacing Errors Caused by Probe Wobble—Start by computing the fractional spacing wobble by taking the ratio $s_i / S_{i \text{ avg.}}$ for each of the pin spacing intervals. Index i runs 1, 2, 3, for a collinear array, or 1 through 4 for a square probe set: $S_{i \text{ avg.}}$ is the average of ten pin spacing measurements as described in Test Method F 390, paragraph 7.1.2.2; s_i is the standard deviation of the ten measurements for each pin spacing interval, Test Method F 390 7.1.2.3.

NOTE 2—It is assumed that measuring error is negligible compared to the pin wobble.

8.6.3 Compute the average fractional spacing wobble s/S ,

where s is the average of the s_i and S is the average of the S_i avg.

$$s = (1/n) \sum_{i=1}^n s_i, \quad (5)$$

where:

$n = 3$ for collinear array, 4 for a square one, and

$$S = (1/n) \sum_{i=1}^n S_i, \quad (6)$$

where:

indices are as just stated.

8.6.4 The contribution of probe spacing wobble to the dispersion in measured resistance values, as indicated by the wobble contribution to specimen-resistance total standard deviation, for $s/S < 0.1$, is computed using the factors given in Table 1. The numerical contribution to the specimen-resistance standard deviation, s (wobble), is given as follows:

$$s(\text{wobble}) = (s/S) \times F_w \times R_{\text{avg}}, \quad (7)$$

where:

R_{avg} = the measured average resistance (10.1), and

F_w = information from Table 1.

9. Procedure

9.1 Connect the current source and voltage measuring apparatus to the probe pins as indicated in Fig. 1. Do not activate current source: note paragraph 8.4.

9.2 Lower the probe perpendicularly on to the test specimen, ensuring that the probe tips do not skid or slip across the surface on contact.

9.3 Establish a current between the current carrying probes. Record the voltage and current. Record the position of the probe to ± 0.25 mm (± 0.010 in.) if the probe tips are closer to an insulating or highly conductive edge or corner than 20 times the nominal probe spacing distance (see Fig. 4 and Fig. 5).

9.4 Turn off the current source.

9.5 Raise the probe from the test specimen.

9.6 Repeat the measurement, 9.2-9.5, until 10 tests have been completed.

9.7 **Caution**—Spurious and inaccurate results can arise from a number of sources. Important precautions are provided in Test Method F 390, 8.5.1 through 8.5.3.

10. Calculations

10.1 Calculate the specimen resistance, R_i , from the ratio of measured voltage and current for each of the 10 determinations (9.2-9.4).

10.2 *Application of Correction Factors:*

10.2.1 Refer to Table 2 to obtain the probe array geometry correction factor, F_g .

10.2.2 If the probe pin position is closer to an insulating edge or corner than 20 times the probe pin spacing, as

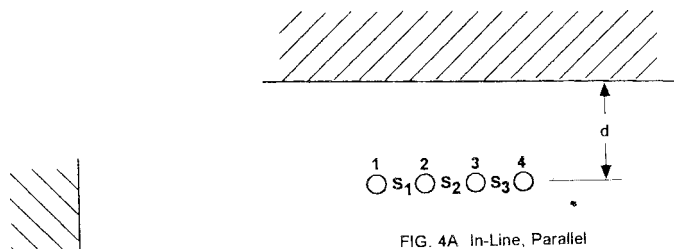

FIG. 4A In-Line, Parallel

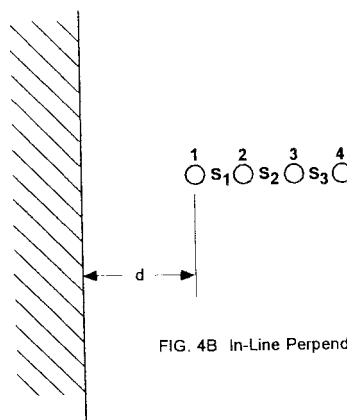

FIG. 4B In-Line Perpendicular

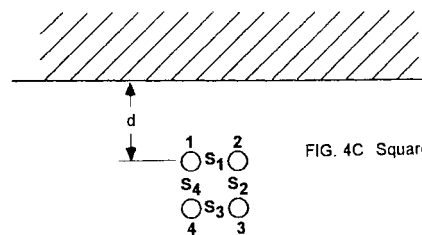

FIG. 4C Square

FIG. 4 Probe Arrays Near an Edge Boundary

illustrated in Fig. 4 and Fig. 5, determine the edge effect correction factor, F_e , from Table 3 or Table 4. Use linear interpolation, as required.

10.2.3 If the probe pin position is closer to a highly conductive edge or corner than 20 times the probe pin spacing, as illustrated in Fig. 4 and Fig. 5, determine the edge effect correction factor, F_e , from Table 5 or Table 6. Use linear interpolation, as required.

10.2.4 Recall the probe spacing systematic correction factor, F_{sp} , computed in 8.6.1.

10.2.5 Note that the film thickness correction factor, Test Method F 390 paragraph 9.5, is negligible for sputtered films of interest in flat panel display manufacture.

10.2.6 Compute the sheet resistance for each individual measurement, R_{si} , as follows:

$$R_{\text{si}} = (R_i \times F_g \times F_{\text{sp}}) / F_e. \quad (8)$$

10.3 Compute the average sheet resistance, R_{savg} , as follows:

$$R_{\text{savg}} = (1/10) \sum_{i=1}^{10} R_{\text{si}}. \quad (9)$$

10.4 Compute the sample standard deviation as follows:

$$s = (1/3) \left[\sum_{i=1}^{10} (R_{\text{si}} - R_{\text{savg}})^2 \right]^{1/2} \quad (10)$$

10.5 *Requirement*—For use as a referee method the sample standard deviation s shall be less than 1 % of R_{savg} . In routine application the sample standard deviation s shall be less than 2 % of R_{savg} .

TABLE 1 Probe Wobble Factor, F_w

Average Fractional Wobble, s/S	Collinear (Fig. 1A) F_w	Staggered Collinear (Fig. 1B) F_w	Square (Fig. 1C) F_w	Phased Square Array (Fig. 1D) F_w
<0.1	1.27	1.91	1.22	0.0017

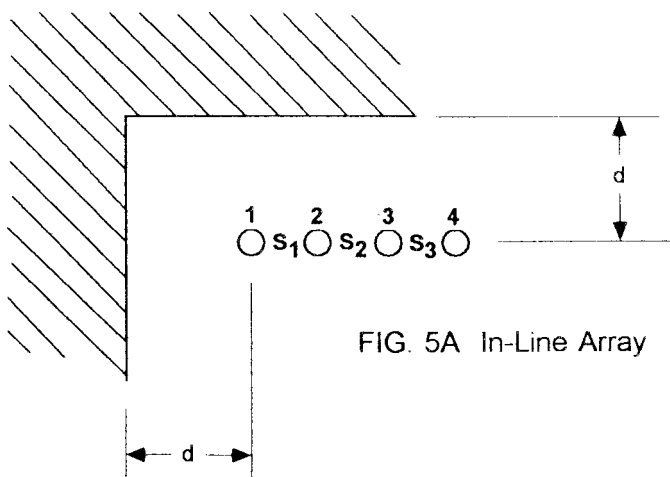

FIG. 5A In-Line Array

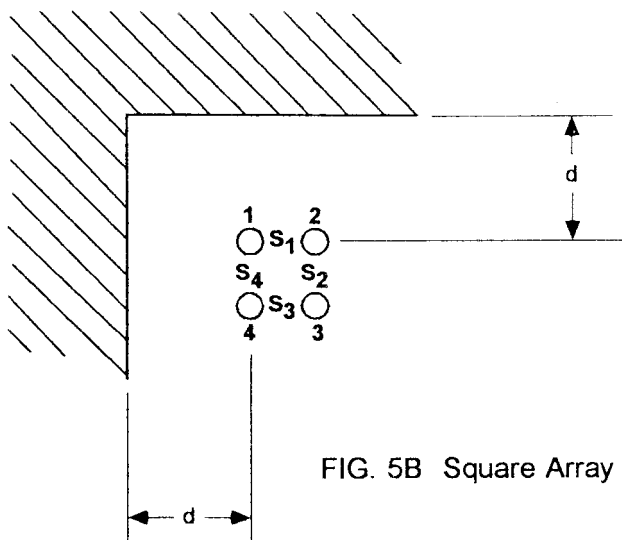

FIG. 5B Square Array

FIG. 5 Probe Arrays Near a Square Corner

TABLE 2 Probe Array Geometric Correction Factor, F_g

Collinear (Fig. 1A) F_g	Staggered Collinear (Fig. 1B) F_g	Square (Fig. 1C) F_g	Phased Square Array (Fig. 1D) F_g
$\pi/\ln 2$ 4.532	$2\pi/\ln 3$ 5.719	$2\pi/\ln 2$ 2.885	$2\pi/\ln 2$ 2.885

11. Report

11.1 For a referee test the report shall contain the following information:

- 11.1.1 Operator name, date, description of test equipment,
 - 11.1.2 A description of the specimen, including:
 - 11.1.2.1 Type of film,
 - 11.1.2.2 Specimen identification, and
 - 11.1.2.3 Brief description of visual appearance and physical condition,
 - 11.1.3 Dimensions and data, including:
 - 11.1.3.1 Length and width of specimen,
 - 11.1.3.2 Description of 4-point probe, including average values and standard deviations of probe spacing,
 - 11.1.3.3 Data verifying proper functioning of voltmeter (8.2), and
 - 11.1.3.4 Measurement system validation data obtained from testing one or more reference specimens (8.5),
 - 11.1.4 Measured values of current and voltage,
 - 11.1.5 Measured distances from insulating or highly conductive edges or corners for each current/voltage pair (required if test point is closer to a specimen boundary than 20 times the average probe spacing),
 - 11.1.6 Values of correction factors used,
 - 11.1.7 Calculated individual values of sheet resistance, and
 - 11.1.8 Computed average sheet resistance, and standard deviation.
- 11.2 For a routine test only such items as are deemed significant by the parties to the test need be reported.
- 11.3 *Film Uniformity*—A recommended method of describing film uniformity for rectangular substrates is to measure the sheet resistance R_s in five or more locations, typically near the four corners and at the center. It is convenient, when possible, to define sampling areas far enough removed from substrate boundaries that edge corrections to R_s may be ignored. The uniformity measure, U , is computed from the equation:

$$U = 100(R_{s\max} - R_{s\min}) / (R_{s\max} + R_{s\min}) \%, \quad (11)$$

where:

$R_{s\max}$ and $R_{s\min}$ are the maximum and minimum respectively of the five measured sheet resistance values.

12. Keywords

12.1 electrical resistance; electrical sheet resistance; flat panel displays; four point probe; resistance; sputtered thin films; thin conductive films on glass; thin films

 **F 1711**

TABLE 3 Correction Factor F_e , When Probing Near an Insulating Edge

d/S_1	In-Line Probe, Conventional (Fig. 1A), Parallel (Fig. 4A) F_e	In-Line Probe, Conventional (Fig. 1A), Perpendicular (Fig. 4B) F_e	In-Line Probe, Staggered (Fig. 1B), Parallel (Fig. 4A) F_e	In-Line Probe, Staggered (Fig. 1B), Perpendicular (Fig. 4B) F_e	d/S_1	Square Array, (Fig. 1C), (Fig. 4C), Current to Pins 1 and 2 or 3 and 4, F_e	Square Array, (Fig. 1C), (Fig. 4C), Current to Pins 2 and 3 or 1 and 4, F_e
0.0	2.000	1.339	2.000	1.530	0.0	2.00	0.839
0.5	1.661	1.161	1.732	1.262	0.5	1.322	1.161
1.0	1.339	1.096	1.435	1.159	1.0	1.150	1.117
2.0	1.117	1.047	1.176	1.078	2.0	1.057	1.052
4.0	1.033	1.018	1.053	1.031	4.0	1.018	1.017
8.0	1.008	1.006	1.014	1.010	8.0	1.005	1.005
15.0	1.002	1.002	1.004	1.003	15.0	1.002	1.001
30.0	1.001	1.001	1.001	1.001	30.0	1.000	1.000
60.0	1.000	1.000	1.000	1.000	60.0	1.000	1.000

TABLE 4 Correction Factor F_e , When Probing Near an Insulating Square corner

d/S_1	In-Line Probe, Conventional (Fig. 1A), (Fig. 5A) F_e	In-Line Probe, Staggered (Fig. 1B), (Fig. 5A) F_e	Square Probes (Figs. 1C and D) (Fig. 5B), F_e
0.0	2.678	3.070	1.678
0.5	1.945	2.197	1.472
1.0	1.489	1.684	1.267
2.0	1.180	1.281	1.108
4.0	1.054	1.089	1.035
8.0	1.015	1.025	1.010
15.0	1.004	1.008	1.003
30.0	1.001	1.002	1.001
60.0	1.000	1.000	1.000

TABLE 5 Correction Factor, F_e , When Probing Near a Highly Conductive Edge

d/S_1	In-Line Probe, Conventional (Fig. 1A), Parallel (Fig. 4A) F_e	In-Line Probe, Conventional (Fig. 1A), Perpendicular (Fig. 4B) F_e	In-Line Probe, Staggered (Fig. 1B), Parallel (Fig. 4A) F_e	In-Line Probe, Staggered (Fig. 1B), Perpendicular (Fig. 4B) F_e	d/S_1	Square Array, (Fig. 1C), (Fig. 4C), Current to Pins 1 and 2 or 3 and 4, F_e	Square Array (Fig. 1C), (Fig. 4C), Current to Pins 2 and 3 or 1 and 4, F_e
0.0	0.000	0.661	0.000	0.465	0.0	0.000	1.161
0.5	0.339	0.839	0.268	0.738	0.5	0.678	0.839
1.0	0.661	0.904	0.565	0.841	1.0	0.847	0.883
2.0	0.883	0.953	0.824	0.922	2.0	0.943	0.948
4.0	0.967	0.982	0.947	0.969	4.0	0.982	0.983
8.0	0.992	0.994	0.986	0.990	8.0	0.995	0.995
15.0	0.998	0.998	0.996	0.997	15.0	0.998	0.999
30.0	0.999	0.999	0.999	0.999	30.0	1.000	1.000
60.0	1.000	1.000	1.000	1.000

TABLE 6 Correction Factor, F_e , When Probing Near a Highly Conductive Square Corner

d/S_1	In-Line Probe Conventional (Fig. 1A), (Fig. 5A) F_e	In-Probe, Staggered (Fig. 1B), (Fig. 5A) F_e	Square Probes (Figs. 1C and D) (Fig. 5B), F_e
0.0	-0.681	-1.070	0.322
0.5	0.055	0.197	0.528
1.0	0.511	0.316	0.733
2.0	0.820	0.719	0.892
4.0	0.946	0.911	0.965
8.0	0.985	0.975	0.990
15.0	0.996	0.992	0.997
30.0	0.999	0.998	0.999
60.0	1.000	1.000	1.000

APPENDIXES

(Nonmandatory Information)

X1. BRIEF DERIVATION ON RELATIONSHIP BETWEEN R_s , V , and I

X1.1 Consider a point current source, I , on an infinite uniform conducting sheet. The current density, j , at a distance, r , from the source and the electric field, E , is as follows:

$$j = I/2\pi r, \text{ and } E = j R_s. \quad (X1.1)$$

X1.2 The potential difference, V_{ab} between two points, distances a and b from the source is as follows:

$$V_{ab} = I R_s / 2\pi \int_{r=b}^{r=a} dr/r, \quad (X1.2)$$

$$= I R_s \ln (a/b)/2\pi. \quad (X1.3)$$

where:

\ln = the natural logarithm, base e . This relationship is used repeatedly for solving for various arrays and boundary conditions.

X1.3 For example, the in-line array (Fig. 1A) has a current source, I , at point 1. The voltage from 2 to 3 due to this current source is as follows:

$$\begin{aligned} V_{23} &= I R_s \ln (2S/S)/2\pi, \\ &= I R_s \ln(2)/2\pi. \end{aligned} \quad (X1.4)$$

X1.4 The contribution from the current sink, $-I$, at point 4 is the same, so the total potential drop from 2 to 3 is as follows:

$$V_{23} = I R_s \ln(2)/\pi. \quad (X1.5)$$

X1.5 The equations for the other arrays are listed in Table 2.

X1.6 Note that for a current source close to an insulating line boundary of the sheet, the method of a mirror source equidistant on the other side of the boundary is very useful. For an orthogonal corner insulating boundary, one uses three mirror sources, so that there is one source in each “quadrant”. For a source surrounded by a rectangular insulating boundary, an infinite array of sources is appropriate. Mirror sources are illustrated in Fig. X1.1.

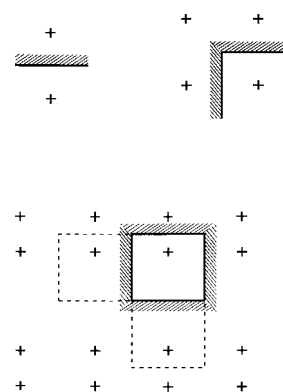

NOTE 1—For a very conductive boundary, the mirror sources have the opposite sign.

FIG. X1.1 Mirror Image Current Sources

X2. EQUATIONS FOR INCREASE WHEN PROBING NEAR AN INSULATING LINE BOUNDARY

Fig. 2A T, In-Line, I to 1 and 4: $1 + \frac{1}{2\ln 2} \ln \frac{(2d+2)(2d+4)}{(2d+1)(2d+5)}$ (X2.1)

Fig. 2B //, In-Line, I to 1 and 4: $1 + \frac{1}{2\ln 2} \ln \frac{(2d)^2 + 4}{(2d)^2 + 1}$ (X2.2)

Fig. 2A T, In-Line, Staggered: $1 + \frac{1}{\ln 3} \ln \frac{(2d+3)^2}{(2d+1)(2d+5)}$ (X2.3)

Fig. 2B //, In-Line, Staggered: $1 + \frac{1}{2\ln 3} \ln \frac{(2d)^2 + 9}{(2d)^2 + 1}$ (X2.4)

Fig. 2C Square, I to 1 and 2 or 3 and 4: $1 + \frac{1}{\ln 2} \ln \frac{(2d+1)^2 + 1}{(2d+1)^2}$ (X2.5)

Fig. 2C Square, I to 1 and 4 or 2 and 3:
 $1 + \frac{1}{2\ln 2} \ln \frac{((2d+1)^2 + 1)^2}{((2d)^2 + 1)((2d+2)^2 + 1)}$ (X2.6)

The American Society for Testing and Materials takes no position respecting the validity of any patent rights asserted in connection with any item mentioned in this standard. Users of this standard are expressly advised that determination of the validity of any such patent rights, and the risk of infringement of such rights, are entirely their own responsibility.

This standard is subject to revision at any time by the responsible technical committee and must be reviewed every five years and if not revised, either reapproved or withdrawn. Your comments are invited either for revision of this standard or for additional standards and should be addressed to ASTM Headquarters. Your comments will receive careful consideration at a meeting of the responsible technical committee, which you may attend. If you feel that your comments have not received a fair hearing you should make your views known to the ASTM Committee on Standards, at the address shown below.

This standard is copyrighted by ASTM, 100 Barr Harbor Drive, PO Box C700, West Conshohocken, PA 19428-2959, United States. Individual reprints (single or multiple copies) of this standard may be obtained by contacting ASTM at the above address or at 610-832-9585 (phone), 610-832-9555 (fax), or service@astm.org (e-mail); or through the ASTM website (www.astm.org).