



Standard Specification for Gold Wire for Semiconductor Lead Bonding¹

This standard is issued under the fixed designation F 72; the number immediately following the designation indicates the year of original adoption or, in the case of revision, the year of last revision. A number in parentheses indicates the year of last reapproval. A superscript epsilon (ϵ) indicates an editorial change since the last revision or reapproval.

1. Scope

1.1 This specification covers round drawn/extruded gold wire for internal semiconductor device electrical connections. Four classifications of wire are distinguished, (1) copper-modified wire, (2) beryllium-modified wire, (3) high-strength wire, and (4) special purpose wire.

NOTE 1—Trace metallic elements have a significant effect upon the mechanical properties and thermal stability of high-purity gold wire. It is customary in manufacturing to add controlled amounts of selected impurities to gold to modify or stabilize bonding wire properties or both. This practice is known variously as “modifying,” “stabilizing,” or “doping.” The first two wire classifications denoted in this specification refer to wire made with either of two particular modifiers, copper or beryllium, in general use. In the third and fourth wire classifications, “high-strength” and “special purpose” wire, the identity of modifying additives is not restricted.

1.2 The values stated in SI units shall be regarded as the standard.

1.2.1 A mixed system of metric and inch-pound units is in widespread use for specifying semiconductor lead-bonding wire. SI-equivalent values of other commonly used units are denoted by parentheses in text and tables.

1.3 The following hazard caveat pertains only to the test method portion, Section 9, of this specification. *This standard does not purport to address all of the safety concerns, if any, associated with its use. It is the responsibility of the user of this standard to establish appropriate safety and health practices and determine the applicability of regulatory limitations prior to use.*

2. Referenced Documents

2.1 ASTM Standards:

- F 16 Test Methods for Measuring Diameter or Thickness of Wire and Ribbon for Electronic Devices and Lamps²
- F 205 Test Method for Measuring Diameter of Fine Wire by Weighing²
- F 219 Test Methods of Testing Fine Round and Flat Wire for Electron Devices and Lamps²
- F 584 Practice for Visual Inspection of Semiconductor Lead-Bonding Wire²

¹ This specification is under the jurisdiction of ASTM Committee F-1 on Electronics and is the direct responsibility of Subcommittee F01.07 on Wire Bonding.

Current edition approved April 15, 1995. Published June 1995. Originally published as F 72 – 66 T. Last previous edition F 72 – 94.

² Annual Book of ASTM Standards, Vol 10.04.

3. Ordering Information

3.1 Orders for material under this specification shall include the following information:

- 3.1.1 Classification: copper-modified, beryllium-modified, high strength, or special purpose,
- 3.1.2 Quantity,
- 3.1.3 Purity (Section 4),
- 3.1.4 Type, hard, stress relieved, or annealed (Section 5),
- 3.1.5 Breaking load and percentage elongation range (Section 5),
- 3.1.6 Wire diameter (Section 6),
- 3.1.7 Spool type, length of wire per spool, and type of wind (Section 11),
- 3.1.8 Despooling, left-handed unwind or right-handed unwind (Section 11), and,
- 3.1.9 Packaging and marking (Section 12).

4. Chemical Composition

- 4.1 Copper-modified material shall conform to the chemical requirements specified in Table 1.
- 4.2 Beryllium-modified material shall conform to the chemical requirements specified in Table 2.
- 4.3 High-strength material shall conform to the chemical requirements specified in Table 3.
- 4.4 Special purpose material shall be in accordance with Table 4.

NOTE 2—Copper-modified wire is used on thermocompression wire bonding machines. Beryllium-modified material is often preferred on high-speed automated thermocompression or thermosonic bonding equipment. High-strength wire was developed for use on some very high speed automated thermosonic bonders.

5. Mechanical Properties

5.1 Material specified by this standard may be either of two types:

- 5.1.1 *Hard*—Wire, as drawn/as extruded.
- 5.1.2 *Annealed*—Wire, annealed after drawing/extruding.
- 5.2 *Breaking Load and Elongation*—The tension test shall be the standard test for determining the mechanical properties, and acceptance or rejection shall depend on the breaking load and percent elongation at failure of a 254-mm (10.0-in.) length of wire.

5.2.1 Hard wire shall conform to the requirements of Table 5 for copper-modified gold wire and to the requirements of Table 6 for beryllium-modified gold wire.

TABLE 1 Chemical Requirements, Copper-Modified Gold Bonding Wire

Element	Composition, Weight, %
Gold, min	99.99
Beryllium, max	0.0001
Copper	0.003–0.006
Silver, max	0.006
Other impurities, max each	0.003
Total of all detectable elements, max	0.01

TABLE 2 Chemical Requirements, Beryllium-Modified Gold Bonding Wire

Element	Composition, Weight, %
Gold, min	99.99
Beryllium	0.0003–0.0010
Other impurities, max each	0.003
Total of all detectable impurities, max	0.01

TABLE 3 Chemical Requirements, High-Strength Gold Bonding Wire

Element	Composition, Weight, %
Gold, min	99.99
Total of all detectable impurities, max	0.01

TABLE 4 Chemical Requirements, Special Purpose Gold Bonding Wire

Element	Composition, Weight, %
Gold	Not restricted
Other principal elements	Not restricted
Total of all detectable elements	Not restricted

TABLE 5 Breaking Load and Elongation of Hard Wire—Copper-Modified Gold

Nominal Diameter, μm (in.)	Breaking Load, min, N (gf)	Elongation in 254 mm (10.0 in.), %
13 (0.00050)	0.029 (3.0)	0.5 to 2.0, incl
18 (0.00070)	0.059 (6.0)	0.5 to 2.0, incl
20 (0.00080)	0.078 (8.0)	0.5 to 2.0, incl
23 (0.00090)	0.127 (13.0)	1.0 to 2.5, incl
25 (0.0010)	0.157 (16.0)	1.0 to 2.5, incl
28 (0.0011)	0.196 (20.0)	1.0 to 2.5, incl
30 (0.0012)	0.235 (24.0)	1.0 to 2.5, incl
31.8 (0.00125)	0.255 (26.0)	1.0 to 2.5, incl
33 (0.0013)	0.275 (28.0)	1.0 to 2.5, incl
38 (0.0015)	0.343 (35.0)	1.0 to 2.5, incl
51 (0.0020)	0.686 (70.0)	1.0 to 3.0, incl

5.2.2 Stress relieved/annealed wire shall conform to the requirements of Table 7 for copper-modified gold wire, the requirements of Table 8 for beryllium-modified gold wire, to the requirements of Table 9 for high-strength wire, and to the requirements of Table 10 for special purpose wire.

NOTE 3—Hard wire is generally used for ultrasonic wire bonding. Annealed wire is used for thermocompression and thermosonic bonding.

6. Dimensions and Permissible Variations

6.1 Wire diameters shall be expressed in μm (or equivalent decimal fractions of an inch). Tolerances for the various size ranges are specified in Table 11.

TABLE 6 Breaking Load and Elongation of Hard Wire—Beryllium-Modified Gold and High-Strength Gold

Nominal Diameter, μm (in.)	Breaking Load, min, N (gf)	Elongation in 254 mm (10.0 in.), %
13 (0.00050)	0.039 (4.0)	0.5 to 2.0, incl
18 (0.00070)	0.069 (7.0)	0.5 to 2.0, incl
20 (0.00080)	0.088 (9.0)	0.5 to 2.0, incl
23 (0.00090)	0.147 (15.0)	1.0 to 2.5, incl
25 (0.0010)	0.177 (18.0)	1.0 to 2.5, incl
28 (0.0011)	0.216 (22.0)	1.0 to 2.5, incl
30 (0.0012)	0.265 (27.0)	1.0 to 2.5, incl
31.8 (0.00125)	0.284 (29.0)	1.0 to 2.5, incl
33 (0.0013)	0.314 (32.0)	1.0 to 2.5, incl
38 (0.0015)	0.392 (40.0)	1.0 to 2.5, incl
51 (0.0020)	0.736 (75.0)	1.0 to 3.0, incl

TABLE 7 Breaking Load and Elongation of Stress Relieved/Annealed Wire—Copper-Modified Gold

Nominal Diameter, μm (in.)	Breaking Load, min, N (gf)	Elongation in 254 mm (10.0 in.), %		
		Min	Max	Range ^A
13 (0.00050)	0.0098 (1.0)	0.5	3.0	2
18 (0.00070)	0.020 (2.0)	0.5	7.0	3
20 (0.00080)	0.029 (3.0)	0.5	8.0	3
23 (0.00090)	0.049 (5.0)	0.5	8.0	3
25 (0.0010)	0.059 (6.0)	0.5	10.0	3
28 (0.0011)	0.069 (7.0)	0.5	10.0	3
30 (0.0012)	0.078 (8.0)	0.5	10.0	3
31.8 (0.00125)	0.088 (9.0)	0.5	10.0	3
33 (0.0013)	0.0981 (10.0)	0.5	10.0	3
38 (0.0015)	0.118 (12.0)	0.5	12.0	4
51 (0.0020)	0.196 (20.0)	0.5	15.0	4

^A A range of permissible elongation of at least the number of percentage points shown shall be selected from within the overall range designated by the minimum and maximum values for the given diameter. For example, for wire of 25- μm (0.0010-in.) diameter, copper-modified gold wire, permissible elongation of 4.0 to 7.0, 6.0 to 9.0, 7.0 to 10.0 %, etc., may be selected.

TABLE 8 Breaking Load and Elongation of Stress Relieved/Annealed Wire—Beryllium-Modified Gold

Nominal Diameter, μm (in.)	Breaking Load, min, N (gf)	Elongation in 254 mm (10.0 in.), %		
		Min	Max	Range ^A
13 (0.00050)	0.020 (2.0)	0.5	3.0	2
18 (0.00070)	0.029 (3.0)	0.5	7.0	3
20 (0.00080)	0.039 (4.0)	0.5	8.0	3
23 (0.00090)	0.059 (6.0)	0.5	8.0	3
25 (0.0010)	0.069 (7.0)	0.5	10.0	3
28 (0.0011)	0.078 (8.0)	0.5	10.0	3
30 (0.0012)	0.0981 (10.0)	0.5	10.0	3
31.8 (0.00125)	0.108 (11.0)	0.5	10.0	3
33 (0.0013)	0.118 (12.0)	0.5	10.0	3
38 (0.0015)	0.147 (15.0)	0.5	12.0	4
51 (0.0020)	0.245 (25.0)	0.5	15.0	4

^A A range of permissible elongation of at least the number of percentage points shown shall be selected from within the overall range designated by the minimum and maximum values for the given diameter. For example, for wire of 25- μm (0.0010-in.) diameter, permissible elongation of 4.0 to 7.0, 6.0 to 9.0, 7.0 to 10.0 %, etc., may be selected.

7. Workmanship, Finish, and Appearance

7.1 The wire surface shall be clean and free of finger oils and stains.

7.2 The wire surface shall be free of drawing/extrusion lubricant residues, particulate matter and other contaminants that would interfere with functional performance of the wire. The seller and the purchaser must agree upon acceptable standard of surface cleanliness.

**TABLE 9 Breaking Load and Elongation of Stress Relieved/
Annealed Wire—High-Strength Gold**

Nominal Diameter, μm (in.)	Breaking Load, min, N (gf)	Elongation in 254 mm (10.0 in.), % ^A	
		Min	Max
13 (0.00050)	0.020 (2.0)	0.5	3.0
18 (0.00070)	0.039 (4.0)	0.5	5.0
20 (0.00080)	0.040 (5.0)	0.5	6.0
23 (0.00090)	0.064 (6.5)	0.5	6.0
25 (0.0010)	0.078 (8.0)	0.5	6.0
28 (0.0011)	0.093 (9.5)	0.5	6.0
30 (0.0012)	0.113 (11.5)	0.5	6.0
31.8 (0.00125)	0.123 (12.5)	0.5	6.0
33 (0.0013)	0.132 (13.5)	0.5	6.0
38 (0.0015)	0.176 (18.0)	0.5	7.0
51 (0.0020)	0.314 (32.0)	0.5	7.0

^AExcept for 13 μm , 38 μm , and 51 μm , the minimum-maximum range is usually 3 percentage points, for example, 2 to 5, 3 to 6, and 4 to 7%. For 13 μm it is usually 1.5 percentage points, for example, 0.5 to 2, 1 to 2.5, and 1.5 to 3%. For 38 μm and 51 μm it is usually 4 percentage points, for example, 0.5 to 4.5, 1 to 5, 2 to 6, and 3 to 7%.

**TABLE 10 Breaking Load and Elongation of Stress Relieved/
Annealed Wire—Special Purpose**

Nominal Diameter, μm (in.)	Breaking Load, min, N (gf)	Elongation in 254 mm (10.0 in.), %		
		Min	Max	Range ^A
13 (0.00050)	To be determined	0.5	3.0	1.5
18 (0.00070)	between wire user	0.5	7.0	2.0
20 (0.00080)	and wire	0.5	8.0	2.0
23 (0.00090)	manufacturer	0.5	8.0	2.0
25 (0.0010)		0.5	10.0	2.0
28 (0.0011)		0.5	10.0	2.0
30 (0.0012)		0.5	10.0	2.0
31.8 (0.00125)		0.5	10.0	2.0
33 (0.0013)		0.5	10.0	2.0
38 (0.0015)		0.5	12.0	2.0
51 (0.0020)		0.5	15.0	2.0

^AA range of permissible elongation of at least the number of percentage points shown shall be selected from within the overall range designated by the minimum and maximum values for the given diameter. For example, for wire of 25- μm (0.0010-in.) diameter, a permissible elongation of 4.0 to 6.0, 6.0 to 8.0, 7.0 to 9.0%, etc., may be selected.

TABLE 11 Dimensional Tolerances

Nominal Diameter, μm (in.)	Standard Tolerance		Special Purpose Tolerance	
	% of Nominal Diameter	% of Nominal Weight	% of Nominal Diameter	% of Nominal Weight
13 (0.00050)	± 6	± 15	+ 6/-2	+ 1/-10
Over 13 to 25 (over 0.0005 to 0.0010), incl	± 3	± 10	+ 6/-2	+ 1/-6
Over 25 to 51 (over 0.0010 to 0.0020)	± 3	± 6	+ 3/-0.5	+ 1/-4

7.3 The surface shall be free of surface contamination that would degrade service life of the device to which it is attached. The seller and the purchaser must agree upon acceptable standard of surface cleanliness.

7.4 The wire surface shall be free of nicks, dents, scratches, or other blemishes deeper than 5% of the wire diameter. The surface shall be free of flaws protruding more than 5% of the wire diameter above the surface.

7.5 The wire shall despool without excessive curl that would degrade functional performance. The seller and the

purchaser must agree upon acceptable amount of curl. Curl is measured by the springback test (9.5).

7.6 The wire must be free of twist about the wire axis. Referring to wire twist test procedure (9.6), wire entwining upon itself one or more complete turns (9.6.5.4) is rejectable by the purchaser. Lesser degrees of twist may be acceptable, as agreed upon between seller and purchaser.

7.7 The wire cross section must not be out-of-round to such an extent that functional performance is impaired. The seller and the purchaser must agree upon acceptable amount of out-of-roundness.

NOTE 4—It is the intention of the directly responsible Subcommittee, F01.07, that the term “functional performance” be narrowly construed as follows: wire imperfections denoted in 7.2, 7.5, and 7.7 must not be of sufficient severity to excessively impair the operation of an otherwise normally functioning wire bonding machine. In practice, standards of adequate “functional performance” vary considerably, depending upon application.

8. Sampling

8.1 Unless otherwise agreed, conformance with Section 5 shall be determined by samples from each lot of wire.

8.2 *Lot Sampling*—A lot shall consist of all material from one melt or bar in a shipment against one order description.

8.3 Sampling Plan:

8.3.1 A spool of wire used for testing may not be useful for production. Choose a sampling plan that will permit scrapping of test spools as gold wire, particularly of small diameter, is easily damaged.

8.3.2 Select the number of spools that will give a representative sampling, as agreed upon between the purchaser and the seller.

8.4 Number of Samples:

8.4.1 Take samples from not less than 1% of the spools from each lot.

8.4.2 Take not less than three samples from each spool.

9. Test Methods

9.1 *Chemical Requirements*—Perform chemical analysis using an emission spectrograph or other method having equivalent sensitivity. Cross-check individual constituents (for example, copper or beryllium) by using atomic absorption spectrometric or other appropriate quantitative analytical method. The seller and the purchaser must agree upon analytical techniques to be employed.

9.2 *Breaking Load and Elongation*—Apply the tension test in accordance with Test Methods F 219.

9.3 *Wire Diameter*—Measure the wire diameter by one of the following methods:

9.3.1 Measure the diameter directly with apparatus and procedure in accordance with Test Methods F 16. Because annealed gold wire is very soft, exercise caution when using the direct-measurement method to prevent deformation of the wire.

9.3.2 Measure the wire diameter indirectly by weighing in accordance with Test Method F 205.

9.3.2.1 When the weight determination method is used, the following values shall be employed: gold density—19.34 g/cm³; weight of a 200-mm length of wire of 25.4- μm (0.00100-in.) diameter—1.96 mg.

9.3.2.2 *Calculation of Diameter from Weight*—When gold wire is weighed in 200-mm lengths, calculate the diameter as follows:

$$D (\mu\text{m}) = \sqrt{(W/1.96)} \times 25.4$$

$$D (\text{in}) = \sqrt{(W/1.96)} \times 0.001$$

where:

D = diameter, and

W = mass, mg/200 mm.

9.4 *Finish:*

9.4.1 *Visual Examination*—Perform visual examination using an optical binocular microscope in accordance with Practice F 584.

9.4.2 Use a scanning electron microscope to determine the depth of surface blemishes.

9.5 *Wire Curl Test:*

9.5.1 This test should be regarded as destructive. After the wire is despoiled to perform the test, the remainder of the wire on the spool will generally be too disturbed for use.

9.5.2 Test must be performed in a well-lighted work area free of air drafts.

9.5.3 *Equipment*—A fixture capable of supporting wire spool with its axis horizontal, and that permits the spool to rotate freely about its axis; metre stick; fine tweezers suitable for holding wire end (see Fig. 1).

9.5.4 Arrange the equipment as indicated schematically in

Fig. 1. Refer to Fig. 1 in performing the steps that follow.

9.5.5 *Procedure:*

9.5.5.1 Mount spool on fixture.

9.5.5.2 Using the tweezers, break the “starting end” wire end from its securing tab (Section 11). Gently pull the wire end, thus rotating the spool and dereeling the wire. Pulling force must not exceed 30 % of the wire breaking load. Pull the free wire end downward until 100 ± 0.5 cm of wire has been despoiled. Use the metre stick as a gage.

9.5.5.3 Release the wire end.

9.5.5.4 Measure the vertical springback of the free wire end, again using the metre stick as a gage.

9.5.5.5 The curl is defined as the springback determined in 9.5.5.4, measured in millimetres.

9.6 *Wire Axial Twist Test:*

9.6.1 This test should be regarded as destructive. After the wire is despoiled to perform the test, the remainder of the wire on the spool will generally be too disturbed for use.

9.6.2 Test must be performed in a well-lighted work area free of air drafts.

9.6.3 *Equipment*—A fixture capable of supporting wire spool with its axis horizontal, and that permits the spool to rotate freely about its axis; metre stick; fine tweezers suitable for grasping wire end.

9.6.4 Arrange the equipment as indicated schematically in Fig. 2. Refer to Fig. 2 in performing the steps that follow.

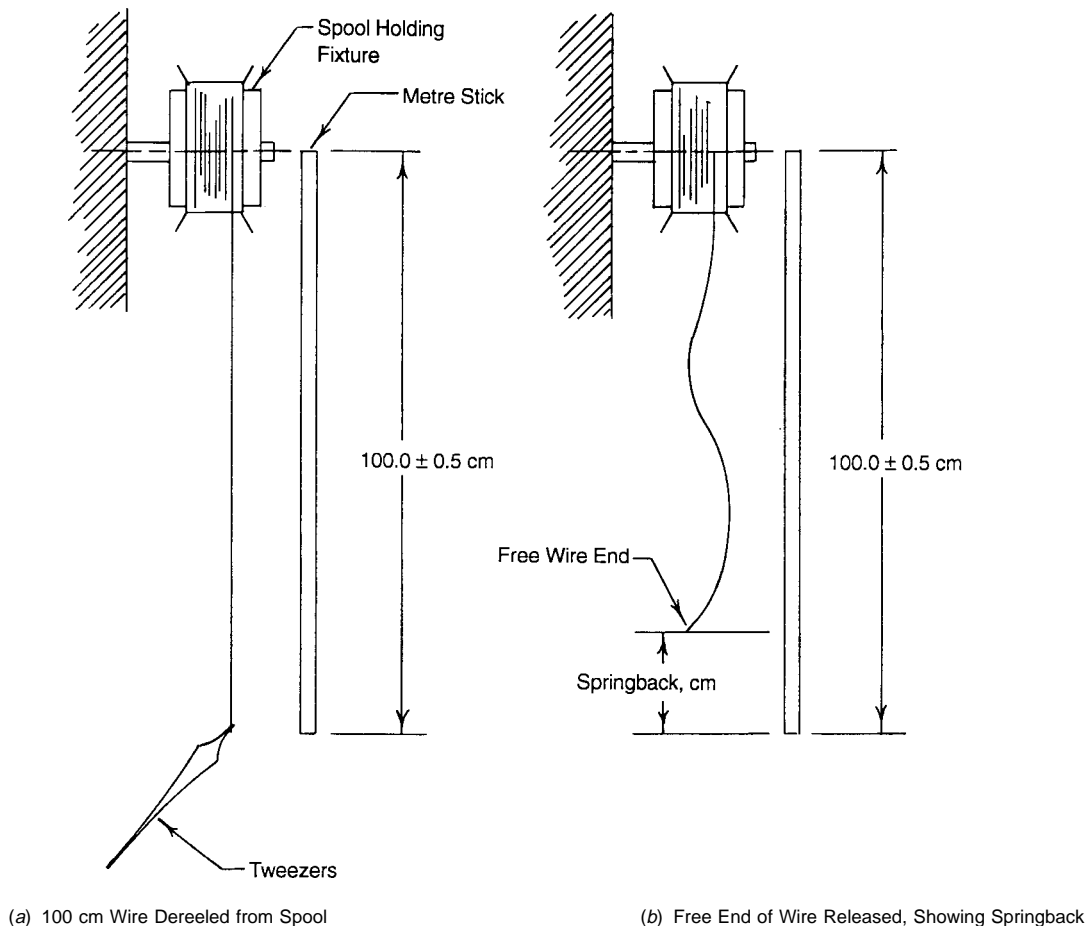
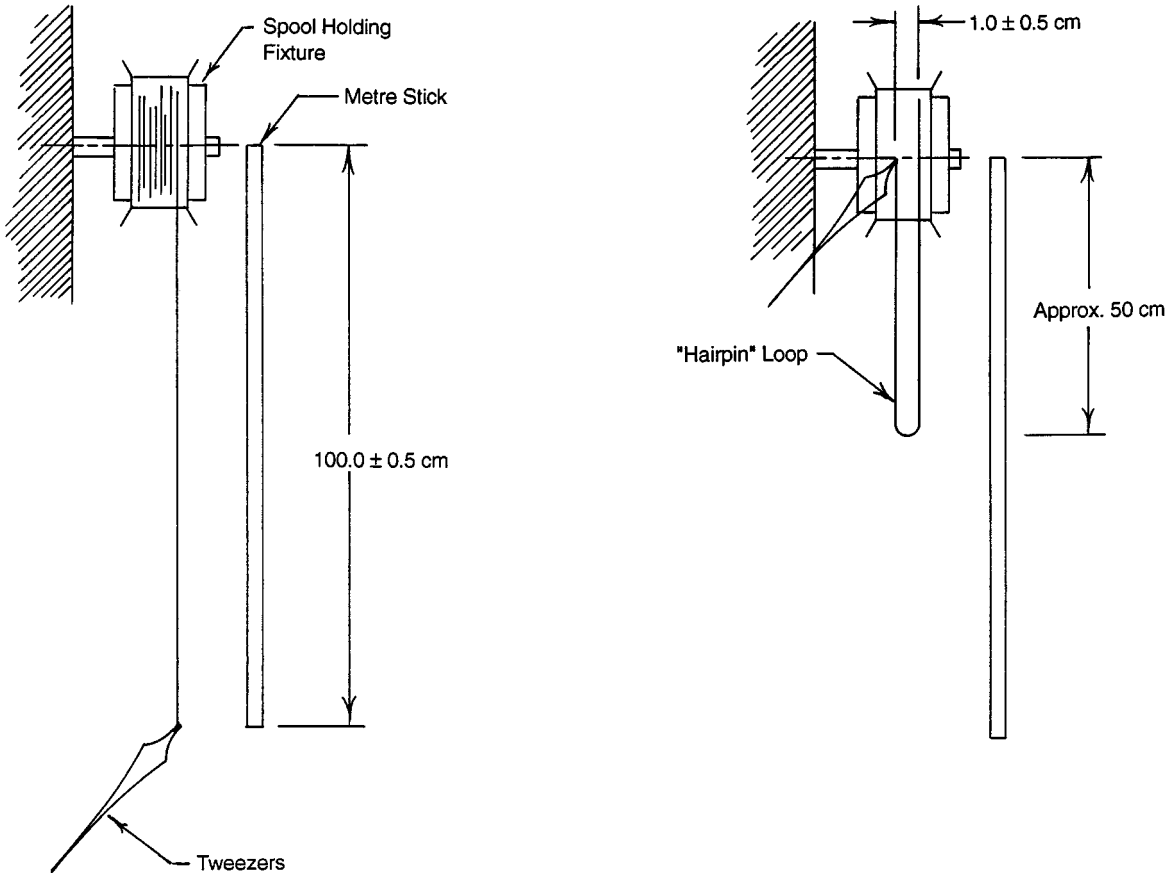

FIG. 1 Test Arrangement, Wire Curl Test



(a) 100 cm Wire Dereeled from Spool

(b) Wire Looped into "Hairpin," Illustrating Wire Free of Axial Twist

FIG. 2 Test Arrangement, Wire Axial Twist Test

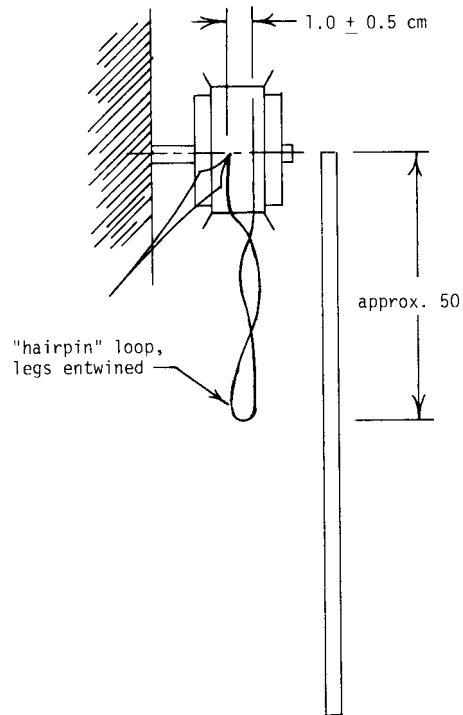

(c) Wire Looped into "Hairpin," Illustrating Wire Having Axial Twist

FIG. 2 Continued

9.6.5 Procedure:

9.6.5.1 Mount spool on fixture.

9.6.5.2 Using the tweezers, break the “starting end” wire end from its securing tab (Section 11). Gently pull the wire end, thus rotating the spool and dereeling the wire. Pulling force must not exceed 30 % of the wire breaking load. Pull the free wire end downward until 100 ± 0.5 cm of wire has been despoiled. Use the metre stick as a gage.

NOTE 5—**Caution:** Wire must be unwound from spool; the results of this test are invalid if the wire is despoiled “over the flange.” Likewise, operator must not rotate tweezers in such a way as to induce an axial twist in the wire.

9.6.5.3 Still grasping the wire end with the tweezers, gently lift the free wire end up to the spool forming a vertical “hairpin” loop 50 cm long, with its legs spaced 1 ± 5 cm apart. Hold the wire in this position a sufficient length of time to determine whether or not the wire is axially twisted.

9.6.5.4 Interpret the results of the test as follows: axial twist in the wire is indicated by entwining of the “hairpin” legs upon themselves; free hanging of the wire loop is indicative of the absence of axial twist.

9.7 Wire Roundness Test—The seller and the purchaser must agree on wire roundness test method. (Test methods for semiconductor lead-bonding wire roundness determination are under development in ASTM Subcommittee F01.07.)

10. Certification

10.1 When agreed upon in writing between the purchaser and the seller, a certification shall be made the basis of acceptance of the material. This shall consist of a copy of the manufacturer’s test report or a statement by the seller accompanied by a copy of the test results that the material has been sampled, tested, and inspected in accordance with the provisions of this specification. Each certification so furnished shall be signed by an authorized agent of the seller or the manufacturer.

11. Spooling

11.1 The wire shall be coiled either A-single layered, B-multilayered, cross-wound, or C-multilayered, parallel wound as illustrated in Fig. 3.

11.2 The wire shall be coiled on standard spools illustrated in Fig. 4, Fig. 5, Fig. 6, Fig. 7, Fig. 8, Fig. 9, Fig. 10, Fig. 11

and Table 12, as agreed upon between purchaser and seller.

11.3 The maximum and minimum length of wire on a spool shall be as specified by the purchaser.

11.4 The wire shall be wound so that it despoils freely and shall be free of kinks and nicks.

11.5 The beginning and end of the wind shall be clearly identified. The wire ends shall be secured with colored lacquer or adhesive; the starting end of unwind and the finish of unwind shall be clearly indicated on the package label.

11.6 Wire despooling is designated as either left-handed or right-handed unwind. Handedness of unwind shall be as specified by the purchaser.

11.6.1 The following procedure shall be used for determining the handedness of wire unwind:

11.6.1.1 This examination is intended to be nondestructive. Exercise extreme care in handling spools to prevent accidental wire damage. Do not detach the wire “starting end of unwind” from the spool in performing this test.

11.6.1.2 The test arrangement is illustrated schematically in Fig. 11. Refer to this figure in performing the steps that follow.

11.6.1.3 Select the spool to be tested. Hold the spool in one hand, or mount it on an appropriate fixture, so that the wire wrap is viewed at a comfortable distance at approximately eye level. Set the spool axis horizontal and perpendicular to the line of sight. Continue to use this viewing perspective in the steps which follow:

11.6.1.4 Orient the spool so that the wire’s “starting end of unwind” (11.5) points toward the operator from the top of the spool barrel.

11.6.1.5 Determine whether unwind would proceed from left to right, or conversely, from right to left across the spool barrel where the wire is to be despoiled.

11.6.2 *Left-Handed Unwind*—If despooling determined in 11.6.1.5 is from left to right the coiling is designated “left-handed unwind.”

11.6.3 *Right-Handed Unwind*—If despooling determined in 11.6.1.5 is from right to left, the coiling is designated “right-handed unwind.”

12. Packaging and Package Marking

12.1 Wire shall be protected against damage in normal handling and shipping, and the outer container shall bear markings indicating “fragile” contents, designating proper end

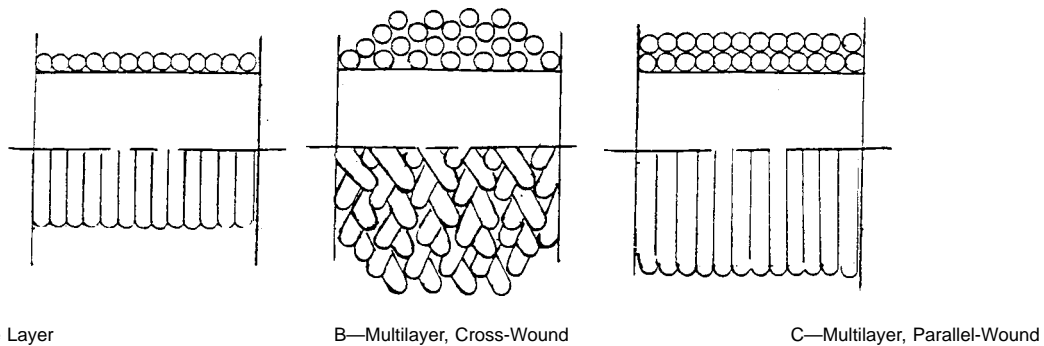

NOTE 1—In the three illustrations, the upper half of each spool depicts the cross-sectioned wire and the lower half depicts the wire as it appears wound on the spool.

FIG. 3 Spool Winding Options

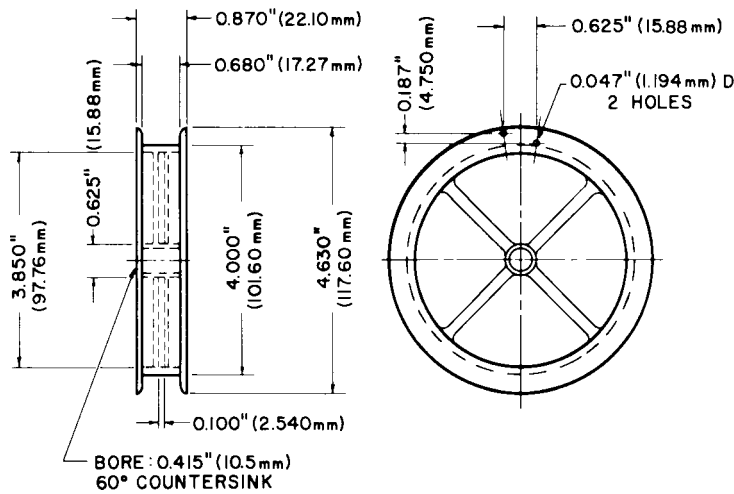
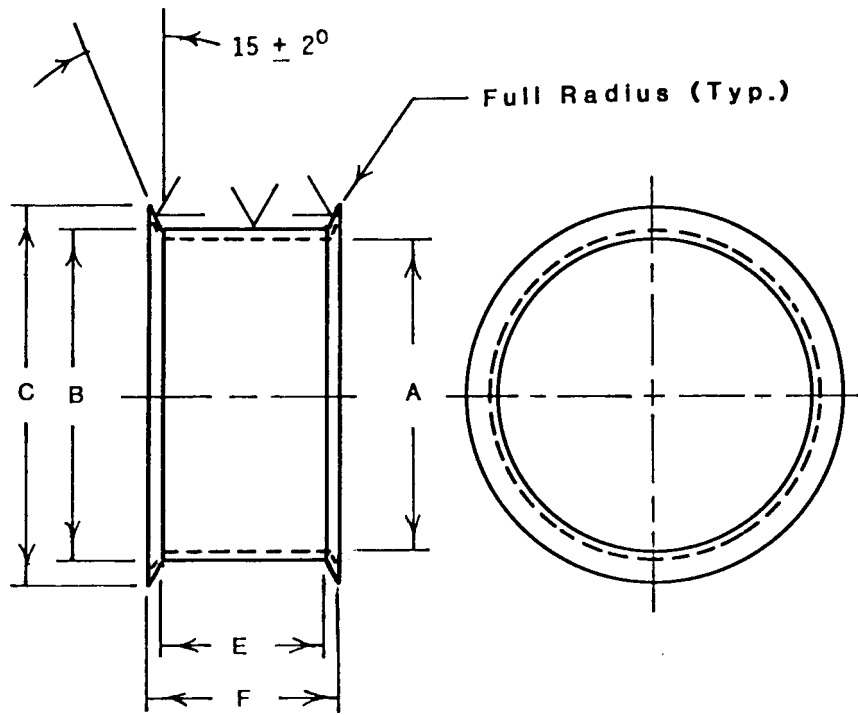

FIG. 4 Large Phenolic Plastic Spool



- NOTE 1—See Table 12.
 NOTE 2—Material—Aluminum.
 NOTE 3—Finish—Matte, anodized.
 NOTE 4—Break all edges.
 NOTE 5—Surfaces marked must be free of scratches, nicks, and other blemishes that would damage wire or hinder despooling.

FIG. 5 5-cm (2-in.) Diameter by 2.5-cm (1-in.) Wide Double-Flange Wire Spool

to be “up” in order to maintain spool axes horizontal during shipping, and indicate that extremes of temperature must be avoided.

12.2 The inner protective packages, enclosing individual spools, shall bear labels legibly carrying the following information:

- 12.2.1 Material description (beryllium- or copper-modified or high strength),
- 12.2.2 Diameter, μm (or in.),

- 12.2.3 Length of wire contained in package, m (or ft),
 - 12.2.4 Breaking load and percent elongation,
 - 12.2.5 Melt, bar, or lot number,
 - 12.2.6 Date of packaging,
 - 12.2.7 Indication of starting end of wire unwind,
 - 12.2.8 User’s part number, or purchase order number if no part number is designated on purchase contract, and
 - 12.2.9 Manufacturer’s name.
- 12.3 Special packaging and marking shall be agreed upon

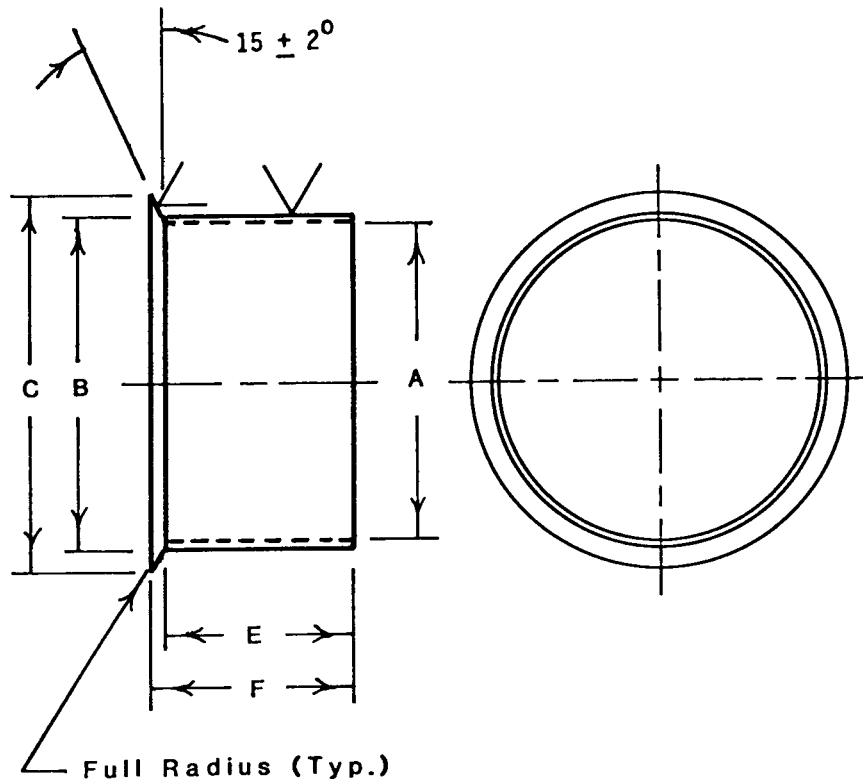

- NOTE 1—See Table 12.
- NOTE 2—Material—Aluminum.
- NOTE 3—Finish—Matte, anodized.
- NOTE 4—Break all edges.
- NOTE 5—Surfaces marked must be free of scratches, nicks, and other blemishes that would damage wire or hinder despooling.

FIG. 6 5-cm (2-in.) Diameter Single-Flange Wire Spool

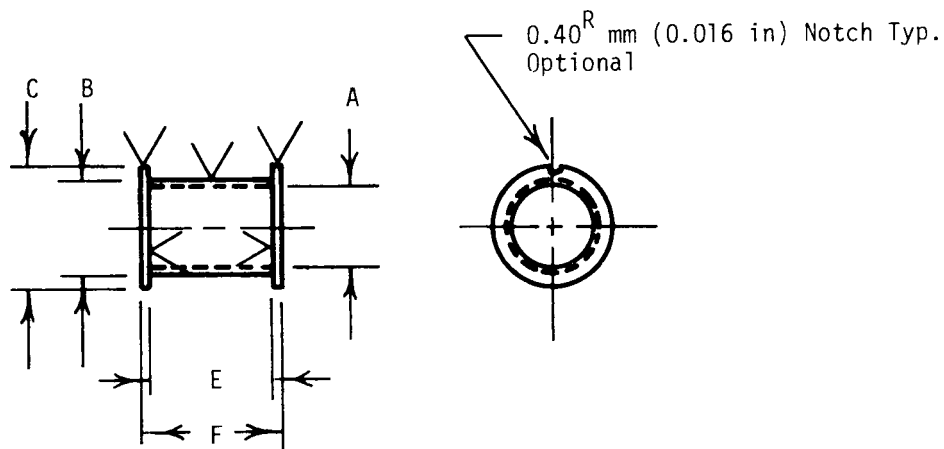

- NOTE 1—See Table 12.
- NOTE 2—Material—Aluminum.
- NOTE 3—Finish—Matte, anodized.
- NOTE 4—Break all edges.
- NOTE 5—Surfaces marked must be free of scratches, nicks, and other blemishes that would damage wire or hinder despooling.

FIG. 7 1.3-cm (1/2-in.) Diameter Wire Spool

between the purchaser and the seller.

12.4 The wire spools may be colored, or color-coded paint

dots or stickers may be attached to the spools, in order to designate the wire diameter. Any color code specification shall

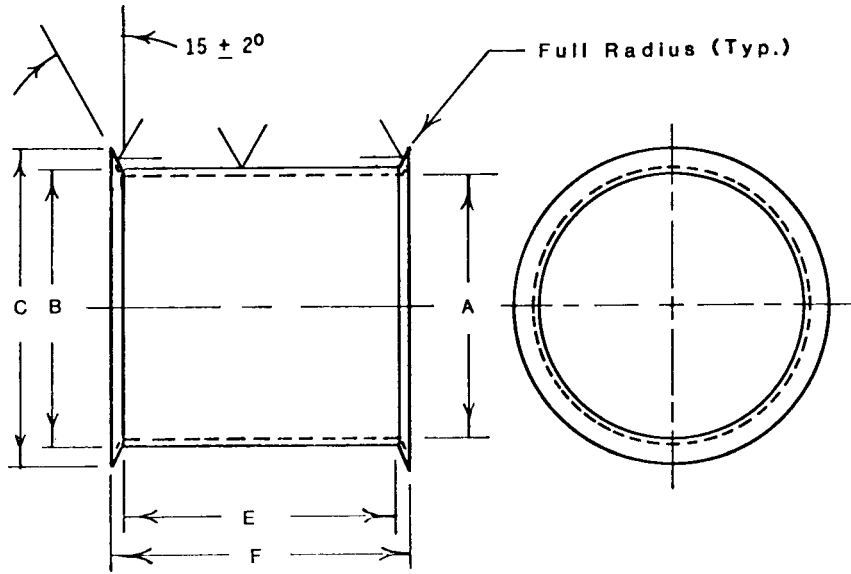

- NOTE 1—See Table 12.
- NOTE 2—Material—Aluminum.
- NOTE 3—Finish—Matte, anodized.
- NOTE 4—Break all edges.
- NOTE 5—Surfaces marked must be free of scratches, nicks, and other blemishes that would damage wire or hinder despooling.

FIG. 8 5-cm (2-in.) Diameter by 5-cm (2-in.) Wide Double-Flange Wire Spool

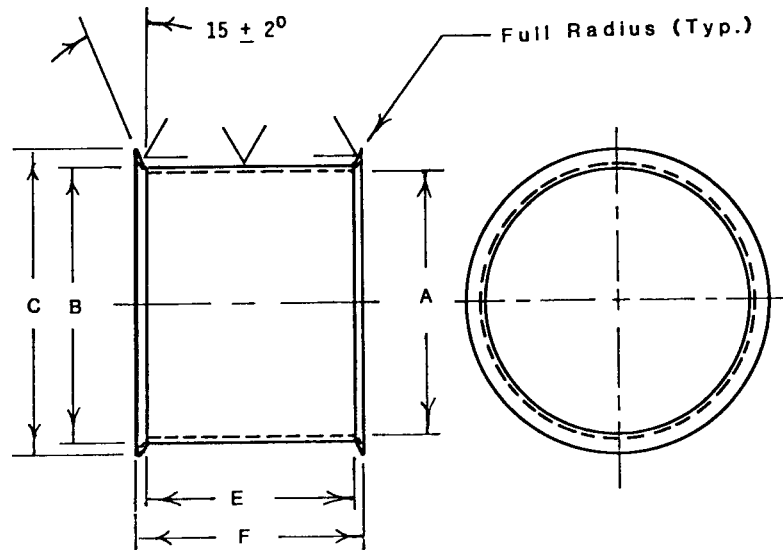

- NOTE 1—See Table 12.
- NOTE 2—Material—Aluminum.
- NOTE 3—Finish—Matte, anodized.
- NOTE 4—Break all edges.
- NOTE 5—Surfaces marked must be free of scratches, nicks, and other blemishes that would damage wire or hinder despooling.

FIG. 9 10-cm (4-in.) Diameter Double-Flange Wire Spool

be agreed upon between the purchaser and the seller.

NOTE 6—To encourage color code uniformity, the following diameter code is recommended:

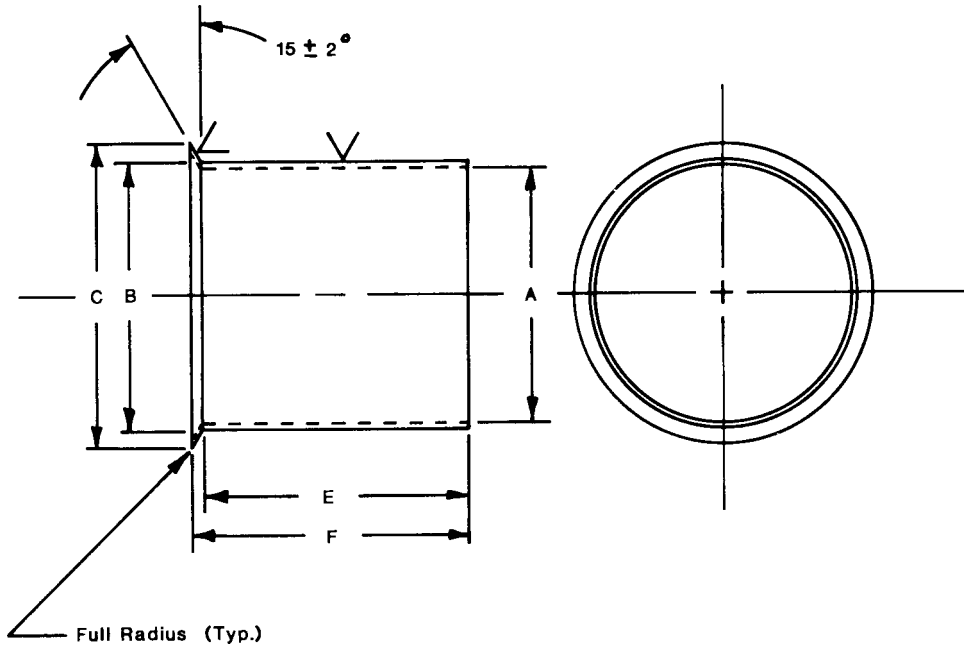

- NOTE 1—See Table 12.
- NOTE 2—Material—Aluminum.
- NOTE 3—Finish—Matte, anodized.
- NOTE 4—Break all edges.
- NOTE 5—Surfaces marked must be free of scratches, nicks, and other blemishes that would damage wire or hinder despooling.

FIG. 10 5-cm (2-in.) Diameter by 5-cm (2-in.) Wide Single-Flange Wire Spool

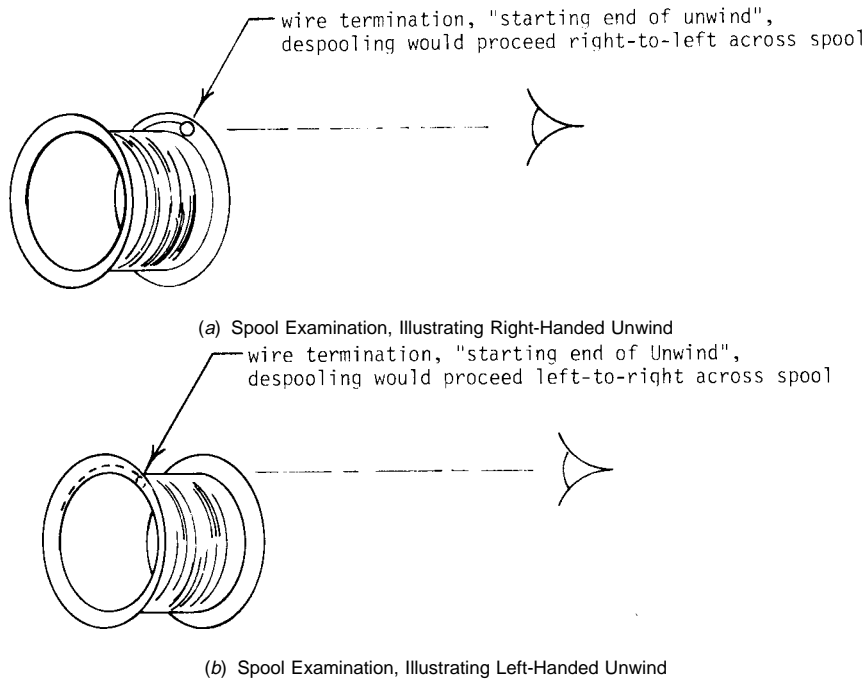

FIG. 11 Test Arrangement, Determination of Handedness of Wire Unwind

TABLE 12 Spool Dimensions

Spool Type	Figure	A Inside Diameter, mm (in.)	B Barrel Diameter, nominal, mm (in.)	C Flange Diameter, mm (in.)	E Barrel Width, mm (in.)	F Flange Width, reference, mm (in.)
F 72/B	7	12.7 ± 0.13 (0.500 ± 0.005) 49.02 + 0.51 - 0.00	13.5 (0.530) 50.3	17.4 ± 0.3 (0.687 ± 0.010) 56.90 ± 0.25	18.3 ± 0.3 (0.720 ± 0.010) 25.40 ± 0.13	19.1 (0.750) 28.19
F 72/G	5	1.930 + 0.020 - 0.000 48.31 + 0.01 - 0.00	(1.98) 50.3	(2.240 ± 0.010) 57.15 ± 0.25	(1.000 ± 0.005) 25.40 ± 0.13	(1.110) 28.83
F 72/H	5	1.902 + 0.005 - 0.000 49.02 + 0.51 - 0.00	(1.98) 50.3	(2.250 ± 0.010) 56.90 ± 0.25	(1.000 ± 0.005) 27.76 + 0.13 - 0.00	(1.135) 28.19
F 72/I	6	1.930 + 0.020 - 0.000 49.02 + 0.51 - 0.00	(1.98) 50.3	(2.240 ± 0.010) 56.90 ± 0.25	1.093 + 0.005 - 0.000 50.80 ± 0.26	(1.155) 53.59
F 72/J	8	1.930 + 0.020 - 0.000	(1.98)	(2.240 ± 0.010)	(2.000 ± 0.010)	(2.110)
F 72/K	9	100.48 ± 0.25 (3.956 ± 0.010) 49.02 + 0.51 - 0.00	101.6 (4.00) 50.3	111.25 ± 0.51 (4.380 ± 0.020) 56.90 ± 0.25	67.31 ± 0.25 (2.650 ± 0.010) 50.80 ± 0.26	80.01 (3.15) 53.59
F 72/L	10	1.93 + 0.020 - 0.000	(1.98)	(2.240 ± 0.010)	(2.000 ± 0.010)	(2.110)
F 72/M	9	100.48 ± 0.25 (3.956 ± 0.010)	101.6 (4.00)	111.25 ± 0.51 (4.380 ± 0.020)	76.2 ± 0.25 (3.00 ± 0.010)	80.01 (3.15)

Nominal Diameter, μm (in.)

13 (0.00050)
18 (0.00070)
20 (0.00080)
23 (0.00090)
25 (0.0010)
28 (0.0011)
30 (0.0012)
31.8 (0.00125)

Color

white
red
purple
brown
green
black
gray
blue

33 (0.0013)
38 (0.0015)
51 (0.0020)

yellow
orange
pink

12.4.1 Diameter color coding shall be separate from wire termination “start” and “end” color coding and shall not interfere with free despooling of wire.

APPENDIX

(Nonmandatory Information)

X1. SHELF LIFE AGING TEST 1983–1985

X1.1 Purpose

X1.1.1 To determine the effect of room temperature aging on the stress-strain characteristics of bonding wires of several compositions and tempers. (See Fig. X1.1 and Fig. X1.2.)

X1.2 Test parameters

X1.2.1 *Environment*— Typical stock room, 73°F, ±3°.

X1.2.2 *Spooling*—2-in. diameter, Aluminum, 100 ft/spool.

X1.2.3 *Instrument*— Instron type, 1 in./min, 10 in. length.

X1.2.4 *Sampling*—Average of five readings per notation.

X1.2.5 *Time*—Intervals shown on charts.

X1.2.6 *Wire Size*—All specimens, 0.001 in. diameter.

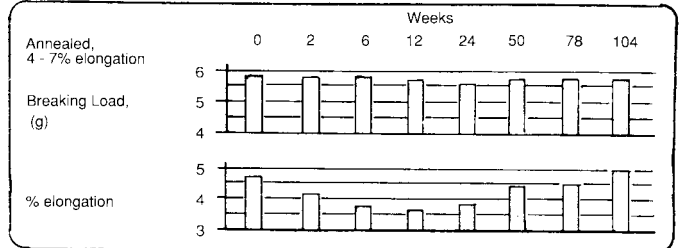
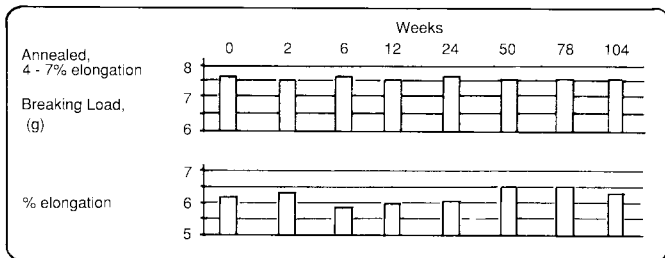
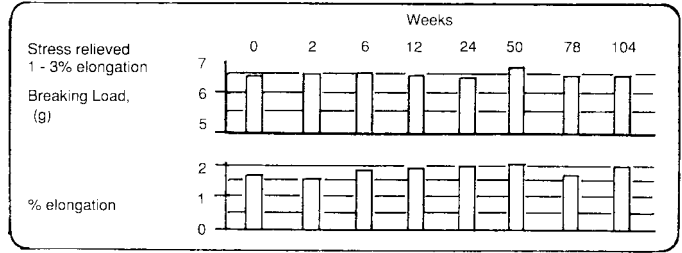
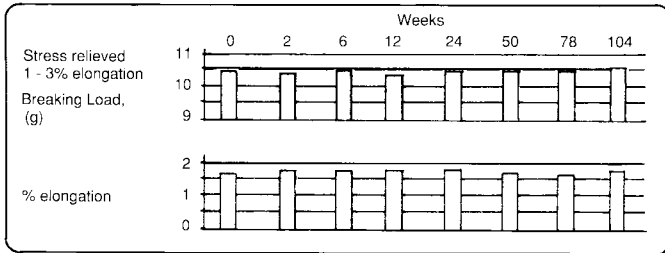
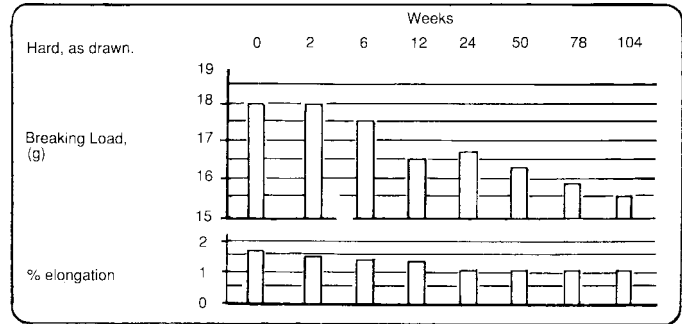
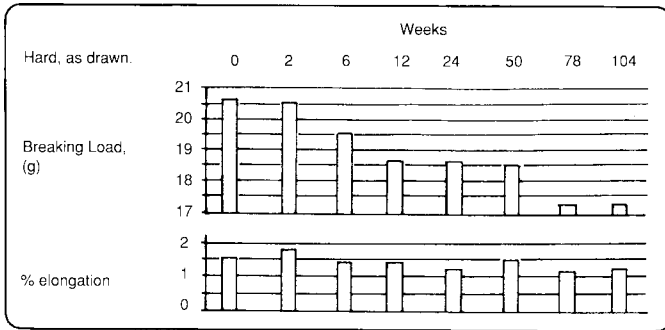

FIG. X1.1 Chart 1 99.99 % Gold + Beryllium

FIG. X1.2 Chart 2 99.99 % Gold + Copper

The American Society for Testing and Materials takes no position respecting the validity of any patent rights asserted in connection with any item mentioned in this standard. Users of this standard are expressly advised that determination of the validity of any such patent rights, and the risk of infringement of such rights, are entirely their own responsibility.

This standard is subject to revision at any time by the responsible technical committee and must be reviewed every five years and if not revised, either reapproved or withdrawn. Your comments are invited either for revision of this standard or for additional standards and should be addressed to ASTM Headquarters. Your comments will receive careful consideration at a meeting of the responsible technical committee, which you may attend. If you feel that your comments have not received a fair hearing you should make your views known to the ASTM Committee on Standards, at the address shown below.

This standard is copyrighted by ASTM, 100 Barr Harbor Drive, PO Box C700, West Conshohocken, PA 19428-2959, United States. Individual reprints (single or multiple copies) of this standard may be obtained by contacting ASTM at the above address or at 610-832-9585 (phone), 610-832-9555 (fax), or service@astm.org (e-mail); or through the ASTM website (www.astm.org).