



Designation: F 816 – 83 (Reapproved 1998)^{ε1}

AMERICAN SOCIETY FOR TESTING AND MATERIALS
100 Barr Harbor Dr., West Conshohocken, PA 19428
Reprinted from the Annual Book of ASTM Standards. Copyright ASTM

Standard Test Method for Combined Fine and Gross Leaks for Large Hybrid Microcircuit Packages¹

This standard is issued under the fixed designation F 816; the number immediately following the designation indicates the year of original adoption or, in the case of revision, the year of last revision. A number in parentheses indicates the year of last reapproval. A superscript epsilon (ϵ) indicates an editorial change since the last revision or reapproval.

^{ε1} NOTE—Editorial changes made throughout in May 1998.

1. Scope

1.1 This test method applies to hermetic package leak testing to detect leaks of a broad spectrum in size with a minimum detection level equal to the sensitivity of the helium mass spectrometer equipment used in the test.

1.2 *This standard does not purport to address all of the safety concerns, if any, associated with its use. It is the responsibility of the user of this standard to establish appropriate safety and health practices and determine the applicability of regulatory limitations prior to use.*

2. Referenced Documents

2.1 ASTM Standards:

E691 Practice for Conducting an Interlaboratory Study to Determine the Precision of a Test Method²

F78 Test Method for Calibration of Helium Leak Detectors by Use of Secondary Standards³

F98 Practices for Determining Hermeticity of Electron Devices by a Bubble Test⁴

F134 Test Methods for Determining Hermeticity of Electron Devices with a Helium Mass Spectrometer Leak Detector⁵

2.2 Federal Standard:

Federal Standard 209B Clean Room and Work Station Requirements, Controlled Environment⁶

3. Summary of Method

3.1 This test method for the hermeticity of packages used for housing multichip and hybrid microcircuits is to be applied generally to those equal to or greater than 1 in.² (645 mm²) in area or 0.60 cm³ in volume. A vent hole (See Fig. 1) is designed into the lid of the package. After sealing the lid on the package, the vent hole in the lid is presented to a port in the inlet of the

helium leak detector using an interface seal (See Fig. 2). After the internal volume is evacuated, a cloud of helium gas is brought into close proximity to the entire outer surface of the package. Helium passing into the inner volume of the package through any leak orifice in an amount greater than the minimum sensitivity of the leak detector will be detected within a few seconds. The successfully sealed product is then placed into a controlled atmosphere dry box for vacuum purging and back filling the internal volume of the package through the vent hole with an inert gas having some detectable partial pressure level of helium gas. While under this latter condition, the vent hole is sealed off by a suitable manner. The specimen is then immediately retested by the above method to detect successful sealing of the vent hole.

4. Significance and Use

4.1 This test method provides an evaluation of the quality of an in-line sealing process on a real time basis for sealed packages. It eliminates the need to expose the specimen to long exposures of high pressure to drive the helium gas into the package to later be detected by the same method herein used. Previously, separate test methods were required to detect large or small leaks. This method provides only one test to accomplish all test levels without potential for specimens with leaks to escape detection within the range of detection being employed (see Practices F 98).

4.2 Both development and research, along with manufacturing control, may be served by using this test method. Current gross leak test methods and fine leak test methods may be combined into one using this method. No exposure to high pressure processing hazards is involved and safety of operation in production environment is enhanced.

5. Interferences

5.1 The use of the helium leak detector requires a specific gas transit time for the helium to pass through a leak orifice in the specimen and travel into the mass spectrometer sensing element for detection. The value of this time constant should be exceeded for all test conditions to be considered valid. For small leaks, the time constant will be maximum. Allowing the helium gas to bathe the specimen for a time in excess of this time constant will suffice. This time constant should normally

¹ This test method is under the jurisdiction of ASTM Committee F-1 on Electronics and is the direct responsibility of Subcommittee F01.03 on Metallic Materials.

Current edition approved May 27, 1983. Published July 1983.

² *Annual Book of ASTM Standards*, Vol 14.02.

³ *Annual Book of ASTM Standards*, Vol 10.04.

⁴ Discontinued; see *1990 Annual Book of ASTM Standards*, Vol 10.04.

⁵ Discontinued; see *1996 Annual Book of ASTM Standards*, Vol 10.04.

⁶ Available from Standardization Documents Order Desk, Bldg. 4 Section D, 700 Robbins Ave., Philadelphia, PA 19111-5094, Attn: NPODS.

ASTM F 816

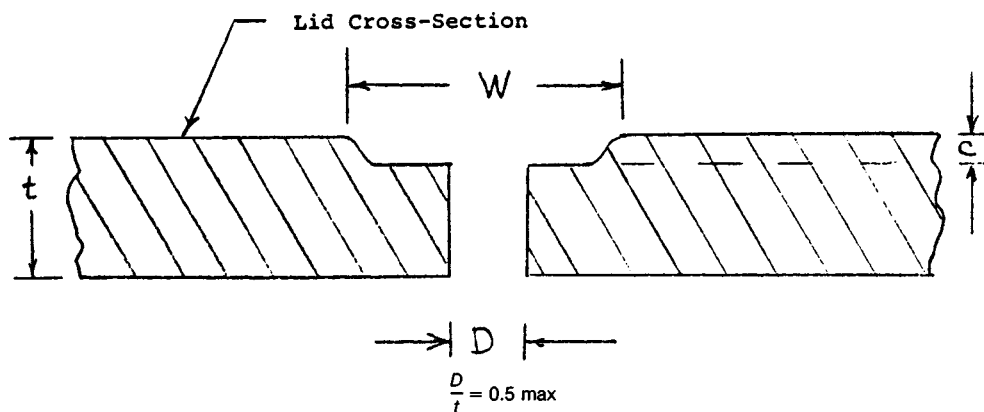

$D_{\text{max}} = 0.51 \text{ mm (0.02 in.)}$, typically $0.018 \pm 0.002 \text{ in.}$

$W_{\text{min}} = 2D \text{ to } 3D$

$C = 0.008W \text{ to } 0.1W$

$t = 0.25 \text{ to } 1.02 \text{ mm}$, typically $0.01 \text{ to } 0.04 \text{ in.}$

FIG. 1 Lid Vent Hole Design Option

be no longer than 5 s.

5.2 Any contaminating films or seal defects in the interface between the apparatus port and the vent hole in the lid of the package may indicate a false leak. Adequate handling, cleanliness, and operator performance to ensure the integrity of this interface seal is necessary.

5.3 When a large leak is encountered that allows a large charge of helium gas to enter the mass spectrometer, it may be necessary to allow the system to regain a normal (unsaturated) condition before proceeding.

6. Apparatus

6.1 See Test Methods F 134 for helium leak detector test apparatus.

6.2 See Fed. Std. No. 209B.

6.3 See Fig. 2 for a sketch of manifold for specimen interface with leak detector and helium cup enclosure. The elastomer seal material may be made of butyl rubber, neoprene, or fluorocarbon rubber (Viton) depending on the desired compression force being used. The O-ring squeeze should be about 0.2 mm to assure a tight seal on a dry surface.

6.4 The dry box in which the vent hole is sealed may either be provided with a soldering iron or a spot welding head depending upon which method of seal is selected. The dry box shall also be provided with an adequate flow of dry nitrogen or some other inert gas to which can be added up to 10 % by volume of helium gas. A tube connected to a vacuum source shall be available inside the dry box for purging the specimens prior to sealing the vent hole. When spot welding is used to close the vent hole, it will be necessary to supply a thin disk of suitable material to cover over the vent hole and an appropriately sized welding fixture for weld sealing the disk over the vent hole.

7. Reagents and Materials

7.1 Helium Gas Source, commercially pure.

7.2 Inert Gas Source, nitrogen gas commercially pure.

7.3 Cleaning Solutions/Solvents.

7.4 Soft Solder and Soldering Iron.

8. Sampling

8.1 No specific sampling plan is to be implied by the use of this test method. The user is encouraged to adopt this method for 100 % testing of production product.

9. Preparation of Apparatus

9.1 Prepare apparatus in accordance with Test Methods F 134.

10. Calibration of Apparatus

10.1 Calibrate apparatus in accordance with Test Method F 78.

11. Procedure

11.1 Place each specimen to be tested on the test port (Note 1), one to each port for multiport manifold apparatus designs, with the vent hole centered on the interface seal surface location.

NOTE 1—A background or tare reading may be taken for each package style (plating) by rotating it 180° so the seal surface location is covered by a portion of the package lid that does not have a vent hole. This establishes a measurement threshold value for each package style and lid plating material.

11.2 Vent the leak test apparatus to evacuation mode by opening Valve A (See Fig. 2).

11.3 Place a helium cloud chamber shroud over the specimen(s) (common or singular units).

11.4 Observe the evacuation pressure to determine that it is normal.

11.5 If it is not normal (equal to the closed port value), inspect for a malfunction of the interface seal to the manifold. Correct any defects before proceeding.

11.6 Set the sensitivity scale of the leak detector to the scale required by the test parameter specification.

11.7 When the helium leak detector apparatus reached a condition of readiness to detect a helium source, momentarily

ASTM F 816

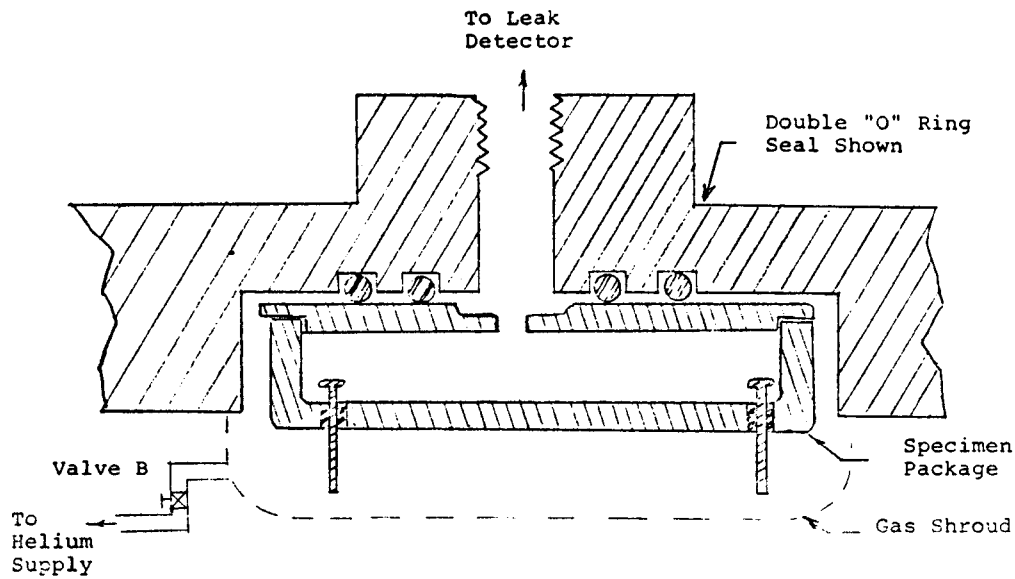

(a) Port Inlet Detail

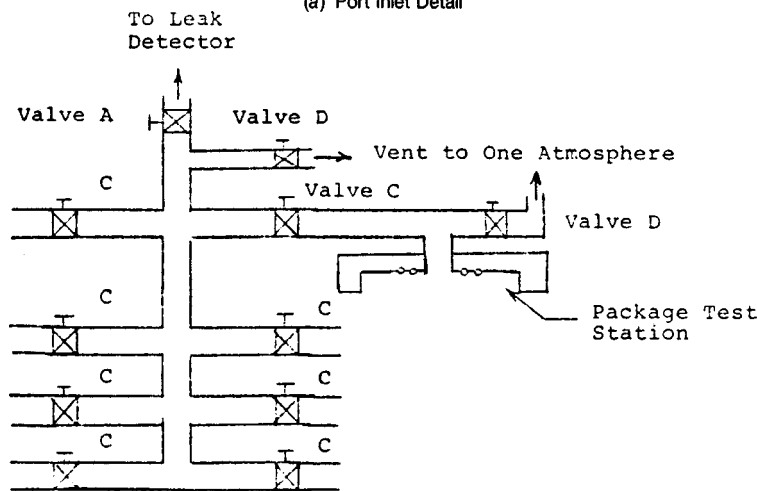

(b) 8 Station Package Manifold Apparatus

FIG. 2 Port Inlet to Leak Detector and Manifold Design

open Valve B to the supply of helium gas to the cover shroud, to allow flooding of the specimen surface with helium.

11.8 Observe the visual and audible indicators of the leak detector for a signal.

11.9 If a plurality of specimens are to be measured in sequence, repeat 11.7 and 11.8 for each specimen in turn.

11.10 If a plurality of specimens are to be tested in unison, open Valve C to the common manifold apparatus and flood all units simultaneously.

11.10.1 Determine if any leaks occur. If none are present, complete the test record to certify test completion.

11.10.2 If a leak is detected in 11.10, repeat the test on one-half the specimens followed by a like test of the other half of the specimens.

11.10.3 Continue the test sequence of 11.10.1 and 11.10.2 until all of the leaking specimens have been detected on an individual basis.

NOTE 2—An alternative to the procedures in 11.10.2 is to singularly test one specimen at a time until all the failures are detected.

11.11 Upon completion of the test on all specimens, record the results as appropriate.

11.12 Proceed to remove the specimens from the apparatus. Sequential closing of the valves to the leak detector is followed by venting the specimens to one atmosphere of dry gas by opening Valve D.

11.13 *Vent Hole Sealing:*

11.13.1 Perform an elevated temperature vacuum bake-out on all specimens at 125°C for at least 2 h. Maintain an oil-vapor-free pressure of 1 Pa or less in the vacuum oven for this preconditioning step.

11.13.2 Transfer the specimens from the vacuum-oven to the dry box in 11.13.3 through a dry-inert gas ambient.

11.13.3 Place the specimens in the dry box for seal of the vent hole.

NOTE 3—When the inert gas in the dry box includes 10 % helium, then any subsequently measured leakage rate must be increased by a factor of ten to obtain the actual value because of the reduced initial partial pressure of helium.

 **F 816**

11.13.4 Apply the vacuum port to the vent hole for 3 to 5 s, remove it to allow the inert gas to enter, then repeat for 5 to 10 more cycles ending with the backfill step.

11.13.5 Apply soft solder and heat to close the vent hole in a rapid single pass stroke act when solder sealing or spot weld the thin disk in place over the vent hole.

11.13.6 Repeat 11.1 through 11.8 or through 11.12, as appropriate to, determine if the vent hole closure is secure (no detectable leaks), omitting 11.7.

11.14 Record the results.

11.15 Any failures in 11.13.6 should be treated to a desoldering of the vent hole inside the dry box and the resealing attempted a second time followed by a retest of the vent hole seal integrity.

12. Precision and Bias

12.1 The precision and bias of this test method is to be determined through an interlaboratory test program conducted

in accordance with Practice E 691. Although this test method uses a detecting method which has an established precision and bias as stated in Test Method F 78, it is possible that the interconnection manifold portion of the apparatus may contribute to some inaccuracies controllable only by the performing laboratory. In this case, the within-laboratory precision index will vary significantly from the normal of the interlaboratory index. In the case of this obvious condition, an allowance to correct the condition with a retest is indicated, or the suspect data should be ruled invalid.

12.2 Wherein a criteria for successful pass or fail limit is defined in the test specification, no other statement of precision and bias is necessary beyond that expressed in Test Method F 78.

13. Keywords

13.1 helium leak check; hermetic packages; hybrid micro-circuits

ANNEX

(Mandatory Information)

A1. DESIGN OF VENT HOLE IN LID

A1.1 The purpose of the vent hole is to provide for venting helium gas from the internal volume of the package into the leak detector in the initial test. It is designed with a coined step to provide a well structure in combination with the small through-hole so as to provide a retaining force on the melted solder through the surface tension forces to prevent intrusion of the solder into a droplet on the inside of the package while it is molten. Any attempt to deviate from this concept will cause a high risk of a solder droplet being included as a loose particle inside the sealed package.

A1.2 Forming a hole with the geometry shown in Fig. 1 may be accomplished using a single-tooling or a two-step tooling operation.

A1.2.1 The single-tooling step requires the use of a jeweler's staking tool set or equivalent. This provides a round face

punch with a piercing center and a matching stump die. When the punch is impacted into the lid, the coining of the surface and the punching of the hole occur simultaneously.

A1.2.2 The two-step tooling operation is accomplished using a coining die set to first put the dimple into the lid. This is followed by a hole punch-out die set operation which removes the volume of material to form the hole in a pneumatic impact punch or equivalent motion.

A1.3 *Hole Location*—It is recommended that the vent hole location in the lid be placed in the same quadrant in which Pin No. 1 is located when the lid is located on the package. This will provide additional standardization to the use of this method and to the identification marking system for electronic device enclosures.

The American Society for Testing and Materials takes no position respecting the validity of any patent rights asserted in connection with any item mentioned in this standard. Users of this standard are expressly advised that determination of the validity of any such patent rights, and the risk of infringement of such rights, are entirely their own responsibility.

This standard is subject to revision at any time by the responsible technical committee and must be reviewed every five years and if not revised, either reapproved or withdrawn. Your comments are invited either for revision of this standard or for additional standards and should be addressed to ASTM Headquarters. Your comments will receive careful consideration at a meeting of the responsible technical committee, which you may attend. If you feel that your comments have not received a fair hearing you should make your views known to the ASTM Committee on Standards, 100 Barr Harbor Drive, West Conshohocken, PA 19428.