



Designation: F 847 – 94 (Reapproved 1999)

## Standard Test Methods for Measuring Crystallographic Orientation of Flats on Single Crystal Silicon Wafers by X-Ray Techniques<sup>1</sup>

This standard is issued under the fixed designation F 847; the number immediately following the designation indicates the year of original adoption or, in the case of revision, the year of last revision. A number in parentheses indicates the year of last reapproval. A superscript epsilon ( $\epsilon$ ) indicates an editorial change since the last revision or reapproval.

### 1. Scope

1.1 These test methods cover the determination of  $\alpha$ , the angular deviation between the crystallographic orientation of the direction perpendicular to the plane of a fiducial flat on a circular silicon wafer, and the specified orientation of the flat in the plane of the wafer surface.

1.2 These test methods are applicable for wafers with flat length values in the range of those specified for silicon wafers in SEMI Specification M 1. They are suitable for use only on wafers with angular deviations of less than  $\pm 5^\circ$ .

1.3 The orientation accuracy achieved by these test methods depends directly on the accuracy with which the flat surface can be aligned with a reference fence and the accuracy of the orientation of the reference fence with respect to the X-ray beam.

1.4 Two test methods are covered as follows:

	Sections
Test Method A—X-Ray Edge Diffraction Method	8 to 13
Test Method B—Laue Back Reflection X-Ray Method	14 to 18

1.4.1 Test Method A is nondestructive and is similar to Test Method A of Test Methods F 26 except that it uses special wafer holding fixtures to orient the wafer uniquely with respect to the X-ray goniometer. The technique is capable of measuring the crystallographic direction of flats to a greater precision than the Laue back reflection method.

1.4.2 Test Method B is also nondestructive, and is similar to Test Method E 82, and to DIN 50 433, Part 3, except that it uses “instant” film and special fixturing to orient the flat with respect to the X-ray beam. Although it is simpler and more rapid, it does not have the precision of Test Method A because it uses less precise and less expensive fixturing and equipment. It produces a permanent film record of the test.

NOTE 1—The Laue photograph may be interpreted to provide information regarding the crystallographic directions of wafer misorientation; however, this is beyond the scope of the present test method. Users desiring to carry out such interpretation should refer to Test Method E 82

and to DIN 50 433, Part 3, or to a standard X-ray textbook.<sup>2,3</sup> With different wafer holding fixturing, Test Method B is also applicable to determination of the orientation of a wafer surface.

1.5 The values stated in inch-pound units are to be regarded as the standard. The values given in parentheses are for information only.

1.6 *This standard does not purport to address all of the safety concerns, if any, associated with its use. It is the responsibility of the user of this standard to establish appropriate safety and health practices and determine the applicability of regulatory limitations prior to use.* For specific hazard statements see Section 6.

### 2. Referenced Documents

#### 2.1 ASTM Standards:

E 82 Test Method for Determining the Orientation of a Metal Crystal<sup>4</sup>

E 122 Practice for Choice of Sample Size to Estimate a Measure of Quality for a Lot or Process<sup>5</sup>

F 26 Test Methods for Determining the Orientation of a Semiconductive Single Crystal<sup>6</sup>

#### 2.2 Military Standard:

MIL-STD-105D Sampling Procedures and Tables for Inspection by Attributes<sup>7</sup>

#### 2.3 Other Standards:

Code of Federal Regulations, Title 10, Part 20, Standards for Protection Against Radiation<sup>8</sup>

SEMI Specification M 1, Polished Monocrystalline Silicon Slices<sup>9</sup>

DIN 50 433, Part 3, Testing of Materials for Semiconductor

<sup>2</sup> Wood, E. A., *Crystal Orientation Manual*, Columbia University Press, New York, NY, 1963.

<sup>3</sup> Barret, C. S., and Massalski, T. B., *The Structure of Metals*, 3rd edition McGraw-Hill, New York, NY, 1966.

<sup>4</sup> *Annual Book of ASTM Standards*, Vol 03.01.

<sup>5</sup> *Annual Book of ASTM Standards*, Vol 14.02.

<sup>6</sup> *Annual Book of ASTM Standards*, Vol 10.05.

<sup>7</sup> Available from Standardization Documents Order Desk, Bldg. 4 Section D, 700 Robbins Ave., Philadelphia, PA 19111-5094, Attn: NPODS.

<sup>8</sup> Published in Federal Register, Nov. 16, 1960. Available from Superintendent of Documents, U.S. Government Printing Office, Washington, DC 20402.

<sup>9</sup> Available from the Semiconductor Equipment and Materials Institute, Inc., 805 E. Middlefield Rd., Mountain View, CA 94043.

<sup>1</sup> These test methods are under the jurisdiction of ASTM Committee F01 on Electronics and are the direct responsibility of Subcommittee F01.06 on Silicon Materials and Process Control.

Current edition approved Aug. 15, 1994. Published October 1994. Originally published as F847 – 83. Last previous edition F847 – 87.

**WAFER HOLDING FIXTURE**

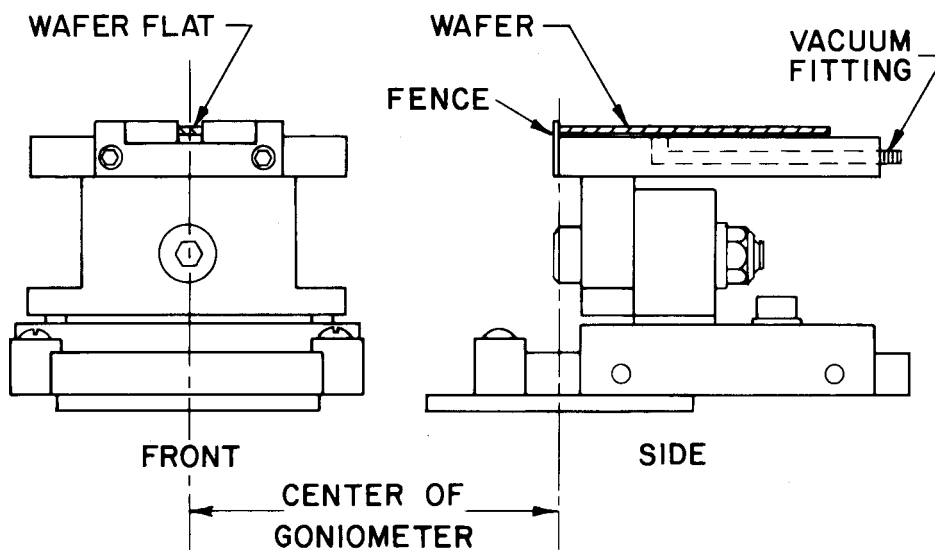

(a) Front and Side Views

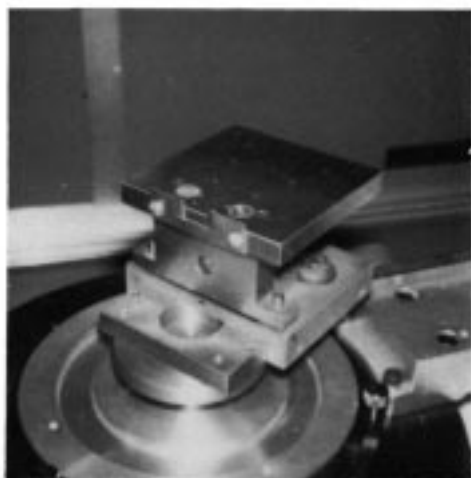

(b) Photograph of Mounted Fixture

**WAFER REFERENCE FENCE**

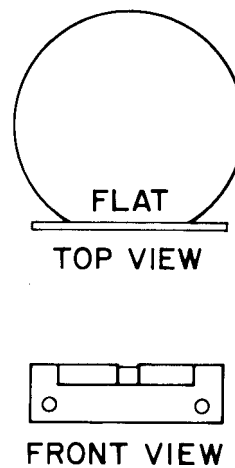

(c) Detail of Wafer and Reference Fence

**FIG. 1 Wafer Holding Fixture for X-Ray Edge Diffraction Method**

Technology: Determining the Orientation of Single Crystals Using the Laue Back-Scattering Method<sup>6,10</sup>

**3. Terminology**

3.1 *Definitions of Terms Specific to This Standard:*

3.1.1 *orientation*—of a single crystal surface, the crystallographic plane, described in terms of its Miller indices, with which the surface is ideally coincident. The orientation of a wafer flat is the orientation of the surface of the flat (on the edge of the wafer). Flats are usually specified with respect to a

low-index plane, such as a {110} plane. In such cases the orientation of the flat may be described in terms of its angular deviation from the low-index plane.

**4. Significance and Use**

4.1 The orientation of flats on silicon wafers is an important materials acceptance requirement. The flats are used in semiconductor device processing to provide consistent alignment of device geometries with respect to crystallographic planes and directions.

4.2 Either one of these test methods is appropriate for process development and quality assurance applications. Until the interlaboratory precision of these test methods has been

<sup>10</sup> Available from Beuth Verlag GmbH Burggrafenstrasse 4-10, D-1000 Berlin 30, Germany.

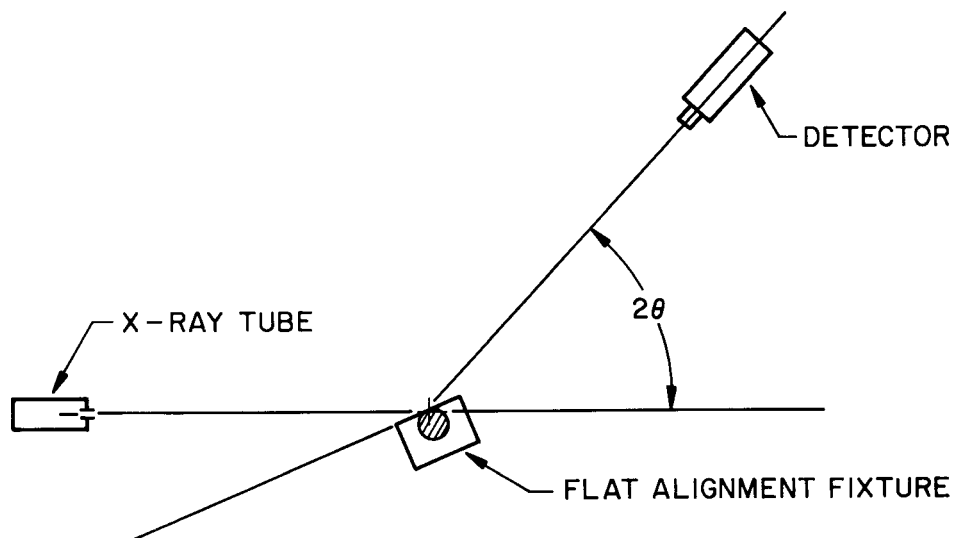

FIG. 2 Schematic of the Diffraction Geometry for the X-Ray Edge Diffraction Method

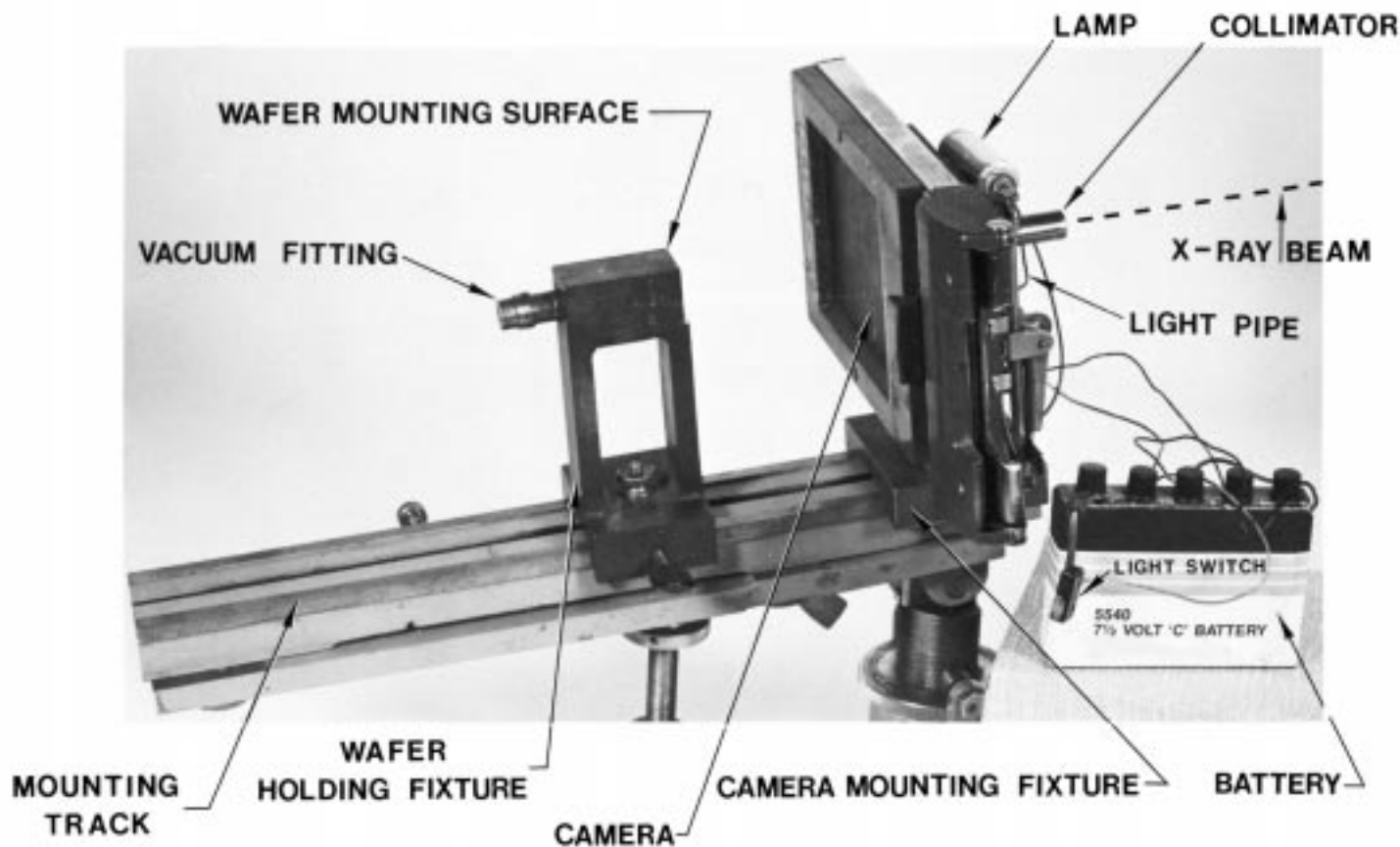

FIG. 3 Photograph of Assembled View of Laue Camera and Wafer Holder

determined, it is not recommended that they be used between supplier and purchaser.

### 5. Interferences

5.1 The alignment of the flat against the reference fence may be affected by the straightness of the flat. In the unlikely event that the flat profile is convex, the flat orientation may not

be unique. More often the flat surface will touch the reference fence along two lines perpendicular to the wafer surface at two points. In this case, the orientation determined will be that of the plane through the two lines on the plane perpendicular to the wafer surface which passes through the two points. In the latter cases, the orientation determined is that which will be

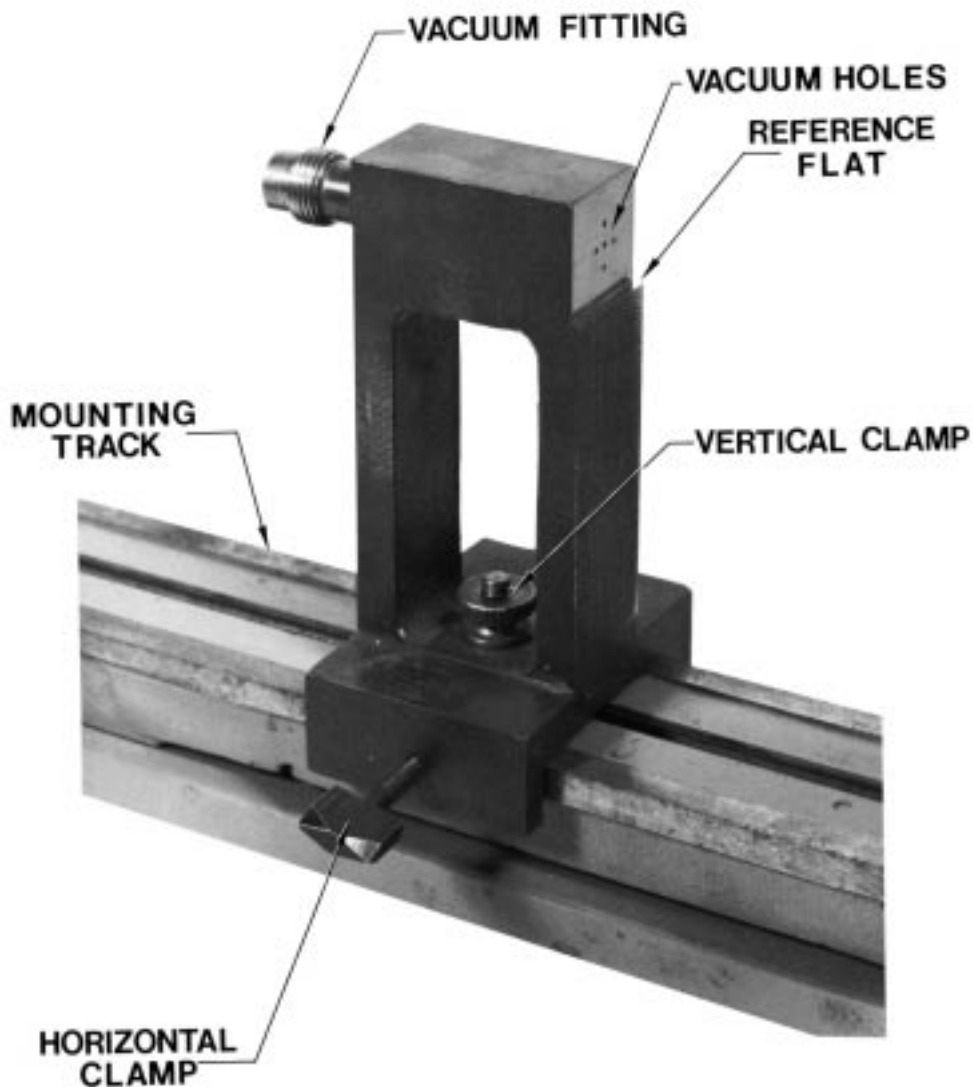

FIG. 4 Photograph of Wafer Holding Fixture and Mounting Track

obtained in subsequent processing of the wafer when the alignment is between the flat and a reference fence.

5.2 Misalignment of the various fixtures will degrade both the interlaboratory reproducibility and the absolute accuracy of both test methods. The single-instrument repeatability will not be degraded provided the fixturing is rigid.

## 6. Hazards

6.1 These test methods use X-radiation; it is absolutely necessary to avoid personal exposure to X rays. It is especially important to keep hands or fingers out of the path of the X rays and to protect the eyes from scattered secondary radiation. The use of commercial film badge or dosimeter service is recommended, together with periodic checks of the radiation level at the hand and body positions with a Geiger-Muller counter calibrated with a standard nuclear source. The present maximum permissible dose for total body exposure of an individual

to external X-radiation of quantum energy less than 3 MeV over an indefinite period is 1.25 R ( $3.22 \times 10^{-4}$  C/kg) per calendar quarter (equivalent to 0.6 mR/h ( $1.5 \times 10^{-7}$  C/kg-h)) as established in the *Code of Federal Regulations*, Title 10, Part 20. The present maximum permissible dose of hand and forearm exposure under the same conditions is 18.75 R ( $4.85 \times 10^{-3}$  C/kg) per calendar quarter (equivalent to 9.3 mR/h ( $2.4 \times 10^{-6}$  C/kg-h)). Besides the above stated regulations, various other government and regulatory organizations have their own safety requirements. It is the responsibility of the user to make sure that the equipment and the conditions under which it is used meet these regulations.

## 7. Sampling

7.1 Unless otherwise specified, Practice E 122 shall be used. When so specified, appropriate sample sizes shall be selected from each lot according to MIL-STD-105D. Inspection levels

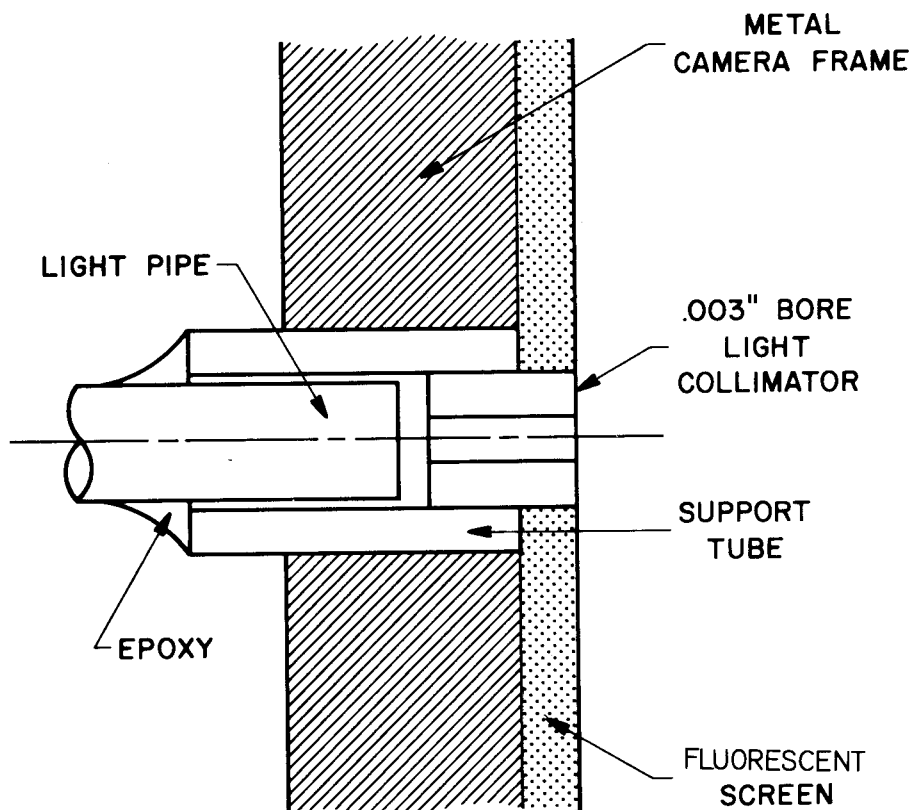

FIG. 5 Section of Laue Camera Platen Showing Light Pipe and Collimating Tube

shall be agreed upon between the parties to the test.

### TEST METHOD A—X-RAY EDGE DIFFRACTION METHOD

#### 8. Summary of Test Method

8.1 In this test method a holding fixture which uniquely orients the wafer being tested with respect to its geometric features is used to position the wafers with respect to the X-ray goniometer. The goniometer is rotated to determine the Bragg angle with respect to the geometric features by X-ray diffraction from the crystallographic planes of the wafer edge, first with the wafer front surface up and then with front surface down. The average angular deviation is calculated from the goniometer readings.

#### 9. Apparatus

9.1 *X-ray and Goniometer Apparatus*, in accordance with 5.1 of Test Methods F 26, except that the X-ray beam shall be collimated using a vertical slit.

9.2 *Wafer-Holding Fixture*, to orient the sample wafer uniquely with respect to the X-ray goniometer (see Fig. 1). The fixture must include a vacuum hold-down with a flat horizontal surface and a reference fence perpendicular to this surface. These components establish an *x-y* axis that is fixed with respect to the goniometer and the X-ray beam. The exact dimensions of the fixture depend on the layout of the X-ray apparatus. The critical features are:

9.2.1 The horizontal surface must be parallel to the plane of the X-ray beam so that the diffracted beam impinges on the detector (see Fig. 2).

9.2.2 Both the side of the reference fence against which the wafer flat is located, and the fixture surface to which the reference fence mates, must be flat to within one part per 10 000.

#### 10. Procedure

10.1 Position the detector so that the angle between the extension of the incident X-ray beam and the line joining the detector and the axis of rotation of the specimen is equal (to the nearest minute) to twice the Bragg angle (Fig. 2).

NOTE 2—This angle (twice the Bragg angle) is listed in Table 1 for CuK $\alpha$  radiation for the recommended reflecting planes corresponding to common silicon slice flat locations.

10.2 Place the wafer to be tested on the fixture, front surface up. Take care to ensure that the flat is securely located against the reference fence and activate the vacuum holddown.

10.3 With the goniometer movement mechanism, adjust the fixture about the axis of rotation perpendicular to the incident and reflected beams until the diffracted intensity is at a maximum.

10.4 Record to the nearest 1 min, as  $\psi_1$ , the angle that is indicated on the goniometer.

10.5 Remove the wafer from the fixture, turn it over so that the front surface is now down and repeat 10.2 through 10.4. For the second reading in 10.4, record the value as  $\psi_3$ .

#### 11. Calculation

11.1 Calculate and record the average angular deviation as follows:

$$\alpha = (\psi_1 - \psi_3) / 2$$

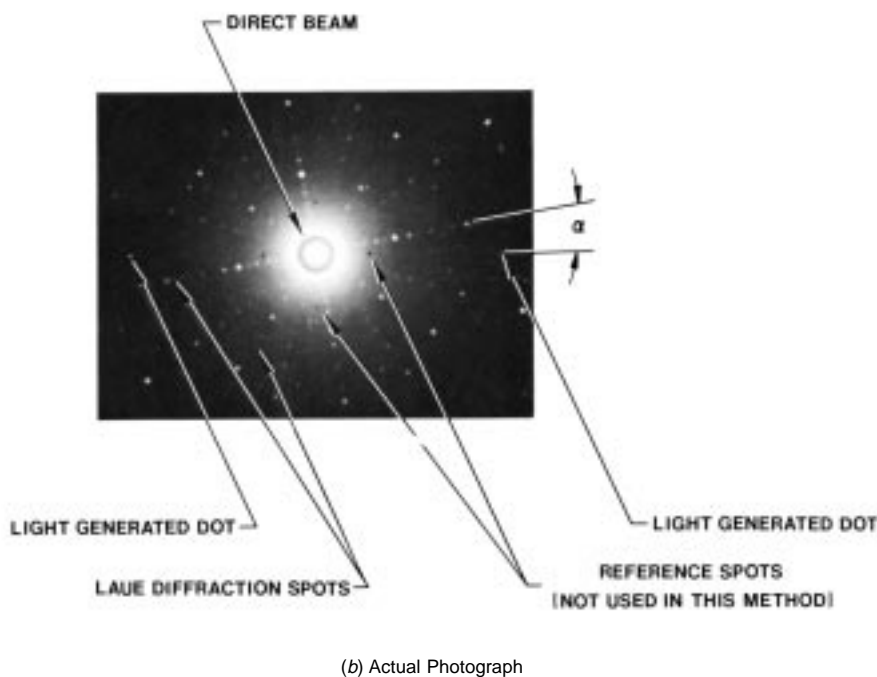
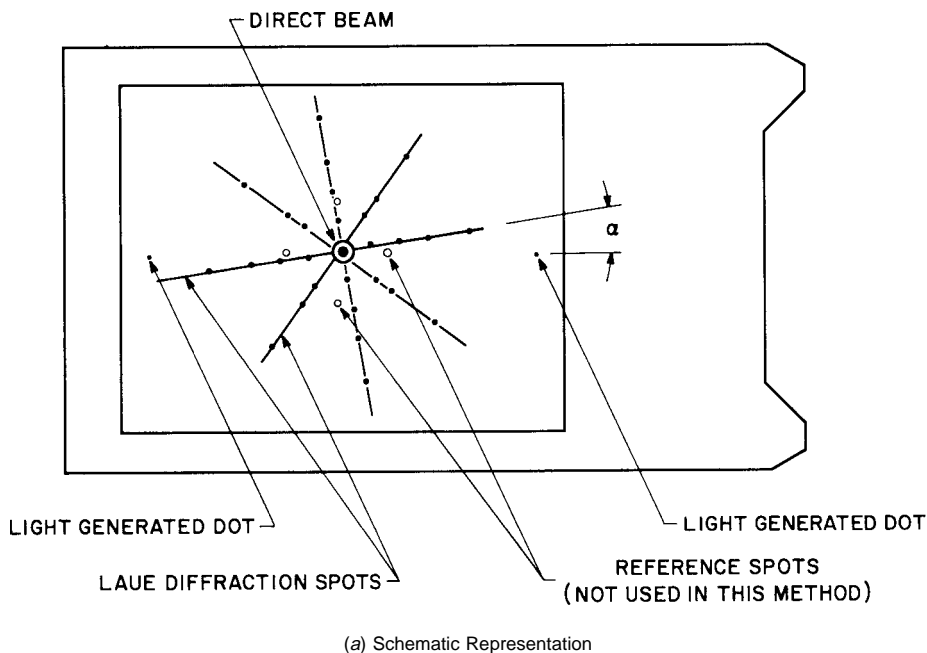

**FIG. 6 Laue Pattern**

**TABLE 1 Bragg Angles,  $\theta$ , for X-Ray Diffraction of Cu-K $\alpha$  Radiation in Silicon Crystal<sup>A</sup>**

Fiducial or Flat location			Recommended Reflecting Plane			Detector location (2 × Bragg Angle)
h,	k,	l,	h,	k,	l,	
1	1	0	2	2	0	47° 20'
2	1	1	4	2	2	88° 08'
1	0	0	4	0	0	69° 12'

<sup>A</sup>Wavelength,  $\gamma = 1.5417 \text{ \AA}$ .

where:  
 $\alpha$  = average angular deviation,

$\psi_1$  = first angle reading taken on goniometer, and  
 $\psi_3$  = second angle reading taken on goniometer.

**12. Report**

- 12.1 Report the following information:
  - 12.1.1 Identity of samples tested including vendor and vendor lot identity,
  - 12.1.2 Date of test and identity of operator making the measurements,
  - 12.1.3 Specified flat and surface orientations, and
  - 12.1.4 Measured values of  $\psi_1$  and  $\psi_3$  and the calculated value of  $\alpha$  for each wafer.

### 13. Precision and Bias

13.1 The single-instrument, single-operator repeatability of this measurement was estimated by measuring one slice 50 times (25 times each side). This test yielded a distribution of calculated values of  $\alpha$  with a 1- $\sigma$  value of 1.94 min.

### TEST METHOD B—LAUE BACK REFLECTION X-RAY METHOD

### 14. Summary of Test Method

14.1 In this test method the wafer is mounted in a Laue back-reflection X-ray camera. In this apparatus a collimated beam of “white” (continuous or Bremsstrahlung) radiation is directed at the wafer flat. A spot is produced on the film for each set of crystal planes that satisfies the Bragg equation for any wavelength component of the impinging radiation. The pattern on the film is read with an engineering drafting head. When the flat surface is within 5° of the specified low-index plane, the angle between the nearest zone of Laue spots that goes through the center of the pattern and the zero reference line is a direct measure of the angular deviation.

### 15. Apparatus

15.1 *X-Ray Diffraction Apparatus* (commercially available—), utilizing a silver or tungsten tube as the X-ray source and including a shutter to control the X-ray exposure.

15.2 *Laue Back-Reflection X-ray Camera*, with the following features (see Fig. 3):

15.2.1 *Mounting Track*, with the upper surface and one side round precision flat perpendicular to each other, aligned with the X-ray beam from the source.

15.2.2 *Wafer Holding Fixture*, (see Fig. 4) on which two plane surfaces are ground so that when it is clamped to the mounting track one surface is perpendicular and the other is parallel with the horizontal (upper) surface of the mounting track to 1 min of arc (29  $\mu\text{m}$  in 100 mm). The vertical surface contains holes connected to a vacuum line through a fitting on the back of the fixture. In use, the flat is aligned to the horizontal reference surface and the wafer is held against the vertical surface by the vacuum.

15.2.3 *Camera*, having a film holder with provision for establishing precisely a horizontal reference line. This is conveniently done by installing a light source with two light pipes and 0.003-in. (80- $\mu\text{m}$ ) diameter light collimators at the midpoint of the shorter dimension of the film, as near to the edges of the sensitive area of the film as possible (see Fig. 5). A tube for collimating the X-ray beam is required at the center of the film holder (see Fig. 3).

NOTE 3—Use of high-speed “instant” film together with a fluorescent screen results in shorter test times than with wet-processed films.<sup>11</sup> A holder of this type is commercially available. This holder has built into it four reference spots which define two orthogonal lines which pass through the center of the film when the X-ray beam collimator is located (these reference spots are not utilized in the present test method). If this type of holder is used, the collimator tube must not protrude above the surface of

the fluorescent screen because of film and clip interference problems during loading and processing of the film.

15.2.4 *Camera Mounting Fixture*, for clamping the camera to the mounting track so that the collimator is aligned with the X-ray beam and the horizontal reference line established by the light-generated dots is parallel with the upper surface of the mounting track to 1 min of arc (29  $\mu\text{m}$  in 100 mm).

15.3 *Drafting Head Protractor*, with a clear plastic blade and finest vernier divisions of six min or less for reading the Laue photograph. A straight line, approximately 5 in. (130 mm) long, and in line with the centerpoint of the protractor, is inscribed on the bottom of the plastic blade.

### 16. Procedure

16.1 Place the wafer to be tested on the wafer holding fixture so that the flat is resting securely against the reference flat on the fixture. Turn on the vacuum to hold the wafer securely against the fixture.

16.2 Turn on the X-ray source, adjust the voltage and current (Note 4), and load the film into the camera. Open the X-ray shutter and expose the film for an appropriate time (Note 5). During exposure, pulse the light to generate the dots which define the horizontal reference line, and develop the film.

NOTE 4—For a tungsten X-ray tube typical voltage and current are 50 to 60 kV and 20 to 30 mA, respectively.

NOTE 5—Use of high-speed, instant film (ASA 300) and a fluorescent screen results in typical exposure times of 1 to 2 min.

16.3 Read the Laue pattern on the film.

16.3.1 Align the scribed line on the underside of the drafting head protractor with the two light-generated dots that define the horizontal reference line and set the protractor to 0°.

16.3.2 Rotate the protractor so that the scribed line is aligned with the zone of Laue spots that (1) passes through the center of the pattern and (2) is nearest to the horizontal reference line (see Fig. 6).

16.3.3 Read to the nearest 0.1° (6 min) the angle on the protractor and record the value as the angular deviation,  $\alpha$ .

### 17. Report

17.1 Report the following information:

17.1.1 Identity of sample tested including vendor and vendor lot identity,

17.1.2 Date of test and identity of operator making the measurements,

17.1.3 Specified flat and surface orientation,

17.1.4 The measured angular deviation  $\alpha$  for each wafer, and

17.1.5 The photograph or a copy of the photograph of the Laue pattern for each wafer.

### 18. Precision and Bias

18.1 The single-instrument, multi-operator precision of this test method was estimated by extensive testing with three operators. This test yielded a distribution of readings with a 1- $\sigma$  value of 7 min.

### 19. Keywords

19.1 crystallographic orientation; flats; Laue defraction; silicon; single crystal

<sup>11</sup> Schmidt, P. H., and Spencer, E. G., “X-Ray Diffraction Camera Using Polaroid Film,” *Review of Scientific Instruments*, Vol 35, No. 8, pp. 957–958, 1964.

**NOTICE: This standard has either been superseded and replaced by a new version or discontinued.  
Contact ASTM International ([www.astm.org](http://www.astm.org)) for the latest information.**



*ASTM International takes no position respecting the validity of any patent rights asserted in connection with any item mentioned in this standard. Users of this standard are expressly advised that determination of the validity of any such patent rights, and the risk of infringement of such rights, are entirely their own responsibility.*

*This standard is subject to revision at any time by the responsible technical committee and must be reviewed every five years and if not revised, either reapproved or withdrawn. Your comments are invited either for revision of this standard or for additional standards and should be addressed to ASTM International Headquarters. Your comments will receive careful consideration at a meeting of the responsible technical committee, which you may attend. If you feel that your comments have not received a fair hearing you should make your views known to the ASTM Committee on Standards, at the address shown below.*

*This standard is copyrighted by ASTM International, 100 Barr Harbor Drive, PO Box C700, West Conshohocken, PA 19428-2959, United States. Individual reprints (single or multiple copies) of this standard may be obtained by contacting ASTM at the above address or at 610-832-9585 (phone), 610-832-9555 (fax), or [service@astm.org](mailto:service@astm.org) (e-mail); or through the ASTM website ([www.astm.org](http://www.astm.org)).*