



Designation: F 980M – 96

METRIC

## Standard Guide for Measurement of Rapid Annealing of Neutron-Induced Displacement Damage in Silicon Semiconductor Devices [Metric] <sup>1</sup>

This standard is issued under the fixed designation F 980M; the number immediately following the designation indicates the year of original adoption or, in the case of revision, the year of last revision. A number in parentheses indicates the year of last reapproval. A superscript epsilon ( $\epsilon$ ) indicates an editorial change since the last revision or reapproval.

### 1. Scope

1.1 This guide defines the requirements and procedures for testing silicon discrete semiconductor devices and integrated circuits for rapid-annealing effects from displacement damage resulting from neutron radiation. This test will produce degradation of the electrical properties of the irradiated devices and should be considered a destructive test. Rapid annealing of displacement damage is usually associated with bipolar technologies.

1.2 *This standard does not purport to address all of the safety concerns, if any, associated with its use. It is the responsibility of the user of this standard to consult and establish appropriate safety and health practices and determine the applicability of regulatory limitations prior to use.*

### 2. Referenced Documents

#### 2.1 ASTM Standards:

- E 666 Practice for Calculating Absorbed Dose from Gamma or X Radiation <sup>2</sup>
- E 720 Guide for Selection of a Set of Neutron-Activation Foils for Determining Neutron Spectra Used in Radiation-Hardness Testing of Electronics <sup>2</sup>
- E 721 Guide for Determining Neutron Energy Spectra with Neutron-Activation Foils for Radiation-Hardness Testing of Electronics <sup>2</sup>
- E 722 Practice for Characterizing Neutron Energy Fluence Spectra in Terms of An Equivalent Monoenergetic Neutron Fluence for Radiation-Hardness Testing of Electronics <sup>2</sup>
- F 1032 Guide for Measuring Time-Dependent Total-Dose Effects in Semiconductor Devices Exposed to Pulsed Ionizing Radiation <sup>3</sup>

### 3. Terminology

#### 3.1 Definitions of Terms Specific to This Standard:

3.1.1 *annealing factor*—the ratio of the displacement damage (as manifested in device parametric measurements) as a function of time following a pulse of neutrons and the displacement damage remaining at the time the initial damage achieves quasi equilibrium, approximately 1000 s.

3.1.1.1 *Discussion*—Annealing factors have typical values of 2 to 10 for these periods of time following irradiation; see Refs (1, 2, 3, 4, 5, 6, 7). <sup>4</sup>

3.1.2 *in situ tests*—electrical measurements made on devices before, after, or during irradiation while they remain in the immediate vicinity of the irradiation location. All rapid-annealing measurements are performed in situ because measurement must begin immediately following irradiation (usually <1 ms).

3.1.3 *remote tests*—electrical measurements made on devices that are physically removed from the irradiation location. For the purpose of this guide, remote tests are used only for the characterization of the parts before and after they are subjected to the neutron radiation (see 6.4).

### 4. Summary of Guide

4.1 A rapid-annealing radiation test requires continual time-sequential electrical-parameter measurements of key parameters of a device be made immediately following exposure to a pulse of neutron radiation capable of causing significant displacement damage.

4.2 Because many factors enter into the effects of the radiation on the part, parties to the test must establish many circumstances of the test before the validity of the test can be established or the results of one group of parts can be meaningfully compared with those of another group. Those factors that must be established are as follows:

<sup>1</sup> This guide is under the jurisdiction of ASTM Committee F-1 on Electronics and is the direct responsibility of Subcommittee F01.11 on Quality and Hardness Assurance.

Current edition approved June 10, 1996. Published August 1996. Originally published as F 980 – 86. Last previous edition F 980 – 92.

<sup>2</sup> *Annual Book of ASTM Standards*, Vol 12.02.

<sup>3</sup> Discontinued; see *1993 Annual Book of ASTM Standards*, Vol 10.04.

<sup>4</sup> The boldface numbers in parentheses refer to the list of references at the end of this standard.

4.2.1 *Radiation Source*—The type and characteristics of the neutron radiation source to be used (see 6.2).

4.2.2 *Dose Rate Range*—The range of ionizing dose rates within which the neutron exposures must take place. These dose rates and the subsequent device response should not influence the parametric measurements being made (see 6.6).

4.2.3 *Operating Conditions*—The test circuit, electrical biases to be applied, and operating sequence (if applicable) for the part during and following exposure (see 6.5).

4.2.4 *Electrical Parameter Measurements*—The pre-irradiation and postirradiation measurements to be made on the test unit and the measurements of changes in the annealing-sensitive parameters to be made beginning immediately after exposure.

4.2.5 *Time Sequence*—The exposure time, time after exposure when measurements of the selected parameter(s) are to begin, time when measurements are to end, and time intervals between measurements.

4.2.6 *Neutron Fluence Levels*—The fluence range required to sustain the desired damage to the device.

4.2.6.1 *Total Dose Levels*—If the part is sensitive to an accompanying type of radiation (such as gamma rays) the levels to which the part can be exposed before the rapid-annealing measurement is affected (see 6.4).

4.2.7 *Dosimetry*—The type and technique used to measure the radiation levels. This is dependent to some extent on the radiation source selection.

4.2.7.1 Since a pulsed radiation source is implied for a rapid-annealing measurement, a time profile of the radiation intensity and its time relationship to the subsequent measurements is extremely helpful (see 7.1).

4.2.8 *Temperature*—The temperature during exposure and the allowable temperature change during the time interval of the rapid-annealing measurement (see 6.7).

4.2.9 *Experimental Configuration*—The physical arrangement of the radiation source, test unit, radiation shielding, and any other mechanical or electrical elements of this test.

## 5. Significance and Use

5.1 Electronic circuits used in many space, military, and nuclear power systems may be exposed to various levels and time profiles of neutron radiation. It is essential for the design and fabrication of such circuits that test methods be available that can determine the vulnerability or hardness (measure of nonvulnerability) of components to be used in them. A determination of hardness is often necessary for the short term ( $\approx 100 \mu\text{s}$ ) as well as long term (permanent damage) following exposure.

## 6. Interferences

6.1 There are many factors that can affect the results of rapid-annealing tests. Care must be taken to control these factors to obtain consistent and reproducible results.

6.2 *Pulsed Neutron-Radiation Source*—Because the objective of a rapid-annealing test is to observe short-term damage effects, it is implied that this damage is incurred in a short time period and is severe enough to be easily measured. These factors imply a pulsed neutron source. The most commonly used source for rapid-annealing tests is a pulsed reactor. There

are two types commonly used; the bare-assembly fast-burst reactor and the water-moderated TRIGA type (see Ref (8)).

6.3 *Energy Spectrum*—The neutron energies should be known to ensure correlation with design requirements. It should also be known that adequate damage to the part can be inflicted. Neutron fluences ( $\text{n/cm}^2$ ) are commonly specified in terms of 1 MeV silicon damage equivalence or in percentage of the total above a given energy (see 7.5.1 and Guides E 720 and E 721, and Practice E 722).

6.4 *Effects of Other Radiation*—Some parts that will be evaluated for neutron-induced rapid-annealing effects may also be affected by other types of radiation that may accompany the particles (such as gamma radiation with neutrons). (See Guide F 1032 and Practice E 666.) For this reason, characterization of the part type to both types of radiation is necessary prior to the rapid-annealing tests.

6.5 *Bias*—Rapid annealing effects from displacement-damage are usually associated with bipolar devices. Most of these effects are related to the electron density in semiconductor device junctions, which is a function of the operating-current bias level. Operating conditions during exposure and the rapid-annealing periods must be chosen to give a large or small degree of annealing as desired. Lacking any preference on the most desirable bias, those conditions that approximate the actual device application may be used.

### 6.6 Dose Rate:

6.6.1 The excess charge carrier concentration depends on the dose rate. High densities of excess carriers can affect trapping site charge states as well as carrier mobilities and lifetimes, altering post-radiation trapped charge densities and distributions. If the neutron radiation is accompanied by an ionizing radiation, the rapid-annealing measurements may be affected. The charge carriers created by ionizing radiation act just like those carriers injected by biasing the device (see 6.5).

6.6.2 Because the device parameter measured during a rapid-annealing test may be significantly altered by a high dose rate, it is necessary to ensure (through some functionality check) that the dose rate during irradiation does not reach a level that will upset the parameter being measured.

6.6.3 Photocurrents produced by the excess carriers generated by an ionizing radiation can alter internal bias levels of a semiconductor device, thereby causing a variation in the rapid-annealing response. Care must be taken to ensure that dose-rate levels remain below a level that will cause debiasing of the device.

6.6.4 For all of these reasons, the dose-rate range allowed for the rapid-annealing measurements must be considered by the parties to the test.

### 6.7 Temperature:

6.7.1 Because annealing of neutron-induced displacement damage is also dependent upon thermally activated processes as well as current injection, the temperature during irradiation and testing can affect the rapid-annealing measurements. It is recommended that all radiation exposures and measurements be done at  $23 \pm 5^\circ\text{C}$  unless unique requirements or unusual environmental conditions dictate otherwise.

6.7.2 Because rapid annealing is affected by temperature, it is important to monitor possible temperature rise resulting from the pulse of radiation or a temperature rise of the radiation source.

6.7.3 Device heating may also occur from high device current. Injection level of device operation is important and should be known at all times; see Refs (1-9.)

6.8 *Handling*—As in any other type of testing, care must be taken in handling the parts. This especially applies to parts that are susceptible to damage from electrostatic discharge.

6.9 *Radiation Damage*—If a test fixture is used over a long period of time in a radiation environment, components and materials of the fixture can become damaged, resulting in incorrect parameter readings during the test. Such fixtures should be checked regularly for socket or printed-circuit-board leakage and degradation of any peripheral components used in the test.

6.10 *Induced Radioactivity*—Because low-energy (thermal) neutrons often accompany the high-energy neutrons required to cause displacement damage, it is necessary to realize that both types of neutrons cause the parts to become radioactive. Prescribed radiation-safety practices must be exercised in handling these parts.

#### 6.11 *Parameter Selection:*

6.11.1 Selection of the electrical parameter to be monitored as the indicator of the rapid-annealing characteristics can be critical to the test and may be very difficult. The most desirable condition is one that enables the experimenter to monitor a parameter whose degradation is monotonically proportional to the neutron fluence and is also a good indicator of the functional behavior of the device. If these criteria cannot be met, then a parameter should be selected that is easily measured and is prominent in the planned use of the part.

6.11.2 The parameter selected for the rapid-annealing measurement must be fully characterized for the part type as a function of fluence prior to the test. This knowledge enables the proper selection of the fluence level to be used in the test.

6.11.3 Interpretation of the results can be very difficult unless the relationship of the electrical parameters to the fluence is well known. This difficulty applies to any part with a nonlinear parameteric relationship to fluence.

6.12 Because the pulse of neutrons will vary in duration from source-to-source, it should be noted that annealing is occurring concurrently with the introduction of the damage.

## 7. Apparatus

7.1 *Pulsed Neutron Source*, with adequate neutron energy and fluence to cause significant displacement damage must be used. It is extremely helpful if the source is readily accessible and dosimetry techniques for determining the fluence and radiation time profile are already established. If not, dosimetry measurements in accordance with referenced guidelines will be necessary (Guides E 720 and E 721).

7.1.1 *Fast-Burst Reactor*—These neutron sources possess many features that are desirable for rapid-annealing measurements. They can produce a high neutron fluence in a short burst (approximately 100  $\mu$ s) with an accompanying gamma-radiation dose of approximately  $1 \times 10^3$  Gy(Si) and a dose rate of,  $\approx 1 \times 10^7$  Gy(Si)/s. Selective shielding can be used to

alter the neutron-to-gamma ratio if it is necessary. The neutron-to-gamma ratio of fast-burst reactors is approximately  $4.5 \times 10^{11}$  (n/cm<sup>2</sup> to Gy(Si)).

7.1.2 *Water-Moderated Pulsed Reactor*— These neutron sources have a pulse width of about 7 ms and, therefore, will not allow measurement of rapid annealing as quickly as a fast-burst reactor. In addition, this type of reactor has a relatively high number of low-energy neutrons and will thereby cause the device under test to become more radioactive. The neutron-to-gamma ratio of the water-moderated pulsed reactor is approximately  $4 \times 10^{10}$  (n/cm<sup>2</sup> to Gy(Si)).

7.2 *Bias Circuit*—The bias circuit may be simple or complex, depending on the part type and parameter to be monitored. It may be made to accept a single device or several devices, depending on requirements. Design and fabrication practices that prevent oscillations, minimize leakage currents, prevent device damage, and promote accurate measurements should be used. For in situ measurements, provisions must be made to minimize cable noise and other forms of noise that may be induced into the circuit by the radiation source or any of its ancillary equipment.

7.3 *Test Instrumentation*—Standard device parameter measurement instruments are required. Depending on the device type and parameter to be measured, these can range from simple breadboard circuits to complex, computer-controlled IC test systems. All equipment is to be in calibration for the entire period of the test.

7.4 *Typical Test Setup*—A typical test setup for characterizing the rapid-annealing response of a bipolar device using a fast-burst reactor as the source of neutrons is shown in Fig. 1.

#### 7.5 *Dosimetry System:*

7.5.1 The neutron fluence for each exposure is measured with activation foils. Often a single foil such as sulfur can be used, once the spectrum has been determined, in accordance with referenced guidelines.

7.5.2 Gamma dosimetry for the fast-burst reactor is performed using Thermoluminescent Dosimeters (TLDs) to determine dose and PIN photo diodes to establish the dose rate. Preselected fluence levels and dose rates are then obtained by irradiating at a selected reactor output. (Proper use of TLD systems is described in Practices E 666.)

7.5.3 Other dosimetry can be used for the determination of both neutron radiation or gamma radiation levels. The calibration of dosimetry systems should be traceable to NIST standards.

## 8. Procedure

8.1 Parties to the test must first establish the circumstances of the test. As a minimum, they should establish the items specified in 4.2 and consider all of the possible interferences described in Section 6 when making these decisions.

8.2 Prepare bias fixtures, test circuits, and test programs.

8.3 Do preliminary source dosimetry, as needed, and establish the dosimetry system calibration.

8.4 Make pre-irradiation parameter or functional measurements, or both.

8.5 Bias the parts as agreed upon between the parties to the test. Irradiate to the agreed radiation level.

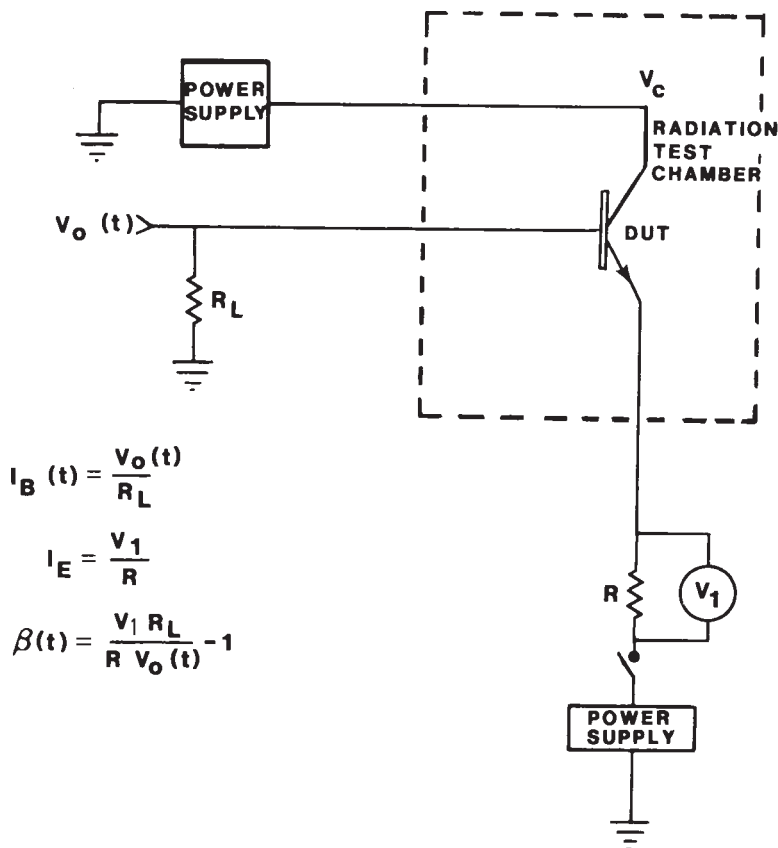

NOTE 1—For a constant current,  $R$  must be large (or use a constant-current source).

NOTE 2—Switch must be a mercury-wetted type or a comparable nonbounce switch.

NOTE 3— $V_1 \gg V_o(t)$ .

NOTE 4—For an IC, the test circuit and parameter to be measured may be significantly different from those shown.

**FIG. 1 Schematic of a Simple Bipolar Rapid-Annealing Test Circuit**

8.6 Make measurements at the agreed times following the radiation exposure.

8.7 If the preselected damage level of the device allows additional exposures, repeat 8.5 and 8.6, if desired.

## 9. Report

9.1 As a minimum, report the following information:

9.1.1 Information identifying the devices tested. All information available for device identification should be included; for example, device type, serial number, manufacturer, date lot code, diffusion lot designation, wafer lot designation, and so forth.

9.1.2 A listing of items agreed upon between the parties to the test including all the conditions described in 4.2.

9.1.3 A schematic of the bias circuit.

9.1.4 A diagram of the physical test configuration.

9.1.5 A tabulation of test parameter measurement data.

## 10. Keywords

10.1 annealing factor; displacement damage; integrated circuits; neutron damage; neutron degradation; rapid annealing; semiconductor devices



## F 980M – 96

### REFERENCES

- (1) Sander, H. H., and Gregory, B. L., "Transient Annealing in Semiconductor Devices Following Pulsed Neutron Irradiation," *IEEE Transactions on Nuclear Science*, NS-13, No. 6, December 1966.
- (2) Harrity, J. W., and Mallon, C. E., *Short-Term Annealing in Semiconductor Materials and Devices*, AFWL-TR-67-45, AD822283, October 1967.
- (3) Gregory, B. L., and Sander, H. H., "Injection Dependence of Transient Annealing in Neutron-Irradiated Silicon Devices," *IEEE Transactions on Nuclear Science*, NS-14, No. 6, December 1967.
- (4) Harrity, J. W., Azarewicz, J. L., Leadon, R. E., Colwell, J. F., and Mallon, C. E., *Experimental and Theoretical Investigation of Functional Dependence of Rapid Annealing*, AFWL-TR-71-28, AD889998, October 1971.
- (5) Srour, J. R., and Curtis, O. L., Jr., *Journal of Applied Physics*, No. 4082, 1969, p. 40.
- (6) Leadon, R. E., "Model for Short-Term Annealing of Neutron Damage in P-Type Silicon," *IEEE Transactions on Nuclear Science*, NS-17, No. 6, December 1970.
- (7) McMurray, L. R., and Messenger, G. C., "Rapid Annealing Factor for Bipolar Silicon Devices Irradiated By Fast Neutron Pulse," *IEEE Transactions on Nuclear Science*, NS-28, No. 6, December 1981.
- (8) Kelly, J. G., Luera, T. F., Posey, L. D., and Williams, J. G., "Simulation Fidelity Issues in Reaction Irradiation of Electronics Reactor Environments," *IEEE Transactions on Nuclear Science*, NS-35, No. 6, December 1988.
- (9) Wrobel, T. F., and Evans, D. C., "Rapid Annealing in Advanced Bipolar Microcircuits," *IEEE Transactions, on Nuclear Science*, NS-29, No. 6, December 1982.

*ASTM International takes no position respecting the validity of any patent rights asserted in connection with any item mentioned in this standard. Users of this standard are expressly advised that determination of the validity of any such patent rights, and the risk of infringement of such rights, are entirely their own responsibility.*

*This standard is subject to revision at any time by the responsible technical committee and must be reviewed every five years and if not revised, either reapproved or withdrawn. Your comments are invited either for revision of this standard or for additional standards and should be addressed to ASTM International Headquarters. Your comments will receive careful consideration at a meeting of the responsible technical committee, which you may attend. If you feel that your comments have not received a fair hearing you should make your views known to the ASTM Committee on Standards, at the address shown below.*

*This standard is copyrighted by ASTM International, 100 Barr Harbor Drive, PO Box C700, West Conshohocken, PA 19428-2959, United States. Individual reprints (single or multiple copies) of this standard may be obtained by contacting ASTM at the above address or at 610-832-9585 (phone), 610-832-9555 (fax), or service@astm.org (e-mail); or through the ASTM website (www.astm.org).*