



# Standard Test Method for Residual Chlorine in Water<sup>1</sup>

This standard is issued under the fixed designation D 1253; the number immediately following the designation indicates the year of original adoption or, in the case of revision, the year of last revision. A number in parentheses indicates the year of last approval. A superscript epsilon ( $\epsilon$ ) indicates an editorial change since the last revision or reapproval.

*This standard has been approved for use by agencies of the Department of Defense.*

## 1. Scope\*

1.1 This test method covers the determination of residual chlorine in water by direct amperometric titration.

1.2 Within the constraints specified in Section 6, this test method is not subject to commonly encountered interferences and is applicable to most waters. Some waters, however, can exert an iodine demand, usually because of organic material, making less iodine available for measurement by this test method. Thus, it is possible to obtain falsely low chlorine readings, even though the test method is working properly, without the user's knowledge.

1.3 Precision data for this test method were obtained on estuary, inland main stem river, fresh lake, open ocean, and fresh cooling tower blowdown water. Bias data could not be determined because of the instability of solutions of chlorine in water. It is the user's responsibility to ensure the validity of the test method for untested types of water.

1.4 In the testing by which this standard was validated, the direct and back starch-iodide titrations and the amperometric back titration, formerly part of this standard, were found to be unworkable and were discontinued in 1986. Historical information is presented in Appendix X1.

NOTE 1—Orthotolidine test methods have been omitted because of poor precision and accuracy.

1.5 *This standard does not purport to address all of the safety concerns, if any, associated with its use. It is the responsibility of the user of this standard to establish appropriate safety and health practices and determine the applicability of regulatory limitations prior to use.*

## 2. Referenced Documents

### 2.1 ASTM Standards:

D 1129 Terminology Relating to Water<sup>2</sup>

D 1193 Specification for Reagent Water<sup>2</sup>

D 2777 Practice for Determination of Precision and Bias of Applicable Methods of Committee D19 on Water<sup>2</sup>

<sup>1</sup> This test method is under the jurisdiction of ASTM Committee D19 on Water and is the direct responsibility of Subcommittee D19.05 on Inorganic Constituents in Water.

Current edition approved June 10, 2003. Published July 2003. Originally approved in 1953. Last previous edition approved in 1996 as D 1253 – 86 (1996).

<sup>2</sup> *Annual Book of ASTM Standards*, Vol 11.01.

D 3370 Practices for Sampling Water from Closed Conduits<sup>2</sup>

D 5847 Practice for Writing Quality Control Specifications for Standard Test Methods for Water Analysis<sup>3</sup>

## 3. Terminology

3.1 *Definitions*: For definitions of terms used in this test method, refer to Terminology D 1129.

3.2 *Definitions of Terms Specific to This Standard*:

3.2.1 *combined residual chlorine*,  $n$ —residual consisting of chlorine combined with ammonia nitrogen or nitrogenous compounds.

3.2.2 *free available chlorine residual*,  $n$ —residual consisting of hypochlorite ions, hypochlorous acid, or a combination thereof.

3.2.3 *total residual chlorine (chlorine residual)*,  $n$ —the amount of available chlorine-induced oxidants present in water at any specified period, subsequent to the addition of chlorine.

NOTE 2—Chlorine present as chloride is neither included in these terms nor determined by this test method.

NOTE 3—Bromine, bromine combined with ammonia or nitrogenous compounds, and chlorine dioxide are not distinguished by this test method from the corresponding chlorine compounds.

## 4. Summary of Test Method

4.1 This is an amperometric titration test method utilizing phenylarsine oxide as the titrant. When the titrator cell is immersed in a sample containing chlorine, current is generated. As phenylarsine oxide is added, the chlorine is reduced and the generation of current ceases. When chlorine is present as a chloramine, potassium iodide is added, releasing iodine, which is titrated in a similar manner. The iodine content is calculated in terms of free chlorine.

## 5. Significance and Use

5.1 Chlorine is used to destroy or deactivate a variety of unwanted chemicals and microorganisms in water and wastewater.

5.2 An uncontrolled excess of chlorine in water, whether free available or combined, can adversely affect the subsequent use of the water.

<sup>3</sup> *Annual Book of ASTM Standards*, Vol 11.02.

\*A Summary of Changes section appears at the end of this standard.

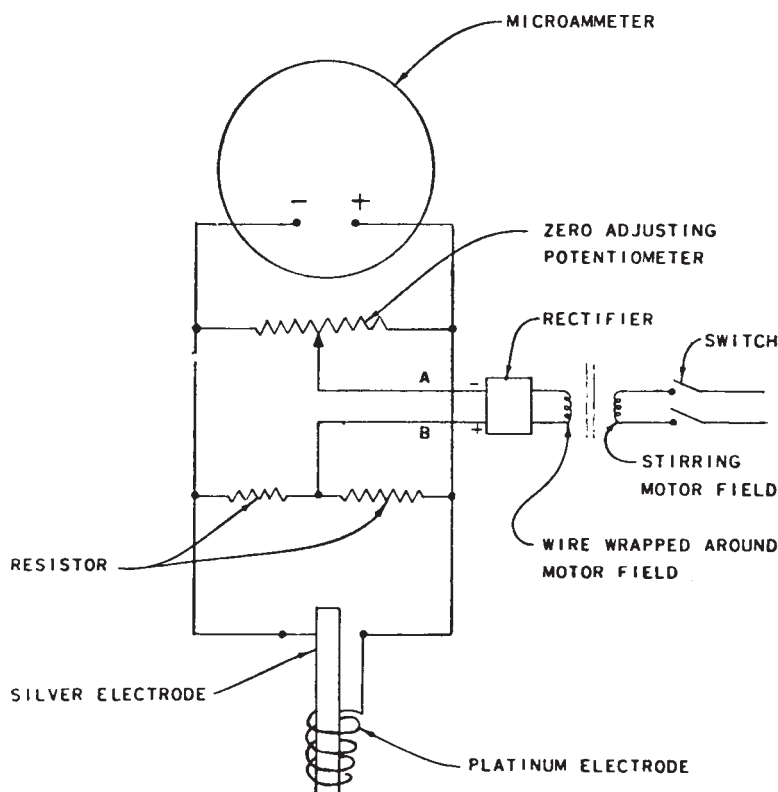

FIG. 1 Wiring Diagram of Amperometric Titrator

## 6. Interferences

6.1 This test method is not subject to interferences from temperature, color, or turbidity of sample.

6.2 Values of pH above 8.0 interfere by slowing the reaction rate. Buffering the sample to pH 7.0 or less eliminates the interference.

6.3 Erratic behavior of the apparatus in the presence of cupric ions has been reported.

6.4 Cuprous and silver ions tend to poison the electrode of the titrator.

6.5 Nitrogen trichloride and some N-chloro compounds are often present as products of the chlorination of wastewaters and will titrate partially as free available chlorine and partially as combined residual chlorine. This error can be avoided only in the determination of total residual chlorine.

6.6 Exposure to high concentrations of free available chlorine causes a film-type polarization that reverses very slowly. This can be avoided by diluting the sample with water to less than 10 mg/L of free available chlorine.

6.7 If chlorine dioxide is present, an unknown portion titrates as free available chlorine. Total chlorine dioxide titrates as total residual chlorine.

6.8 Depending upon final pH, chlorination of waters containing ammonia or nitrogenous organic compounds can produce high concentrations of dichloramine. This compound produces four to five times as much current as monochloramine. The current produced by as little as 5 mg/L of dichloramine can cause the microammeter pointer to read offscale even at the end point in the titration of free available chlorine. This may be overcome by use of an opposing voltage in the

apparatus' circuitry. The instrument's manufacturer should be consulted in this regard.

## 7. Apparatus

7.1 *Amperometric Titration Apparatus*<sup>4,5</sup>—Refer to Fig. 1.

NOTE 4—When the titrator has been out of service for a day or more, check the electrode for sensitivity by noting the rapidity of the pointer deflection. If the pointer responds slowly after the addition of KI solution, add a small amount of biiodate. If it responds slowly to free available chlorine, sensitize it by adding chlorine.

7.2 *Glassware*—Condition with water containing at least 10 mg/L of residual chlorine for at least 2 h prior to use and then rinse thoroughly.

## 8. Reagents and Materials

8.1 *Purity of Reagents*—Reagent grade chemicals shall be used in all tests. Unless otherwise indicated, it is intended that all reagents shall conform to the specifications of the Committee on Analytical Reagents of the American Chemical Society.<sup>6</sup> Other grades may be used, provided it is first ascertained that

<sup>4</sup> *Water and Sewage Works*, May 1949, p. 171, and *Journal American Water Works Association*, Vol 34, 1942, pp. 1227-1240.

<sup>5</sup> Amperometric titrators are available commercially from most laboratory supply houses.

<sup>6</sup> *Reagent Chemicals, American Chemical Society Specifications*, American Chemical Society, Washington, DC. For suggestions on the testing of reagents not listed by the American Chemical Society, see *Anal. Standards for Laboratory Chemicals*, BDH Ltd., Poole, Dorset, U.K., and the *United States Pharmacopeia and National Formulary*, U.S. Pharmacopeial Convention, Inc. (USPC), Rockville, MD.

the reagent is of sufficiently high purity to permit its use without lessening the accuracy of the determination.

**8.2 Purity of Water**—Unless otherwise indicated, references to water shall be understood to mean reagent water conforming to Specification D 1193, Type III, further treated to be free of chlorine demand. A suggested method for preparation of chlorine demand-free water is to add approximately 20 mg/L of available chlorine to Type III water, let it stand for about a week in darkness, and then expose it to sunlight until no chlorine remains.

**8.3 pH 4.0 Buffer Solution**—Dissolve 243 g of sodium acetate trihydrate and 480 g of glacial acetic acid in water and dilute to 1 L.

**8.4 pH 7.0 Buffer Solution**—Dissolve 25.4 g of monobasic potassium phosphate and 86 g of dibasic sodium phosphate in water and dilute to 1 L.

**8.5 Biiodate, Solution Standard (0.0282N)**—Dissolve 0.9163 g of potassium biiodate in water and dilute to 1 L in a volumetric flask. Store in an amber glass-stoppered bottle.

**8.6 Phenylarsine Oxide, Solution Standard (0.00564 N)**—Dissolve 0.8 g of phenylarsine oxide in 150 mL of sodium hydroxide solution (12 g/L). After settling, decant 110 mL of this solution, add 800 mL of water, and bring to a pH of 9.0 by adding hydrochloric acid (1 + 1). This should require about 2 mL of HCl (1 + 1). Continue acidification with HCl (1 + 1) until a pH of 6 to 7 is reached, as indicated by a glass-electrode system; then dilute to a total volume of 1L. Standardize to 0.00564 N against 0.0282 N biiodate solution using the titrator (7.1) as the end-point indicator. Add 1 mL of chloroform for preservation.

**8.7 Potassium Iodide Solution (50 g/L)**—Dissolve 50 g of KI in water and dilute to 1 L. Add 1 g of sodium bicarbonate to stabilize the solution. Store in an amber bottle and avoid direct exposure to sunlight.

## 9. Sampling

**9.1** Collect the sample in accordance with Practices D 3370. Take care that the sample is representative and keep it away from direct sunlight prior to analysis.

**9.2** All tests should be made as soon as possible after collection of the sample (not more than 5 min) because the residual chlorine may diminish with time, due to the chlorine demand of the sample. Where time of contact is important, the elapsed time between the addition of chlorine and the determination of chlorine should be taken into account.

## 10. Procedure

**10.1** For residual chlorine concentrations of 2.0 mg/L or less, use a 200-mL sample. For greater concentrations, use a 100-mL sample. It is preferable that the size of the sample be such that not more than 2 mL of titrant will be required to complete the titration.

**10.2 Determination of Total Residual Chlorine:**

**10.2.1** Add 1 mL of KI solution to a 200-mL sample and immediately add 1 mL of pH 4.0 buffer solution.

**10.2.2** Immerse the electrodes in the sample and start the stirrer. Adjust the microammeter pointer of the potentiometer to the right or high current side of the scale so the pointer can deflect counterclockwise during the analysis.

**10.2.3** Titrate using standard phenylarsine oxide solution, adding the titrant in small increments, and noting the deflection of the microammeter pointer. Plot the progress of the titration on linear graph paper with current on the vertical axis and titrant volume on the horizontal axis. Add a small volume of titrant, wait a few seconds, and plot the current-volume point on the graph.

**10.2.4** Readjust the potentiometer several times during the titration, if necessary, to bring the pointer back on scale.

**10.2.5** Continue the analysis by determining at least three points spread over the downward sloping titration curve and at least three points after the equivalence or end point. The latter points will indicate practically no change in current. Points just before the end point shall be disregarded in its determination. The millilitres of titrant at the end point defined by the intersection of the two linear sections of the titration curve should be recorded.

**10.3 Determination of Free Available Chlorine Residual:**

**10.3.1** Add 1 mL of pH 7.0 buffer solution to a 200-mL sample.

**10.3.2** Repeat the phenylarsine oxide titration beginning with 10.2.2.

**10.3.3** Note a rapid deflection of the pointer for each increment of titrant indicates the presence of free available chlorine. Slight counterclockwise movements of the pointer after addition of individual drops of titrant is a drift effect and does not indicate the presence of free available chlorine.

**10.4 Determination of Combined Available Chlorine Residual:**

**10.4.1** Complete the titration for the determination of free available chlorine residual as in 10.3.

**10.4.2** To the same sample, add 1 mL of KI solution and 1 mL of pH 4.0 buffer solution and repeat the titration as in 10.2.

## 11. Calculation

**11.1** Calculate the various types of chlorine residual, in milligrams per litre, as follows:

$$\text{Chlorine residual, mg/L} = 200 A/V$$

where:

- A** = phenylarsine oxide solution (0.00564 N) required for the titration of 10.2, 10.3, or 10.4, depending on the specific type of chlorine residual determined, mL, and  
**V** = sample used, mL.

## 12. Precision and Bias <sup>7</sup>

**12.1** The overall precision ( $S_t$ ) and the single operator precision ( $S_o$ ) of this test method for free available chlorine (FAC) and for total residual chlorine (TRC) were determined by eight or nine qualified cooperators each with analysis equipment and reagents at each of five sites. Each site constituted a different chlorinated cooling water matrix: estuary, inland main stem river, fresh lake, open ocean, and fresh cooling tower blowdown. Each site water was chlorinated up to

<sup>7</sup> Supporting data have been filed at ASTM International Headquarters and may be obtained by requesting Research Report RR: D19-1124.

nine levels. Samples were collected simultaneously and analyzed within 5 min of collection by all eight or nine cooperators. Duplicate sampling and analysis runs were made at each level.

12.2 The  $S_t$  and  $S_o$  for FAC was found to vary linearly with the mean concentration of FAC,  $X$ , in mg/L, over the range for  $X$  from 0.0 to 1.0.

12.2.1 For the pooled results from all of the matrices tested:

$$S_t = 0.025 + 0.199 X \quad (n = 37, r = 0.848)$$

$$S_o = 0.008 + 0.081 X \quad (n = 35, r = 0.638)$$

where:

$n$  = number of runs, and

$r$  = correlation coefficients.

12.3 The  $S_t$  and  $S_o$  for TRC was found to vary linearly with the mean concentration of TRC,  $Y$ , in mg/L, over the range for  $Y$  from 0.0 to 3.5.

12.3.1 For the pooled results from all of the matrices tested:

$$S_t = 0.022 + 0.098 Y \quad (n = 39, r = 0.865)$$

$$S_o = 0.012 + 0.024 Y \quad (n = 38, r = 0.695)$$

12.4 The bias of the test method could not be determined since the instability of solutions of chlorine in water does not permit the determination of an acceptable true value for TRC and FAC in the samples.

12.5 Precision for this test method conforms to Practice D 2777–77, which was in place at the time of collaborative testing. Under the allowances made in 1.4 of Practice D 2777–98, these precision data do meet existing requirements for interlaboratory studies of Committee D19 test methods.

### 13. Quality Control

13.1 In order to be certain that analytical values obtained using these test methods are valid and accurate within the confidence limits of the test, the following QC procedures shall be followed when analyzing residual chlorine.

#### 13.2 Calibration and Calibration Verification

13.2.1 Standardize the titrating solution against the potassium biiodate solution.

13.2.2 Verify titrating solution by analyzing a sample with a known amount of the residual chlorine. The amount of the sample shall fall within  $\pm 15\%$  of the known concentration.

13.2.3 If standardization cannot be verified, restandardize the solution.

#### 13.3 Initial Demonstration of Laboratory Capability

13.3.1 If a laboratory has not performed the test before, or if there has been a major change in the measurement system, for example, new analyst, new instrument, and so forth, a precision and bias study shall be performed to demonstrate laboratory capability.

13.3.2 Analyze seven replicates of a known solution prepared from an Independent Reference Material containing a known amount of residual chlorine. Each replicate shall be taken through the complete analytical test method including any sample preservation and pretreatment steps. The replicates may be interspersed with samples.

13.3.3 Calculate the mean and standard deviation of the seven values and compare to the acceptable ranges of bias in Section 12. This study should be repeated until the recoveries are within the limits given in Section 12. If an amount other than the recommended amount is used, refer to Practice D 5847 for information on applying the F test and t test in evaluating the acceptability of the mean and standard deviation.

#### 13.4 Laboratory Control Sample (LCS)

13.4.1 To ensure that the test method is in control, analyze an LCS containing a known amount of residual chlorine with each batch or 10 samples. If large numbers of samples are analyzed in the batch, analyze the LCS after every ten samples. The LCS shall be taken through all of the steps of the analytical method including sample preservation and pretreatment. The result obtained for the LCS shall fall within  $\pm 15\%$  of the known amount.

13.4.2 If the result is not within these limits, analysis of samples is halted until the problem is corrected and either all the samples in the batch must be reanalyzed, or the results must be qualified with an indication that they do not fall within the performance criteria of the test method.

#### 13.5 Method Blank

13.5.1 Analyze a reagent water test blank with each batch. The amount of residual chlorine found in the blank should be less than the analytical reporting limit. If the amount of residual chlorine is found above this level, analysis of samples is halted until the contamination is eliminated, and a blank shows no contamination at or above this level, or the results shall be qualified with an indication that they do not fall within the performance criteria of the test method.

#### 13.6 Matrix Spike (MS)

13.6.1 Residual chlorine is not an analyte that can be feasibly spiked into samples.

#### 13.7 Duplicate

13.7.1 To check the precision of sample analyses, analyze a sample in duplicate with each batch. The value obtained shall fall within the control limits established by the laboratory.

13.7.2 Calculate the standard deviation of the duplicate values and compare to the precision in the collaborative study using an F test. Refer to 6.4.4 of Practice 5847 for information on applying the F test.

13.7.3 If the result exceeds the precision limit, the batch shall be reanalyzed or the results shall be qualified with an indication that they do not fall within the performance criteria of the test method.

#### 13.8 Independent Reference Material (IRM)

13.8.1 In order to verify the quantitative value produced by the test method, analyze an Independent Reference Material (IRM) submitted as a regular sample (if practical) to the laboratory at least once per quarter. The amount of the IRM should be in the analytical range for the method chosen. The value obtained shall fall within the control limits established by the laboratory.

### 14. Keywords

14.1 amperometric; analysis; chlorine; water

## APPENDIX

## (Nonmandatory Information)

**X1. RATIONALE FOR DISCONTINUATION OF TEST METHODS**

X1.1 *Direct and Back Starch-Iodide Titrations and Amperometric Back Titration:*

X1.1.1 These two test methods were discontinued in 1986. These test methods may be found in *1985 Annual Book of ASTM Standards*, Vol 11.01. These test methods were originally issued in 1953.

X1.1.2 These test methods are biiodate solutions as titrating agents. Attempts to include these test methods in the round-robin testing were not successful because the reaction rate of

the biiodate solution with phenylarsine oxide was slow and inconsistent. The little data obtained were widely varied, nonreproducible, and were not relatable to the values being tested.

X1.1.3 Field experience indicates that both test methods can work if iodine solution is used in place of biiodate solution as the titrating agent. Validation of these test methods through round-robin testing, however, has not been carried out.

**SUMMARY OF CHANGES**

Committee D19 has identified the location of selected changes to this standard since the last issue (D 1253 – 86 (1996)) that may impact the use of this standard.

(1) Section 13 and 12.5 were added.

*ASTM International takes no position respecting the validity of any patent rights asserted in connection with any item mentioned in this standard. Users of this standard are expressly advised that determination of the validity of any such patent rights, and the risk of infringement of such rights, are entirely their own responsibility.*

*This standard is subject to revision at any time by the responsible technical committee and must be reviewed every five years and if not revised, either reapproved or withdrawn. Your comments are invited either for revision of this standard or for additional standards and should be addressed to ASTM International Headquarters. Your comments will receive careful consideration at a meeting of the responsible technical committee, which you may attend. If you feel that your comments have not received a fair hearing you should make your views known to the ASTM Committee on Standards, at the address shown below.*

*This standard is copyrighted by ASTM International, 100 Barr Harbor Drive, PO Box C700, West Conshohocken, PA 19428-2959, United States. Individual reprints (single or multiple copies) of this standard may be obtained by contacting ASTM at the above address or at 610-832-9585 (phone), 610-832-9555 (fax), or service@astm.org (e-mail); or through the ASTM website (www.astm.org).*