



Designation: D 3370 – 95a (Reapproved 1999)<sup>e1</sup>

## Standard Practices for Sampling Water from Closed Conduits<sup>1</sup>

This standard is issued under the fixed designation D 3370; the number immediately following the designation indicates the year of original adoption or, in the case of revision, the year of last revision. A number in parentheses indicates the year of last reapproval. A superscript epsilon ( $\epsilon$ ) indicates an editorial change since the last revision or reapproval.

*This standard has been approved for use by agencies of the Department of Defense.*

<sup>e1</sup> NOTE—Footnotes were editorially removed in June 1999.

### 1. Scope

1.1 These practices cover the equipment and methods for sampling water from closed conduits such as process streams at power stations for chemical, physical, microbiological, and radiological analyses. It does not cover specialized equipment required for and unique to a specific test or method of analysis. The following are included:

	Sections
Practice A—Grab Samples	9 to 17
Practice B—Composite Samples	18 to 23
Practice C—Continual Sampling	24 to 29

1.2 For information on specialized sampling equipment, tests or methods of analysis, reference should be made to volumes 11.01 and 11.02 of the *Annual Book of ASTM Standards*, relating to water.

1.3 *This standard does not purport to address all of the safety concerns, if any, associated with its use. It is the responsibility of the user of this standard to establish appropriate safety and health practices and determine the applicability of regulatory limitations prior to use.* For specific hazards statements, see Note 5 and 13.4.

### 2. Referenced Documents

#### 2.1 ASTM Standards:

- A 106 Specification for Seamless Carbon Steel Pipe for High-Temperature Service<sup>2</sup>
- A 179/A179M Specification for Seamless Cold-Drawn Low-Carbon Steel Heat-Exchanger and Condenser Tubes<sup>2</sup>
- A 269 Specification for Seamless and Welded Austenitic Stainless Steel Tubing for General Service<sup>2</sup>
- A 335/A335M Specification for Seamless Ferritic Alloy Steel Pipe for High-Temperature Service<sup>2</sup>
- D 1066 Practice for Sampling Steam<sup>3</sup>
- D 1129 Terminology Relating to Water<sup>3</sup>

<sup>1</sup> These practices are under the jurisdiction of ASTM Committee D-19 on Water, and are the direct responsibility of Subcommittee D19.03 on Sampling of Water and Water-Formed Deposits, Surveillance of Water, and Flow Measurement of Water.

Current edition approved Sept. 10, 1995. Published November 1995. Originally published as D 3370 – 74 T. Last previous edition D 3370 – 95.

<sup>2</sup> *Annual Book of ASTM Standards*, Vol 01.01.

<sup>3</sup> *Annual Book of ASTM Standards*, Vol 11.01.

- D 1193 Specification for Reagent Water<sup>3</sup>
- D 3648 Practices for the Measurement of Radioactivity<sup>4</sup>
- D 3694 Practices for Preparation of Sample Containers and for Preservation of Organic Constituents<sup>4</sup>
- D 3856 Guide for Good Laboratory Practices in Laboratories Engaged in Sampling and Analysis of Water<sup>3</sup>
- D 4453 Practice for Handling of Ultra-Pure Water Samples<sup>3</sup>
- D 4515 Practice for Estimation of Holding Time for Water Samples Containing Organic Constituents<sup>4</sup>
- D 4840 Guide for Sampling Chain-of-Custody Procedures<sup>3</sup>
- D 4841 Practice for Estimation of Holding Time for Water Samples Containing Organic and Inorganic Constituents<sup>3</sup>
- D 5540 Practice for Flow Control and Temperature Control for On-Line Water Sampling and Analysis<sup>3</sup>

### 3. Terminology

3.1 *Definitions*—For definitions used in these practices, refer to Terminology D 1129.

#### 3.2 Definitions of Terms Specific to This Standard:

3.2.1 *back pressure regulator*—a device designed to maintain a constant pressure upstream of itself (variable or fixed back pressure regulators are available) to maintain constant flow in analyzers in continual sampling.

3.2.2 *composite sample*—a series of grab samples integrated into a single sample or a sample collected at specific time intervals and integrated into a single sample. The goal of a composite sample is to characterize a process weighted average in proportion to process parameters.

3.2.3 *grab sample*—a single sample from a process stream (flowing) or from a source of confined geometry (stagnant) withdrawn at a specific time. The goal of withdrawing a grab sample is to obtain a small portion of the process stream or confined geometry source in order to characterize the entire system.

3.2.4 *head cup*—a method used to achieve constant pressure (see *back pressure regulator*). It incorporates plumbing of the sample to a selected height above the inlet to the analyzer inlet line(s) to achieve the required inlet pressure for the analyzers. It is occasionally used downstream of colorimetric analyzers to

<sup>4</sup> *Annual Book of ASTM Standards*, Vol 11.02.

increase sample flow past the analyzer. The sample flows to an open cup with an overflow. This fixed head provides the constant pressure, assuming inlet flow to the head cup exceeds outlet flow to the grab sample and analyzers.

NOTE 1—Contemporary designs of back pressure regulators provide excellent sensitivity to pressure change and have limited the need for head cups and the concurrent space and maintenance problems as well as sample contamination potential.

3.2.5 *pressure reducer*—a device designed to reduce pressure, and therefore control flow, of sample to a pressure level where it can be regulated easily. This device shall be located downstream of the cooled sample where cooling is required.

3.2.6 *sample cooler*—a small heat exchanger designed to provide primary or secondary cooling, or both, of small process sampling streams of water or steam.

3.2.7 *time response*—the time required for the system to reach 63.2 % of the total change between the state of initial equilibrium in response to a step change introduced at the input to the system.

3.2.8 *variable rod in tube orifice*—a type of pressure reducer for high pressure samples that uses a retractable tapered rod inside a reamed tube to provide a variable orifice for pressure reduction that is parallel with the sample flow. This eliminates wear of the orifice and provides variable pressure reduction and flow.

#### 4. Summary of Practices

4.1 These practices include three procedures for sample collection. The first is for the collection of a grab sample of water at a specific site representing conditions only at the time of sampling. Grab sampling is the only procedure suitable for bacteriological analysis and some radiological test procedures.

4.2 The second practice is for collection of a composite sample at a specific site, portions of which are collected at varied time intervals. Alternatively, the composite may consist of portions collected at various sites or a combination of both site and time variables.

4.3 The third practice provides a continuously flowing sample from one or more sampling sites, suitable for on-line analyzers or for collecting grab samples from a continuously flowing sample stream.

#### 5. Significance and Use

5.1 The goal of sampling is to obtain for analysis a portion of the main body of water that is representative. The most critical factors necessary to achieve this are points of sampling, and materials selection, system design, time of sampling, frequency of sampling, and proper procedures to maintain the integrity of the sample prior to analysis.

5.2 Homogeneity of the process to be sampled is frequently lacking, necessitating multiple-point sampling. If it is impractical to utilize a most-representative sampling point, it may be practical to determine and understand interrelationships so that results obtained at a minimum number of points may be used to characterize the system.

5.3 Samples collected from a single point in a system are always recognized as being non-representative to some degree. For this reason, total representativeness of samples cannot be a

prerequisite to the selection of a sampling point. The degree of representativeness of the sample shall be assessed and the assessment made a part of the permanent record. This will prevent an artificial degree of accuracy from being assigned to the data derived from tests on the sample.

5.4 The samples shall be of sufficient volume and shall be taken frequently enough to permit reproducibility of testing requisite for the desired objective, as required by the method of analysis to be used.

5.5 Laboratories or facilities conducting water sampling should be in compliance with Guide D 3856.

#### 6. Interferences

6.1 If chemicals are injected or other streams are introduced into the medium to be sampled, the sample collection point should be placed far enough downstream to ensure a completely mixed sample. Assuming turbulent flow (for example, a Reynolds number of at least 4000), locating the sample collection point an equivalent length of 25 diameters downstream of the chemical injection point is considered acceptable. An equivalent length of 50 diameters is recommended for laminar flow.

6.2 The sampling of high-purity water requires special consideration. Contact with any material other than the original container subjects the sample to possible contamination or alteration. This includes contact with air. Additional requirements are given in Practice D 4453.

#### 7. Materials and Apparatus

##### 7.1 *Sample Lines:*

7.1.1 *General*—Sample lines should be designed so that the sample is representative of the source. They shall be as short as feasible and of the smallest practicable bore to facilitate flushing, minimize conditioning requirements, reduce lag time and changes in sample composition, and provide adequate velocity and turbulence. The lines shall have sufficient strength to prevent structural failure. The designer is responsible for ensuring that applicable structural integrity requirements are met. Small tubing is vulnerable to mechanical damage and should be protected.

7.1.1.1 Traps and pockets in which solids might settle shall be avoided, since they may be partially emptied with changes in flow conditions and may result in sample contamination. Sample tubing shall be shaped so that sharp bends, dips, and low points are avoided, thus preventing particulates from collecting. Expansion loops or other means shall be provided to prevent undue buckling and bending when large temperature changes occur. Such buckling and bending may damage the lines and allied equipment. Routing shall be planned to protect sample lines from exposure to extreme temperatures.

NOTE 2—Studies (1–5)<sup>5</sup> on particle transport in sampling lines have indicated that sample velocity rate and stability are important factors in determining deposition and erosion rates on sample tube walls and time required to reach and maintain equilibrium. Although limited, other work has also noted effects of sorption of dissolved species within tube wall

<sup>5</sup> The boldface numbers in parentheses refer to the list of references at the end of this standard.

deposits. Velocities near 1.8 m/s (6 f/s) seem to optimize these factors, but, other velocities can provide acceptable results. Sample velocity should be considered as a key design issue along with type of sample, lag time, pressure drop, new or existing sample lines, etc. when determining sample flow rates. Maintaining the selected velocity is necessary to achieve sample representivity.

**7.1.2 Materials**—The material from which the sample lines are made shall conform to the requirements of the applicable specifications as follows:

	ASTM Designation
Pipe (seamless carbon steel for high-temperature service)	Specification A 106
Pipe (seamless ferritic alloy-steel for high-temperature service)	Specification A 335
Tubing (seamless carbon-steel for high-temperature service)	Specification A 179
Tubing (seamless or welded alloy-steel for high-temperature service)	Specification A 269
Tubing, Plastic (polyethylene), or equivalent non-leaching inert materials	

Carbon steel pipe or tubing may be satisfactory for sampling lines where levels of contaminants in the sample are high, or sample constituents require it. For sampling high-purity waters or corrosive waters, the sampling lines shall be made of stainless steel that is at least as corrosion resistant as 18 % chromium, 8 % nickel steel (AISI 304 or 316 austenitic stainless steels are commonly used (6).

**NOTE 3**—Plastic tubing should be avoided where low values of dissolved oxygen are to be measured since atmospheric gases may diffuse through the tubing and cause an analytical bias. The selection of the sample line material should be based on the parameters of interest.

## 7.2 Valves and Fittings:

**7.2.1 Materials**—Valve and fitting materials should be compatible with the sample and the sample line material selected. AISI 316 austenitic stainless steel is commonly used. Pressure and temperature ratings should be selected based on the specific service of the valve/fitting.

**7.2.2 Isolation Valves**— At least one shut off valve (commonly referred to as a root valve) shall be placed immediately after the point from which the sample is withdrawn so that the sample line may be isolated when desired. For safety purposes, an isolation valve should be placed at the sample cooler inlet (if used) and be rated in accordance with the pressure and temperature of the sample source.

**7.2.3 Pressure Reducers**—The pressure reducer, in combination with properly sized sample lines, is the primary component necessary to control the sample flow at the rates required to give the most representative sample (see Note 2). Flow control is accomplished at the same time sample pressure is reduced.

**7.2.3.1** For samples equal to or greater than 500 psig (3447 kPa), the pressure reducer shall be a rod-in-tube type orifice or capillary (variable or fixed). Variable rod-in-tube devices are recommended since they offer two advantages: (a) they are capable of varying the pressure drop and, therefore, the flow; and (b) they are cleanable in place (exercising the position of the tapered rod in the tube). Forepressure regulators are not recommended for large pressure reductions because of susceptibility to erosion, plugging, and wire drawing of the stem or seat.

**7.2.3.2** For samples less than 500 psig (3447 kPa), the pressure reducer shall be a needle valve or forepressure regulator. A needle valve is preferred since it will not hunt with small pressure variations.

**7.2.4 Pressure Regulators**—Since most on-line analyzers are flow sensitive, as well as temperature sensitive, the flow rate in the branch circuits shall also be controlled to ensure repeatable analytical results. This is achieved by establishing a constant pressure zone where the sample line feeds the analyzer branch lines. See Practice D 5540 for additional information. Because of the relationship of pressure and flow, a zone of constant pressure will ensure that each analyzer fed from this zone gets a constant flow rate independent of actions taken in the other branch lines while maintaining constant flow in the main sample line. Maintaining constant flow is also essential in regularly monitored grab samples. Two methods are available to achieve this constant pressure zone in conjunction with the upstream pressure reducer: ( 1) back pressure regulator (fixed or variable) or ( 2) head cup. Using a forepressure regulator without a back pressure regulator or head cup is not recommended. A forepressure regulator alone will not provide a constant sample line flow. Flow changes in the branch lines below the regulator result in the forepressure regulator closing or opening to maintain the analyzer inlet pressure thereby changing the main sample line flow and disrupting the representivity of the sample from its source.

**7.2.4.1** Use of a back pressure regulator is the preferred method to achieve the constant pressure zone. Total sample flow is established using the primary pressure reducer with all flow going through the back pressure regulating valve to drain, recovery, or for grab sample. The regulating valve establishes a fixed pressure at the valve inlet. Branch lines to each analyzer are connected to this fixed pressure zone. When flow is initiated to an analyzer, the back pressure regulator will close slightly to maintain the pressure at the regulator inlet. Similarly, when flow to an analyzer is shut off, the regulator will open to accommodate the increased flow. Since the pressure at the branch connections to the other analyzers is maintained constant, their flow is not affected by changes of flow to other analyzers.

**7.2.4.2** A head cup works in a similar way. Full flow from the pressure reducer flows up a vertical tube to a trough. The overflow goes to drain or recovery. The analyzer branch line(s) is connected at the bottom of the vertical tube. When flow is established through the analyzer, the flow up the vertical tube is reduced that same amount. To avoid sample contamination, the trough must overflow at all sampling conditions. The head cup can be used in pure water applications when clean atmospheric conditions exist. However, some analyses (pH, conductivity, and dissolved gases) can be affected by dissolved gas contamination as the sample is exposed to the atmosphere.

**7.2.5 Other Valves**— Blowdown/flushing valves may be used to purge sample lines that are not in continuous service and can be located prior to or after the roughing or primary sample cooler. Other valves should be selected based on specific requirements, for example, analyzer flow metering, secondary isolation, grab sampling, etc. In sampling systems with on-line analyzers, selecting a ball valve for grab sample

use without a flow metering valve in series with it can starve the constant pressure zone created by the back pressure regulator/head cup and disrupt sample flow. Systems shall be provided with a method to protect components from overpressurization. Acceptable methods include suitable back pressure regulator with built in relieving capacity, head cup, or suitable relief valve.

**7.2.6 Fittings**—If feasible, bends rather than fittings should be used to change direction of sample tubing. Compression or socket weld fittings can be selected for sample lines. Because improperly welded joints are susceptible to plugging by suspended solids, compression fittings are preferred. The ends of cut tubes shall be ream cut to restore the full bore of the pipe diameter. If not installed properly, both socket weld and compression fittings can include fine annuli between tube and fittings that may hold contaminants.

**7.3 Sample Cooler or Condenser:**

**7.3.1** High efficiency sample coolers or condensers used for primary temperature reduction/condensation shall be capable of normally reducing the incoming sample temperature to within 5°F (2.8°C) of the cooling water inlet temperature for water samples and 10°F (5.6°C) of the cooling water inlet temperature for steam samples at sample flows that are sufficient to provide a representative sample (refer to 7.1.1). Cooling water requirements should be as low as possible but shall not exceed 12 g/m (2.7 m<sup>3</sup>/h) per cooler except for very large sample flows (1 g/m (0.3 m<sup>3</sup>/h)). Sample coolers used for secondary cooling shall be capable of a 1°F (0.5°C) approach to the chilled water temperature when the primary cooler is specified as detailed above. The tube through which the sample will flow shall be one continuous piece and shall extend completely through the cooler without deformation so there is no possibility of sample contamination or dilution from the cooling water. The tube shall be of sufficient strength to withstand the full pressure and temperature of the fluid being sampled.

**7.3.2** The cooler or condenser tube shall be made of stainless steel that is at least as corrosion resistant as 18 % chromium, 8 % nickel steel. Specific water chemistry could dictate different materials for improved corrosion resistance, for example, Alloy 600 for high chlorides. The diameter of the tube shall be as small as practicable based on representative sample flows so that storage within the coil is low and the time lag of the sample through the cooler is minimal.

**7.3.3** Fig. 1 and Fig. 2 show typical sample coolers. Fig. 1 is a helical coil heat exchanger with removable one-piece shell type sample cooler. Fig. 2 is a double concentric helical coil, or tube within a tube type sample cooler. The portion of the sample cooler (shell or outer tube) containing the cooling water should provide for adequate cooling water velocity to achieve required sample cooler efficiency as noted above and be made of material that is corrosion resistant to the cooling water in use. Materials that have corrosion resistance to the ambient atmosphere around the sample cooler itself should also be considered in order to avoid exterior corrosion, pitting, etc., on the sample cooler.

**NOTE 4**—The scaling/fouling tendencies of the cooling water available should be given careful consideration when selecting a sample cooler or

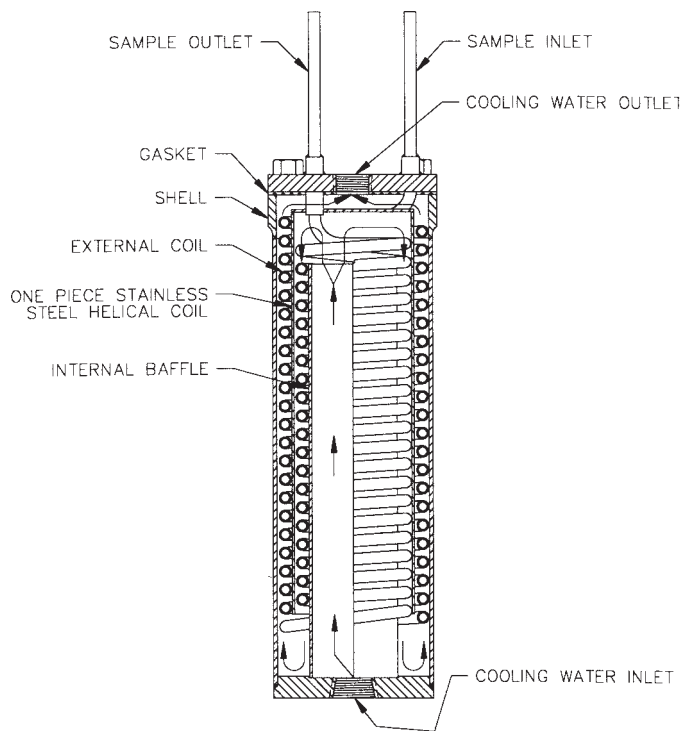

**FIG. 1 Helical Coil Heat Exchanger with Removable Shell**

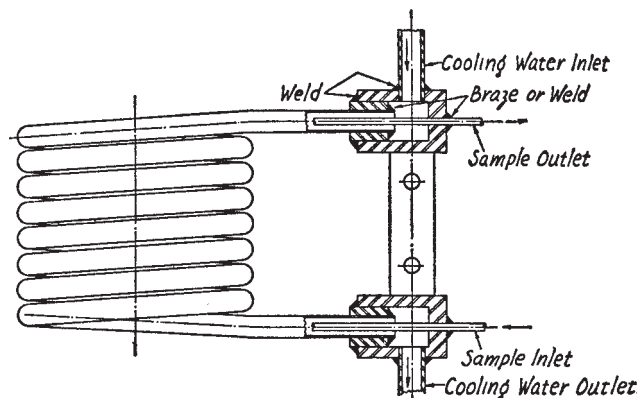

**FIG. 2 Double-Tube Helical Coil Heat Exchanger**

condenser. Water that is extremely hard or contains considerable slime or algae or suspended solids may cause rapid fouling of the cooling water side of the cooler, such that its efficiency may be seriously impaired. If it is necessary to use such a cooling water, the sample cooler should be one that can be cleaned readily and effectively with the least possible delay, for example, submerged helical coil in shell sample cooler (see Fig. 1). Concentric (tube in tube) type coolers (see Fig. 2) are subject to plugging and fouling.

**7.4 Flow Meters**— A visual means of reading main and branch sample line(s) flow shall be used. Rotameters or other mechanical or electronic flow measuring devices are recommended. This is the only way to ensure that the sample is flowing at a velocity that assures a representative sample. Refer to 7.1.1.

**7.5 Sample Filters**— Use of sample filters to remove suspended solids such as metal oxides can dramatically change the analytical results. Metal oxides react with other chemicals in water and steam (6) and change the ratio of the total/

dissolved chemicals. Use of sample filters should, therefore, be evaluated with respect to analytical and control requirements.

7.6 *Pumps*—Withdrawing of a water sample under subatmospheric pressure may require the use of pumps. Small centrifugal pumps with casing or suction side vent to the source, magnetically coupled gear pumps, or diaphragm pumps may be used. Pumps employing built in filters should have them removed. The suction sampling line shall be sloped downward over its entire length without pockets to avoid gas binding. Consideration shall be given to possible contamination of the sample due to pump material depending on the particular constituents to be analyzed. Also, consideration shall be given to ensure that the pump is designed to handle low net positive suction head (NPSH) which is typically seen in subatmospheric samples.

7.7 *Sample Probes, Nozzles, and Isokinetic Sampling:*

7.7.1 Multiport and single-port nozzles can be used to obtain representative samples from process streams. Liquid samples may be extracted from the side of horizontal piping runs. Single-port taps are adequate if sufficient velocity is maintained to avoid deposition, whereas multiport nozzles are recommended for obtaining samples containing suspended matter. Multiport nozzles can be provided to extend across a pipe diameter to obtain an average sample of a cross section. Fig. 3 illustrates a single-port sampling nozzle. The impact of sample probe failure on process equipment damage should be considered.

7.7.2 Because of varying sizes and densities of particles, samples shall be withdrawn from a flowing stream in a manner that the velocity of the sample in the nozzle tip is equal to the velocity of the fluid approaching the nozzle. If the velocity of the sample in the nozzle is greater than that of the fluid

approaching the nozzle, the concentration of particles will be less than that in the process fluid, whereas the opposite occurs when the fluid velocity in the nozzle is less than that approaching the nozzle. When the velocity of the fluid in the nozzle is equal to that of the fluid approaching the nozzle, isokinetic sampling is provided. Isokinetic sampling is required when two phases which have different densities are present and is recommended for corrosion product sampling.

7.7.3 Caution should be used in designing sample probes and nozzles. Corrosion product or sediment (crud) deposits are greater on tees than on other tubes, and deposition is linearly proportional to the length of sample tube (7). Thus, sample collection points should be as close to sample probes and nozzles as practicable.

7.8 *Degassers*—Degassers shall be made of corrosion-resistant materials similar to materials described in 10.1. The degassers shall be designed to take the full flow required for representative sampling as described in Practice D 1066. The piping ahead of the degasser shall be arranged so that none of the sample is diverted from the degasser.

7.9 *Sample Containers*—Sample containers shall be made of materials that will not contaminate the sample and, before use, shall be cleaned thoroughly to remove all extraneous surface dirt. Chemically resistant glass and polyethylene are suitable materials for the containers. The closures for the sample containers shall be glass stoppers that have been thoroughly washed, or plastic caps with suitable liners. See Practices D 3694 and D 4453 for additional information. Sample containers shall be made of materials that will not contaminate the sample and shall be cleaned thoroughly before use to remove all extraneous surface contamination. The particular constituents to be analyzed will determine specific cleaning practices for sample containers. Generally, chemical cleaning agents are not used for containers used to collect trace constituents. Chemically resistant glass and rigid and collapsible plastic containers of polyethylene and polypropylene are suitable. Some plastic containers are not suitable for samples collected for organic analyses. Sample containers for high purity water should be in accordance with Practice D 4453.

7.9.1 The collection, storage, and subsequent analytical determination in plastic containers will result in erroneous pH values or dissolved oxygen as a result of the permeability of plastic to gases such as carbon dioxide and oxygen if the sample is stored for an excessive period prior to analysis. The user is responsible for determining such effects on analysis results.

7.9.2 The closures for the sample containers shall be glass stoppers that have been thoroughly washed, or plastic or metal caps with suitable liners. Only PTFE or aluminum foil are suitable as cap liners for samples to be analyzed for organic constituents.

7.9.3 Wash sample containers with soap or biodegradable detergent if required. Rinse bottles that have contained samples with chromate or heavy metals with dilute nitric acid solution before final, thorough rinsing with reagent water. Dry by draining.

7.9.4 For most bacteriological samples, provide wide-mouth sample bottles of sufficient capacity. The bottles may be of

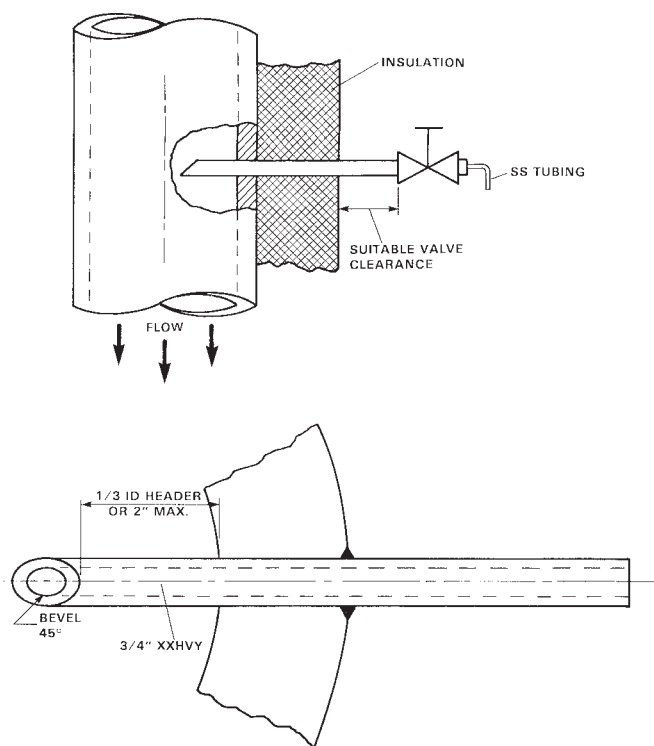

FIG. 3 Water Sampling Nozzle (3)



borosilicate glass or other material resistant to the solvent action of water. Metal or plastic wide-mouth screw caps may be used on sample bottles. Bottles, caps, and their liners shall be capable of withstanding sterilization temperatures (commercially available sterile bottles may be used). They shall produce no compounds by volatilization during sterilizing, and they shall impart no toxic or bacteriostatic compounds to the water sample.

7.9.4.1 Dedicate appropriate sample bottles for microbiological use. Wash bottles with hot detergent water and a brush. Rinse well with Type B reagent water.

7.9.4.2 Loosen the screw caps slightly to prevent possible rupture of the container during sterilization. Sterilize the bottles in a hot-air oven at a minimum of 170°C for at least 1 h or autoclave at 121°C for 15 min.

7.9.4.3 Add Na<sub>2</sub>S<sub>2</sub>O<sub>3</sub> (refer to 8.4) in an amount sufficient to provide a concentration of approximately 100 mg/L in the sample if the samples to be taken contain residual chlorine.

7.9.5 When organic constituents are to be determined, refer to Practice D 3694.

7.9.6 Virgin sample containers are recommended for trace constituents unless the same system will be sampled on a routine basis and the constituents to be analyzed do not show large variations.

7.10 *Sample Labels*— Space shall be provided for the following information on an etched area of the bottle, a gummed label, or a cardboard or linen tag securely affixed to the container:

7.10.1 Sample number,

7.10.2 Date and time of sampling,

7.10.3 Source of sample,

7.10.4 Point of sampling (designated in sufficient detail to enable anyone to collect a second sample from the identical spot from which the first sample was taken),

7.10.5 Temperature and rate of flow of the fluid in the equipment from which the sample was taken,

7.10.6 Temperature of sample,

7.10.7 Results of field tests made on the sample, and

7.10.8 Signature of sampler.

7.11 *Sample Shipping Containers*—The stoppers closing the sample containers shall be fixed in place by wire, tape, or cord to prevent leakage in transit. The sample containers shall be of such size that when filled with the desired amount of sample, space roughly equivalent to 1 % of the volumetric capacity of the containers will be available for expansion of the liquid. The sample shipping container shall be a case having a separate compartment for each sample container. The compartment around each container shall be lined with corrugated paper or other suitable material, with the containers held in place with spring clips; or an elastic packing material may be used.

7.12 *Shipping Labels*— The addresses of consignee and consignor shall be plainly printed upon two sides of the outer container, or attached firmly thereon by cards or labels. Warning and descriptive labels shall be attached to the outer container, such as “Fragile,” “Liquid,” “Glass,” etc., when applicable. In cold weather, the label “Keep from Freezing” shall be attached to the outer container.

## 8. Reagents

8.1 *Purity of Reagents*—Reagent grade chemicals shall be used. Unless otherwise indicated, it is intended that all reagents shall conform to the specifications of the Committee on Analytical Reagents of the American Chemical Society, where such specifications are available.<sup>6</sup> Other grades may be used, provided it is first ascertained that the reagent is of sufficiently high purity to permit its use without lessening the accuracy of the determination.

8.2 *Purity of Water*— Reference to water shall be understood to mean Type II reagent water conforming to Specification D 1193. When bacterial levels need to be controlled, Type B requirements of Specification D 1193 are generally adequate.

8.3 *Dilute Nitric Acid Solution (1 + 4)*—Mix 1 volume of concentrated nitric acid (HNO<sub>3</sub>, sp gr 1.42) with 4 volumes of water.

NOTE 5—**Warning:** Concentrated nitric acid is a strong oxidant. Contact with other materials may cause fire. It may cause delayed burns or external ulcers. Keep the container closed when not in use. Do not get the acid in the eyes, on the skin, or on clothing. Vapors are extremely hazardous; do not breathe them. Use only in a hood. In case of contact, immediately flush the skin or eyes with water for 15 min. If contact with the eyes occurs, obtain medical attention immediately after flushing.

8.4 *Sodium Thiosulfate*—(Na<sub>2</sub>S<sub>2</sub>O<sub>3</sub>), powdered.

8.5 *Detergent*, suitable for cleaning sample bottles.

## PRACTICE A—GRAB SAMPLES

### 9. Scope

9.1 This practice is applicable to sampling water from closed conduits such as pipelines, process streams, processing tanks and vats, and steam generators for chemical, physical, bacteriological, or radiological analyses.

9.2 A grab sample represents the conditions existing only at the point and time of sampling.

### 10. Frequency and Duration of Sampling

10.1 Water undergoing continuous or intermittent treatment shall be sampled with such frequency that adequate control is assured. The interval between samples is directly related to the rate at which critical characteristics can reach intolerable limits. In general, samples should be collected at a frequency which will ensure that process parameters are adequately characterized. Continuous sampling or composite sampling may be required if a single grab sample cannot characterize the process.

### 11. Points of Sampling

11.1 Choose sampling points with regard to the piping and configuration of the individual piece of equipment containing the water to be tested, the character and changes occurring between the inlet and outlet water, and rate of passage through

<sup>6</sup> *Reagent Chemicals, American Chemical Society Specifications*, American Chemical Society, Washington, DC. For suggestions on the testing of reagents not listed by the American Chemical Society, see *Analar Standards for Laboratory Chemicals*, BDH Ltd., Poole, Dorset, U.K., and the *United States Pharmacopeia and National Formulary*, U.S. Pharmaceutical Convention, Inc. (USPC), Rockville, MD.

the equipment. Ensure that a representative sample is obtained by allowing mixing to take place.

11.2 The exact point of sampling water in steam generators depends on design, location of chemical and feedwater lines, and other local conditions. A special sampling nozzle is the most desirable for taking a sample, however, a properly located, continuous blowdown line may serve as a satisfactory substitute. The blowdown line may not be a suitable source for a boiler water sample during periods of blowdown isolation because sample flow during isolation periods will be the only flow through the blowdown line. Locate nozzles or sampling tubes at points remote from confining surfaces and in a submerged position. In selecting the location for nozzles and sampling lines, avoid the possibility of unseparated steam inclusion, excessive amounts of particulate matter, incoming feedwater, and added chemicals. Significant variation in the composition of the water sample may exist throughout the steam generator. For this reason, samples taken from several locations simultaneously may be desirable.

11.3 When the water to be sampled is confined at low or subatmospheric pressure, provide special means to extract the sample (refer to 7.6).

11.4 When sampling a stagnant tank, the contents should be adequately mixed to ensure homogeneity. If a recirculation pump is to be used for mixing, a volume equivalent to three tank volumes should be pumped prior to withdrawing a sample.

## 12. Conditioning Requirements

12.1 *Regularly Monitored Grab Samples*—Samples that are regularly monitored should flow continuously. Refer to Section 7 and Practice D 5540.

12.2 *Periodic Grab Samples*—Intermittent sampling points with sample lines used for troubleshooting of process streams should be used as follows. Before collection of the sample, the lines should be flushed for a minimum of three sample line volumes at a sample flow rate of approximately 125 % of normal sample velocity. Refer to 7.1.1. After flushing, set the sample flow rate as appropriate, rinse the sample container and closure, and take the sample. Intermittent sample points directly connected to the process stream, vat, tank, etc. should have low dead volume in the sampling apparatus upstream of the collection interface. Flush the sample apparatus to eliminate any dead volume, rinse the sample container and closure, and take the sample.

### 12.3 *Temperature and Pressure Adjustment:*

12.3.1 When samples require temperature adjustment, use a sample cooler to adjust the sample to approximately the required temperature. Refer to 7.3.

12.3.2 When samples require pressure adjustment, use appropriate pressure reducers or regulators, or both. Refer to 7.2.3 and 7.2.4.

12.3.3 Temperature and pressure adjustment may alter the characteristics of the sample from its original state (8), (9).

## 13. Sample Collection

13.1 *Volume of Sample*—Consult the specific method of analysis for any given constituent to determine the volume of

sample required. Frequently the required volume will vary with concentration level of any given constituent.

### 13.2 *Handling and Storage:*

13.2.1 When sampling ultra-pure water samples, observe recommendations given in Practice D 4453. Contamination can occur during sample collection, during sample storage by leaching of improperly cleaned containers, during sample transfer, and by handling with pipets, syringes, etc., and during the actual analysis by contaminated reagents, sample cells, and loop systems.

13.2.2 When sampling water from isolated cocks or valves, insert the sample line (or a thoroughly washed glass tube, an inert plastic tube, or sulfur-free rubber tube extension of the sample line) into the sampling container so that it touches the bottom. Allow a volume of water equal to at least ten times the volume of the sample container to flow into and overflow from the container before the sample is taken.

NOTE 6—If the sample is to be tested for constituents that may be adsorbed on the wall of the sample container, do not rinse the container and do not overflow it during sample collection. Oil, grease, and PCBs are typical constituents in this category.

13.2.3 If a preservative or additive has been added to the sample container, allow the sample to free fall into the container and do not allow it to overflow.

13.2.4 If contact with air would cause a change in the concentration or characteristics of a constituent to be determined, secure the sample without contact with air and completely fill the container.

13.2.5 When samples are to be shipped, do not fill the bottle entirely in order to allow some room for expansion when subjected to a change in temperature. An air space of 5 % usually suffices for this purpose, although this does not protect against bursting of the container as a result of freezing. This precaution precludes shipping samples for analysis of constituents in high purity samples and those noted in 13.2.4.

NOTE 7—Samples collected for the analysis of volatile constituents should be filled to the top, otherwise, analyte loss may occur.

13.2.5.1 An alternative method to provide room for expansion and eliminate contact with air is to use a flexible, plastic sample container. Fill the container completely, compress it to exclude approximately 5 % of the contents, and replace the cap before the pressure is released.

13.2.6 When sampling water from steam generators, take precautions to avoid dilution by condensed steam or concentration resulting from “flashing.” Condition sample in accordance with 7.1 to 7.3 and Practice D 5540.

13.2.6.1 Before taking the sample, rinse the sample container at least three times by filling it to one fourth of its capacity with water to be sampled, shaking the container, then emptying. Refer to Practice D 4453 for collecting high-purity water samples.

13.2.6.2 Collect the water sample by upward displacement through a tube extending to the bottom of the container. For samples containing constituents which do not adsorb on the sample container walls, allow the container to overflow at least five times its volume and then stopper the container with a stopper previously rinsed with the sample water. If analysis

cannot be made immediately, the container should be tightly stoppered to prevent atmospheric contamination.

13.2.6.3 Since concentrations of constituents vary at different water levels or ratings and are influenced by the amount of water, take all samples when the water is at normal operating level, unless there is a specific reason for sampling under other conditions. For comparative testing under abnormal conditions, take samples at similar rating and similar water levels to avoid dilution or concentration resulting from changes in the amount of water in the steam generator.

### 13.3 *Microbiological Samples:*

13.3.1 When taking a sample from a sample line or tap from the entire part of the system that has been stagnant for 2 h or more, allow the water to run for at least 5 min or long enough to flush three to ten times the line volume. When sampling for sulfate-reducing bacteria, use the initial water from the sample line or tap.

13.3.2 Choose a sterile sample bottle containing approximately 100 mg/L  $\text{Na}_2\text{S}_2\text{O}_3$  if the water being sampled contains residual chlorine, has been chlorinated, or contains any free or combined available oxidizing agent intended to sterilize it. If such sterilizing agents are not present, the thiosulfate may be omitted. In cases where thiosulfate interferes with subsequent examination, such as examination for sulfate-reducing bacteria, etc., omit the use of thiosulfate in the sample bottle even if such sterilizing agents are present. In this case, if such sterilizing agents are present, the examination shall be performed as soon as feasible.

13.3.3 Remove the stopper from the sample bottle. Grasp the stopper by the dust cover so as not to contaminate it by touching it. Do not lay it down. Keep fingers dry or wear plastic or rubber gloves to minimize contamination of high-purity waters. Hold the bottle by the bottom to avoid touching the neck. Do not rinse the bottle with the sample. Quickly hold the bottle under the flowing water to be sampled until it is about three-fourths full to permit mixing by shaking prior to testing. Replace the stopper and promptly crimp the dust cover in place over the neck of the bottle. Take care that the stopper and the bottle neck are not touched during this operation and that no dust blows into the bottle, insofar as possible.

### 13.4 *Radioactive Water Samples:*

13.4.1 Because of the potential hazards related to working with water containing radioactive nuclides, special handling of radioactive samples may be required. Information on radiological hazards and recommendations on radiation protection have been published by the National Council on Radiation Protection and Measurements, NCRP (10). Holders of U.S. Nuclear Regulatory Commission Licenses are limited by regulations published in Title 10 of the Code of Federal Regulations, Part 20 (11). Personnel handling radioactive material shall be familiar with and use safe practices in handling radioactive material and shall be in compliance with all applicable federal, state, and local regulations.

13.4.2 When sampling process water where radioactivity levels may be high, such as nuclear reactor cooling waters, follow applicable health physics regulations. In such cases, the use of suitable protective clothing may be required. Personnel-monitoring devices may be necessary when external radiation

levels present a potential hazard. If the level of radioactivity in the sampling area is sufficiently great to introduce a radiation hazard, shielding for sample lines, coolers, and collection devices may be required to minimize exposure to radiation. Exercise precautionary measures to prevent contamination and spread of radioactivity by spillage of samples or by leakage or breakage of sampling lines, valves, containers, etc. In addition, take precautions to prevent release of gaseous or airborne radioactive substances, thereby minimizing the hazard to the individual collecting the sample.

13.4.3 When sampling water-cooled and moderated reactors at power plants, a shielded delay coil is normally installed between the reactor loop and the sample point. The delay coil is of suitable length to provide for decay of nitrogen-16.

13.4.4 If sample containers are to be shipped, shield and pack to comply with regulations for shipping radioactive materials (12).

13.4.5 Procedures for collecting the sample should, in general, follow those described in 13.2.

13.4.6 When the water sampled is under pressure and contains gaseous radioactive substances, the container employed should be designed to prevent any disproportionate loss of the gases during sampling, unless the gaseous radioactive material will not be analyzed.

13.4.7 Employ suitable measures to minimize adsorptive materials which may already be on the surfaces of whatever particulate matter is present. In such cases, treatment to prevent adsorption may result in undesired transfer of radionuclides from the suspended to the dissolved phase.

## 14. **Particulate Matter**

14.1 Normally, samples are taken without separation of particulate matter. If constituents are present in colloidal or flocculent suspension, take the sample so that the material is present in representative proportion. Refer to 7.1.1 for sample velocity recommendations and 7.7 for recommendations on sample probes, nozzles, and isokinetic sampling.

14.2 *Corrosion Product Samples*—Samples containing trace levels of metallic constituents can be collected on filter or ion exchange material, or both, in a high-flow-rate bypass sampling system. Ensure that the capacity of the ion exchange media is not exceeded during sample collection. Retention efficiency shall also be determined to ensure that sample collection is adequate. Suspended material is collected on a filter upstream of the ion exchange material. The ion exchange material can be eliminated if only particulates are to be sampled. The sample is normally collected for three to seven days prior to changing the filter of ion exchange material.

14.3 Particular considerations shall be given when sampling systems for copper corrosion products. Low flow rates, high copper levels, high percent insoluble copper, reducing environment, high sulfides, or large temperature gradients will promote copper deposition. Metallic copper can be formed by reducing copper ions by iron. In-line nitric acid injection can be used to minimize copper deposition in sample nozzles, sample lines, and heat exchangers (13).

## 15. Preservation of Samples

15.1 The use of chemical preservatives and maximum holding times may be established by regulatory agencies. Samples collected should meet regulatory agency requirements and good practices for holding times and the use of chemical preservatives. Note any preservatives added to the sample on the label.

15.2 Quick freezing is beneficial in preserving some organic constituents, however, aldehydes and oxygen demand samples can be severely affected by freezing. Samples collected for biological examination should be refrigerated or packed in ice or freeze packs. If freezing is used, the user should verify that the quality of the sample is not degraded.

15.3 Chemical treatment of radioactive samples to prevent biological or algae growth is not recommended per Practices D 3648 and should be avoided unless essential. When necessary, reagents used should not chemically react with the radioactive species in the sample.

15.4 For preserving high-purity water samples, refer to Practice D 4453.

15.5 Special precautions should be taken for light-sensitive samples such as using amber or opaque sample containers or storing the samples in a light-free cabinet.

## 16. Time Interval Between Collection and Analysis of Samples

16.1 In general, allow as short a time as possible to elapse between the collection of a sample and its analysis. Under some conditions, analysis in the field is necessary to secure reliable results. The actual time that may be allowed to intervene between the collection and analysis of a sample varies with the type of examination to be conducted, the character of the sample, and the time interval allowable for applying corrective treatment. An acceptable method for estimating maximum holding times is given in Practices D 4515 or D 4841, as appropriate.

16.1.1 Hold samples for microbiological analyses for the least time possible from collection to analysis or incubation, as appropriate. Consider field examination if time limits cannot be met.

16.2 On the statement of an analysis, specify the length of time elapsed between collection and analysis of the sample.

16.3 Make the determination of dissolved gases, such as oxygen, hydrogen sulfide, and carbon dioxide at the source, except that in some cases such constituents may be fixed and determined later as specified in the specific test methods.

16.4 When sampling for radionuclide determinations, note the exact time of sample collection. If short-lived activity is of interest, analysis should be made as rapidly as practical to minimize loss of activity by radioactive decay. If only long-lived activity is of interest, measurement of the radioactivity sometimes can be simplified by allowing sufficient time before analysis for the decay of the short-lived radionuclides.

## 17. Transportation of Samples

17.1 Fix the stoppers closing the sample containers in place by wire, tape, or cord to prevent leakage in transit as appropriate.

17.2 The sample shipping container shall be a case having a separate compartment for each sample container. Line the compartment around each sample container with corrugated paper, felt, or similar material, or hold the sample containers in place with spring clips, foamed plastic, or similar material. Use insulated containers for quick-frozen samples, maintaining the temperature of the sample, as appropriate.

17.3 Recommended practices regarding chain of custody are given in Practice D 4840.

17.4 Sample containers which are packed in ice or cooled by freeze packs should be sealed in plastic bags to ensure sample integrity. Remove air from plastic bags containing samples to ensure good contact for heat transfer.

17.5 Print the addresses of consignee and consignor plainly upon the outer container, or attach firmly thereon by cards or labels. Attach warning and descriptive labels on the outer container, such as “Fragile,” “Liquid,” “Glass,” “Radioactive,” “Handle with Care,” “This Side Up,” etc., when applicable. In cold weather, attach the label “Keep from Freezing” to the outer container, except for those samples which are intentionally frozen.

## PRACTICE B—COMPOSITE SAMPLES

### 18. Scope

18.1 Composite sampling is applicable for subsequent chemical and physical analysis. It may not be suitable for sample collection for radiological examination, particularly for short-lived radionuclides. NRC Regulatory Guide 1.21 discusses composite sampling of radioactive material in liquid and gaseous effluents from light-water-cooled nuclear power plants (14).

18.2 Composite samples are not suited for bacteriological examination. Composite sampling for waters containing volatile constituents should be accomplished with minimum loss of analytes.

### 19. Frequency and Duration of Sampling

19.1 If the process is cyclic in nature, collect samples during the part of the process cycle that is important to the parameter of interest. Collect increments for composite samples at regular intervals and in proportion to the rate of flow of the water. Choose a suitable factor to give the proper volume (for example, 4L) for the composite sample.

19.2 When samples are taken from a process stream, composite samples for analysis normally consist of equal quantities of daily samples for a suitable number of consecutive days (for example, for seven days).

### 20. Points of Sampling

20.1 Refer to Section 11.

### 21. Conditioning Requirements

21.1 If flushing of the sample line/sampler between composite samples is practical, follow procedures outlined in 12.2. Otherwise, assure composite sampler design selects a representative sample at each sample interval.

21.2 *Temperature and Pressure Adjustment*—Refer to 12.3.

## 22. Sample Collection

22.1 Composite samples may be made by mutual agreement of the interested parties by combining individual (grab) samples taken at frequent intervals or by means of automatic samplers.

22.1.1 Consult individual test methods for the effect of time interval and temperature prior to analysis.

22.2 Indicate whether or not the volume of sample is proportional to the rate of flow. Composite samples which are not proportional to the process stream flow rate are not necessarily representative. At the end of a definite period, mix the composite sample thoroughly so that determinations on a portion of the composite sample may be determined by analysis of the individual samples.

## 23. Sample Handling

23.1 For information on sample handling, refer to the appropriate section of this practice as follows:

	Section
Sample Containers	7.9 to 7.12
Preservation of Samples	15
Time Interval Between Collection and Analysis of Samples	16
Labeling and Transportation of Samples	17

## PRACTICE C—CONTINUAL SAMPLING

### 24. Scope

24.1 This practice is applicable to sampling water from sources such as pipelines and conduits, processing tanks and vats, towers, filters, and steam generators on a continual basis for chemical, physical, or radiological analyses.

### 25. Frequency and Duration of Sampling

25.1 Sampling is essential on a continuous basis. Some analysis equipment may perform analyses on a batch basis but the sample shall flow continuously. Intermittent sample flow versus analyzer operation is possible through use of sample bypass equipment, although this is seldom used except in measuring variables with a time relationship, such as rate of oxygen uptake. In these cases, deviations from this practice shall be handled under descriptions of the specific measurement.

### 26. Points of Sampling

26.1 Selection of sampling points should conform to the applicable paragraphs in Section 11.

26.2 When simultaneous samples from several locations are required, water is drawn continuously from each individual

source proportionate to flow and mixed into a single sample. The flow rate from each sample stream should be controlled and regulated to ensure adequate flow.

### 27. Conditioning Requirements

27.1 Most on-line sensors require careful sample conditioning. Close control of final sample temperature using secondary cooling is recommended for analyses where accuracy variations that can be attributed to variable sample temperatures deviating from 77°F (25°C) cannot be tolerated. Practice D 5540 gives recommended methods for flow control and temperature control for on-line water sampling and analysis equipment.

27.2 If a continual sampling system is out of service or is used cyclically, flushing of the sample lines and components is necessary. Refer to 12.2.

### 28. Sample Collection

28.1 Manufacturers of continuous analyzers and samplers will generally specify temperature, flow continuity, volume, and pressure requirements for proper operation. Sample tubing/piping and conditioning apparatus should be in accordance with 7.1 to 7.3 and Practice D 5540.

### 29. Time Interval Between Collection and Analysis of Sample

29.1 In a continually operating system the time lag between the system intake and the point of sample delivery is a function of the flow rate of the water and the dimensions of the intervening pipe. Usually, the system dimensions make this time short so that the analysis results reflect the conditions in the process. Refer to 7.1. Wherever special precautions should be observed, they will be described in the particular method covering the analysis.

29.2 The time response of the system describes its ability to respond to transient conditions in the water source. Time response is defined as the time required for the system to reach 63.2 % of the total change between the state of initial equilibrium and final equilibrium in response to a step change introduced at the input to the system. Excessive delay in sample delivery may result in changes in process stream constituents not being detected in a timely manner.

### 30. Keywords

30.1 back pressure regulator; pressure reducer; sample cooler; sampling; sampling equipment; variable rod-in-tube orifice; water



**D 3370**

## REFERENCES

- (1) "Survey of Corrosion Product Generation, Transport, and Deposition in Light Water Reactors," Electric Power Research Institute Report NP-522, March 1979.
- (2) Eater, L., "Make Sure Water Chemistry Samples are Representative," *Power*, July 1989, pp. 47–50.
- (3) Davis, J., and Blair, C., "Guidelines for Design and Operation of Condensate and Feedwater Sampling Systems," *Ultrapure Water*, April 1989, pp. 18–27.
- (4) Coulter, E., "Sampling Steam and Water in Thermal Power Plants," Electric Utility Workshop, University of Illinois, March 1988.
- (5) *Guideline Manual on Instrumentation and Control for Fossil Plant Cycle Chemistry*, Electric Power Research Institute, April 1987, EPRI CS-5164.
- (6) *Steel Products Manual: Stainless and Heat Resisting Steels*, American Iron and Steel Institute, December 1974.
- (7) Maeda, K., et al, "Improvements of Metal Impurities, Sampling and Measurement," 1990 International Conference on Measuring Waterborne Trace Substances, Electric Power Research Institute and National Institute of Standards and Technology, Baltimore, MD, August 28–30, 1990.
- (8) Polley, M. V., and Brookes, I. R., "PWR Primary Coolant Sample Lines—Problems with Measurement of Corrosion Products and Experimental Proposals for Ringhals PWR," Central Electricity Generating Board, Gloucestershire, United Kingdom, TPRD/B/0940/R87, July 1987.
- (9) Dickinson, N. L., Keilbaugh, W. A., and Pocock, F. J., "Some Physico-Chemical Phenomenon in Supercritical Water," ASME Paper No. 58-A-267.
- (10) "Safe Handling of Radioactive Materials," NCRP Report No. 30, National Council on Radiation Protection and Measurements, Bethesda, Maryland, March 9, 1964.
- (11) "Standards for Protection Against Radiation," 10 CFR 20, U.S. Government Printing Office, Superintendent of Documents, Washington, DC 20402.
- (12) 49 CFR 171–177, Subchapter C, "Hazardous Materials Regulations," of Chapter 1, "Research and Special Programs Administration, Department of Transportation," of Title 49 of the Code of Federal Regulations, U.S. Government Printing Office, Superintendent of Documents, Washington, DC 20402.
- (13) Chen, Yu-Sen, Bloom, Deborah M., and Nimry, N., "Sampling and Analysis of Copper in Power Generation Systems," 1990 International Conference on Measuring Waterborne Trace Substances, op cit.
- (14) "Measuring, Evaluating, and Reporting Radioactivity in Solid Wastes and Releases of Radioactive Materials in Liquid and Gaseous Effluents from Light-Water-Cooled Nuclear Power Plants," United States Nuclear Regulatory Commission, Regulatory Guide 1.21, Revision 1 (June 1974), or latest revision.

*The American Society for Testing and Materials takes no position respecting the validity of any patent rights asserted in connection with any item mentioned in this standard. Users of this standard are expressly advised that determination of the validity of any such patent rights, and the risk of infringement of such rights, are entirely their own responsibility.*

*This standard is subject to revision at any time by the responsible technical committee and must be reviewed every five years and if not revised, either reapproved or withdrawn. Your comments are invited either for revision of this standard or for additional standards and should be addressed to ASTM Headquarters. Your comments will receive careful consideration at a meeting of the responsible technical committee, which you may attend. If you feel that your comments have not received a fair hearing you should make your views known to the ASTM Committee on Standards, at the address shown below.*

*This standard is copyrighted by ASTM, 100 Barr Harbor Drive, PO Box C700, West Conshohocken, PA 19428-2959, United States. Individual reprints (single or multiple copies) of this standard may be obtained by contacting ASTM at the above address or at 610-832-9585 (phone), 610-832-9555 (fax), or service@astm.org (e-mail); or through the ASTM website (www.astm.org).*