



Designation: D 4411 – 9803

Standard Guide for Sampling Fluvial Sediment in Motion¹

This standard is issued under the fixed designation D 4411; the number immediately following the designation indicates the year of original adoption or, in the case of revision, the year of last revision. A number in parentheses indicates the year of last reapproval. A superscript epsilon (ϵ) indicates an editorial change since the last revision or reapproval.

1. Scope*

1.1 This guide covers the equipment and basic procedures for sampling to determine discharge of sediment transported by moving liquids. Equipment and procedures were originally developed to sample mineral sediments transported by rivers but they are applicable to sampling a variety of sediments transported in open channels or closed conduits. Procedures do not apply to sediments transported by flotation.

1.2 This guide does not pertain directly to sampling to determine nondischarge-weighted concentrations, which in special instances are of interest. However, much of the descriptive information on sampler requirements and sediment transport phenomena is applicable in sampling for these concentrations, and 9.2.8 and 13.1.3 briefly specify suitable equipment. Additional information on this subject will be added in the future.

1.3 The cited references are not compiled as standards; however they do contain information that helps ensure standard design of equipment and procedures.

1.4 Information given in this guide on sampling to determine bedload discharge is solely descriptive because no specific sampling equipment or procedures are presently accepted as representative of the state-of-the-art. As this situation changes, details will be added to this guide.

1.5 *This standard does not purport to address all of the safety concerns, if any, associated with its use. It is the responsibility of the user of this standard to establish appropriate safety and health practices and determine the applicability of regulatory limitations prior to use.* Specific precautionary statements are given in Section 12.

2. Referenced Documents

2.1 ASTM Standards:

D 1129 Terminology Relating to Water²

¹ This guide is under the jurisdiction of ASTM Committee D-19 on Water and is the direct responsibility of Subcommittee D19.07 on Sediments, Geomorphology, and Open-Channel Flow.

Current edition approved Dec. 10, 1998; 2003. Published March 1999; September 2003. Originally published as D 4411 – 84; approved in 1984. Last previous edition approved in 1998 as D 4411 – 93 ϵ .

*A Summary of Changes section appears at the end of this standard.

3. Terminology

3.1 Definitions:

3.1.1 *isokinetic*—a condition of sampling, whereby liquid moves with no acceleration as it leaves the ambient flow and enters the sampler nozzle.

3.1.2 *sampling vertical*—an approximately vertical path from water surface to the streambed. Along this path, samples are taken to define various properties of the flow such as sediment concentration or particle-size distribution.

3.1.3 *sediment discharge*—mass of sediment transported per unit of time.

3.1.4 *suspended sediment*—sediment that is carried in suspension in the flow of a stream for appreciable lengths of time, being kept in this state by the upward components of flow turbulence or by Brownian motion.

3.1.5 For definitions of other terms used in this guide, see Terminology D 1129.

3.2 Definitions of Terms Specific to This Standard:

3.2.1 *concentration, sediment*—the ratio of the mass of dry sediment in a water-sediment mixture to the volume of the water-sediment mixture. Refer to Practice D 3977.

3.2.2 *depth-integrating suspended sediment sampler*—an instrument capable of collecting a water-sediment mixture isokinetically as the instrument is traversed across the flow; hence, a sampler suitable for performing depth integration.

3.2.3 *depth-integration*—a method of sampling at every point throughout a sampled depth whereby the water-sediment mixture is collected isokinetically to ensure the contribution from each point is proportional to the stream velocity at the point. This method yields a sample that is discharge-weighted over the sampled depth. Ordinarily, depth integration is performed by traversing either a depth- or point-integrating sampler vertically at an acceptably slow and constant rate; however, depth integration can also be accomplished with vertical slot samplers.

3.2.4 *point-integrating suspended-sediment sampler*—an instrument capable of collecting water-sediment mixtures isokinetically. The sampling action can be turned on and off while the sampler intake is submerged so as to permit sampling for a specified period of time; hence, an instrument suitable for performing point or depth integration.

3.2.5 *point-integration*—a method of sampling at a fixed point whereby a water-sediment mixture is withdrawn isokinetically for a specified period of time.

3.2.6 *stream discharge*—the quantity of flow passing a given cross section in a given time. The flow includes the mixture of liquid (usually water), dissolved solids, and sediment.

4. Significance and Use

4.1 This guide is general and is intended as a planning guide. To satisfactorily sample a specific site, an investigator must sometimes design new sampling equipment or modify existing equipment. Because of the dynamic nature of the transport process, the extent to which characteristics such as mass concentration and particle-size distribution are accurately represented in samples depends upon the method of collection. Sediment discharge is highly variable both in time and space so numerous samples properly collected with correctly designed equipment are necessary to provide data for discharge calculations. General properties of both temporal and spatial variations are discussed.

5. Design of the Sampling Program

5.1 The design of a sampling program requires an evaluation of several factors. The objectives of the program and the tolerable degree of measurement accuracy must be stated in concise terms. To achieve the objectives with minimum cost, care must be exercised in selecting the site, the sampling frequency, the spatial distribution of sampling, the sampling equipment, and the operating procedures.

5.2 A suitable site must meet requirements for both stream discharge measurements and sediment sampling (1).⁴ The accuracy of sediment discharge measurements are directly dependent on the accuracy of stream discharge measurements. Stream discharge usually is obtained from correlations between stream discharge, computed from flow velocity measurements, the stream cross-section geometry, and the water-surface elevation (stage). The correlation must span the entire range of discharges which, for a river, includes flood and low flows. Therefore, it is advantageous to select a site that affords a stable stage-discharge relationship. In small rivers and man-made channels, artificial controls as weirs can be installed. These will produce exceptionally stable and well defined stage-discharge relationships. In large rivers, only natural controls ordinarily exist. Riffles and points where the bottom slope changes abruptly, such as immediately upstream from a natural fall, serve as excellent controls. A straight uniform reach is satisfactory, but the reach must be removed from bridge piers and other obstructions that create backwater effects.

5.3 A sampling site should not be located immediately downstream from a confluence because poor lateral mixing of the sediment will require an excessive number of samples. Gaging and sampling stations should not be located at sites where there

² Annual Book of ASTM Standards, Vol 11.01.

³ Discontinued; see 1994 Annual Book of ASTM Standards, Vol 11.02.

⁴ The boldface numbers in parentheses refer to the list of references at the end of this standard.

is inflow or outflow. In rivers, sampling during floods is essential so access to the site must be considered. Periods of high discharge may occur at night and during inclement weather when visibility is poor. In many instances, bridges afford the only practical sampling site.

5.4 Sampling frequency can be optimized after a review of the data collected during an initial period of intensive sampling. Continuous records of water discharge and gage height (stage) should be maintained in an effort to discover parameters that correlate with sediment discharge, and, therefore, can be used to indirectly estimate sediment discharge. During periods of low-water discharge in rivers, the sampling frequency can usually be decreased without loss of essential data. If the sediment discharge originates with a periodic activity, such as manufacturing, then periodic sampling may be very efficient.

5.5 The location and number of sampling verticals required at a sampling site is dependent primarily upon the degree of mixing in the cross section. If mixing is nearly complete, that is the sediment is evenly and uniformly distributed in the cross section, a single sample collected at one vertical and the water discharge at the time of sampling will provide the necessary data to compute instantaneous sediment-discharge. Complete mixing rarely occurs and only if all sediment particles in motion have low fall velocities. Initially, poor mixing should be assumed and, as with sampling any heterogeneous population, the number of sampling verticals should be large.

5.6 If used properly, the equipment and procedures described in the following sections will ensure samples with a high degree of accuracy. The procedures are laborious but many samples should be collected initially. If acceptably stable coefficients can be demonstrated for all anticipated flow conditions, then a simplified sampling method, such as pumping, may be adopted for some or all subsequent sampling.

6. Hydraulic Factors

6.1 Modes of Sediment Movement :

6.1.1 Sediment particles are subject to several forces that determine their mode of movement. In most instances where sediment is transported, flow is turbulent so each sediment particle is acted upon by both steady and fluctuating forces. The steady force of gravity and the downward component of turbulent currents accelerate a particle toward the bed. The force of buoyancy and the upward components of turbulent currents accelerate a particle toward the surface. Relative motion between the liquid and the particle is opposed by a drag force related to the fluid properties and the shape and size of the particle.

6.1.2 Electrical charges on the surface of particles create forces that may cause the particles to either disperse or flocculate. For particles in the submicron range, electrical forces may dominate over the forces of gravity and buoyancy.

6.1.3 Transport mode is determined by the character of a particle's movement. Clay and silt-size particles are relatively unaffected by gravity and buoyant forces; hence, once the particles are entrained, they remain suspended within the body of the flow for long periods of time and are transported in the suspended mode.

6.1.4 Somewhat larger particles are affected more by gravity. They travel in suspension but their excursions into the flow are less protracted and they readily return to the bed where they become a part of the bed material until they are resuspended.

6.1.5 Still larger particles remain in almost continuous contact with the bed. These particles, termed bedload, travel in a series of alternating steps interrupted by periods of no motion when the particles are part of the streambed. The movement of bedload particles invariably deforms the bed and produces a bed form (that is, ripples, dunes, plane bed, antidunes, etc.), that in turn affects the flow and the bedload movement. A bedload particle moves when lift and drag forces or impact of another moving particle overcomes resisting forces and dislodges the particle from its resting place. The magnitudes of the forces vary according to the fluid properties, the mean motion and the turbulence of the flow, the physical character of the particle, and the degree of exposure of the particle. The degree of exposure depends largely on the size and shape of the particle relative to other particles in the bed-material mixture and on the position of the particle relative to the bed form and other relief features on the bed. Because of these factors, even in steady flow, the bedload discharge at a point fluctuates significantly with time. Also, the discharge varies substantially from one point to another.

6.1.6 Within a river or channel, the sizes of the particles in transport span a wide range and the flow condition determines the mode by which individual particles travel. A change in flow conditions may cause particles to shift from one mode to the other.

6.1.7 For transport purposes, the size of a particle is best characterized by its fall diameter because this describes the particle's response to the steady forces in the transport process.

6.2 Dispersion of Suspended Sediment :

6.2.1 The various forces acting on suspended-sediment particles cause them to disperse vertically in the flow. A particle's upward velocity is essentially equal to the *difference* between the mean velocity of the upward currents and the particle's fall velocity. A particle's downward velocity is essentially equal to the *sum* of the mean velocity of the downward currents and the particle's fall velocity. As a result, there is a tendency for the flux of sediment through any horizontal plane to be greater in the downward direction. However, this tendency is naturally counteracted by the establishment of a vertical concentration gradient. Because of the gradient, the sediment concentration in a parcel of water-sediment mixture moving upward through the plane is higher than the sediment concentration in a parcel moving downward through the plane. This difference in concentration produces a net upward flux that balances the net downward flux caused by settling. Because of their high fall velocities, large particles have a steeper gradient than smaller particles. Fig. 1 (2) shows (for a particular flow condition) the gradients for several particle-size ranges. Usually, the concentration of particles smaller than approximately 60 μm will be uniform throughout the entire depth.

6.2.2 Turbulent flow disperses particles laterally from one bank to the other. Within a long straight channel of uniform cross

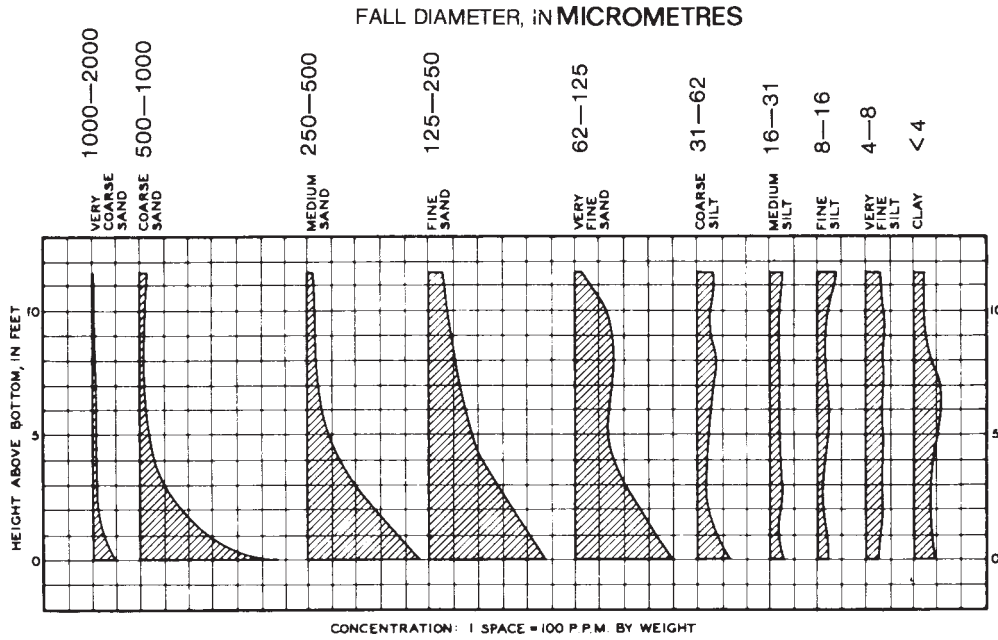

FIG. 1 (2) Vertical Distribution of Sediment in the Missouri River at Kansas City, MO

section, lateral concentration gradients will be nearly symmetrical and vertical concentration gradients will be similar across the section. However, within a channel of irregular cross section, lateral gradients will lack symmetry and vertical gradients may differ significantly. Fig. 2 (3) illustrates the variability within one cross section of the Rio Grande.

6.2.3 Sediment entering from the side of a channel slowly disperses as it moves downstream and lateral gradients may exist for several hundred channel widths downstream. In or near a channel bend, secondary flow accentuates both horizontal and vertical gradients. Until data have been collected to prove the contrary, one must assume both gradients exist and design sampling procedures accordingly.

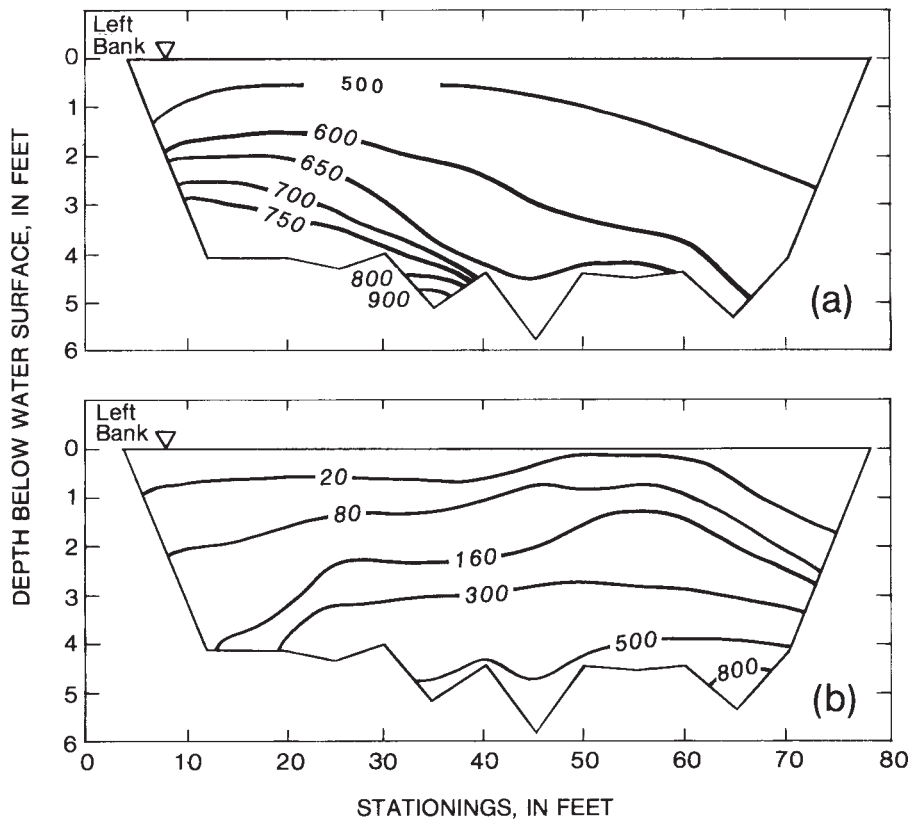

FIG. 2 (3) Cross-Sectional Variability of Suspended Material in Two Different Size Ranges, Rio Grande, near Bernardo, NM (a) Contours in mg/L for Material Between 0.0625 and 0.125 mm; (b) Contours in mg/L for Material Between 0.25 and 0.5 mm

6.2.4 At sections where spatial variability exists, samples must be collected from many regions within a cross section. Only for special conditions will samples from one or two points be adequate.

6.2.5 Despite turbulent currents that disperse particles along the direction of flow, the concentration at a fixed point will vary with time even if flow conditions are steady. Temporal variability depends upon many factors. Within a group of samples collected during a short period of time, the concentration of any sample generally will not deviate from the mean by more than approximately 20 %; however, every sample must be composed of a stream filament at least 50 ft long.

7. Spatial and Temporal Variations in Bedload Discharge

7.1 Bedload discharges vary both within a section and along the channel due to variations in the sediment and mean flow properties, turbulence, patterns of secondary circulation and position relative to the bed relief. (See 13.1, also 7.2.) Also, because of the intimate relationship between bedload discharge and the flow forces, particles that move as bedload at one section may be immobile or may move as suspended load at another cross section. As a result, the proportion of bedload discharge to total sediment transport may vary longitudinally and bedload discharge observed at one section may not be representative of the bedload discharge at another section.

7.2 Although data on the temporal variation in bedload discharge are far from abundant, observations with bedload samplers have shown that discharges vary dramatically and tend to be cyclic. In one study (4) of a river having bed material of coarse cobbles, bedload samples collected every 3 min during a 3-h test showed a coefficient of variation of 41 % and an oscillation period of about seven minutes. Another study (5), conducted in a laboratory flume with a bed of coarse gravel, showed that the coefficient of variation of bedload samples collected every minute during a 1-h test was 100 %. Temporal variations at a fixed sampling point are caused, in large measure, by the passage of bed forms. Because a single measurement at a point probably will not be representative of the mean bedload discharge, numerous repetitive measurements must be made at each measurement point during a time interval that is sufficiently long to allow a number of bed-form wave-lengths to pass. Alternatively, the sampling position must be moved longitudinally so that samples are obtained randomly over parts of several bed-form wave-lengths.

8. Spatial and Temporal Variations in Total-Sediment Discharge

8.1 Temporal and spatial variations in the total sediment discharge result from the combined effects of variations in the suspended-sediment discharge and the bedload discharge. Detailed information on the extent of temporal variations in total load are scarce; however, as with variations in suspended sediment discharge, the variations in total load can be expected to change according to particle size. Ordinarily, at normal river sections, the total load cannot be measured as a separate entity; therefore, it is obtained by combining observations of the suspended load and the bedload. When the total-sediment discharge is determined from measurements of the suspended-sediment and bedload discharges, sufficient sampling must be performed to account for the temporal and spatial variations in both quantities.

8.1.1 At certain kinds of unusual sections, such as outfalls, sills and weirs, or in highly turbulent flow, all of the sediment particles may be entrained in the water; consequently, total load can be measured by sampling through the nappe or through the entire depth. Such sections are often called total-load sections. At total-load sections, spatial variations in the total sediment discharge can be significant and are functions of the lateral variations in flow properties, suspended-sediment concentration, and bedload discharge. At total-load sections, sampling must be carried out in accordance with the principles of suspended-sediment sampling and replicate samples must be collected at a sufficient number of lateral locations to account for variations in the discharge of entrained bedload particles.

9. Selection and Design of Sampling Apparatus

9.1 Apparatus selection depends upon the object of the sampling program and the physical and hydraulic characteristics of the site. To sample for total sediment discharge within a straight section of open channel, use a suspended-sediment sampler in conjunction with a bedload sampler. If initial measurements show that nearly all of the total load is transported in suspension, routine sampling can be simplified by eliminating bedload measurements. At an outfall, total load may be measured by sampling through the nappe with a depth-integrating sampler. Because these samplers are calibrated when fully submerged, the depth of the nappe should be great enough to ensure the flow contacts the region downstream of the air exhaust port. For continuous sampling of total load, a traveling-slot or a stationary-slot sampler may be used.

9.2 Suspended Sediment Samplers :

9.2.1 Whenever the fluid within a streamtube accelerates by changing either its direction or speed, sediment particles tend to migrate across the streamtube boundaries. This migration causes a local enrichment or depletion in the sediment concentration. To avoid such changes at a sampling nozzle, suspended-sediment samplers must operate isokinetically (or nearly isokinetically). If the velocity at the entrance of the sampler nozzle deviates from ambient velocity by less than $\pm 15\%$, the error in concentration will seldom exceed $\pm 5\%$. The angle between the axis of the nozzle and the approaching flow should not exceed 20° .

9.2.2 Two basic types of isokinetic instruments are commonly used to sample suspended sediment. One type (integrating) accumulates the liquid-sediment mixture by withdrawing it during a long period of time. The other type (trap) instantaneously traps a volume of the mixture by simultaneously closing off the ends of a flow-through chamber. The integrating type collects a long filament of flow, hence, the sample concentration is only slightly affected by short-term fluctuations in the concentration within the approaching flow. For this reason, integrating types are recommended over trap types.

9.2.3 For integrating-type samplers it is recommended that the nozzle entrance be circular in cross section and have an inside diameter of 3.2 mm (1/8 in.) or larger. A nozzle with a diameter of 4.8 mm or 6.3 mm (3/16 in. or 1/4 in.) is preferred, or larger. At the nozzle entrance, the wall thickness should not exceed 1.6 mm (1/16 in.) and the outside edge should be gently rounded.

9.2.4 To ensure an undisturbed flow pattern, the nozzle must extend upstream from its support which may be a tethered body or a fixed support strut. An upstream distance of 25.4 mm (1 in.) is adequate provided the support is well streamlined and its largest dimension lateral to the flow is not more than 40 nozzle diameters.

9.2.5 After entering the nozzle, the sample must be conveyed, without a change in concentration, to a container. If the volume of the conduit is more than approximately 5 % of the sample volume, the velocity within the conduit must be adequate to ensure transport as a homogeneous suspension. A velocity exceeding $17W$ is recommended where W equals settling velocity of the largest particle in suspension.

9.2.6 Integrating samplers that meet the above requirements are fabricated commercially in the United States. The samplers, which are listed in Table 1 (6), belong to the “US series” designed and sold by the Federal Interagency Sedimentation Project. The samplers are of two types, depth-integrating and point-integrating.

9.2.7 *Depth-Integrating Samplers* —US series depth-integrating samplers have an intake nozzle and exhaust port but they do not have a valve; therefore, they sample the water-sediment mixture continuously when submerged. They are highly reliable because they do not contain moving parts; furthermore, they are suitable for use in a sampling technique termed “depth integration” (see 13.1.4). Depth-integrating samplers have a maximum operating depth (see Table 1) (6). Fig. 3 (7) shows the shape of one member of the US series of depth-integrators. Auxiliary equipment includes a cable-and-reel suspension system, or for the DH-48 (8) and DH-75, DH-81, a wading-rod suspension. During the depth-integration process, a sampler must be lowered and raised at a uniform rate so cable-speed indicators or timing devices are used whenever possible.

9.2.8 *Point-Integrating Samplers* —US series point-integrating samplers have an intake nozzle and exhaust port that can be opened and closed while the samplers are submerged. They also contain a pressure-equalization system to ensure that the pressure within the sample container equals the hydrostatic pressure whenever the intake-exhaust valve is opened. These features allow the samplers to be used for sampling by either the depth integration or point integration (see 13.1.3) techniques. Maximum allowable depths listed for these samplers in Table 1 (6) apply when they are used for point integration. When the samplers are used for depth integration starting at the water surface, the depth limitations given in footnote B of Table 1 (6) specify the length of the allowable two-way vertical sampling path for any single-sample container; segments of an allowable path length can be sampled throughout all or any part of the maximum allowable depth by using multiple containers and opening and closing the intake-exhaust valve appropriately. If sampling is done by one-way integration, the allowable path length is twice the listed value. In addition to a suspension and speed indicating system, the samplers also require a source of electrical power.

10. Bedload Samplers

10.1 Both in Europe and the United States many different kinds of bedload monitoring apparatus (9) have been developed to measure the transport of a wide variety of bed-material particles that occur in nature. In general, each kind of apparatus was designed to monitor a particular range of bedload sizes and transport rates. Two broad classifications exist, direct-measuring apparatus and indirect-measuring apparatus. Direct-measuring apparatus collect and accumulate bedload particles for a given period of time. Indirect-measuring apparatus monitor some property of the bedload or some phenomena that occurs as a result of bedload movement. In addition, bedload discharge can be determined from measurements of the rate of (1) migration of bedforms, (2) movement of tracer particles, (3) deposition or erosion in a given area, and (4) change with distance in the concentration of some nonconservative property associated with the bedload particles. This nonconservative property, such as radioactivity, must have a known time rate of decay.

10.1.1 No portable direct-measuring apparatus nor indirect technique is generally accepted at this time as being entirely suitable for determining bedload discharge.

10.2 Direct Measuring Apparatus :

Direct-measuring apparatus can be classified into four general categories; box or basket samplers, pan or tray samplers, pressure-difference samplers, and slot or pit samplers.

10.2.1 *Box or Basket Samplers*—Enclosures are open at the upstream end and possibly at the top, and have either solid sides, mesh sides, or a combination of both. Particles are retained within the sampler either by being screened from the flow or by settling in regions of reduced flow velocities within the sampler.

10.2.2 *Pan or Tray Samplers*—These samplers collect particles that drop into one or more sections or slots after the particles have been transported up an entrance ramp.

10.2.3 *Pressure-Difference Samplers* —Essentially box or basket samplers that have entrances or other features that create a pressure drop that overcomes the flow resistance within the sampler and thereby keeps flow velocities at the entrance about the same as the stream velocity.

10.2.4 *Slot or Pit Samplers*—These samplers consist of collection chambers that accumulate particles as they drop over the forward edge of a chamber that is buried in the stream bed.

10.3 Indirect-Measuring Apparatus :

Most indirect-measuring apparatus are acoustical devices that measure (1) the magnitude and frequency of particle-sampler or particle-particle collisions or (2) the attenuation of energy. Apparatus of this type ordinarily give only qualitative information and

TABLE 1 (6) Physical Characteristics of US-Series Depth-Integrating and Point-Integrating Samplers for Collecting Samples of Water-Suspended Sediment Mixtures (after Table 3-3, National Handbook of Recommended Methods for Water-Data Acquisition)

NOTE 1—[Type: DI, depth-integrating; PI, point-integrating. Available nozzle size: A, 6.4 mm; B, 4.8 mm; C, 3.2 mm; D, 7.9 mm. Body material: AL, aluminum; BR, bronze; PS, plated steel].

Name	Type of Sampler	Method of Suspension	Mass, kg	Overall Length, m	Available Nozzle Size	Sample Container Size, mL	Maximum Allowable Depth, m	Maximum Calibrated Velocity, m/s	Distance Between Nozzle and Sampler Bottom, mm	Body Material	Remarks
US DH-48	DI	rod	-2.0	0.33	A, B ^A	473	B	2.7	90	AL	for wading.
US DH-48	DI	rod	2.0	0.33	A ^A , B	473	B	2.7	90	AL	for wading.
US DH-59	DI	cable	-10.2	0.42	A, B, C	473	B	1.5	114	BR	for hand-line operation.
US DH-59	DI	cable	10.2	0.42	A, B	473	B	1.5	114	BR	for hand-line operation.
US DH-75P	DI	rod	-0.4	0.26	B	500	B	2.0	83	PS	for sampling only in sub-freezing temperatures.
US DH-76	DI	cable	0.4	0.47	A, B	500	B	2.0	83	BR	for hand-line operation.
US D-74	DI	cable	28.2	0.66	A, B	473 or 946	B	2.0	103	BR	
US DH-75Q	DI	rod	-0.4	0.29	B	1000	B	2.0	111	PS	similar to US-DH-75P.
US D-74AL	DI	cable	0.4	0.66	A, B	473 or 946	B	1.8	111	C	light weight US D-74.
US DH-76	DI	rod	0.8	0.3	A, B, C	1000	4.6	2.1	102	PL, FL	for wading
US DH-81	DI	rod	0.8	0.3	A, B, C	1000	4.6	2.1	102	PL, FL	for wading
US DH-95	DI	cable	-10.9	0.47	A, B, C	946	B	2.0	80	BR	similar to US-DH-59.
US DH-95	DI	cable	13.1	0.61	A, B, C	1000	4.6	2.3	122	BR	for hand-line operation.
US D-74	DI	cable	-28.2	0.66	A, B, C	473 or 946	B	2.0	103	BR	similar to US-D-49.
US D-95	DI	cable	29.0	0.66	A, B, C	1000	4.6	2.0	122	BR	
US D-74AL	DI	cable	-11.4	0.66	A, B, C	473 or 946	B	1.8	111	G	similar to US-D-74.
US D-96	DI	cable	59.9	0.89	A, B, C	3000	C	3.8	102	BR/AL	Collapsible-bag sampler
US D-77	DI	cable	-34.0	0.75	A, B, C, D	3000	4.72	2.4	177	BR/AL	Collapsible-bag sampler
US D-96-A1	DI	cable	36.3	0.89	A, B, C	3000	C	1.8	102	BR/AL	Collapsible-bag sampler
US D-99	DI	cable	124.7	1.00	A, B, C	6000	D	4.6	241	BR	Collapsible-bag sampler
US D-99	DI	cable	124.7	1.00	A, B, C	6000	D	4.6	241	BR	Collapsible-bag sampler
US P-50	PI	cable	135.6	1.12	A	473 or 946	61.0 ^E	3.0	140	BR	
US P-50	PI	cable	135.6	1.12	A	473 or 946	41.0 ^F	3.0	140	BR	
US P-61-A1	PI	cable	47.5	0.71	A	473 or 946	61.0 ^E	2.0	109	BR	
US P-61-A1	PI	cable	47.5	0.71	A	473 or 946	41.0 ^F	2.0	109	BR	
US P-61-A1	PI	cable	47.5	0.71	A	473 or 946	54.9 ^E	2.0	109	BR	
US P-61-A1	PI	cable	47.5	0.71	A	473 or 946	36.6 ^F	2.0	109	BR	
US P-63	PI	cable	90.4	0.85	A	473 or 946	54.9 ^E	2.0	150	BR	
US P-63	PI	cable	90.4	0.85	A	473 or 946	36.6 ^F	2.0	150	BR	
US P-63	PI	cable	90.4	0.85	A	473 or 946	54.9 ^E	2.0	150	BR	
US P-63	PI	cable	90.4	0.85	A	473 or 946	36.6 ^F	2.0	150	BR	
US P-72	PI	cable	17.7	0.71	A	473 or 946	22.0 ^E	1.6	109	AL	
US P-72	PI	cable	17.7	0.71	A	473 or 946	15.5 ^F	1.6	109	AL	

^A 4.8-mm nozzle available by special order.

^B Varies with nozzle and container sizes as follows:

Nozzle Size	Container Size
A	473 mL
B	946 mL
C	54.89 m
D	4.9 m
E	4.9 m
F	2.7 m
G	4.9 m

^C Varies with nozzle and container sizes as follows:

Nozzle Size	Container Size
A	33.5 m
B	18.3 m
C	11.9 m

^D Varies with nozzle and container sizes as follows:

Nozzle Size	Container Size
A	23.8 m
B	36.6 m
C	67.1 m

^E With 473-mL container.

^F With 946-mL container.

their outputs must be correlated with known discharges to provide quantitative results. Acoustic devices are seldom used in routine data collection programs.

11. Total-Sediment Discharge Samplers

11.1 Because the total sediment discharge is composed of suspended-sediment particles, which moves along within the body of the flow essentially at stream velocity, and bedload particles, which moves in an interrupted fashion essentially in continuous

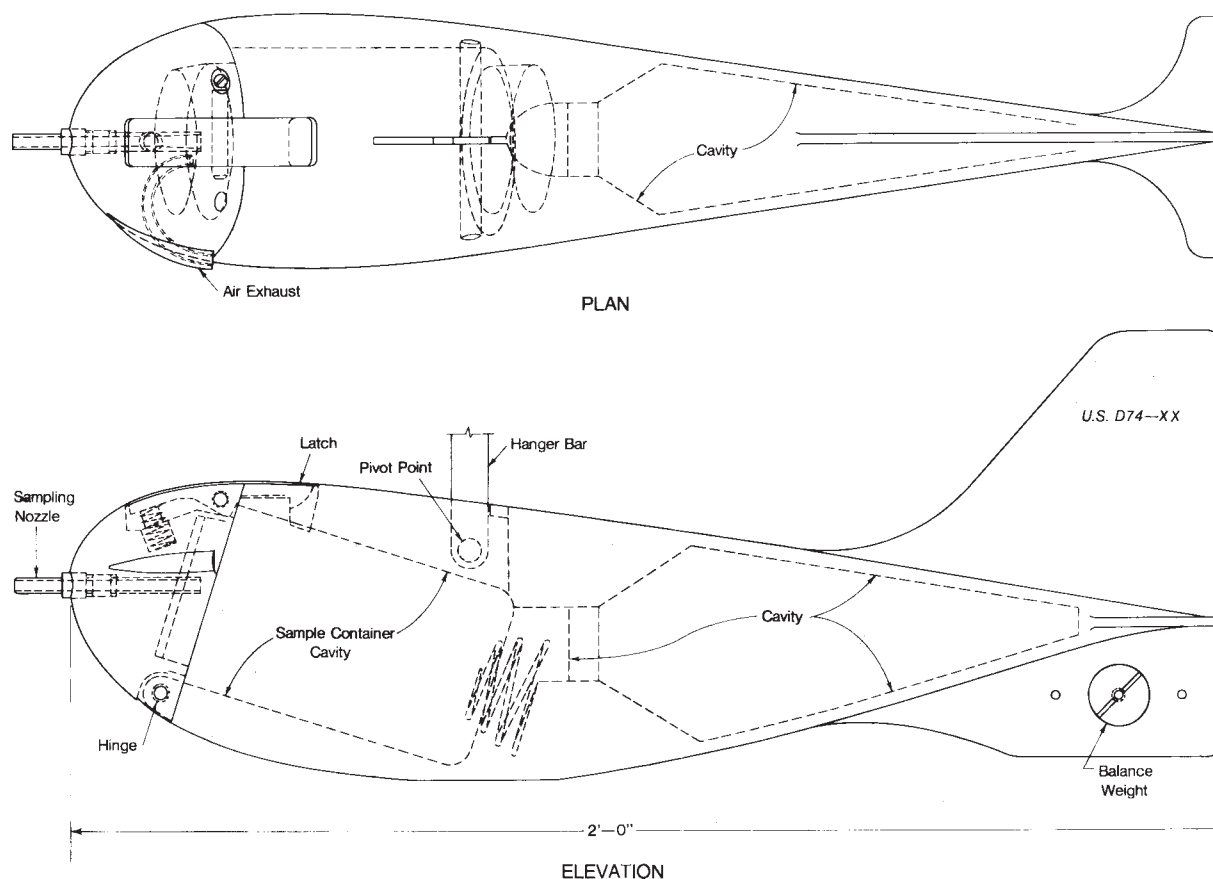

FIG. 3 (7) US D-74 Suspended Sediment Sampler

contact with the bed, no practical sampler has been designed for sampling total-sediment discharge at regular river sections. Normally, the total sediment discharge is determined from separate measurements of the suspended sediment discharge and the bedload discharge. Conventional sampling equipment can be used to measure the total sediment discharge at certain sections termed total-load sections. At an outfall, a sill, a weir, or a section where flow turbulence is sufficient to entrain all the sediment within the flow, suspended-sediment sampling equipment and techniques can be used to determine the discharge of particles finer than 2 mm. For particles coarser than 2 mm, use equipment that is capable of collecting and retaining coarse particles, and that is based on the isokinetic principles of suspended-sediment sampling. Such equipment includes slot samplers. Economic considerations usually preclude the construction of artificial total-load sections except on small streams. The ASCE Manual (10) illustrates a large but expensive turbulence flume.

11.2 If sampling can be conducted at a free outfall, slot samplers can be installed. By means of a slotted conduit positioned in the outfall, the slot sampler diverts a fraction of the water-sediment mixture into a suitable container. Slot samplers have been used extensively in erosion research and in laboratory flumes but standard designs have not been perfected for sampling sediment or industrial waste water in open channels or streams. Slot samplers are normally used in conjunction with a flume, weir, or other flow measuring devices.

11.3 The slot width must be adequate to permit free passage of the largest sediment particle; the conduit must be streamlined to minimize disturbance to the flow. Sides of the slot may be formed from rigid-metal sheets that are supported so that the slot opening faces the flow. The slot edges should be knife sharp and true to line. A tube or flexible pipe connected to the bottom of the slot carries the sample to a suitable storage container. The sampler is mounted on the downstream end of a flow measuring device with a free overfall. The height of the sampler slot must exceed the depth of flow. Some slot samplers will not function properly if the flow transports debris capable of clogging the slot. The slot may be located at a fixed point in the flow or it may be propelled across the flow. Accordingly, slot samplers may be divided into two broad categories, stationary or transversing.

11.4 *Stationary Slot Samplers*—Stationary slot samplers are simple to build and operate. They require no external source of power. To enhance self-clearing of debris, incline the slot at a slight downward angle. Fig. 4 (11) illustrates several types that have been tested. Samples are extracted along one fixed line so they are less representative than those collected with a traversing slot.

11.5 *Traversing Slots*—Traversing slots collect a sample representative of the entire cross section. The vertical slot sampler requires electric power, and is relatively insensitive to approach conditions. In situations where only infrequent clogging is anticipated, satisfactory performance may be obtained by using brushes or other equipment to periodically clean the slot. Fiber brushes mounted so that the slot is brushed before each pass through the flow nappe will usually assure satisfactory performance.

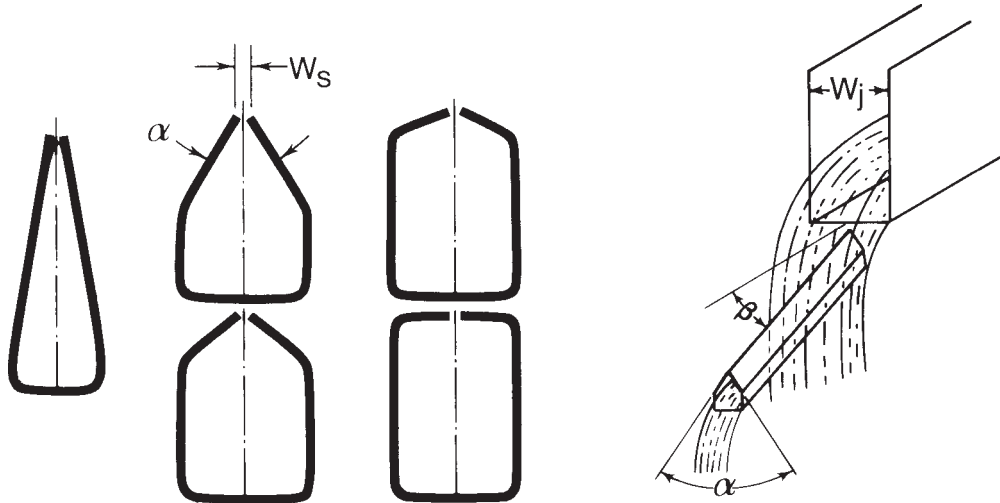

FIG. 4 (11) Cross Sections and Installation of Slot-Type Sampler

Fig. 5 (12) illustrates one type which has been tested.

11.6 *Rotating (Coshocton-Type) Sampler* —The rotating (Coshocton-type) sampler, (13) which is in the traversing category, consists of an elevated slot affixed to a revolving water wheel that is mounted on the downstream end of a small H-flume. Discharge from the flume falls on the water wheel and causes it to rotate. With each revolution the sampling slot cuts across the flow jet and extracts a sample. The sample falls into a collecting pan beneath the wheel and is routed through a closed conduit to a storage tank. A typical Coshocton-type sampler is pictured in Fig. 6 (13) and Fig. 7 (13). Sampler size, maximum discharge rate, sampling ratio, and other pertinent data are given in Table 2 (14).

11.6.1 The Coshocton sampler requires no external power source, however it is sensitive to upstream approach conditions. Rotation of the wheel may become erratic at stream discharges that exceed 80 % of the flume capacity.

12. Hazards

12.1 *Personal Clothing, Equipment, and Training: Precautions—Operators*—Operators should wear protective footgear and protective headgear, safety glasses, and leather gloves in addition to high-visibility clothing that is warm enough to prevent hypothermia and a Coast Guard approved personal flotation device. Where drowning is a hazard, perform sampling by teams that are equipped with wearing Coast Guard-approved personal-flotation devices and that are proficient in both swimming and first aid.

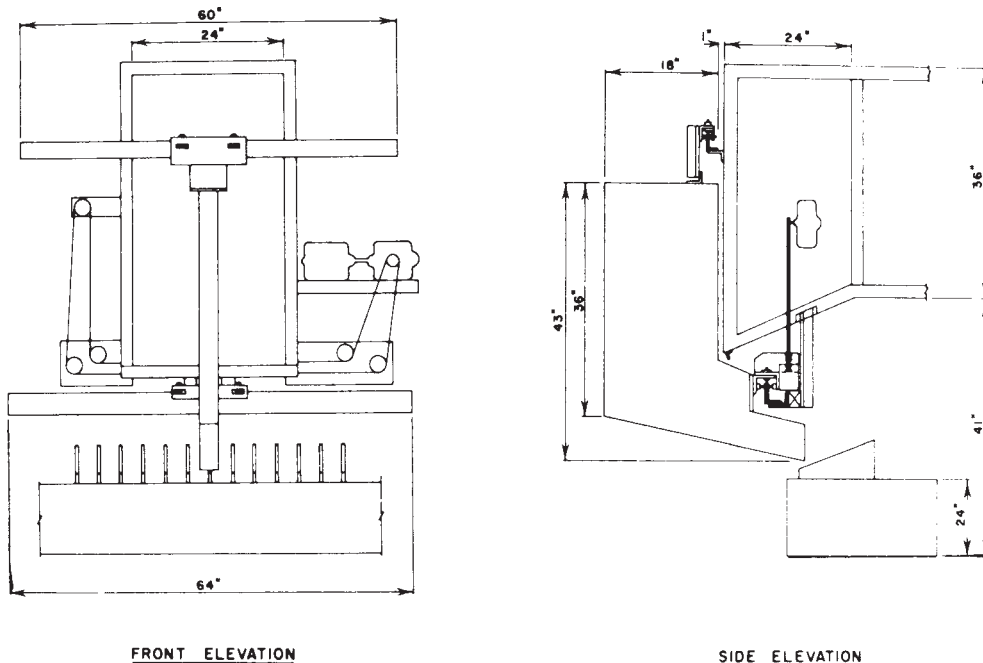

FRONT ELEVATION

SIDE ELEVATION

NOTE 1—1 in. = 25.4 mm. 12

FIG. 5 (12) Space Required for the Traversing-Slot Sampler Mounted on a 2-ft Parshall Flume

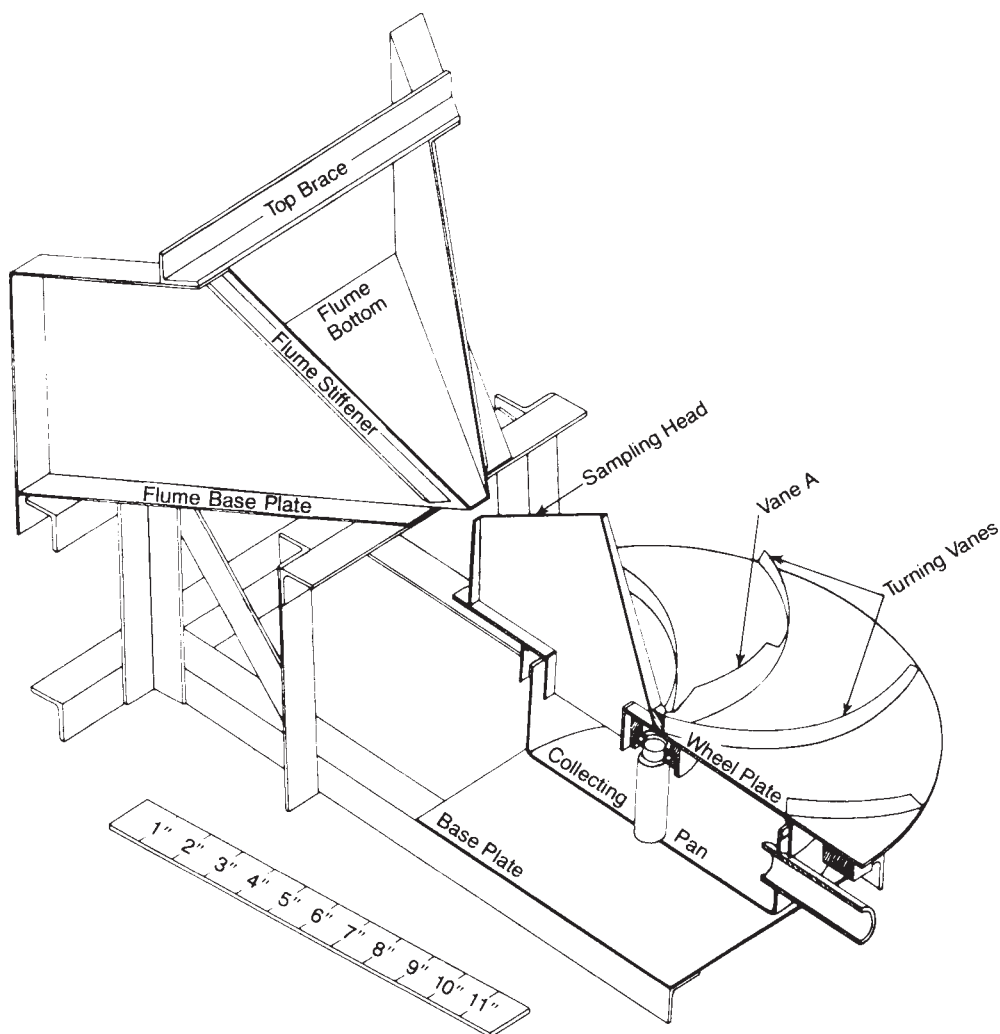

FIG. 6 (13) The N-1 Coshocton-Type Runoff Sampler

12.2 *Electrical Hazard:* ~~Warning~~—Equipment powered from low-voltage batteries is safer than equipment powered from 120-V, a-c distribution circuits. Regardless of the power source, ground the frames of hoists and other equipment to nearby metal objects such as bridge railings, bridge decks, or boat hulls. Use ground-fault detectors where applicable. During electrical storms, operators should retreat to low ground or take cover in a building or metal-topped vehicle.)

12.3 *Vehicles:* **Precautions**—Equip vehicles that must be parked on road shoulders with warning lights and flares in compliance with local regulations. Isolate the cargo area from the driver-passenger area; lash the cargo to prevent tipping or sliding.

12.4 *Sampling Wadable or Ice-Covered Streams:* **Precautions**—~~At~~—At crossings that appear marginal from safety aspects, test the surface with a rod or ice chisel, and wear a safety line anchored to a firm object on the shore. Wear a Coast Guard approved personal flotation device.

12.5 *Sampling from Overhead Cableways and Bridges:* **Precautions**—~~Inspect~~—Inspect supports and safety railings regularly for loose, worn, or weak components. At sites where trees or other heavy debris may snag a submerged sampler, the operator should be prepared to sever the suspension cable if the sample cannot be retrieved. Wear a Coast Guard approved personal flotation device.

12.6 *Reports and Medical Treatment* —Report all accidents and potentially dangerous situations promptly to the local safety officer. To save valuable time when an accident occurs, procedures for obtaining professional emergency treatment should be clearly understood by all operators.

13. Sampling Techniques

13.1 *Techniques for Sampling Suspended Sediment:*

13.1.1 Because of spatial variations in suspended sediment concentrations and in flow velocity, the discharge of suspended sediment through an area at any given instant is defined by Eq 1 (15) as follows:

$$G_{ss} = \int_A C U dA \quad (1)$$

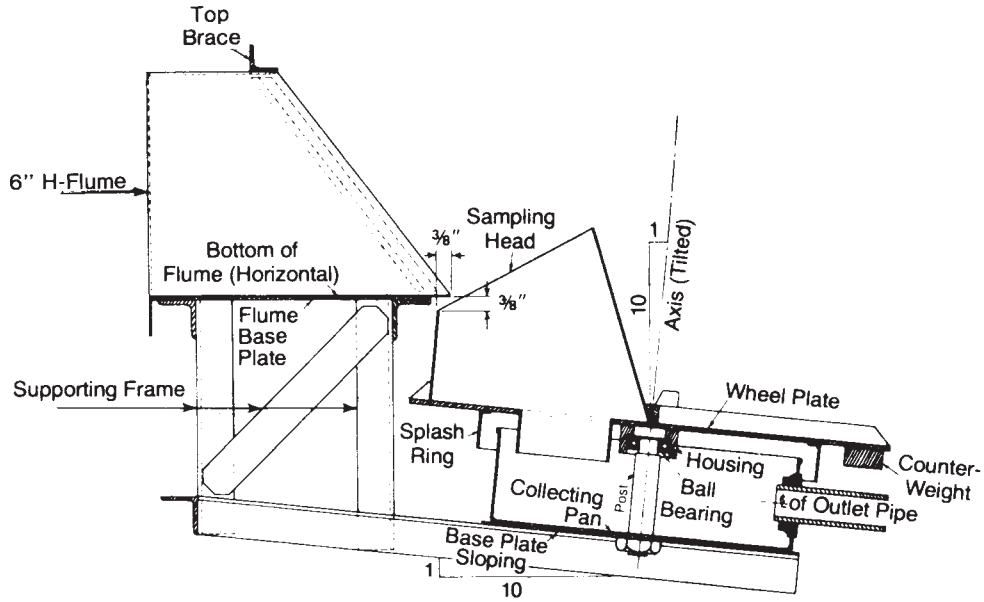

SECTION X-X
Scale 6" = 1' 0"

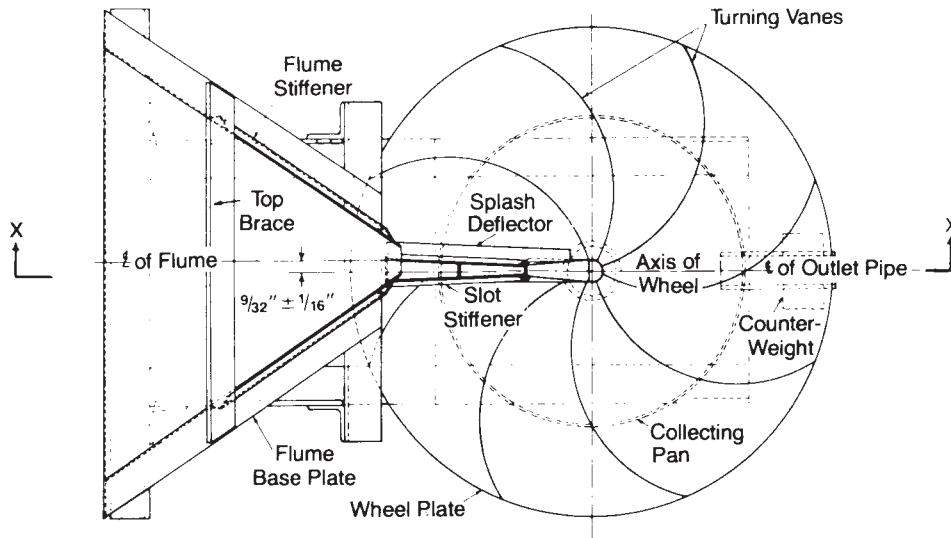

TOP VIEW
Scale 6" = 1'-0"

NOTE 1—1 in. = 25.4 mm, 1 ft = 0.3 m.

FIG. 7 (13) Details of the N-1 Coshocton-Type Runoff Sampler

TABLE 2 (14) Size Schedule for Coshocton Samplers

Sampler No.	Wheel Diameter	Capacity	Headroom Requirement	Aliquot	Approximate Weight
	Ft	Ft ³ /s	Ft	Pct	Lb
N-1	1	1/3	1 1/2	1	26
N-2	2	2	2 1/2	1/2	85
N-3	3	5 1/2	3 3/4	1/3	270

where:

$G_{s,s}$ = "instantaneous" suspended sediment discharge through a section of area A,

U = velocity of sediment particles through an elemental area d A,

C = suspended sediment concentration in the elemental spatial volume $U t' d A$,

for which:

t' = unit of the time used to express U .

In the practical application of Eq 1, U is considered to equal the flow velocity and C is considered to be constant during any given sampling period.

13.1.2 Three different techniques are commonly used to evaluate Eq 1; point integration, depth integration, and area integration. In point integration, samplers and sampling procedures are designed to yield spatial concentrations at a series of points throughout an area. These concentrations together with flow velocities from individual points are used to define concentration and velocity gradients, which, in turn are integrated according to Eq 1 to give the instantaneous suspended-sediment discharge through the area.

13.1.3 To sample by point integration, divide the flow area laterally into increments and collect samples at several depths along a vertical in each increment. Select increment widths and sampling depths so that between adjacent sampling points the difference in concentration and difference in velocity are small enough to conform with desired accuracy. Use a P-61-A1 or any other sampler that meets requirements of Section 9.

13.1.4 In depth integration and area integration, the sampling equipment and procedures are designed to mechanically and hydraulically perform the integration over the flow area. With both depth integration and area integration, an isokinetic sampler is traversed through the flow so that each incremental volume of mixture collected from the corresponding element of traversed area is in the same proportion to the sample volume as the stream discharge in each corresponding element is to the stream discharge in the sampled area. This procedure yields samples having “discharge-weighted” concentrations that can be multiplied directly with the stream discharge through the sampled area to yield the instantaneous suspended-sediment discharge through the area. The following derivation, which uses Eq 1 in discrete form, mathematically explains the concept. Consider a sampled area divided into N elemental areas of size $\Delta x \Delta y$. Let Q_i be the water discharge and C_i be the suspended-sediment concentration of mixture flowing through the i th element. The suspended-sediment discharge, G_{ss} , through the sampled area then is defined by Eq 2 as follows:

$$G_{ss} = \sum_{i=0}^N C_i Q_i \quad (2)$$

Since by definition, $C_i = w_i / v_i$, $w = \sum_{i=0}^N w_i$, and $C_m = w/v$, and by virtue of the sampling technique, $v_i/v = Q_i/Q$.

where:

w_i and v_i = mass of sediment and volume of mixture, respectively, collected from the i th element,

w , v , and C_m = mass of sediment, volume of mixture, and the “discharge-weighted” concentration, respectively, in and of the sample collected from the sampled area, and

Q = stream discharge through the sampled area.

Substituting the defining equations and the “sampling technique” equation in Eq 2 we obtain:

$$G_{ss} = \sum_{i=0}^N \left(\frac{w_i}{v_i} \right) \left(\frac{v_i Q}{v} \right) = \frac{Q}{v} \sum_{i=0}^N w_i = \frac{Q_w}{v} = C_m Q \quad (3)$$

13.1.5 In area integration, the entire flow cross section is sampled, hence, C_m and Q are the discharge-weighted sediment concentration and the stream discharge for the entire cross section. In depth integration, the sampled area is only that part of the stream cross section transversed by the intake nozzle at a single vertical. To determine the suspended-sediment discharged through an entire cross section, a series of verticals must be sampled by depth integration. By assuming that the discharge-weighted sediment concentration from each vertical represents a certain proportion of the total stream discharge, a discharge-weighted sediment concentration for the entire cross section can be obtained and combined with the total stream discharge to give the suspended-sediment discharge through the cross section. The accuracy of the samples improves with an increase in the number of sampling verticals.

13.1.6 In principle, the fixed slot performs depth integration at a single vertical. Instead of sampling along the vertical with a moving nozzle, the slot instantaneously samples the whole depth.

13.2 Depth Integration:

13.2.1 To sample by depth integration, collect water-sediment mixture along a vertical line throughout the entire depth by using a US D- or P-series sampler. While a sample is being collected, the sampler must be moved vertically at a uniform velocity termed the transit rate (16). With the D series, sampling is continuous through the entire depth. P series samplers are equipped with a valve so sampling may be continuous or interrupted in a series of segments through the depth. The only basic requirements are that at each sampling vertical, (1) the entire depth is sampled isokinetically, (2) the vertical transit rate in any given direction is the same over all parts of the depth and the rate never exceeds the product of K , (Fig. 8 (17) and Fig. 9 (18)) multiplied by the mean stream velocity at the vertical, and (3) sampling does not extend in one-way integration over half the distance greater than $K_e V_i / A_n$, or half this distance in two-way integration (K_e must be ≥ 0.4

and is the largest K value possible for a given nozzle area, A_n , and sample volume, V_i). Fig. 8 (17) and Fig. 9 (18) show graphs of K versus stream depth for standard nozzle sizes and for 1- and 2-pint containers. K is a dimensionless number.

13.3 Depth Integration Throughout a Flow Cross Section:

350 ml < Sample Volume < 440 ml

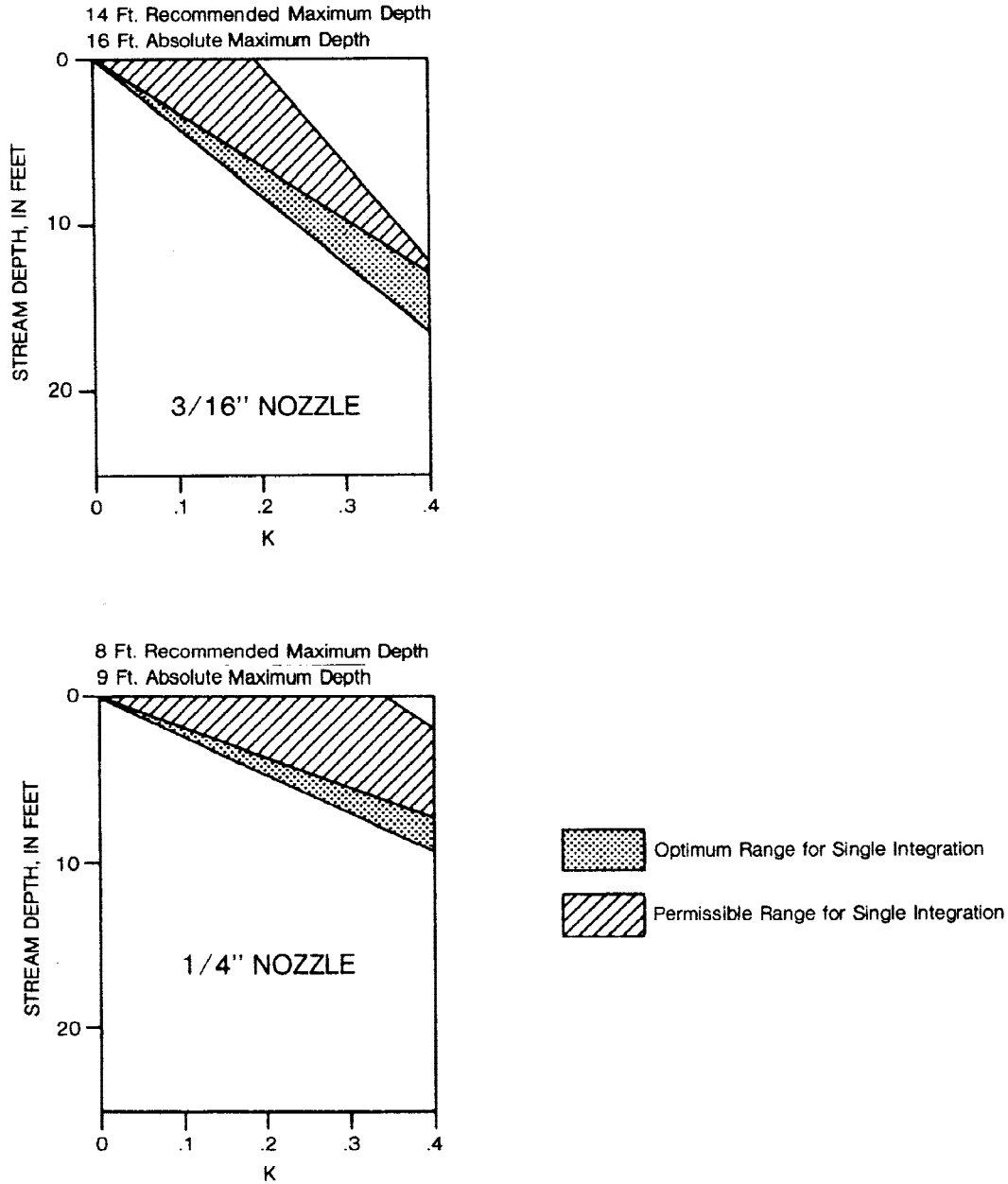

NOTE 1—1 in. = 25.4 mm, 1 ft = 0.3 m.

NOTE 2—Sampler's transit rate equals K multiplied by mean flow velocity at the sampling vertical.

FIG. 8 (17) Transit Rates for Depth-Integrating Sampler Type US D-74 with Pint Sample Container

13.3.1 Sampling throughout a cross section requires depth integration at several verticals spaced across the section. Two methods are commonly used: the equal-width-increment (EWI) method and the equal-discharge-increment (EDI) method. Either method is applicable, but depending on the situation, one method may be more convenient to apply than the other.

13.4 EWI (Equal-Width Increment) Method:

13.4.1 The EWI method produces for each increment a sample volume proportional to the stream discharge through the increment. All increments are of equal width and sampling verticals are located at the center of each increment. Furthermore, the transit rate is the same at all verticals. This method produces a gross sample in which the concentration of the sediment is weighted

650 ml < Sample Volume < 800 ml

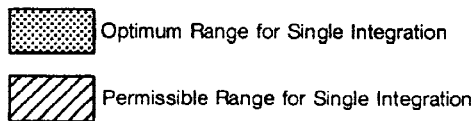
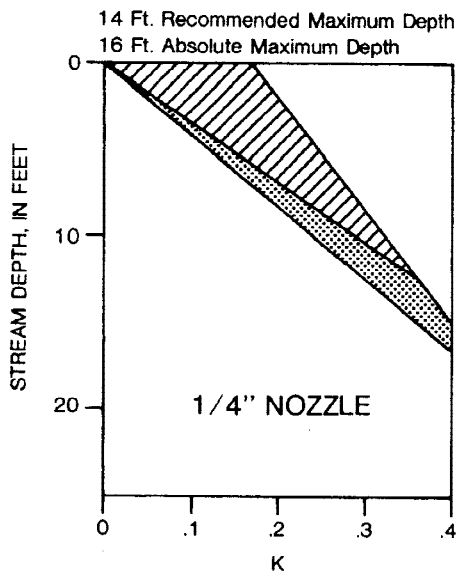
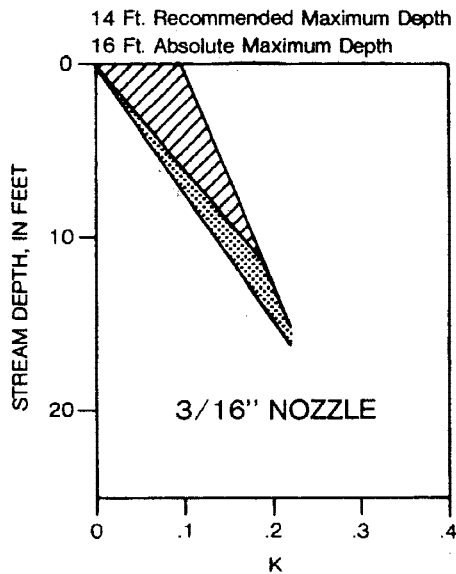

NOTE 1—1 in. = 25.4 mm. 1 ft = 0.3 m.

NOTE 2—Sampler's transit rate equals K multiplied by mean flow velocity at the sampling vertical.

FIG. 9 (18) Transit Rates for Depth-Integrating Sampler Type US D-74 with Quart Sample Container

both vertically and laterally according to stream discharge. The method is often used in shallow, sandbed streams where the discharge rating is unstable. The number of verticals depends upon the streamflow, the sediment characteristics of the stream, and the sampling accuracy desired. In general, not more than 25 verticals will be necessary.

13.4.2 Initially, select a sampling interval such that at least several sampling verticals are located within each part of the cross section where the suspended-sediment discharge is substantially different from the other parts. In sections that have a uniform shape and a relatively uniform lateral distribution of suspended-sediment discharge, 10 or more sampling verticals are ordinarily sufficient. In sections that have a non-uniform lateral distribution of suspended-sediment discharge, 20 or more verticals are required. Make selection of intervals on the basis of detailed information on the lateral distribution of stream discharge. If such information is unavailable make the selection only after a visual survey.

13.4.3 Establish the distance, S , of the first sampling vertical from the edge of the water, by first dividing the selected sampling interval, I , into the surface width, W , to ascertain the number of times, N , the interval will divide into the width evenly; then, compute the distance E from $E = \frac{1}{2}(W - NI)$; and finally, determine S from (a) $S = E + I/2$ when $E < I/4$, (b) $S = I/2$ when $E = 0$, or (c) $S = E$ when $E \geq I/4$. Subsequent sampling verticals are spaced according to the selected sampling interval. The last vertical is located at a distance of S units from the other edge of the water.

13.4.4 By experimentation, determine a transit rate at the vertical with the greatest water discharge per foot of width. The rate should be the slowest rate possible that falls within the optimum range designated in the appropriate graph in Fig. 8 (17) and Fig. 9 (18); this rate is also used at all other sampling verticals.

13.4.5 Lower the sampler to the water surface then, while keeping the nozzle out of the water, allow the sampler to become oriented with the flow. To sample, lower the sampler to the streambed and then raise the sampler to the surface at the transit rate determined from 13.4.4. Once established, maintain the transit rate while lowering and raising; furthermore, maintain the same transit rate at all verticals.

13.4.6 Move to the next vertical and repeat the sampling process. Water-sediment mixture from more than one vertical can be accumulated in a single bottle; however, care must be taken not to sample a vertical if the additional mixture will cause the bottle to overflow.

13.4.7 Mark each bottle with appropriate identification information. Prior to analysis, samples from all verticals may be composited.

13.4.8 The number of verticals initially selected may be reduced if it can be established that fewer verticals will provide the required accuracy.

13.5 EDI (Equal-Discharge Increment) Method:

13.5.1 The EDI method produces a group of samples each of which represents the same proportion of the total water discharge. If the samples are of equal volume (within 10 % of each other), they can be composited to form a single gross sample representative of the cross section. Otherwise, each sample must be analyzed separately then concentration values must be averaged numerically to obtain the mean discharge-weighted concentration for the cross section. The method is commonly used to sample rivers that have stable channels and stable discharge rating.

13.5.2 Use stream-gaging equipment or other appropriate apparatus to accurately measure the lateral distribution of water discharge in the cross section. Arrange the results to express accumulated discharge as a function of distance from one edge of the water. Select a sufficient number of verticals to be sampled so as to assure that at least one vertical is located in each part of the cross section where the stream discharge per foot of width is distinctly different from the other parts. For uniformly shaped sections where the lateral distribution of suspended sediment discharge is relatively uniform, seven sampling verticals will usually be satisfactory. For irregular sections more verticals are required; 14 verticals will usually be sufficient. Divide the number of verticals, N , into the total water discharge to determine the discharge to be represented by each sampling vertical, and then partition the width into N increments of equal discharge (19). Within each increment, sample at one vertical that is located so half of the increment's discharge is on one side of the vertical. The transit rate at a vertical must be uniform; but transit rates may differ among the verticals. Care must be taken not to overflow the sample container nor to exceed the maximum transit rate designated in the appropriate graph in Fig. 8 (17) and Fig. 9 (18).

13.6 Area Integration:

13.6.1 To sample by area integration, a traversing slot must be installed in accordance with 11.3. The slot must sample through the entire depth of flow and must sample isokinetically at all depths. At a uniform velocity, move the slot laterally across the flow. The sample consists of all liquid and sediment that enters the slot during one traverse. By this procedure an element of sampled volume is collected from every area element in the cross section. The ratio of the volume of a sample element to the volume of the entire sample is equal to the ratio of the discharge through the area element to the discharge through the entire cross section; hence, the concentration of the sample is "discharge weighted."

14. Techniques for Sampling Bedload

14.1 With direct-measuring bedload samplers, information on the bedload discharge is obtained by accumulating particles for a given period of time. To average spatial and temporal variations in the transport rate, a number of individual samples must be collected at each of several different lateral positions across the width of the flow section. Whenever it is possible, many samples should be collected and analyzed statistically to determine the optimum number necessary for a given accuracy. Because the rate of bedload transport may vary over the length of the individual bed forms, samples must be collected from a number of random positions along the lengths of several bed forms.

14.2 The number of lateral sampling positions required to adequately represent the discharge depends on the character of the lateral variations in transport. If both the transport rate and the bed form configuration are fairly uniform laterally, sampling sequentially at numerous points across a section provides samples from a number of random positions along the length of the bed forms. Hence, if traverses are made repetitively over a long enough time for several bed-form wave lengths to pass by the measuring section, the necessity to sample both randomly along the length of the bed forms and at different lateral positions is satisfied.

14.3 If the sampler is supported on a suspension line and if the velocities or bed-form relief is high, extreme care must be taken to avoid inadvertently collecting stationary bed material. As the sampler is lowered into layers of progressively lower velocity, the

drag force on the sampler continually decreases so the unit achieves an upstream motion which must be arrested before it strikes the bed and scoops bed material. Also, when the sampler is retrieved, there is a tendency for it to slide upstream prior to lifting off the bed; during this process scooping is possible. Scooping can sometimes be reduced by using a front stay-line to limit the downstream motion. Even with a stay-line, extreme turbulent pulsations combined with line elasticity may cause the sampler to oscillate on the bed and thereby scoop some material. Scooping can be minimized by installing devices on the sampler that cause its entrance to lift off the bed immediately upon retrieval.

15. Calculation

15.1 Calculation of Suspended Sediment Discharge:

15.1.1 Instantaneous suspended-sediment discharge can be computed from either Eq 1 (see 13.1.1) or Eq 3 (see 13.1.4). In either case, the accuracy of the result depends upon the representiveness of the samples and the accuracy of the stream-discharge measurements. When sediment discharge is determined from point-integrated samples in accordance with Eq 1, accurate measurements of vertical and lateral velocity gradients are required. These are best obtained from point velocities measured at the time of sampling. Suspended-sediment discharge computed according to Eq 3 requires accurate data on stream discharge at the time of sampling. At many locations, an accurate discharge can be obtained from the gage-height record and a stage-discharge rating curve. If an accurate rated discharge is not available, stream discharge should be measured immediately before sampling or immediately after sampling. When the stream discharge is measured prior to sampling and is measured according to conventional stream-gaging techniques, the measurement also provides the data necessary to locate the position of sampling verticals for the EDI sampling method.

15.1.2 If temporal variations in both stream discharge and suspended-sediment concentrations are significant, the quantity of suspended sediment, S , discharged through an area during a specified duration, T , must be determined as follows:

$$S = \int_T \int_A C U dA dT = \int_T Q_s dT \quad (4)$$

Whenever sampling is in accordance with depth- or area-integration procedures and concentrations are discharge weighted, Eq 4 becomes the following:

$$S = \int_T C_m Q dT \quad (5)$$

If, during time period T , C_m , or Q or both, are nearly constant, integration of Eq 5 can be simplified as follows:

$$\text{if } C_m = \text{constant} = \bar{C}, \text{ then } S = \bar{C} \int_T Q dT = \bar{C} \bar{Q} T \quad (6)$$

$$\text{if } Q = \text{constant} = \bar{Q}, \text{ then } S = \bar{Q} \int_T C_m dT = \bar{C}_m \bar{Q} T \quad (7)$$

$$\text{if } C_m = \text{constant} = \bar{C}_m \text{ and } Q = \text{constant} = \bar{Q}, \quad (8)$$

$$\text{then } S = \bar{C}_m \bar{Q} \int_T dT = \bar{C}_m \bar{Q} T$$

15.1.3 If the sample was collected by a slot sampler, the sample is a time-integrated composite. Measure both the mass of sediment and volume of the mixture in the sample container. Divide each quantity by R , the sampling ratio, to obtain the mass of sediment and volume of mixture discharged by the channel.

15.1.4 For a fixed slot

$$R = W_s / W_j \quad (9)$$

15.1.5 For the vertical traversing slot,

$$R = W_s T_i / W_j T_2 \quad (10)$$

where:

W_s = slot width,

W_j = width of the flow jet,

T_i = time the sampler is in the flow jet per traverse, and

T_2 = time for one complete traverse.

15.1.6 for the Coshocton-type sampler (20)

$$R = W_s / 2\pi r \quad (11)$$

where:

r = radial distance from the center of rotation.

15.1.7 Eq 1-6 are written without specification of units. In addition to the preferred units for concentration, mass of sediment per unit volume of mixture, concentration may be expressed in terms of volume of sediment per unit volume of water-sediment mixture or in terms of mass of sediment per unit mass of water sediment mixture. Parts per million by mass and milligrams per litre are commonly used. Stream discharge is ordinarily expressed as volume per unit time and sediment discharge is usually

expressed as mass per unit time. Because of the disparity in units, each of the equations requires a units conversion constant to make it dimensionally correct. The constant may involve the density of either the solid sediment or the water-sediment mixture in addition to mass, volume and time conversions. Reported values for concentration, stream discharge, and sediment discharge should be specified in metric units.

15.1.8 A sampler in the US series will not sample from a zone close to the streambed. This zone extends upward from the bed to a height equal to the distance from the sampler nozzle to the sampler bottom (see Table 1). As a result, depth-integrated samples collected with these samplers do not contain a contribution from this unsampled zone. When the suspended-sediment discharge is computed from Eq 3 by using the discharge-weighted concentration from such samples, there is an unaccounted portion of the total suspended-sediment discharge that is called the “unmeasured suspended-sediment discharge.” This discharge equals $Q''(C_m'' - C_m)$ in which Q'' is the water discharge in the unsampled zone and C_m'' is the discharge-weighted concentration in the unsampled zone. If the suspended sediment is distributed uniformly with depth so that $C_m'' = C_m$ or if the unsampled depth is very small relative to the total stream depth, then the unmeasured suspended-sediment discharge is usually considered to be inconsequential. However, if the suspended sediment concentration gradient increases significantly near the streambed or if the unsampled zone is a large fraction of the sampled depth, then the unmeasured discharge can be significant.

16. Precision and Bias

16.1 General Comments:

16.1.1 The selection of a sampling procedure and the evaluation of probable measurement error must be based on statistical parameters that are site dependent. These parameters can be estimated by analyzing results from an initial sampling program and by studying the nature of the sediment source. This initial sampling should be intensive, so that spatial variability and temporal variability can be determined. The basic data can also be used to estimate errors associated with more abbreviated programs or with more simplified sample-collecting procedures.

16.1.2 In a large river, sampling errors that occur because of a change in equipment or procedure can be estimated by comparing the data sets; however, this comparison will not reveal sampling errors that are common to all data sets. In some small streams and flumes, more accurate error analysis can be performed by comparing sediment discharge computed from samples with sediment discharge obtained from an independent measurement. This comparison will reveal all sampling errors regardless of their source. One experiment technique involves the use of a vibrating-type of material feeder. With a feeder, inject dry sediment into the flow at a suitable location upstream of the sampling site. Sediment discharge determined by sampling can be compared with the sediment injection rate. A correction must be made for sediment stored within the channel between the sampling site and the feeder.

16.1.3 Particles transported in suspension can be sampled more accurately than particles transported near or on the bed; consequently, for a given flow condition, sampling errors increase with an increase in the size of the particles in transport.

16.2 Suspended Sediment Samplers :

16.2.1 With the U.S. Series of samplers the largest errors occur while sampling close to the bed. Each sampler is constructed with its nozzle several centimeters above the bottom of the sampler; therefore, in a channel with a firm bed, the flow between the bed and the nozzle entrance is unsampled. Samplers should be chosen or designed to minimize this unsampled depth. In a channel having a bed composed of soft deposits or dunes, oversampling may result if the sampler is allowed to settle into the bed or into a trough. In deep streams the long length of submerged cable and the heavy weight of the sampler act to increase the time required to reverse the direction of sampler motion. This reversal time combined with the high concentration near the bed may result in oversampling.

16.2.2 A point-integrating or a depth integrating sampler should be checked to ensure it samples isokinetically. The first step is to adjust the balance of the sampler. The nozzle must be level to keep the entrance facing directly into the approaching flow. Adjustments can be made by adding or removing weights from the lower tail vane (See Fig. 3).

16.2.3 The hydraulic tests can be performed either in a flume or in a tow tank (21). If a flume is used, the breadth and depth must be sufficient to eliminate blockage effects between the walls of the flume and the body of the sampler. Tests indicate a flume width of 3.0 ft and a water depth of 6.0 ft are sufficient for testing P-61's, which are the largest of the commonly used suspended-sediment samplers. The test section of the flume must be longer than about 18 ft.

16.2.4 The first step in performing the hydraulic tests is to set the desired flow speed at the test point, which is usually taken midway between the flume walls and about two feet below the water surface. Measure the speed V_f with a rotating-bucket current meter. Remove the meter before proceeding to the next step.

16.2.5 If the sampler is a point integrator, close the sampling valve before positioning the nozzle at the test point. When all is ready, switch the valve open and at the same instant, start a timer. After a few seconds, close the valve and stop the timer.

16.2.6 Hoist the sampler above the flow and measure the volume collected in the sample container. The optimum volume is about 80 % of the bottle's rated capacity. If the volume is too small, discard the sample and collect another during a longer interval; if the volume is too large, shorten the interval.

16.2.7 The flow speed inside the nozzle, V_n (in feet per second), is given by the equation $V_n = KQ/T$ where Q is the sample volume in millilitres, T is the sampling interval in seconds, and K is a constant that depends on the diameter of the hole at the nozzle's entrance. K is 0.4143 for a 1/8 in. hole, 0.1841 for a 3/16 in. hole, 0.1036 for a 1/4 in. hole, and 0.0663 for a 5/16 in. hole.

16.2.8 For isokinetic sampling, V_n must match V_f ; however, in practice a 10 % deviation from this ideal condition is permissible.

In other words, V_n should be between $0.9 V_f$ and $1.1 V_f$. At flow speeds slower than about 1.5 ft/s, a larger deviation is acceptable.

16.2.9 V_n can be increased by enlarging the hole where the sample water emerges from the nozzle. Use a reamer with a taper of $\frac{1}{4}$ in./ft to cut away a small amount of material. Proceed cautiously: alternative between reaming and hydraulic testing. Once removed, the material cannot be replaced. Normally, this reaming operation is performed only once when a sampler is new.

16.2.10 If the sampler under test is a depth integrator, set V_f as explained in 16.2.3. Then lower the sampler and start the timer at the instant the nozzle penetrates the water surface. Hold the sampler at the test point for a few seconds, then hoist the sampler above the flow. Stop the timer when the nozzle breaks through the water surface.

16.2.11 Refer to 16.2.6 through 16.2.8 for computations and reaming.

16.2.12 If a tow tank is used for the hydraulic tests, the breadth and depth must be sufficient to eliminate blockage effects between the walls and sampler. Satisfactory results have been obtained in a tank 12 ft wide and 12 ft deep. The minimum length of the tank must be about 450 ft if the tests are to be run at speeds ranging up to 10 ft/s.

16.2.13 If the sampler is a point integrator, close the sampling valve before positioning the sampler at the test point. When the carriage has stabilized at the desired speed, open the sampling valve and at the same instant start the timer.

16.2.14 After a few seconds, close the valve and, at the same instant, stop the timer. Refer to 16.2.5 for the optimum sample volume. It may be necessary to collect samples smaller than the optimum in order to stop the carriage safely at the end of the run.

16.2.15 Refer to 16.2.6 through 16.2.8 for computations and adjustments. In the towing tests, V_f corresponds to the towing speed that is usually read from a meter aboard the towing carriage.

16.2.16 If the sampler is a depth integrator, the tow tank carriage must be moving at a steady speed before the sampler is lowered into the water. Start the timer at the instant the nozzle penetrates the water surface. Wait a few seconds, then hoist the sampler. Stop the timer at the instant the nozzle clears the water. Refer to 16.2.6 through 16.2.9 for computations and adjustments.

16.3 Slot Samplers:

16.3.1 To assure acceptable performance, slot samplers must be calibrated under conditions for which they were designed and are to be used. Their liquid sampling ratio and sediment sampling ratio should be calibrated for a wide range in discharge, sediment concentration, and sediment particle size.

16.3.2 The volumetric or weight method of calibration is recommended. If the stream discharge is known from the flow measuring device used in conjunction with the sampler, the liquid sampling ratio is readily determined from timed volumetric or weight measurements of discharge from the slot sampler. A calibrated tank will greatly facilitate the measurement of sample volume.

16.3.3 Determining the sediment sampling ratio is more difficult. Both the liquid and sediment discharge must be known. Thorough mixing of a known quantity of sediment in the flow upstream from the sampler and accurate measurements of sample volume and weight are required. When the sediment concentration in the sample is the same as the sediment concentration in the flow, the sediment sampling ratio is assumed to equal the liquid sampling ratio.

16.3.4 If either sampling ratio varies with stream discharge, a composite sample collected during a period of variable flow may not be representative of the total flow. Samples composited under such conditions must be discharge weighted to be truly representative.

16.3.5 Normally the assumption is made that the sediment sampling ratio is the same as the liquid sampling ratio. This may not be true if the sediment is composed of heavy particles. Calibration to determine the sediment sampling ratio is required.

16.4 Vertical Slot Samplers:

16.4.1 The liquid sampling ratio of the vertical slot, Fig. 5, (12) increases with increasing flow depth (discharge) and increases as W_s/W_j increases.

16.4.2 The accuracy of vertical slot samplers is dependent on the precision used in construction. The slot must be straight and must have knife-sharp edges. Flow within the sampler and from the sampler to the storage tank must be unrestricted to prevent sediment deposition.

16.5 Inclined Slot:

16.5.1 The accuracy of inclined slot samplers is dependent on the precision used in construction. The slot must be straight and have knife-sharp edges. Flow within the sampler and from the sampler to the storage tank must be unrestricted to prevent sediment deposition.

16.5.2 Limited test data (11) for the inclined slot (Fig. 4) show that the sampling ratio (S): (a) does not change with moderate changes in Reynolds number (from 1600 to 3600); (b) is relatively constant for angles of inclination (β) between 5° and 20° ; (c) increases as the ratio of slot width (W_s) to jet flow width (W_j) increases; (d) decreases as the angle (α) formed by the sides of the sampler increases; and (e) decreases as flow depth (discharge) increases. A relatively constant sampling ratio may be obtained for a range of flow depths (discharge) by using a slightly diverging slot that increases in width toward the downstream end. The width of the slot at any distance from the end of the flume will depend upon the shape (width) of the nappe at that point (22).

16.6 Coshocton Samplers:

16.6.1 Coshocton samplers will not function precisely as indicated by Eq 11. The liquid sampling ratio is influenced by the following: (a) the speed and uniformity of rotation of the sampling wheel and slot; (b) size and geometry of

the slot; (c) position of the slot relative to the jet; (d) flow approach conditions upstream from the sampler; (e) splashing; and (f) velocity and direction of the jet.

16.6.2 The width of the diverging slot at any radius (r) is approximately the following:

$$W_s = \frac{2 \pi r q/Q}{1 + 1.6 T}$$

where:

T = thickness of metal at the slot edge (in.), and

q/Q = desired proportion of stream discharge to be extracted; typically 0.01, 0.005, and 0.0033 for the 1, 2, and 3 ft samplers, respectively.

16.6.3 At high stream discharges the liquid sampling ratio tends to decrease rapidly with an increase in the stream discharge; therefore, the sampler should not be used if the discharge exceeds 80 % of flume capacity (23).

16.7 Bedload Samplers:

16.7.1 A bedload sampler must be calibrated to determine its sampling efficiency, which is defined as the ratio of the mass of bedload collected during any single sampling time to the mass of bedload that would have passed through the width occupied by the sampler entrance during the same time if the sampler had been absent. Many samplers have a sampling efficiency that varies from one particle size to another. Except for slot or pit samplers, which ordinarily have efficiencies close to 100 % for all conditions, the overall sampling efficiency of a specific sampler is not constant but varies with the size distribution of the bedload particles, the flow conditions, the rate of bedload transport, and the degree of filling of the sampler. The sampling efficiency is influenced, but is not solely determined by the sampler's hydraulic efficiency, which is the ratio of the volume of water that passed through the sampler entrance in a unit of time to the volume of water that would have passed through this entrance area if the sampler had been absent. Hydraulic efficiency and sampling efficiency can only be determined accurately through comprehensive and detailed procedures.

17. Keywords

17.1 fluvial sediment; ~~samplers~~; sampler calibration; samplers; sediment discharge; sediment transport

REFERENCES

- (1) Guy, H. P., and Norman, W. W., "Field Methods for Measurement of Fluvial Sediments," *Techniques of Water-Resources Investigations of the United States Geological Survey*, Book 3, Chapter C2, 1970, pp. 23–24.
- (2) Inter-Agency Committee on Water Resources, "Determination of Fluvial Sediment Discharge," *Rept. 14, A Study of Methods Used in Measurement and Analysis of Sediment Loads in Streams*; Subcommittee on Sedimentation, Minneapolis, MN, 1963, p. 28.
- (3) Bennet, J. P., and Nordin, C. F., Jr., "Suspended Sediment Sampling Variability," Chap. 17 in *Environmental Impact on Rivers (River Mechanics III)*, ed. and pub. by H. W. Shen, Fort Collins, CO, 1973.
- (4) Ehrenberger, R., "Direkte Geschiebemessungen an der Donau bei Wein und deren bisherige Ergebnisse" (Direct Bedload Measurements on the Danube at Vienna and Their Results to Date): *Vienna, Die Wasserwirtschaft*, Issue 34, 1931, pp. 1–9. Translation No. 39–20, U.S. Waterways Experiment Station, Vicksburg, MS.
- (5) Einstein, A. H., 1937, "Die Eichung des im Rhein verwendeten Geschiebefangens" (Calibrating the Bedload Trap as Used in the (Rhine): *Schweizer Bauzeitung*, Vol 110, No. 12. Translation, Soil Conservation Service, California Institute of Technology, Pasadena, CA.
- (6) Federal Interagency Work Group III 1978, Chapter 3—Sediment, in *National Handbook of Recommended Methods for Water Data Acquisition*, Office of Water Data Coordination, Geological Survey, U.S. Dept. of Interior, Reston, VA, pp. 3–20.
- (7) Skinner, J. V., and Beverage, J. P., 1976, Instructions for Sampling with Depth-Integrating, Suspended-Sediment Samplers D-74, D-74AL. D-74-TM, and D-74AL-TM, *Federal Inter-Agency Sedimentation Project*, St. Anthony Falls Hydraulic Laboratory, Minneapolis, MN, Fig. 1.
- (8) Inter-Agency Committee on Water Resources, "The Design of Improved Types of Suspended Sediment Samplers," Rept 6, *A Study of Methods Used in Measurement and Analysis of Sediment Loads in Streams*; Subcommittee on Sedimentation, Minneapolis, MN, 1952, pp. 60–63.
- (9) Hubbell, D. W., "Apparatus and Techniques for Measuring Bedload," *U.S. Geological Survey Water-Supply Paper 1748*, Washington, DC, 1964.
- (10) American Society of Civil Engineers, *Sedimentation Engineering*, by Task Committee. V. A. Vanoni, ed., ASCE, New York, NY, 1975, p. 342.
- (11) Barnes, L. L., and Frevert, R. K., "A Runoff Sampler for Large Watersheds, Part 1, Laboratory Investigations," *Agricultural Engineering*, Vol 35, No. 2, 1954, pp. 84–90.
- (12) Dendy, F. E., "Traversing Slot Runoff Sampler for Small Watershed," *ARS-S-15*, U.S. Dept. of Agriculture, Southern Region, 1973.
- (13) Parsons, D. A., "Coshocton-Type Runoff Samplers—Laboratory Investigations," *TP-124*, U.S. Dept. of Agriculture, Soil Conservation Service, 1954, Sheet 1.
- (14) Dendy, F. E., Allen, P. B., and Piest, R. F., Chapter 4, Sedimentation, in "Field Manual for Research in Agricultural Hydrology," *Agricultural Handbook No. 224*; Science and Education Administration, U.S. Dept. of Agriculture, Beltsville, IN 20705.
- (15) ASCE, *ibid*, p. 338.
- (16) Inter-Agency Committee on Water Resources, Report No. 6, *ibid*, p. 28.
- (17) Skinner, J. V., and Beverage, J. P., 1976, *ibid*, Fig. 2.
- (18) Skinner, J. V., and Beverage, J. P., 1976, *ibid*, Fig. 3.
- (19) American Society of Civil Engineers, *Sedimentation Engineering*, by Task Committee, V. A. Vanoni, ed., ASCE, New York, NY, 1975, p. 339.
- (20) Carter, C. E., and Parsons, D. A., "Field Test on the Coshocton-Type Wheel Runoff Sampler," *ASAE Transactions*, 1967, Vol 10, No. 1, pp. 133–135.

- (21) Beverage, Joseph P., and Futrell II, James C., “ Comparison of Flume and Towing Methods for Verifying the Calibration of a Suspended-Sediment Sampler,” Water Resources Investigations Report 86-4193 of the U.S. Geological Survey, 1986.
- (22) Barnes, K. K., and Johnson, H. P. “A Runoff Sampler for Large Watersheds, Part II. Design of Field Installation,” *Agricultural Engineering*, Vol 37, No. 12, pp. 813–815, 824.
- (23) Dendy, F. E., Allen, P. B., and Piest, R. F., *ibid*, pp. 248–50, 378–87.

SUMMARY OF CHANGES

Committee D19 has identified the location of selected changes to this standard since the last issue (D 4411 – 98) that may impact the use of this standard.

- (1) Sections 9.2.3, 9.2.8, 12.1, 12.4, 12.5, 13.2.1, 16.2.7, Table 1, Fig. 8, and Fig. 9 were revised to describe changes in technique and technology.

ASTM International takes no position respecting the validity of any patent rights asserted in connection with any item mentioned in this standard. Users of this standard are expressly advised that determination of the validity of any such patent rights, and the risk of infringement of such rights, are entirely their own responsibility.

This standard is subject to revision at any time by the responsible technical committee and must be reviewed every five years and if not revised, either reapproved or withdrawn. Your comments are invited either for revision of this standard or for additional standards and should be addressed to ASTM International Headquarters. Your comments will receive careful consideration at a meeting of the responsible technical committee, which you may attend. If you feel that your comments have not received a fair hearing you should make your views known to the ASTM Committee on Standards, at the address shown below.

This standard is copyrighted by ASTM International, 100 Barr Harbor Drive, PO Box C700, West Conshohocken, PA 19428-2959, United States. Individual reprints (single or multiple copies) of this standard may be obtained by contacting ASTM at the above address or at 610-832-9585 (phone), 610-832-9555 (fax), or service@astm.org (e-mail); or through the ASTM website (www.astm.org).