



Designation: ~~D 5073—90 (Reapproved 1996)~~^{ε1} 5073 – 02

Standard Practice for Depth Measurement of Surface Water¹

This standard is issued under the fixed designation D 5073; the number immediately following the designation indicates the year of original adoption or, in the case of revision, the year of last revision. A number in parentheses indicates the year of last reapproval. A superscript epsilon (ε) indicates an editorial change since the last revision or reapproval.

~~ε¹ Note—Keywords were added editorially in July 1996.~~

1. Scope

1.1 This practice guides the user in selection of procedures commonly used to measure depth in water bodies that are as follows:

	Sections
Procedure A—Manual Measurement	6 through 11
Procedure B—Electronic Sonic-Echo Sounding	12 through 13
Procedure C—Electronic Nonacoustic Measurement	14 through 15

The text specifies depth measuring terminology, describes measurement of depth by manual and electronic equipment, outlines specific uses of electronic sounders, and describes an electronic procedure for depth measurement other than using sonar.

1.2 The references cited and listed at the end of this practice contain information that may help in the design of a high quality measurement program.

1.3 The information provided on depth measurement is descriptive in nature and not intended to endorse any particular item of manufactured equipment or procedure.

1.4 This practice pertains to depth measurement in quiescent or low-velocity flow. For depth measurement related to stream gaging see Test Method D 3858. For depth measurements related to reservoir surveys see Guide D 4581.

1.5 *This standard does not purport to address all of the safety concerns, if any, associated with its use. It is the responsibility of the user of this standard to establish appropriate safety and health practices and determine the applicability of regulatory limitations prior to use.*

2. Referenced Documents

2.1 *ASTM Standards:*

⁺Precision and Bias This

¹This practice is under the jurisdiction of ASTM Committee D-19 on Water and is the direct responsibility of Subcommittee D19.07 on Sediments, Geomorphology, and Open-Channel Flow.

Current edition approved ~~May 25 and Oct. 26, 1990~~; July 10, 2002. Published ~~December 1990~~; August 2002. Originally published as D 5073-90 (1996)^{ε1}

D 1129 Terminology Relating to Water ²

D 3858 Test Method for Open-Channel Flow Measurement of Water by Velocity-Area Method ²

D 4410 Terminology for Fluvial Sediment ²

D 4581 Guide for Measurement of Morphologic Characteristics of Surface Water Bodies ³

3. Terminology

3.1 *Definitions*—For definition of terms used in this practice refer to Terminologies D 1129 and D 4410.

3.2 *Definitions of Terms Specific to This Standard:*

3.2.1 *bar-check, n*—a method for determining depth below a survey vessel by means of a long, narrow metal bar or beam suspended on a marked line beneath a sounding transducer.

3.2.2 *bar sweep, n*—a bar or pipes, suspended by wire or cable beneath a floating vessel, used to search for submerged snags or obstructions hazardous to navigation.

3.2.3 *beam width, n*—the angle in degrees made by the main lobe of acoustical energy emitted from the radiating face of a transducer.

3.2.4 *bottom profile, n*—a line trace of the bottom surface beneath a water body.

3.2.5 *sonar, n*—a method for detecting and locating objects submerged in water by means of the sound waves they reflect or produce.

3.2.6 *sound, vt*—to determine the depth of water **(1)**. ⁴

3.2.7 *sounding line, n*—a rope or cable used for supporting a weight while the weight is lowered below the water surface to determine depth.

3.2.8 *sounding weight, n*—a heavy object usually of lead, that may be bell-shaped, for use in still water and soft bottom materials or torpedo shaped with stabilizing fins, for use in flowing water.

3.2.9 *stray, n*—spurious marks on the graphic depth records caused by surfaces other than the bottom surface of a water body below the sounding vessel.

3.2.10 *subbottom profile, n*—a trace of a subsurface horizon due to a change in the acoustic properties of the medium through which the sound energy has traveled.

3.2.11 *towfish, n*—a streamlined container, containing acoustical equipment for sounding depth, and designed to be pulled behind or beneath a survey vessel.

3.2.12 *transducer, n*—a device for translating electrical energy to acoustical energy and acoustical energy back to electrical energy.

3.2.13 *transducer draft, n*—the distance from the water surface to the radiating face of a transducer.

3.2.14 *vertical control, n*—a horizontal plane of reference used to convert measured depth to bottom elevation.

4. Summary of Practices

4.1 These practices include the following three general techniques for acquiring depth measurements in surface water:

4.1.1 The first general technique is to determine depth by manual procedures. The equipment to perform these procedures may be most readily available and most practical under certain conditions.

4.1.2 The second general technique is to determine depth by electronic sonic-echo sounding procedures. These procedures are most commonly used because of their reliability and the variety of instruments available that meet specific measuring requirements.

4.1.3 The third general technique is to determine depth by an electronic procedure other than acoustic sounding. A procedure using ground penetrating radar is currently being used for measuring water depth for specific applications.

5. Significance and Use

5.1 This is a general practice intended to give direction in the selection of depth measuring procedures and equipment for use under a wide range of conditions encountered in surface water bodies. Physical conditions at the measuring site, the quality of data required, and the availability of appropriate measuring equipment govern the selection process. A step-by-step procedure for actually obtaining a depth measurement is not discussed. This practice is to be used in conjunction with a practice on positioning techniques and another practice on bathymetric survey procedures to obtain horizontal location and bottom elevations of points on a water body.

PROCEDURE A—MANUAL MEASUREMENT

6. Scope

6.1 This procedure explains the measurement of water depth using manual techniques and equipment. These include the use of sounding rods, sounding lines, sounding reels, or a bar sweep.

² Annual Book of ASTM Standards, Vol 11.01.

³ Annual Book of ASTM Standards, Vol 11.02.

⁴ The boldface numbers in parentheses refer to a list of references at the end of this practice.

6.2 Description of techniques and equipment are general in nature. Techniques and equipment may need to be modified for use in specific field conditions.

7. Significance and Use

7.1 Prior to the development of acoustic sounding equipment, manual techniques provided the only means of depth measurement. Some circumstances may still require sounding by manual techniques such as shallow areas where depth is not sufficient for acoustic sounding. Manual procedures continue to serve several useful purposes such as the following:

- 7.1.1 To search for and confirm the minimum depths over shallow area of sunken obstacles.
- 7.1.2 To confirm bottom soundings in areas with submerged vegetation, or other soft bottom materials.
- 7.1.3 To assist in obtaining bottom samples.
- 7.1.4 To calibrate electronic sounding equipment.
- 7.1.5 To suspend other measuring instruments to known depths for making various physical or chemical water quality measurements (2).

8. Sounding Rod (Manual Procedure)

8.1 The sounding rod (or sounding pole) can be used to measure depth over extensive flat, shallow areas more easily and more accurately than by other means. Use of the sounding rod should be restricted to still water or where the velocity is relatively low, and to depths less than 12 ft (3.7 m). Sounding rods are usually not used in depths over 6 ft (1.8 m) except to provide supplemental soundings to aid in interpreting analog depth records. A weighted, flat shoe (see Fig. 1) should be attached to the bottom of the rod to prevent it from penetration of the bottom sediments. The rod may be graduated in feet and tenths of a foot; zero being at the bottom of the shoe (3).

8.2 Modern sounding rods may be made of light-weight metals for strength, neutral buoyancy, and sound transmitting capability. An experienced operator can measure the water depth and can distinguish the relative firmness of the bottom material by the feel of the rod and the tone produced by the metal pole as it contacts the bottom (4).

8.3 When sounding in still water the operator should lower the rod into the water until the bottom plate makes contact with the bottom surface. After determining that a firm bottom material has been encountered, the water surface level is visually read on the rod. When sounding in flowing water, to achieve vertical sounding, a long wire or cable anchored upstream and attached to the lower end of the rod may be necessary.

9. Sounding Line (Manual Procedure)

9.1 The sounding line (see Fig. 2) can be used to measure depths of large magnitude but is seldom used for depths greater than 15 ft (4.57 m). The sounding line should be of a material that does not shrink or stretch, or lengthen from wear or corrosion of

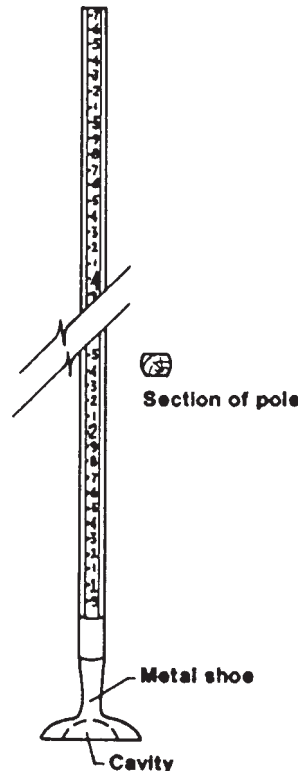

FIG. 1 Graduated Sounding Rod with Shoe Attached

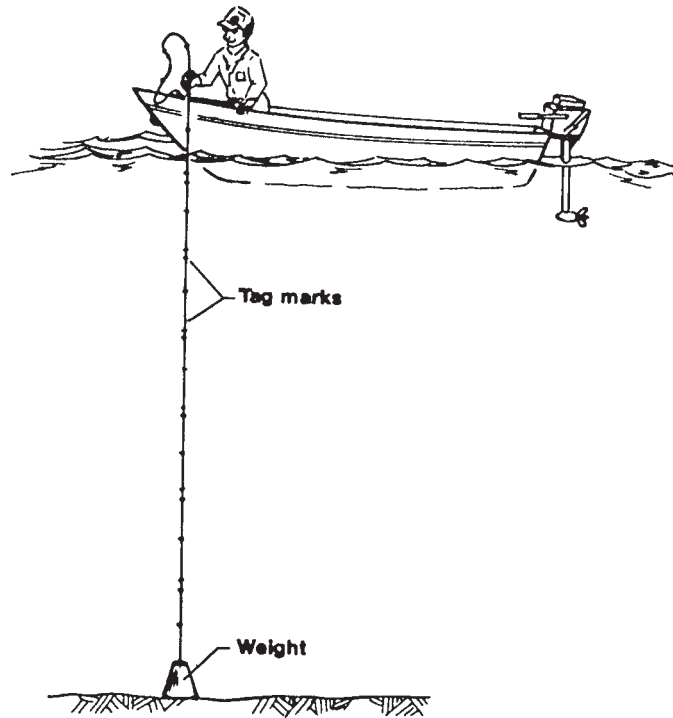

FIG. 2 Sounding Line Used from Small Boat

the material as will occur in chain links over several years of use. Though manila rope and cotton, or other materials that require prestretching before use, have been employed for large depths, small-diameter high-strength steel cable wound and released from a reel with a gear driven depth indicator are readily available and greatly simplify the work (1). The stretch of the high-strength cable is very small for its intended use, and therefore, a considerable length of cable may be used without introducing significant error. Depth indicators, calibrated in either inch-pound or metric units, or both, are available (5).

9.2 Markings on the sounding line should be easy to see and understand to avoid making errors in determining the readings. For sounding relatively shallow depths, marking at 0.5-ft intervals with different colors to identify the 1, 2, and 10-ft intervals is recommended. Care must be exercised so that the first marker is the correct distance from the bottom of the sounding weight when the weight is attached. When sounding, depths are obtained from the difference in readings at an index point on the bridge or boat rail, when the base of the sounding weight is at the water surface, and when it is at the bottom. A short steel tape or folding rule is usually employed to measure the fractional distance from the line markers to the reference point. Within the minimum 0.5-ft markings depths are estimated and recorded to the nearest 0.1 ft. For sounding in deep water, a sounding reel with depth indicator and an unmarked high-strength steel cable is recommended (4).

9.2.1 When the metric system of units is used, the sounding line for use in shallow depths is usually marked at 0.5-m intervals with different colors to identify the 1 and 2-m intervals. Depths are recorded to the nearest 0.01 m.

9.3 Weights used in sounding are usually of lead, aluminum, or brass. For application in still water, the weights are bell-shaped (see Fig. 3a) and made of cast aluminum or lead. The amount of weight should be from 5 to 10 lb (2.3 to 4.5 kg).

9.3.1 For application in flowing water, the weight should be of circular cross section and streamlined with fins (see Fig. 3b) to turn the weight nose first into the current to offer a minimum of resistance to the flow. The amount of weight should be varied, depending on the water depth and flow velocity at a cross section. A rule of thumb is that the weight in pounds should be greater than the maximum product of velocity and depth in the cross section. If debris or ice is flowing or the stream is shallow or swift, use a heavier weight than the rule designates. A variety of sizes of sounding weights from 15 to 300 lb (7 to 136 kg) should be available with appropriate means of attaching to the sounding line (1). Sounding weights should always be attached to the sounding line using a hanger bar, clevis, snap hook, or thimble of brass or stainless steel to protect the line from wear or damage.

9.4 The procedure for making soundings will vary depending on depth, current velocity, and means of locating where the soundings are taken. Once at the location where a depth measurement is needed, the basic procedure is to lower the weight until the bottom of the weight is at the water surface. When using a marked sounding line, the distance is read from the sounding line at a reference point on the bridge or boat after which the weight is lowered to the bottom, and a new distance is read from the line and recorded. When using a sounding reel the indicator is set to zero after which the weight is lowered to the bottom and the depth is read and recorded. It is usually of some importance, especially when sounding an uneven bottom, to have the locations of the soundings accurately known relative to the surroundings. When sounding from a boat using weighted line, the boat should be stationary and should remain at that position until the sounding has been completed and the location is determined.

9.5 Sounding through the ice cover of a lake or river may be taken after boring holes in the ice with an ice auger. In this case,

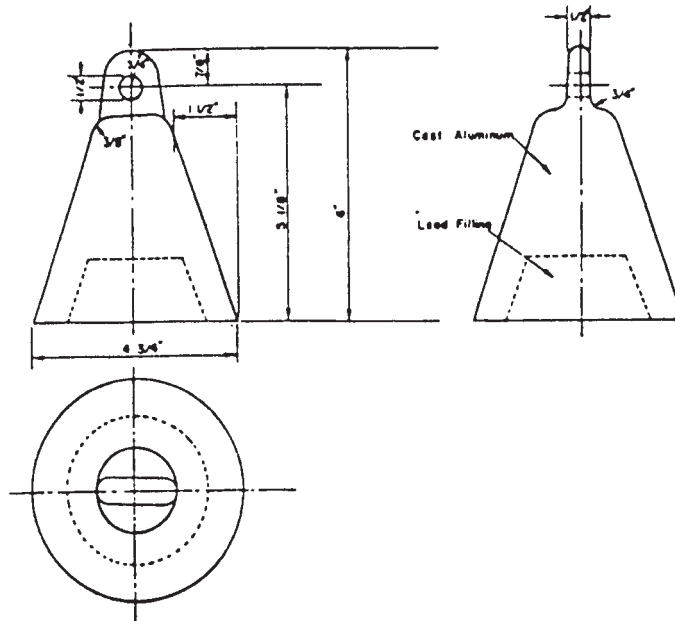

(a) Bell Shaped Sounding Weight (4)

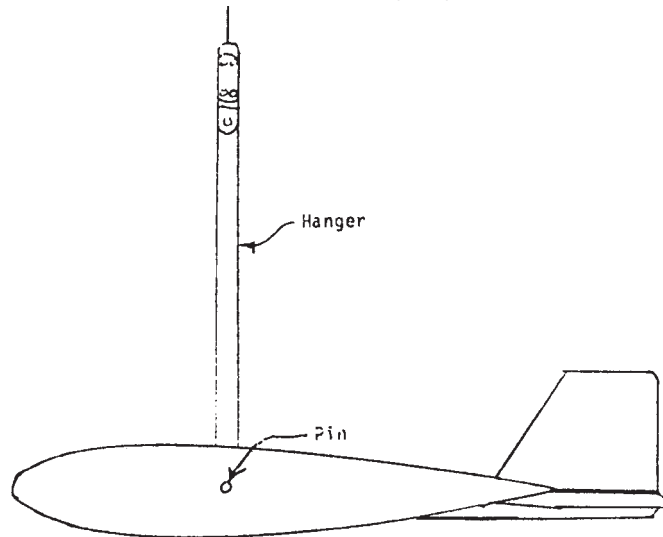

(b) Torpedo Columbus-Type Sounding Weight

FIG. 3 Typical Weights Used with Sounding Line

a marked sounding line with an appropriate sounding weight attached at the end, is lowered through the hole and the determined depth is recorded.

10. Sounding Reels (Manual Procedure)

10.1 Sounding reels (see Fig. 4) are used with high strength cable where heavy weights are required or where depths are great. These reels are usually very sturdily constructed having a braking system for controlling rotation of the reel as the cable is let out. For hand operated reels, the hand cranks are hinged to allow the crank to be disengaged from the shaft while the wire is let out and engaged for reeling in. Various devices are employed to drive a counter registering the amount of cable let out from which the depth below water surface is determined. These sounding reels may also be electrically driven, in that case, they may have a depth capacity of more than 5000 ft (1524 m) (1).

11. Bar Sweep (Manual Procedure)

11.1 The bar sweep is commonly used to search for and locate any shoal or obstruction within or above navigation depth that may present a hazard to navigation. It augments the hydrographic survey in navigable waters by locating shallow submerged areas that may go undetected by the usual hydrographic procedures. The bar sweep (see Fig. 5) consists of a bar (steel pipe) suspended beneath the survey vessel by graduated wire or cable from hand operated drums. The drums may be mounted either off the stern



FIG. 4 Hand-operated Sounding Reel (1)

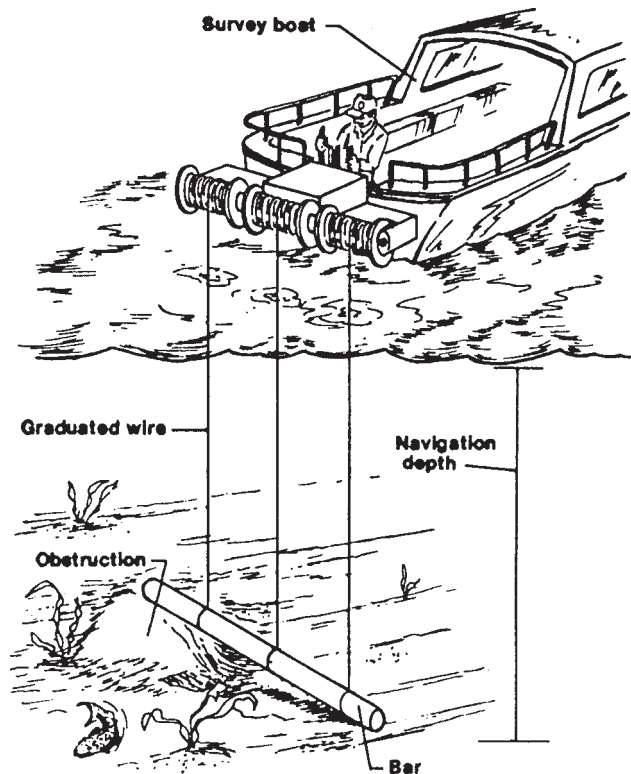

FIG. 5 Bar Sweep for Locating Shoals

or at the port and starboard gunwale. Each end of the bar should be packed with lead to add weight and to reduce lift when underway. Pipe weight is the major factor in allowable vessel speed. Trial and error variations are usually necessary to determine the best combination. In a normal operation, the bar is lowered to navigation depth and the vessel moves forward to sweep an area. Whenever a shoal is encountered, the operator raises the bar until it clears the obstruction. The shoal depth and position is then recorded. The bar is then returned to navigation depth and the survey continues (2).

PROCEDURE B—ELECTRONIC SONIC-ECHO SOUNDING

12. Scope

12.1 This procedure is applicable to the measurement of water depth using electronic sonic-echo sounding techniques and equipment. Because of the large variety of instrumentation currently available, this discussion is limited to types of equipment in most common use.

12.2 Discussions of the techniques used include methods of measurement, criteria for selection of sounding frequency and recording equipment, means for achieving quality assurance, and factors to consider in interpreting depth records.

13. Sonic-Echo Sounding (Electronic Procedure)

13.1 Water depths are most commonly obtained by echo sounders that record a continuous profile of the bottom surface of the water body under the vessel. Echo sounders measure the time required for a sound wave to travel from its point of origin to the bottom and the reflected wave to return. The sounder then converts this time interval to distance or depth below the face of the transducer. The transmission of sound is dependent on certain properties of the water and the reflecting surface. For a sound wave to travel at a constant velocity from the surface to bottom and be completely reflected off the bottom, the water must have the same physical characteristics throughout its entire depth and the bottom must be a perfect reflector. Because such conditions do not exist in nature, echo sounders are usually designed to permit adjustments for variations in the velocity of sound in water and wave attenuation (2).

13.2 Measuring Principles:

13.2.1 Echo sounding equipment is designed to generate the sound wave, receive and amplify the returning echo, measure the intervening time interval, convert the time interval into units of depth, and record the results graphically, digitally, or both. The echo sounder only measures time (that is, the time it takes for a sound wave to travel from the transmitter to the bottom or other reflecting surface and back again). The time interval is converted mechanically or electronically to depth beneath the transmitter by the following equation:

$$\text{depth} = 1/2 vt$$

where:

v = the velocity of sound in water, ft/s (m/s), and

t = the time for the pulse to travel from the transmitter to the reflective surface and back to the transmitter, s.

Because velocity of sound varies with water density, that is a function of temperature, salinity, suspended solids, and depth, a means of correcting the resulting measurements for variations in the velocity of sound must be employed to ensure an acceptable measurement accuracy (2). The methods for adjustment are presented in 13.6.

13.2.2 The sound waves transmitted by an echo sounder may be varied in frequency, duration, and shape of the acoustical beam (see Fig. 6). The sound wave may be dispersed in all directions, or contained and concentrated into a narrow beam by a reflector. The suitability of an echo sounder to meet a given requirement depends on how these variables are combined (2).

13.3 Frequency Selection:

13.3.1 An echo sounding transducer is used to convert electrical energy pulses to acoustical energy. The acoustical energy pulses are then transmitted through a liquid medium and the returning echoes are detected and reconverted back to electrical energy. These energy pulses are then amplified and used to compute and record depth. Transducers are usually designed to operate on specific frequencies, depending on the application and depth range (2).

13.3.2 Low-frequency transducers, those operating below 15 kHz, produce sound waves having low absorption rates and high penetrating power. These characteristics make them useful for deep soundings and penetration of the fine deposited material on the bottom of a river or lake. These transducers cannot be used to accurately measure very shallow depths, and they are very susceptible to noise interference in the more audible frequency range. Because of their long wavelengths the lower frequency pulses cannot be beamed directionally unless the transducers are very large (2). The use of low-frequency transducers for subbottom penetration is discussed in 13.10.

13.3.3 Medium-frequency transducers (15 to 50 kHz) may be used for water depths less than 1800 ft (549 m) and in situations when it is necessary to penetrate a layer of low density sediment suspended above more compacted sediments. In this range, the transducers may be small in size, the maximum dimension being 8 in. (20.3 cm) or less. These transducers can generate a comparatively narrow beam that results in a more accurate definition of the bottom.

13.3.4 High-frequency transducers (greater than 50 kHz) overcome most of the disadvantages of the low and medium-frequency transducers. With small transmitting units, the ultrasonic acoustical energy can be directed and concentrated in a relatively narrow water column. By narrowing the beam angle, side echoes can be reduced, and a more detailed profile of an irregular bottom can be achieved. In addition, shallow depths can be measured more accurately. Due to greater attenuation of the sound wave, the high frequencies are ineffective in very deep water (2).

13.4 Recording Soundings:

13.4.1 Analog recorders usually employ one of two methods for registering depth on a chart.

13.4.1.1 In the first method, the depth is recorded by a stylus mounted on a rotating arm that makes a mark on dry, electrosensitive, calibrated paper. The stylus passes over the chart paper at a constant speed marking the chart at the zero (initial) point, at a point designating the draft of the transducer, and at a point representing bottom depth. As continuing echoes are received from the bottom, a bottom profile is recorded (see Fig. 7). The horizontal scale of the plot is determined by the chart speed set by the operator.

13.4.1.2 In the second method, the depth is recorded by a fixed-head thermal recording device (6). The printing mechanism consists of a nonmoving print head containing hundreds of thermal dots heated precisely at the proper time to print the chart. The only moving parts on thermal print recorders are the motor and roller assembly that moves the paper across the printhead. Unlike

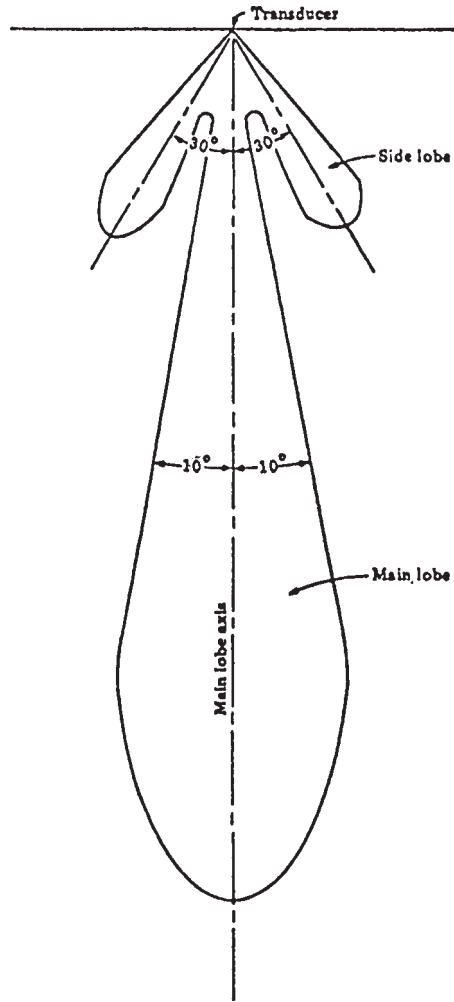

FIG. 6 Shape of a General-purpose Echo Sounders' Acoustical Beam (2)

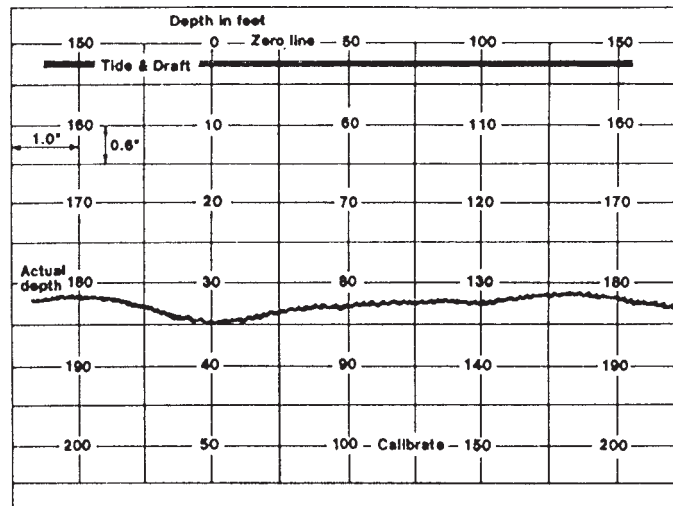

FIG. 7 Analog Bottom Profile Charted with Stylus

moving-stylus type recorders, the chart and motor timing on the thermal print recorders have no effect on depth measurement accuracy. Thermal print recorders begin with blank thermal paper. The scale grids and other chart features are preprogrammed to be generated by these units, allowing for a variety of chart formats (see Fig. 8).

13.5 Errors in Measurement:

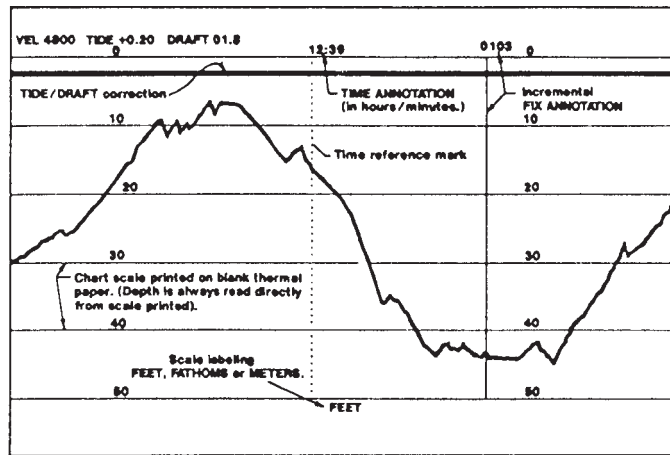

FIG. 8 Analog Bottom Profile Charted by Thermal Printer

13.5.1 Factors that lead to error in depth measurement are numerous and should be recognized when conducting a bathymetric survey or analyzing graphic depth recordings. For a detailed description of these errors see Ref (2). The most significant factors are described in 13.5.2-13.5.9.

13.5.2 *Velocity of Sound Wave Propagation*—The velocity of a sound wave traveling through water varies with temperature and density. It is, therefore, necessary to check the effective velocity of sound in a given body of water to achieve the depth accuracy required. In a deep reservoir, temperatures may vary as much as 45°F (25°C) between the surface and the bottom. In an estuary, salinity may also vary in both the vertical and horizontal direction, thus causing density to vary. Calibration of the sounding instrument should be made by the survey crew, at appropriate times to adjust the depth readings for changes in water temperature and density (see 13.6).

13.5.3 *Signal Transit Time*—Water depth is determined by the time required for a signal to travel from the transducer, strike a reflective surface, and return to the transducer. With the high quality instruments currently available, errors in time measurement are insignificant (7).

13.5.4 *Transducer Location*—The draft or vertical location of the transducer with respect to water surface can be set into most high precision echo sounders. The vertical location, when set for static conditions, will change with the motion of the boat. The effect of boat motion on draft, may be corrected during calibration of the instrument.

13.5.5 *Wave Action*—The vertical and rotational motion of a boat due to wave action can result in severe fluctuations in the bottom trace. Some smoothing of the trace may be necessary during data processing to eliminate the fluctuations. The motion effects, described as survey vessel roll, pitch, yaw, and heave, were once difficult errors to correct in hydrographic surveying. Measurements from accurate, compact, and relatively inexpensive motion compensation instruments have significantly reduced these errors (7).

13.5.6 *Bottom Conditions*—The condition of the reflective surface of a reservoir or river bottom may vary widely, resulting in a sounding chart that gives an erroneous impression of the actual bottom profile. Vegetation attached to or suspended above the bottom, isolated boulders, or submerged man-made objects, may produce a nonrepresentative bottom profile. Depending on the purpose of the survey, the cause of these bottom reflections may have to be determined by other means before choosing to eliminate them from the trace.

13.5.7 *Nature of Bottom Sediments*—Very low density sediment, suspended as a nepheloid layer or zone above more compacted sediments, can result in an erroneous depth reading when a transducer with a frequency higher than 50 kHz is used. A waterway bottom may be described in nautical terms as any water/solid interface level that blocks or impedes the passage of ships, boats, or barges. A low or medium-frequency transducer may be used to determine depth to the more consolidated sediment layer.

13.5.8 *Tidal Effects*—When surveying in tidal zones of rivers and estuaries, a continuous record must be kept of tidal fluctuations within the area during the surveys in order to adjust the depth readings for the changing water surface. The measured depths are generally referred to a reference level, such as mean sea level. By exercising good technique in determining tidal changes and making tidal corrections, the errors in measuring bottom elevations can be significantly reduced.

13.5.9 *Other Causes*—Errors may occur due to special conditions during a survey that may be either unknown or overlooked by the survey crew. Examples of these conditions are as follows: a reservoir water surface elevation may fluctuate appreciably due to inflow or outflow, thus changing the conditions for vertical control during the survey; when downstream flow occurs in narrow canyon areas or in river portions of a reservoir, a water surface slope may extend in the upstream direction and produce error when a constant reservoir water surface elevation is assumed for vertical control; a constant wind blowing from one side of a water body to another may raise the water surface on the downwind side of the water body and introduce error should a specific water surface elevation be assumed for vertical control (8). Real time kinematic global positioning systems (RTK GPS) can provide 2 to 5 centimeter accuracies both horizontally and vertically for the receiver on the moving survey vessel. The proper use of RTK GPS technology can monitor and minimize the errors from tidal and other vertical effects (7).

13.6 Calibration:

13.6.1 Depth measurements by an echo sounder require a number of corrections. The largest correction results from the variability of sound velocity in water. The velocity varies with the temperature, salinity, and depth of water. In fresh water at 60°F, echo sounders are generally calibrated for a sound velocity of 4800 ft/s (1463 m/s). The indicated depth given by the echo sounder needs to be corrected for the difference between the calibrated velocity and the actual velocity determined by the water temperature and salinity. This can be accomplished by several methods. One method is to measure the temperature and salinity of the water at various depths, and using predeveloped tables and graphs, correct the depth readings on that basis. A more direct method is to construct calibration curves from bar-check data for a particular instrument and using these curves to make corrections. A third method is available on many echo sounders where adjustment control is offered to adjust velocity of sound to local conditions.

13.6.2 A bar-check (see Fig. 9) is the preferred method used to verify the accuracy of an echo sounder and to determine corrections for instrument and velocity error. However, reliable and accurate bar-checks can be made only under favorable conditions. When the water surface is calm and there is little differential current or wind effect near the vessel, bar-checks can be obtained in depths as great as 200 ft (61 m). Under less favorable conditions, accurate bar-check depths may be reduced to 10 ft (3.05 m). In moderate depths where bar-checks can be obtained over the full depth range of a survey, corrections to soundings can compensate for the difference between the calibration velocity of the instrument, the actual velocity of sound in the water, and for instrumental errors (2).

13.6.3 The bar-check apparatus must be a sound-reflecting surface that can be lowered to a known depth below the transducer. A variety of calibration targets have been used such as a section of standard pipe sealed at both ends, a rectangular section of sheet steel, a spherical metal ball, or a section of I-beam or T-beam. The overall dimensions of the target should depend on the type of survey vessel, location of the transducer, and the depth range to be covered in the bar-check. For transducers mounted in the hull of a vessel, the overall length of the target should be about the same as the beam width of the vessel, allowing the bar to be passed over the stern and lowered beneath the transducer. A metal ball used as the target may be lowered through a well in the hull. Safety precautions should be employed to keep the target and cables away from the boat propeller (2).

13.6.4 Flexible wire or line with a wire core is used to suspend the target below the sounding transducer. The lines should be marked in a clear readable manner at desired measuring intervals.

13.6.5 The survey crew using echo sounders for hydrographic surveying should make bar-checks and record the results.

13.6.5.1 In protected waters where conditions are favorable and survey depths lie within the bar-check range, bar-checks should be made at least twice daily, prior to beginning depth measurements and at the end of the day. Comparisons are recorded during both descent and ascent of the bar, at predetermined intervals below the surface, and throughout the depth range of the survey. An additional observation is made at a depth of 5 to 6 ft (1.5 to 1.8 m), if the soundings can be recorded.

13.6.5.2 Where all or some of the depths within the project area are beyond bar-check range, bar-check data may be supplemented by taking manual soundings of total depth, comparing these measurements with the echo sounding measurement, and determining velocity correction. A calibration curve can be generated which can be used to correct future depth recordings.

13.6.5.3 Bar-check data should be recorded in a comparison log, or on the depth chart in those cases where the adjustment control is available on the echo sounder.

13.6.6 A velocity meter is an instrument that directly measures sound velocity and can be used to correct sounding data (7).

13.6.6.1 A velocity meter consists of a probe attached by a waterproof cable to a hand-held controller. The cable is numerically labeled with some using pressure sensors for depth determinations that minimize slant errors with the cable.

13.6.6.2 The cable is lowered by the survey crew in the study area being surveyed. Velocity meters can be cast in rougher water conditions than with the bar check method.

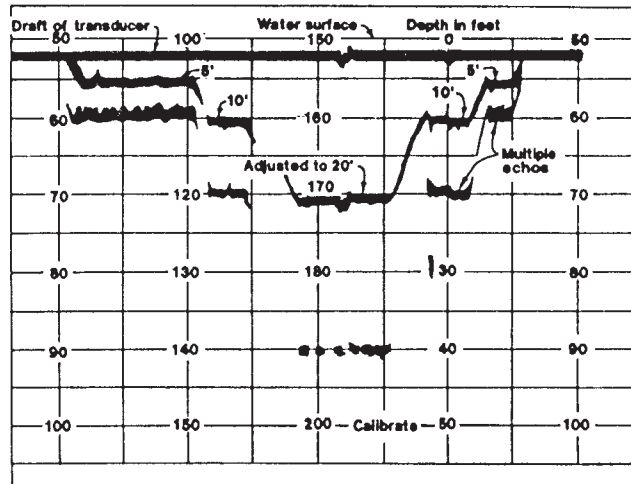

FIG. 9 Results of a Bar-check

13.6.6.3 Velocity meter output is usually the speed of sound as a function of water depth and should be recorded to the nearest foot or meter per second.

13.6.6.4 A correction table should be logged based on velocity of sound versus incremental depth. Hydrographic processing software uses this information to develop correction tables to be applied for both single and multibeam system depths. The average velocity of each cast can be calculated and may be used to adjust the depth sounder.

13.7 Datum:

13.7.1 A reference datum should be used to convert measured depths to bottom profile elevations. In most, but not necessarily all cases, the datum will be an accepted national vertical datum. An independent datum is acceptable in cases where connecting the measurement to the national datum is too costly to justify, or where control structures related to the water body are already constructed to a different datum. Converting depths to elevations referenced to the national datum will ensure that measurements can be properly repeated even if control points are destroyed (9).

13.7.2 The vertical control for converting depth measurements is generally determined by measuring the water level in the survey area over the survey time period. The important factor in using a vertical datum is to ensure that all depths are referenced to the same datum elevation (9).

13.8 Interpreting Depth Records:

13.8.1 A correct interpretation of bottom profiles remains a major problem, although echo sounders have been used for many years. A general caution should always be observed: when recorded traces on the graphic or digital record cannot be attributed with reasonable certainty as reflections from the bottom, the traces should not be recorded as soundings. In hydrographic surveys performed for producing navigational charts, it is important that all “stray” or spurious soundings be examined with care and identified as to source, since any unidentified source could present a threat to navigation.

13.8.2 One basic factor to consider when interpreting bottom traces is that a hard bottom will reflect an echo more strongly than a soft bottom. On instruments with sensitivity control, the sensitivity should be set to the minimum position which produces a good, consistent bottom trace.

13.8.3 A relatively flat bottom composed of rock, sand, or consolidated sediments usually will produce a thin, dark trace on an analog chart. Such a bottom will often create multiple echoes in shallow water caused by the signal bouncing back and forth between the bottom and the water surface. The echoes appear as multiples of the actual depth, that is always the most shallow reading on the trace.

13.8.4 A relatively soft bottom composed of unconsolidated silt, clay, or organic materials, or all three, will produce a broad echo trace of light intensity. The broad trace is caused by the reflection of the transmitted signal from both the top of the material and any firmer surfaces of consolidated material beneath the top. The thickness of the fluff or soft layer can sometimes be determined by a split in this type of echo trace on the graphic record.

13.8.5 Another check on the type of bottom is the relative setting of the sensitivity control required to obtain recordings at various depths. The air-water interface generally produces the strongest echoes. Rock, sand, metal, wood, fish, and plankton produce echoes in a diminishing order of intensity.

13.8.6 The width of the bottom trace may also be related to water depth. In deep water soundings, the conical-shaped beam produced by the transducer is reflected from a large area of the bottom resulting in a wide trace. In shallow water, the conical beam is reflected from a smaller area resulting in a narrow trace. For very narrow beam transducers, this difference may be negligible. For wide beam transducers, the difference is large.

13.8.7 Actual bottom profiles cannot always be determined with certainty because echo traces do not always represent actual physical conditions. Correct interpretation of analog or digital depth data is sometimes rendered very difficult by the presence of heavy marine growth, floating objects, bottom projections, or depressions representing sudden bottom changes, or steep bottom slopes. For a more detailed discussion on data interpretation see Ref (2).

13.9 Specific Use of Sonic-Echo Sounders:

13.9.1 *Single Transducer Channel Sweep System*—The most common use of an echo sounder is for charting or mapping the boundary of water bodies. A single transducer, mounted either over the side or within a well in the boat hull, can take a continuous series of depth readings below the survey boat as the boat moves along a given line (see Fig. 10). One pass of the boat provides one line measurement of depth, usually either parallel or perpendicular to the flow direction (3). The depth recorder produces a graphic plot of depth versus time on chart paper designed for the recorder’s printing capabilities (see Fig. 7). With interfacing digital equipment, the depths may either be shown numerically in a digital display, or transferred to a tape or disk for future use.

13.9.2 *Multiple Transducer Channel Sweep Systems (Sonic-Echo Sounding Technique)*:

13.9.2.1 In situations where detection of navigational obstacles is of major concern, multiple transducer channel sweep systems may be employed. These systems utilize arrays of transducers that transmit overlapping acoustic beams, providing complete coverage of the bottom (see Fig. 11). The transducers can be mounted on booms projecting from the side of the survey boat, or they can be mounted on a floating boom pushed by the survey boat. The optimum width of boom depends on operating conditions in a given area. One pass with a channel sweep system equals many passes with a single transducer system, thereby saving many hours of operating time where full coverage is required (see Fig. 10).

13.9.2.2 Data can be displayed either in analog or digital form. Use of digital techniques permits the display of many more transducer signals on one recorder. In addition, the existence of shallow depths in certain areas can be emphasized by automatically

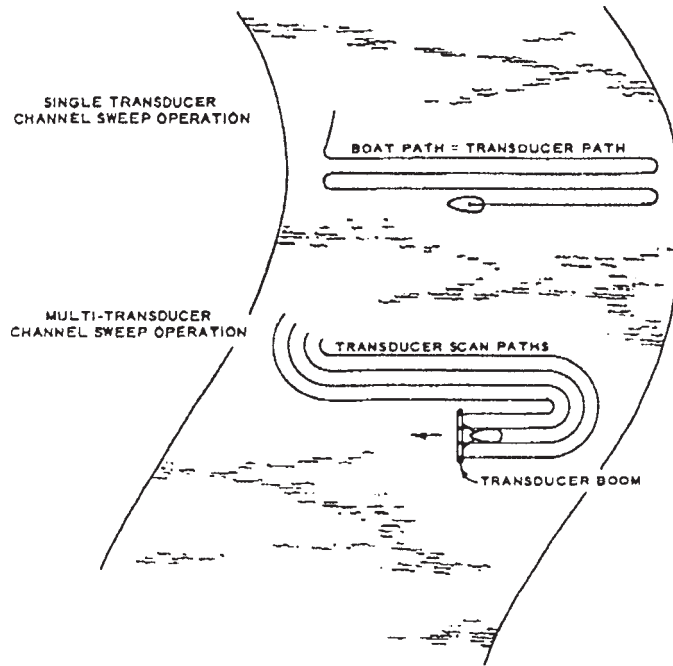

FIG. 10 Single Beam vs. Channel Sweep Acoustical Sounding (3)

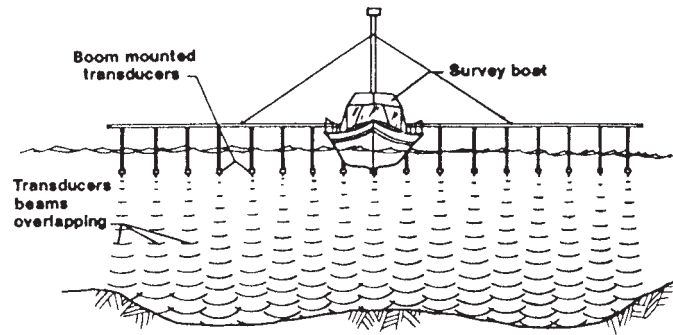

FIG. 11 Channel Sweep System

outlining or shading these critical regions (3).

13.9.3 *Fan-Beam Acoustic Sounding System (Sonic Echo Sounding Technique) or Multibeam Survey Systems*—The path covered by a single transducer depth recorder may also be enlarged by using a fan-beam sounding system. This system contains a number of narrow beam transducers mounted in close proximity, and focused at equally spaced angles under the survey boat (see Fig. 12). Each transducer acts as a separate acoustic-distance measuring unit beamed at a given angle with respect to the bolt-hole

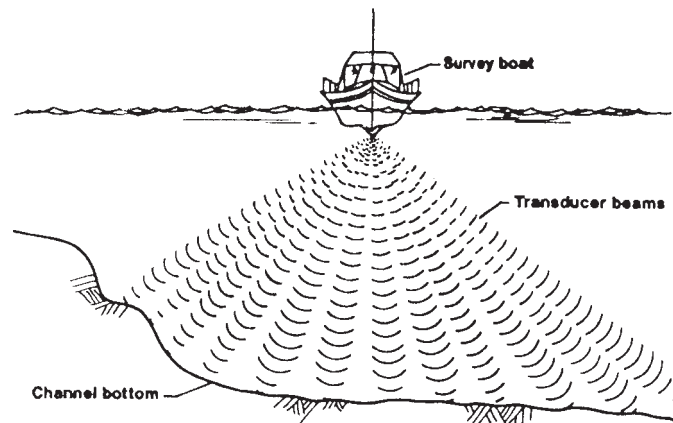

FIG. 12 Fan-beam Acoustic System

vertical. By electronic computation, the depth component for each beam can be derived from the slant-distance signal and a gyro vertical reference signal. Signals ~~are can be~~ displayed on a cathode-ray tube aboard the survey boat in a manner that gives a cross section of the channel perpendicular to the direction of boat travel. Signals ~~are also digitized and recorded on magnetic tape~~ for later ~~automatic~~ data processing (3) (7).

13.9.3.1 Beam spacing is typically designed between 0.5 and 3.0 degrees.

13.9.3.2 Horizontal positioning accuracy for depths are dependent on the hydrographic system to compensate for errors caused by survey vessel roll, pitch, and yaw requiring accurate motion compensation instrument measurements.

13.9.3.3 Velocity meter data is extremely critical since velocity variations can refract the outer beams. The processing software provides sound velocity tables to correct for these conditions. Improper and inadequate sound velocity profiles can render the multibeam data unusable.

13.9.3.4 Quality control and quality assurance for multibeam system data require extensive field calibration procedures that are absolutely essential to assure a high degree of accuracy, especially for the outer beams. Consult the instrument and software developers and hydrographic survey manuals for proper methods for multibeam system calibration (7).

13.9.4 *Side-Scan Sonar Systems (Sonic Echo Sounding Technique):*

13.9.4.1 Side-scan sonar systems are designed to emit fan shaped patterns of acoustic pulses from a towfish tethered to a survey vessel (see Fig. 13). A set of transducers mounted in a compact towfish generate high-powered, short-duration, acoustic pulses required for very high resolution bottom profiles. The transducers are set in the towfish, declined slightly from the horizontal, causing the pulses to project downward and outward to either side of the fish in a plane perpendicular to its path. The qualitative picture of the bottom provides a means of detecting natural and manmade objects and bottom sediment characteristics. Good acoustic reflectors such as rocks, ledges, metal objects, and sand ripples are represented as darkened areas on the record. Depressions and other features scanned from the acoustic beam are indicated by light areas. An experienced observer can interpret most records at a glance, recognizing not only significant features and objects, but often more difficult data such as the composition and relative hardness of the bottom, and the shape and condition of submerged objects (3).

13.9.4.2 A side-scan sonar system generally consists of a recorder, transceiver, and a towfish containing transducers and pre-amplifier circuitry. The towfish consists of a streamlined, hydrodynamically balanced body about 3 ft (1 m) long containing two sets of transducers that scan the waterway bottom on either side. The high frequency beam is slightly depressed from the horizontal with the vertical axis of the main lobe pointing about 10° downward (see Fig. 13 (b)). The width of the beam is quite narrow in the horizontal plane (2° or less) (see Fig. 13 (a)). The towfish is usually operated at a distance above the bottom equal to 10 to 20 % of the range scale. The nose of the towfish contains the transmitting and receiving circuitry. The transmitter energizes the transducers when a trigger pulse is received from the shipboard recorder. The receiving circuitry amplifies the received echos and relays them through the tow cable to the recorder (3).

13.10 *Seismic (Subbottom) Reflection (Sonic Echo Sounding Technique):*

13.10.1 Continuous seismic-reflection profiling systems have made it possible to study the structures of rock and sediments beneath the bottom surface of water bodies including oceans, estuaries, lakes, and rivers. Because of its ability to penetrate surface materials on the bottom, the technique is sometimes referred to as subbottom profiling (10).

13.10.1.1 The technique requires a vessel with either a hull-mounted or towed device that emits a sonic pulse at regular intervals as the vessel travels along a selected course or survey track (see Fig. 14). The sonic pulse strikes the bottom and a portion of the

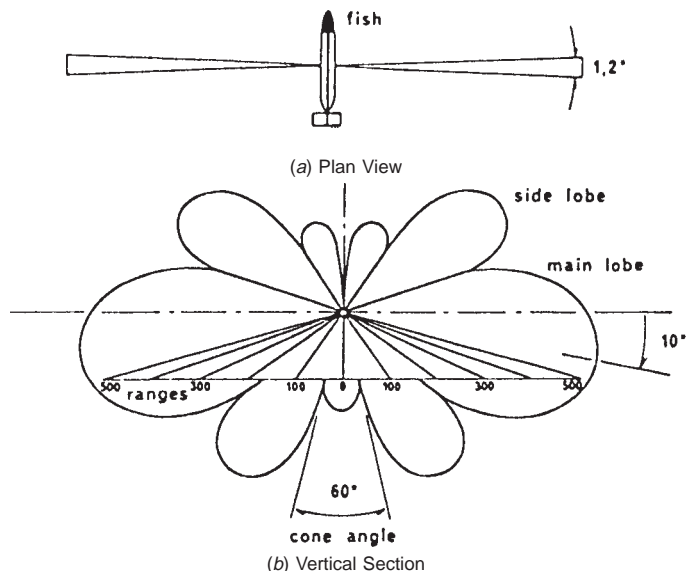

FIG. 13 Towfish Tethered to Survey Vessel Producing Lobe-figure of Side Scan Sonar Beam (14)

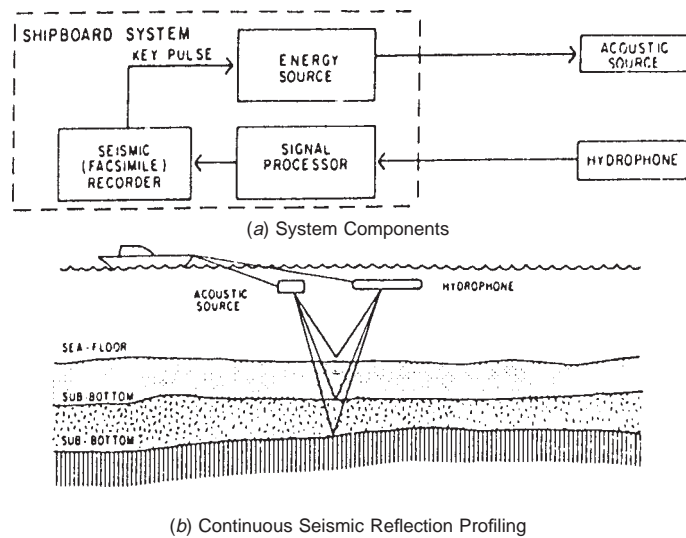

FIG. 14 Seismic Reflection of Bottom (10)

energy is reflected back (return echo) to the surface where it is received by a hydrophone streamer. The hydrophone converts the pressure pulse to an electronic signal that is sent back to a shipboard preamplifier/filter unit where it is processed. The signal then goes to a chart recorder where it is displayed as a dark mark on the chart. The distance from the beginning edge of the chart paper (time 0) to the mark on the chart represent the water depth. As the sonic pulse continues into the bottom sediment, a portion of its energy is reflected back whenever a difference in sediment composition or density is encountered. A greater contrast in material will reflect greater energy and consequently a stronger return echo. These subbottom echoes are received and processed in the same manner as the leading (bottom) echo. When the writing stylus on the recorder completes its travel, and returns to the beginning edge of the chart, the cycle is repeated. This display is an acoustical image of the bottom surface and subbottom structure along the survey track. The depth of penetration into the subbottom is directly related to the characteristics of the profiling system and to the physical and environmental parameters of the water and sediment column (10).

13.10.1.2 A variety of seismic profiling systems are available. The four most commonly used are the tuned transducer, the boomer, the sparker, and the air gun. The names indicate the acoustic source employed by the systems. The typical pulse length, general range of penetration, and resolution that may be achieved by these systems are shown in Fig. 15. As shown, the greatest penetration is achieved by low frequency sound sources. The disadvantage of low frequency sources is that they tend to be very large, with an inherent inefficiency that requires large and expensive power sources for operation (10).

13.10.2 A tuned transducer is made up of piezoelectric crystalline materials formed into various shapes and placed into a mechanically rugged housing. When the material is subjected to an electrical signal it is deformed, thus creating a pressure pulse. Conversely, when the same material is deformed by a pressure wave, it generates an electrical signal. The transducer is therefore capable of emitting and receiving acoustic signals at the frequency for which it was designed and constructed. Other important characteristics that depend on design are the conversion efficiency, the power handling capability, and the beam width of the transducer (10).

13.10.2.1 A variety of subbottom systems are available using the tuned transducer. They have frequencies that vary from 0.40 to 14 kHz. Resolution varies directly with frequency from about 0.5 to 3 ft (0.15 to 0.91 m). Depth of penetration is inversely proportional to frequency. The penetration depth also decreases as sediment particle size and density increase. Subbottom penetration has been recorded for depths well over 200 ft (61 m). Fig. 16 shows an example of a tuned transducer system (10).

13.10.2.2 Transducer mounting configurations may be either within a well that is constructed in the hull of the vessel, in an over-the-side transducer array, in a towed fish array, or on catamaran-type float normally towed on the surface behind the survey vessel.

13.10.3 The boomer can be considered a displacement type device because the acoustic signal is produced by the sudden movement of a flat, circular plate against the water surface (see Fig. 17). The acoustic signatures produced by the plate displacing the water beneath it is of short duration and relatively high amplitude, having a band width of 0.40 to 4.0 kHz.

13.10.3.1 A boomer device is usually mounted on a catamaran that is towed astern or alongside the survey vessel. Because of the limitations this places on the speed of the vessel, and the wave-like distortions that may be transferred to the bottom and subbottom reflections, the units are sometimes towed beneath the surface, or installed inside the hull.

13.10.3.2 Because of the amplitude and frequency characteristics of the boomer, good bottom records can be obtained in sand, gravel, or glacial deposits that are acoustically opaque to a tuned transducer (10).

13.10.4 The sparker is a relatively simple acoustic device with regard to its power supply and transducer design (see Fig. 18). When the power supply is keyed by the seismic recorder, stored electrical energy is discharged to the transducer. Because the discharge is forced to pass through water to the transducer ground return, the heat causes the water to suddenly vaporize into steam

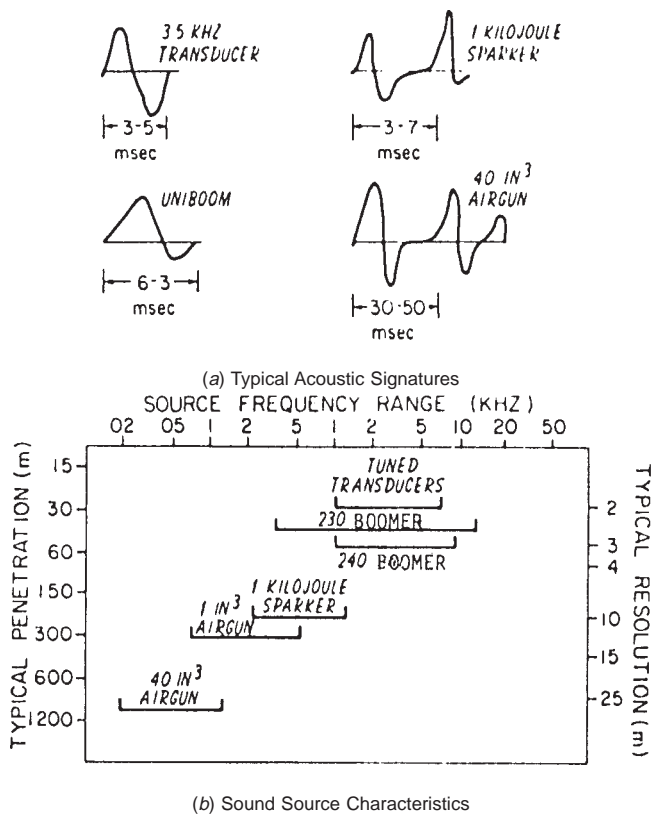

FIG. 15 Acoustic Signature and Relative Effect of Sound Sources (10)

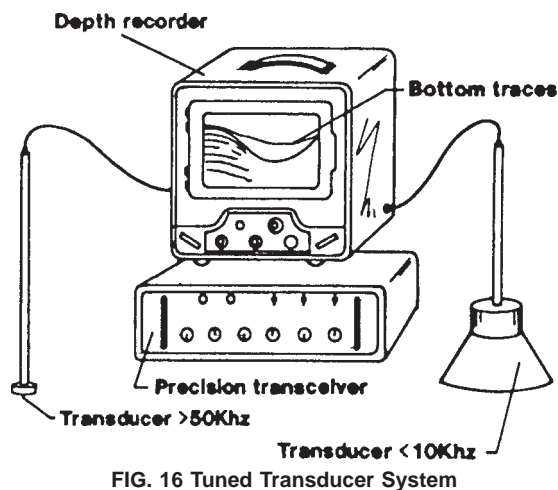

FIG. 16 Tuned Transducer System

and ionized particles. This rapid vaporization produces the initial acoustic pulse. A second acoustic pulse is produced as the steam bubble cools and eventually collapses.

13.10.4.1 A sparker system is capable of fair resolution, 15 to 30 ft (4.6 to 9.1 m), and good penetration, 650 to 1000 ft (198 to 305 m). It is particularly applicable in continental shelf regions where good penetration in hard sands and semi-consolidated material is required (10).

13.10.5 The air gun provides a pneumatic acoustic sound source. The sound production system (see Fig. 19) consists of an onboard air compressor and storage bottle, a shipboard electrical firing circuit controlled by the seismic recorder, and one or more air guns towed behind the survey vessel. When triggered from the seismic recorder, an air gun releases a specified volume of compressed air into the water. This sudden release of air into the water produces a steep-front shock wave followed by several oscillations caused by the repeated contraction and expansion of the air bubble.

13.10.5.1 Air gun systems have poor resolution, 50 to 100 ft (15.2 to 30.4 m) relative to previously discussed acoustic sources.

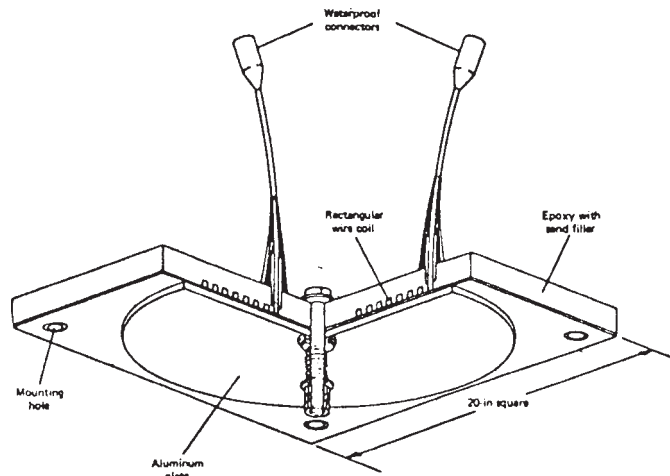

FIG. 17 Boomer Electrical-mechanical Transducer (10)

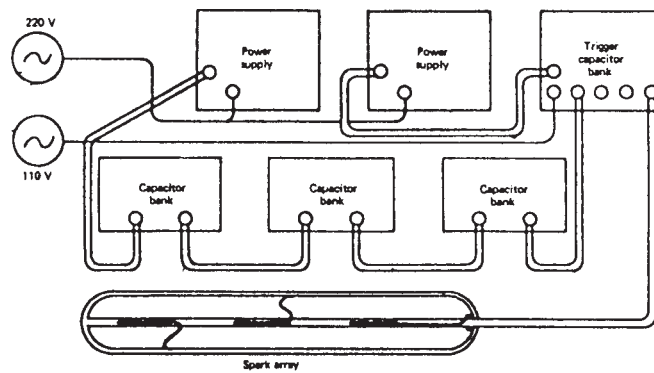

FIG. 18 The Sparker Array

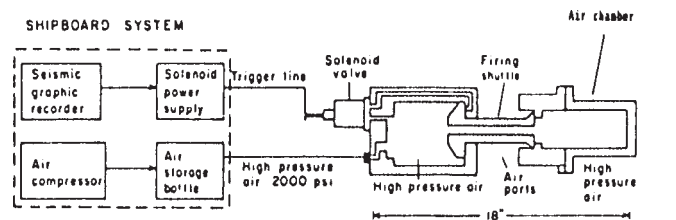

FIG. 19 Components of the Air Gun System (10)

However, large penetration depths, 650 to 6500 ft (18 to 1981 m) can be achieved by the use of large air guns or air gun arrays (10).

PROCEDURE C—ELECTRONIC NONACOUSTIC MEASUREMENT

14. Scope

14.1 This practice is applicable to the measurement of water depth by electronic nonacoustic techniques including ground-penetrating radar and air-borne laser equipment.

14.2 These techniques are still in the process of development for surface water applications. Certain techniques and equipment are not available for public use.

15. Ground-Penetrating Radar (GPR) (Sonic Nonacoustic Technique)

15.1 Ground-penetrating radar (GPR) is an impulse radar system primarily designed as a reconnaissance tool for shallow subsurface site investigations. A special application of the system has been the profiling of the thickness of freshwater and sea ice as well as water depth and ground surface beneath ice cover. The system functions by radiating short electromagnetic pulses into the ice or ground from a transmitting antenna. The transmitted pulse consists of a spectrum of frequencies that are distributed

around the central frequency of the antenna. As the pulse strikes an interface separating layers of different electrical properties, a portion of the pulse energy is reflected back to a receiving antenna. The receiving unit amplifies the reflected energy and converts it into a similarly shaped wave form in the audio frequency range. These processed waveforms are then displayed on a graphic recorder, or recorded on tape for future playback or recording. When displayed on a graphic recorder, a variable gray scale is employed, the strong reflections displayed as black images and the intermediate, weaker reflections in various shades of gray (11). Fig. 20 shows a radar section and interpretation of an ice bridge across the Yukon River obtained with a 10 ns impulse antenna (12).

15.2 The components of a GPR system may consist of a control unit with a microprocessor, a power distribution unit, a graphic recorder, a tape recorder, and a variety of antennas for transmitting and receiving. The lower frequency antennas (80 to 120 MHz) have greater powers of radiation, and longer pulse width, and therefore, emit signals that are less rapidly attenuated by earthen materials than the signals emitted from higher frequency antennas. Therefore, lower frequency antennas can penetrate to greater depths. However, when depth of penetration is not a critical factor, the higher frequency antennas (300 to 500 MHz) produce better resolution of subsurface features (13).

15.3 Radar profiling of a water body through ice cover is possible, given the appropriate physical conditions of the medium and a proven method of calibrating the instruments. The present state of the art requires an experienced operator and observer to produce accurate bottom profiles.

16.

17. Keywords

17.1 depth measurement; echo sounder; profile; sounding; transducer

REFERENCES

- (1) Rantz, S. E., *et al.*, "Measurement and Computation of Streamflow: Volume 1, Measurement of Stage and Discharge," U.S. Geological Survey Water Supply Paper 2175, 1982.
- (2) *Hydrographic Manual*, Fourth Edition, National Oceanic and Atmospheric Administration, Washington, DC, 1976.
- (3) *Measurement of Hydrographic Parameters in Large Sand-Bed Streams from Boats*, Task Committee on Hydrographic Investigations of the Committee on Waterways of the Waterway, Port, Coastal, and Ocean Division, 1983, American Society of Civil Engineers, New York, NY 10017.
- (4) *National Engineering Handbook*, Section 3, Chapter 7, U.S. Department of Agriculture, Soil Conservation Service, pp. 1-31.
- (5) Davis, Foote, and Kelley, *Surveying-Theory and Practice*, Fifth Edition, 1966, Chapter 30, McGraw Hill, New York, NY.
- (6) Keen, B. L., "A New Generation Portable Echo Sounder," *Proceedings, U.S. Army Corps of Engineers Surveying Requirements Meeting*, Feb. 2-5, 1982, U.S. Army Waterways Experiment Station, CE, Vicksburg, MS, April 1982.

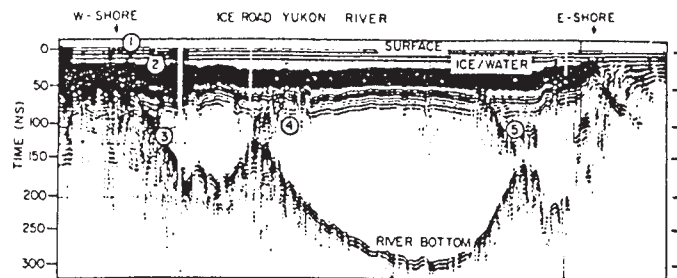

(a) Radar Section of the Ice Bridge Across the Yukon River

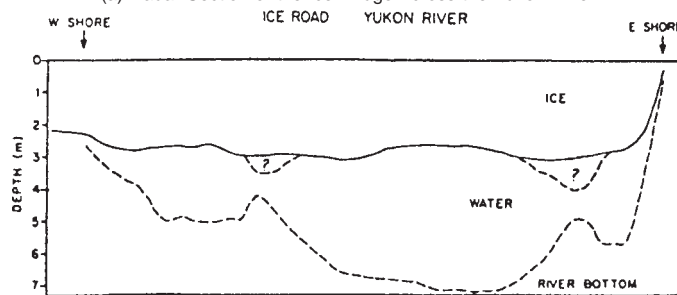

(b) Interpretation of the Radar Section

NOTE 1—Reproduced with the permission of the Minister of Supply and Services Canada, 1990.

FIG. 20 Interpretation of Ground-penetrating Radar Sections (12)



- (7) Hart, E. D., and Downing, G. C., "Positioning Techniques and Equipment for *Hydrographic Surveying*, Engineering Manual EM 1110-2-1003, U.S. Army Corps of Engineers Hydrographic Surveys," *TR H-77-10*, U.S. Army Engineer Waterways Experiment Station, CE, Vicksburg, MS, May 1977—Engineers, 2001.
- (8) Blanton, James, III, "Procedures for Monitoring Reservoir Sedimentation," *U.S. Bureau of Reclamation Technical Guideline*, October 1982.
- (9) Davis, R. E., Foote, F. S., Anderson, J. M., and Mikhail, E. M., *Surveying-Theory and Practice*, Sixth Edition, 1981, Chapter 21, McGraw Hill, New York, NY.
- (10) Sylvester, R. E., "Single Channel, High-Resolution Seismic-Reflection Profiling: A Review of the Fundamentals and Instrumentation," *Handbook of Geophysical Exploration at Sea*, Geyer, R. A. ed., CRC Press, Boca Raton, FL, 1983.
- (11) *Soil Science Society of America Journal*, Soil Science of America, Vol 49, No. 6, November–December 1985, pp. 1490–1498.
- (12) Annon, A. P., and Davis, J. L., "Impulse Radar Applied to Ice Thickness Measurements and Freshwater Bathymetry," *Energy, Mines, and Resources Canada, Report of Activities, Part B; Geological Survey of Canada, Paper 77-1B*, 1977.
- (13) "Soil Survey Techniques," *SSSA Special Publication No. 20*, Soil Science Society of America, Madison, WI, 1987.
- (14) Fleming, B. W., *Side-Scan Sonar: A Comprehensive Presentation*, EG&G Environmental Equipment Division, Waltham, MA, 1980.

ASTM International takes no position respecting the validity of any patent rights asserted in connection with any item mentioned in this standard. Users of this standard are expressly advised that determination of the validity of any such patent rights, and the risk of infringement of such rights, are entirely their own responsibility.

This standard is subject to revision at any time by the responsible technical committee and must be reviewed every five years and if not revised, either reapproved or withdrawn. Your comments are invited either for revision of this standard or for additional standards and should be addressed to ASTM International Headquarters. Your comments will receive careful consideration at a meeting of the responsible technical committee, which you may attend. If you feel that your comments have not received a fair hearing you should make your views known to the ASTM Committee on Standards, at the address shown below.

This standard is copyrighted by ASTM International, 100 Barr Harbor Drive, PO Box C700, West Conshohocken, PA 19428-2959, United States. Individual reprints (single or multiple copies) of this standard may be obtained by contacting ASTM at the above address or at 610-832-9585 (phone), 610-832-9555 (fax), or service@astm.org (e-mail); or through the ASTM website (www.astm.org).