



Designation: D 5129 – 95 (Reapproved 1999)

Standard Test Method for Open Channel Flow Measurement of Water Indirectly by Using Width Contractions¹

This standard is issued under the fixed designation D 5129; the number immediately following the designation indicates the year of original adoption or, in the case of revision, the year of last revision. A number in parentheses indicates the year of last reapproval. A superscript epsilon (ϵ) indicates an editorial change since the last revision or reapproval.

1. Scope

1.1 This test method covers the computation of discharge (the volume rate of flow) of water in open channels or streams using bridges that cause width contractions as metering devices.²

1.2 This test method produces the maximum discharge for one flow event, usually a specific flood. The computed discharge may be used to help define the high-water portion of a stage-discharge relation.

1.3 The values stated in inch-pound units are to be regarded as the standard. The SI units given in parentheses are for information only.

1.4 *This standard does not purport to address all of the safety concerns, if any, associated with its use. It is the responsibility of the user of this standard to establish appropriate safety and health practices and determine the applicability of regulatory limitations prior to use.*

2. Referenced Documents

2.1 ASTM Standards:

- D 1129 Terminology Relating to Water³
- D 2777 Practice for Determination of Precision and Bias of Applicable Methods of Committee D-19 on Water³
- D 3858 Test Method for Open Channel Flow Measurements of Water by Velocity-Area Method³

2.2 ISO Standard:

- ISO 748 Liquid Flow Measurements in Open Channels—Velocity-Area Measurements⁴

3. Terminology

3.1 *Definitions*—For definitions of terms used in this test method, refer to Terminology D 1129.

3.2 Definitions of Terms Specific to This Standard:

3.2.1 *alpha* (α)—a velocity-head coefficient that adjusts the

velocity head computed on basis of the mean velocity to the true velocity head.

3.2.2 *area* (A)—the area of a cross section, parts of a cross section, or parts of bridges below the water surface. Subscripts indicate specific areas as follows:

- A_i = area of subsection i ,
- A_j = area of piers or piles that is submerged,
- A_1 = area of total cross section 1 (see Fig. 1), and
- A_3 = gross area of section 3.

3.2.3 *conveyance*, (K)—a measure of the carrying capacity of a channel cross section, or parts of a cross section, and has units of cubic feet per second or cubic metres per second. Conveyance is computed as follows:

$$K = \frac{*1.486}{n} AR^{2/3}$$

where:

- n = the Manning roughness coefficient,
 - A = the cross-section area, ft²(m²), and
 - R = the hydraulic radius, ft (m).
- *in SI units = 1.0

The following subscripts refer to specific conveyances for parts of a cross section:

- K_a, K_b = conveyances of parts of the approach section to either side of the projected bottom width of the contracted section (see Fig. 2). K_d is always the smaller of the two,
- K_d = conveyance at the upstream end of the dikes,
- K_i = conveyance of subsection i ,
- K_q = conveyance of the part of the approach section corresponding to the projected bottom-width, and
- K_T = total conveyance of cross section.

3.2.4 *depth* (y)—depth of flow at a cross section. Subscripts denote specific cross section depths as follows:

- y_1 = depth of flow in cross section 1 (approach section), and
- y_3 = depth of flow in cross section 3 (contracted section).

3.2.5 *eccentricity* (e)—a measure of the symmetry of the contraction in relation to the approach channel.

¹ This test method is under the jurisdiction of ASTM Committee D-19 on Water and is the direct responsibility of Subcommittee D19.07 on Sediments, Geomorphology, and Open-Channel Flow.

Current edition approved Sept. 10, 1995. Published November 1995. Originally published as D 5129 – 90. Last previous edition D 5129 – 90.

² This test method is similar to methods developed by the U.S. Geological Survey and described in documents referenced in Footnote 5.

³ *Annual Book of ASTM Standards*, Vol 11.01.

⁴ Available from American National Standards Institute, 11 W. 42nd St., 13th Floor, New York, NY 10036.

3.2.6 *friction slope* (S_f)—the energy loss, h_f , divided by the length of the reach, L .

3.2.7 *Froude number* (F)—an index to the state of flow in a channel. In a rectangular channel, the flow is tranquil or subcritical if the Froude number is less than 1.0 and is rapid or supercritical if it is greater than 1.0.

3.2.8 *head* (h)—static or piezometric head above an arbitrary datum. Subscripts indicate specific heads as follows:

h_f = head loss due to friction, and
 h_s = stagnation-surface level at embankment face.

3.2.9 *hydraulic radius* (R)—is equal to the area of a cross section or subsection divided by its wetted perimeter.

3.2.10 *length* (L)—length of bridge abutment in direction of flow. Subscripts or symbols identify other lengths as follows:

L_d = length of dikes,
 L_w = distance from approach section to upstream side of contraction,
 u = length of projection of abutment beyond wingwall junction, and
 x = horizontal distance from the intersection of the abutment and embankment slopes to the location on upstream embankment having the same elevation as the water surface at section 1.

3.2.11 *wetted perimeter* (P)—is the sum of the hypotenuse of a right triangle defined by the distance between adjacent stations of the cross section and the difference in bed elevations.

3.2.12 *width* (b)—width of contracted flow section. Subscripts denote specific widths as follows:

b_d = offset distance for straight dikes, and
 b_t = width of contracted flow section at water surface.

3.3 *Symbols: Symbols:*

3.3.1 flow contraction ratio = m .

3.3.2 *coefficients*—

C = coefficient of discharge,
 C' = coefficient of discharge for base condition,
 n = Manning roughness coefficient, and
 k = discharge coefficient adjustment.

4. Summary of Test Method

4.1 The contraction of a stream channel by a bridge creates an abrupt drop in water-surface elevation between an approach section and the contracted section under the bridge that can be related to the discharge using the bridge as a metering device. A field survey is made to determine distances between and elevations of high-water marks upstream and downstream from the contraction and the geometry of the bridge structure. These data are used to compute the fall in the water surface between an approach section and the contracted section and selected properties of the sections. This information is used along with discharge coefficients, determined by extensive hydraulic laboratory investigations and verified at field sites, in a discharge equation to compute the discharge, Q .

5. Significance and Use

5.1 This test method is particularly useful to determine the discharge when it cannot be measured directly by some type of current meter to obtain velocities and with sounding weights to determine the cross section.

5.2 Even under the best conditions, the personnel available cannot cover all points of interest during a major flood. The engineer or technician cannot always obtain reliable results by direct methods if the stage is rising or falling very rapidly, if flowing ice or debris interferes with depth or velocity measurements, or if the cross section of an alluvial channel is scouring or filling significantly.

5.3 Under the worst conditions, access roads are blocked, cableways and bridges may be washed out, and knowledge of the flood frequently comes too late. Therefore, some type of indirect measurement is necessary. The contracted-opening method is commonly used on valley-floor streams.

6. Apparatus

6.1 The equipment generally used for a “transit-stadia” survey is recommended. An engineer’s transit, a self-leveling level with azimuth circle, newer equipment using electronic circuitry, or other advanced surveying instruments may be used. Standard level rods, a telescoping, 25-ft (7.62 m) level rod, rod levels, hand levels, steel and metallic tapes, tag lines (small wires with markers fixed at known spacings), vividly colored flagging, survey stakes, a camera, and ample note paper are necessary items.

6.2 Additional equipment that may expedite a survey includes axes, shovels, a portable drafting machine, a boat with oars and motor, hip boots, waders, nails, sounding equipment, two-way radios, ladder, and rope.

6.3 Safety equipment should include life jackets, first aid kit, drinking water, and pocket knives.

7. Sampling

7.1 Sampling as defined in Terminology D 1129 is not applicable in this test method.

8. Calibration

8.1 The surveying instruments, transit, etc., should have their adjustment checked, possibly daily when in continuous use or after some occurrence that may have affected the adjustment.

8.2 The standard check is the “two-peg” or “double-peg” test. If the error is over 0.03 ft in 100 ft (0.091 m in 30.48 m), the instrument should be adjusted. The two-peg test and how to adjust the instrument are described in many surveying textbooks. Refer to manufacturers’ manual for the electronic instruments.

8.3 If the “reciprocal leveling” technique is used in the survey, it is the equivalent of the two-peg test between each of two successive hubs.

8.4 Sectional and telescoping level rods should be checked visually at frequent intervals to be sure sections are not separated. A proper fit at each joint can be checked by measurements across the joint with a steel tape.

8.5 All field notes of the transit-stadia survey should be checked before proceeding with the computations.

9. Procedure

9.1 To obtain reliable results, the site selected should be one where the geometry of the bridge is close to one of the standard types or modified types described in Section 11. If a desirable site cannot be found, other methods, such as the slope-area method, may yield better results.

9.1.1 The channel under the bridge should be relatively stable. Because the amount of scour at the time of the peak flow cannot be determined, do not use this test method at contractions on sand channels. Avoid contractions where large scour holes have formed because the coefficients presented herein do not apply.

9.1.2 The fall, Δh , is the difference in the computed water surface elevation, between sections 1 and 3, and is not to be less than 0.5 ft (0.15 m). It is defined by high-water marks.

9.1.3 The fall should be at least four times the friction loss between sections 1 and 3. Therefore, avoid long bridges downstream from heavily wooded flood plains.

9.2 The approach section, section 1, is a cross section of the natural, unconfined channel upstream from the beginning of drawdown. Locate section 1 one bridge-opening width, b , upstream from the contraction to be sure it is upstream from the drawdown zone. For a completely eccentric contraction, one with no contraction on one bank, locate section 1 two bridge-opening widths upstream because such a contraction is considered as half a normal contraction. Section 1 includes the entire width of the valley perpendicular to the direction of flow.

9.2.1 When water-surface profiles are level for some distance along the embankment or upstream from the contraction, ponded approach conditions may exist. Even so, survey an approach section because under some conditions, the approach velocity head just balances the friction loss.

9.3 The contracted section, section 3, is the minimum area on a line parallel to the contraction. Generally, the section is between the abutments. When abutments of a skewed bridge are parallel to the flow, section 3 is still surveyed parallel to the contraction even though the minimum section is actually perpendicular to the abutments. An angularity factor (see 13.3.1) adjusts the surveyed section to the minimum section.

9.3.1 The area, A_3 , is always the gross area of the section below the level of the free water surface. No deductions are made for areas occupied by piles, piers, or submerged parts of the bridge if they lie in the plane of the contracted section.

9.3.2 The mean velocity, V_3 , is computed using the gross area, A_3 .

9.3.3 The conveyance, K_3 , is computed with the area of piles, piers, or submerged parts deducted from the gross area.

9.3.4 The wetted perimeter used to compute the hydraulic radius, R , will include the lengths of the sides of the piles, piers, or bridge surfaces in contact with the water.

9.4 Water-surface levels for sections 1 and 3 must be determined as described below; otherwise, the discharge coefficients will not be applicable.

9.4.1 At section 1, develop a profile on each bank near the ends of the section from high-water marks in the vicinity. If there are not marks in these areas and a large degree of

contraction exists, draw a profile of marks along the upstream face of the embankment. If this profile is level for much of the distance along the embankment, assume this elevation is the same as that of section 1.

9.4.2 For section 3, obtain water-surface elevations along the downstream side of the embankment adjacent to the abutments regardless of the location of section 3.

9.4.3 Compute water-surface elevations at sections 1 and 3 as the average of the elevations on each bank.

9.4.4 The one exception is an opening with a high degree of eccentricity. In this area, determine the elevation of section 3 from marks on the contracted side only and use this elevation to compute both the area of section 3 and fall between sections 1 and 3.

9.5 Complete details of the bridge geometry should be obtained so that both plan and elevation drawings can be made. Determine wingwall angles and lengths, lengths of abutments, position and slopes of the embankments and abutments, elevation of roadway, top width of embankment, details of piers or piles, and elevations of the bottom of girders or beams spanning the contraction. Use a steel tape for most lineal measurements rather than scaling distances from a plan. Pictures of the upstream corners of both abutments should be taken. Note which of the four types of contractions the constriction is.

10. Basic Computations

10.1 The drop in water-surface level between an upstream section and a contracted section is related to the corresponding change in velocity. The discharge equation results from writing the energy and continuity equations for the reach between these two sections, designated as sections 1 and 3 in Fig. 1.

$$Q = CA_3 \sqrt{2g \left(\Delta h + \alpha_1 \frac{V_1^2}{2g} - h_f \right)} \quad (1)$$

where:

Q = discharge,

C = coefficient of discharge,

A_3 = gross area of section 3, this is the minimum section between the abutments and is not necessarily at the downstream side of the bridge,

Δh = difference in elevation of the water surface between sections 1 and 3,

$\alpha_1 V_1^2 / 2g$ = weighted average velocity head at 1,

V_1 = average velocity, Q/A_1 , and

h_f = head loss due to friction between sections 1 and 3.

10.2 The velocity head at section 1 is expressed by the term:

$$\frac{\alpha_1 V_1^2}{2g}$$

where:

$V_1 = Q/A_1$ and α_1 is the velocity head adjustment factor.

10.2.1 The value of α is computed from the relative conveyances and areas of the subsections into which a cross

section is normally subdivided to the conveyance and area of the entire section.

$$\alpha = \frac{\sum \frac{K_i^3}{A_i^2}}{\frac{K_T^3}{A_T^2}} \quad (2)$$

where:

i = the subsections, and
 T = the total cross section.

10.3 The friction loss in the discharge equation is the loss between sections 1 and 3. The distance between the two sections is divided into the reach from section 1 to the upstream side of the bridge opening and into the bridge-opening reach. The conveyance at the upstream side of the bridge opening is assumed to be the same as at section 3. The total head loss due to friction is computed as:

$$h_f = L_w \frac{Q^2}{K_1 K_3} + L \left(\frac{Q}{K_3} \right)^2 \quad (3)$$

where:

L_w = the length of the approach reach,
 L = the length of the bridge opening, and
 K_1 and K_3 = the total conveyances of sections 1 and 3.

10.3.1 Satisfactory results cannot be obtained by the contraction method if h_f is large relative to the difference in head, Δh .

10.4 The contracted opening method assumes tranquil flow at section 3. In a prismatic channel the flow is tranquil if the Froude number, F , is less than 1.0. In irregular sections, the Froude number is not an exact index of the state of flow. Therefore, if the computed Froude number exceeds 0.8, the computed discharge may not be reliable.

$$F = \frac{V_3}{\sqrt{g y_3}}$$

where:

y_3 = the average depth at section 3; $y_3 = A^3/b$.

11. Classifications of Contractions

11.1 The discharge coefficient is a function of the bridge geometry. Most bridge openings can be classified as one of four types representing the distinctive features of their major geometric forms. Laboratory studies have defined certain ratios for each type of contraction and their effect on the discharge coefficient.

11.2 *Type 1*—A Type 1 contraction as shown in Fig. 3 has vertical embankments and vertical abutments with or without wingwalls. The entrance rounding or the wingwall angle, the angularity of the contraction with respect to the direction of flow, and the Froude number affect the discharge coefficient.

11.3 *Type 2*—A Type 2 contraction as shown in Fig. 4 has sloping embankments and vertical abutments. The depth of water at the abutments and the angularity of the contraction with respect to the direction of flow affect the discharge coefficient.

11.4 *Type 3*—A Type 3 contraction as shown in Fig. 5 has sloping embankments and sloping spill-through abutments. The entrance geometry and the angularity of the contraction

with respect to the direction of flow affect the discharge coefficient.

11.5 *Type 4*—A Type 4 contraction as shown in Fig. 6 has sloping embankments, vertical abutments, and wingwalls. The wingwall angle, the angularity of the contraction with respect to the direction of flow, and, for some embankment slopes, the Froude number, affect the discharge coefficient. Notes that the addition of wingwalls does not necessarily make a Type 4 contraction. A Type 1 contraction may have wingwalls. If the flow passes around a vertical edge at the upstream corner of the wingwall, the contraction is Type 1; if the flow passes around a sloping edge at the top of the wingwall, the contraction is Type 4.

11.6 Modified Types:

11.6.1 *Spur Dikes*—Spur dikes are added to some bridge abutments to modify the flow pattern and reduce scour at the abutments. The effects of elliptical and straight dikes on the discharge coefficient have been defined by laboratory study.

11.6.2 *Dual Bridges*—The construction of divided highways has introduced dual-lane bridges. For the special case where the abutments are continuous between the two bridges, the geometry may still be classified as one of the standard types. Discharge coefficients have not been defined for dual bridges without continuous abutments.

11.6.3 *Abutments Parallel to Flow*—The base discharge coefficients for all four types of contractions were determined for abutments perpendicular to the embankment, and then adjusted for angularity or the skew of the embankment. Many newer bridges have embankments at an angle to the channel, but abutments parallel to the flow. The discharge coefficient is the same for both conditions if the angle, ϕ , is less than 20°. The effect of this change in geometry on the discharge coefficient for angles greater than 20° has not been adequately defined and this geometry should not be used in computing peak discharge.

11.6.4 *Nonstandard Types*—Some bridges do not fit any of the four types described. Bridges with Type 1 abutments set on Type 3 embankments, or Type 4 wingwalls with vertical upstream ends for part of their height, or unique construction will require engineering judgment to select the type to be used. When there is a choice between two types, the discharge coefficient can be computed for each type; if the difference is less than 5 %, either type can be selected; if the difference is over 5 %, the two coefficients can be averaged.

11.6.4.1 Arch bridges often approximate a Type 1 contraction; but if much of the arch is submerged a reliable answer will not be obtained by using Type 1 coefficients.

11.6.5 *Combination Sites*—Floods often flow over the road near a bridge in addition to flowing through the bridge opening. This is not a desirable condition for computing peak discharge; but if such a site must be used, a combination of the contraction method and flow-over-embankment method may be used.

11.7 Multiple-Opening Contractions:

11.7.1 Roadway crossings on large streams may include more than one bridge. Procedures for computing peak discharge through multiple-opening contractions have been defined by laboratory study. In general, the procedures used for single openings are applicable, but some of the geometric

ratios and terms in the discharge equation are computed in a different manner.

12. Parameters Affecting the Discharge Coefficient

12.1 The discharge equation (Eq 1), derived from the energy equation and the continuity equation, contains a coefficient, C , that represents a combination of a coefficient of contraction, a coefficient for the eddy losses caused by the contraction, and the velocity-head coefficient, α_3 , for the contracted section.

12.2 Dimensional analysis of the factors that influence the flow pattern through a bridge shows that C can be expressed as a function of certain geometric and flow parameters.

12.2.1 Of the 15 terms evaluated, the only ones that are common to all types of bridge openings are m , L/b , and F . Laboratory studies have shown that, of these, the contraction ratio, m , is the most important, and F has the least general significance. Therefore, m and L/b were selected as primary variables for determining the base discharge coefficient, C' . The other terms are descriptive of the geometric properties of various types of bridge openings. Adjustment factors to the base coefficients have been determined for these terms and the Froude number where applicable.

12.3 The flow-contraction ratio, m , describes the degree of contraction imposed by the constriction on the normal stream channel. The channel-contraction ratio is a measure of the proportion of the total flow that enters the contraction from the sides of the channel. It can be computed from the equation:

$$m = \frac{(Q - q)}{Q} = \frac{1 - 8}{Q}$$

where:

Q = the total discharge, and

q = the discharge that could pass through the opening without contraction.

The total discharge is assumed to be distributed across the approach section in proportion to the conveyances of arbitrarily defined subsections. This assumption can be made because the energy slope is approximately constant across the section.

K_q is the conveyance of the subsection occupied by q , and K_I is the total conveyance of approach section; therefore:

$$m = \frac{1 - K_q}{K_I} = \frac{(K_a + K_b)}{K_I} \quad \text{or} \quad \frac{(K_a + K_b)}{(K_a + K_q + K_b)} \quad (4)$$

13. Determination of the Discharge Coefficient

13.1 One or more steps are required to determine the discharge coefficient. A base coefficient, C' , corresponding to given values of the two primary variables, m and L/b , is determined from one of the base curves of Figs. 7-15 for the type of bridge opening under consideration. The base coefficient, C' , is the final discharge coefficient if all the six or seven standard conditions shown on the base curves are met. The secondary variables given under standard conditions are the only variables to be considered for that particular type of bridge opening.

13.2 *Primary Adjustment Factors*—If the standard conditions are not satisfied, then C' must be adjusted for the effect of each condition that is not standard. These adjustment factors are shown in Figs. 7-17; the product of all adjustment factors and the base coefficients is the discharge coefficient.

13.2.1 Certain combinations of the adjustment factors applied to a base coefficient will yield a value of C greater than 1.00. Because this is impossible, a value of $C = 1.00$ is taken as the maximum under all circumstances. If submergence of both the upstream and downstream bottom chords occurred, the maximum value of the discharge coefficient is the value of the adjustment factor, k_e .

13.2.2 Adjustment factors for the effects of eccentricity, piles or piers, submergence, and skewed embankments with abutments parallel to the flow are applicable to all four types of bridge openings and are discussed in 13.2.3-13.2.5.

13.2.3 The eccentricity, e , of a bridge opening (see Fig. 2) is the ratio of the conveyances K_a/K_b . K_a and K_b are the conveyances of the parts of the approach section to either side of the projected b width, or to either side of the part of the section carrying the discharge, q , that passes through the opening without contraction. K_a is always the smaller of the two. These conveyances are proportional to the flow that has to deviate from its natural course to enter the bridge opening. For ratios greater than 0.12, no correction is necessary for eccentricity. For fully eccentric conditions (see Fig. 16), K_a is zero, therefore $e = K_a/K_b = 0$, and the following procedures should be used:

(1) Locate the approach section, 1, a distance $L_w = 2b$ upstream from the bridge.

(2) Determine the base coefficient, C' , and the adjustment factors by using the ratio $L/2b$. Use abutment on contracted side only to determine C' .

(3) The water-surface elevation at section 1 is average of the elevations at each end of the section.

(4) The downstream elevation is determined on contracted side only (point B). Use this elevation to compute both the area of section 3 and the fall.

13.2.3.1 A fully eccentric contraction is considered as half a normal contraction; therefore the effective bridge width, for computing L_w and C' ; is equal to $2b$. The adjustment factor, k_e , is obtained from the following:

e	0	0.02	0.04	0.06	0.08	0.10	0.12
k_e	0.953	0.966	0.976	0.984	0.990	0.995	1.00

13.2.3.2 Many bridge openings contain piers or piles, and their effect on the discharge coefficient must be evaluated. The total submerged area of the piers or piles projected on the plane defined by section 3 is designated A_j . The ratio of the area of piers or piles to the gross area of section 3, A_j/A_3 , is represented by the letter j . The relation of the channel-contraction ratio m to j determines the adjustment factor, k_j , for piers (see Fig. 17(a)) and the ratios, m , j , and L/b determine k_j for piles (see Fig. 17(b)).

13.2.3.3 The dashed lines on Fig. 17(b) illustrate its use. In this example, enter the right-hand plot at the m value of 0.41; move vertically to an L/b value of 0.69; move horizontally to the line marked $j = 0.10$ in the left-hand plot; then upward to the value of j , 0.04 in this example; and finally move horizontally to the k_j scale on the left to obtain a value of 0.967. For values of j greater than 0.10, move downward from the line marked $j = 0.10$.

13.2.3.4 When both piles or piers and submergence exist, j is computed as the ratio A_j/A_3 . When the upstream and

downstream bridge chords are submerged, A_s is the gross area below the lower bridge chord and A_j is the only area of piles or piers. When only the upstream bridge chord is submerged, A_s equals A_3 , and A_j is only the submerged area of piles or piers.

13.2.4 Many floods cause stages high enough to submerge the lower parts of bridges. The additional wetted perimeter and obstruction of the bridge members affect the flow. The vertical distance between the water level at section 1 and the lowest horizontal member of a partially submerged bridge is designated as t (see Fig. 18). The ratio of t to the sum of y_3 and Δh is called the bridge submergence ratio. Its effect on the discharge coefficient is indicated on Fig. 18 as k_t .

13.2.4.1 Whether the lower bridge members were submerged or not cannot be determined from field evidence under all conditions. Contact with the lower bridge members can be assumed when k_t is less than 1.00. The length of the bottom chord is then added to the wetted perimeter of section 3 even though the downstream bottom chord may not be submerged. The larger wetted perimeter provides a better evaluation of the true friction losses in the approach reach and through the bridge.

13.2.4.2 Where both upstream and downstream bottom chords are submerged and several adjustment factors, including k_t , are used, the discharge coefficient may be nearly 1.00; the maximum value of the discharge coefficient should be the value of k_t from Fig. 18 after all adjustment factors have been applied.

13.2.4.3 Some floods completely submerge the bridge deck. For this condition, the following procedure is suggested to approximate the discharge as follows:

(1) Compute A_3 as the product of b and y_3 minus the cross-sectional area of the submerged bridge.

(2) Use $k_t = 1.00$.

(3) Compute discharge by Eq 1.

(4) This discharge is the total discharge for the width, b , and the flow over the floor of the bridge should not be added to it.

13.2.4.4 For a Type 2 contraction affected by submergence, the depth of water at the toe of each embankment, Y_a and Y_b (see Fig. 4) are measured up to the lower bridge member rather than to the downstream water surface.

13.2.5 When the contraction is at an angle, ϕ , to the flow, the abutments may be parallel to the flow or perpendicular to the embankment. The coefficient for both conditions is the same if the angle ϕ is less than 20° . If the angle is greater than 20° and the abutments are parallel to the flow, an additional correction factor is required. Because this factor has not been adequately defined, do not use a contraction with this geometry to compute peak discharge.

13.3 *Secondary Adjustment Factors*—Other adjustment factors are applicable to one or more types of contractions but not all, or they have a different effect on different types. Adjustment factors for Froude number angularity, entrance rounding, wingwall angle, and depth of water on the abutments are in these categories. Curves for these factors accompany the base coefficient curves for the four types of contractions in Figs. 7-15. Only those factors shown for each type of contraction have a significant effect upon the discharge coefficient.

13.3.1 Angularity should not be confused with eccentricity

(see Fig. 2 and Fig. 16) or curvature of the stream (see Fig. 19). Both the approach section and the contracted section could be perpendicular to the flow in channel on a curve, and no adjustment for angularity is necessary.

13.3.1.1 Angularity may be considered as the relation between the skewed contraction and the flow lines for the unobstructed channel. The adjustment factor, k_ϕ , for angularity is influenced by two independent variables, the channel-contraction ratio, m , and the degree of angularity, ϕ ; but one of these is not necessarily a function of the other.

13.3.1.2 The best interpretation of angularity can be made in the field if it is recognized that the influence of the angle becomes less pronounced with larger channel-contraction ratios. Thus the net direction of flow at the upstream side of the contraction, section 2, does not necessarily determine the angle ϕ , because the flow direction there is also affected by the degree of channel contraction.

13.3.1.3 For other than straight channels and parallel sections, measure the distance, L_w , from section 1 to section 2 from the centroid of the approach section to the middle of section 2. The direction of the chord between these two points is largely independent of the angularity of the contraction. In Fig. 19 no adjustment factor for angularity would be required, but L_w would be measured along a chord at an acute angle to section 2.

13.3.2 For those contractions that have sloping embankments or abutments, curves are presented for at least 1:1 and 2:1 slopes. However, a wide range of slopes is encountered in the field, and coefficients must be computed for other than 1:1 and 2:1 slopes. If the slope is between 1:1 and 2:1, straight-line interpolation is satisfactory.

13.3.3 If the abutment slope differs from the embankment slope, or if the slopes at the ends of the bridge differ, use an average slope. If the two abutments are different types, compute a C' for each side, a and b , and weight the final C with respect to the conveyances, K_a and K_b , as follows:

$$C = \frac{C_a K_a + C_b K_b}{K_a + K_b} \quad (5)$$

13.3.4 The discharge formula cannot be applied directly to all contractions, because laboratory work has not defined base discharge coefficients and adjustment factors for all types of contraction geometry and flow conditions encountered in the field.

13.3.4.1 The discharge coefficient for a bridge opening that cannot be classified exactly as any of the four types described may be estimated by the engineer using his knowledge of the relative effects of the factors that influence the flow pattern and by a reasonable weighting of these factors. The most influential variables generally are m and L/b ; therefore a reasonable estimate of the adjustment factors will give results that are within the range of accuracy expected.

13.4 *Special Conditions*:

13.4.1 Some field conditions, such as other embankment slopes, timber and pile bridges, arch bridges, and spur dikes, do not approximate the conditions tested in the laboratory. Additional tests have provided new adjustment factors or modifications to the original coefficients.

13.4.2 *Other Embankment Slopes*—The laboratory tests

developed coefficients for Types 2, 3, and 4 contractions with 1:1 and 2:1 embankment slopes. Coefficients for a Type 3 contraction with 1½:1 slopes were computed from the original coefficients. Curves for all these conditions are included in this test method. For a Type 4 contraction, use the coefficient for a 2:1 slope for flatter slopes (3:1, 4:1, etc.).

13.4.2.1 For Types 2 and 3 contractions, Fig. 20 illustrates one method of discharge coefficients extrapolation for other slopes. The coefficient for a given embankment slope will be between that for an infinite slope and that for a zero slope. If the slope is infinite, there is no contraction and the coefficient is 1.00. The other limiting slope, 0:1, is for a Type 1, vertical-faced contraction and the coefficient can be computed. Coefficients for 1:1 and 2:1 slopes can be computed, and the four values of coefficients can be plotted as ordinates with the angle of repose, in degrees, as the abscissa. In Fig. 20 the desired coefficient for a 3:1 slope is obtained from a smooth curve through these four points. Note that adjustment factors k_e , k_p , and k_t are not applied when computing the four coefficients; consequently they must be applied to the coefficient obtained from the curve. There will be cases, especially when the Froude number is high, when the four points will not define a smooth curve as shown in Fig. 20. Then, engineering judgment must be used to determine the best method of extrapolation.

13.4.3 *Timber-and-Pile Bridges*—Some bridges have wing-wall and abutment timbers placed on the shoreward side of piles with or without a projection of the abutment timbers upstream from the junction with the wingwall (see Fig. 21). The projecting abutment creates a slightly re-entrant condition at that junction that is not typical of the four types of contractions.

13.4.3.1 Tests of these bridges without the protruding abutment showed the effects of the piles alone. If the high-water elevation at the approach section is higher than the toe of the embankment at the upstream end of the wingwall, use the base coefficient for a Type 4 contraction. If the high-water elevation at the approach section is lower than the toe of the embankment at the upstream end of the wingwall, use an average of Type 2 and Type 4 coefficients.

13.4.3.2 For a timber-and-pile bridge with projecting abutments, determine the base coefficient as explained in 13.4.3.1 and then multiply it by an adjustment factor, k_u . This adjustment factor is a function of the ratio u/b , where u is the length of the projection past the junction with the wingwall (see Fig. 21). Note that b is measured between the streamward sides of the piling, and that the wingwall angle, θ , should be measured as if the wingwall extended from the upstream end of the projecting abutment to the streamward side of the wingwall piling, generally at the pile closest to the toe of the embankment. Values of k_u have been determined for a limited range of u/b as follows:

u/b	k_u
0 to 0.04	0.98
0.05	0.96

13.4.4 *Spur Dikes*—Several types of spur dikes will be encountered in the field. Two common types of earth-embankment dikes are illustrated on Fig. 22. The elliptical dike

is a continuation of the abutment and approximates one quarter of an ellipse. The straight dike may be a continuation of the abutment, or it may be set back a distance, b_d . The straight dike projects normal to the embankment. Adjustment factors have been defined for the addition of these dikes to Type 3 contractions.

13.4.4.1 The elliptical dike is a continuation of the Type 3 abutment, and its geometry is described by the length of the dike, L_d . The adjustment factor, k_d , that accounts for the influence of the dike on the discharge coefficient is a function of the ratio of the length of the dike to the width of the bridge opening, and the channel contraction ratio (see Fig. 23(a)). The addition of elliptical dikes to a constriction with skewed embankments and abutments parallel to the flow further affects the discharge coefficient. An adjustment factor, k_a , is used in addition to k_ϕ to account for this effect. The value of k_a has been defined only for an angle ϕ of 20°. The relation between k_a , L_d/b and m for this angle of skew is shown in Fig. 23(b). Values of k_a may be determined by interpolation between angles of zero and 20°. The discharge coefficient for a constriction with an elliptical dike is thus determined as the product of C' for the Type 3 constriction, the adjustment factors k_ϕ , k_u , k_d , k_a , and other factors for non-standard conditions. The value of x used to determine k_x should be measured on the embankment slope as if the dike were not in place.

13.4.4.2 The geometry of the straight dike is defined by the length of the dike L_d , and the offset distance b_d . The functional relationships that define the adjustment factors k_d and k_b for the straight dike are shown in Fig. 23(c) and 23(d). The discharge coefficient is determined as the product of C' for the Type 3 constriction, the adjustment factors k_ϕ , k_x , k_d , k_b , and the other factors for non-standard conditions. The value of x used to determine k_x should be measured on the embankment slope as if the dike were not in place.

13.4.4.3 For computing discharge through a contraction with spur dikes, the friction loss term is as follows:

$$\left(L + \frac{L_w K_3}{K_f} \right)$$

In the denominator of the discharge, Eq 6 must be changed to include the friction loss due to the addition of the spur dikes. This can be accomplished by changing this term to:

$$L + \frac{L_w K_3^2}{K_f K_d} + \frac{L_d K_3}{K_d}$$

where:

L_d = the length of the dike, and

K_d = the conveyance at the upstream end of the dikes.

13.4.5 *Arch Bridges*—Coefficients for arch bridges were not determined in the laboratory studies made by the U.S. Geological Survey.^{5,6} Most arches have virtually square corners and vertical faces and may be considered similar to Type

⁵ Benson, M. A., and Dalrymple, Tate, "General Field and Office Procedures for Indirect Discharge Measurements," *Techniques of Water Resources Investigations*, Book 3, Chapter , U.S. Geological Survey, 1967.

⁶ Matthai, Howard F., "Measurement of Peak Discharge at Width Contractions by Indirect Methods," *Techniques of Water Resources Investigations* , Book 3, Chapter A4, U.S. Geological Survey, 1984.

1 contraction if the curvilinear part of the arch is not submerged to a large extent. If much of the arch is submerged, a reliable discharge computation cannot be expected by using methods given herein. Culvert methods may be applicable to some arch bridges.

14. Computations

14.1 A direct solution of the discharge equation (Eq 1) is obtained if Q/A_1 is substituted for V_1 and $L_w Q^2/K_1K_3 + L(Q/K_3)^2$ for h_f . Thus:

$$Q = 8.02 CA_3 \times$$

$$\sqrt{\frac{\Delta h}{1 - \alpha C^2 \left(\frac{A_3}{A_1}\right)^2 + 2gC^2 \left(\frac{A_3}{K_3}\right)^2 \left(L + \frac{L_w K_3}{K_1}\right)}} \quad (6)$$

14.2 A step-by-step outline is given as a guide for the computations. See Figs. 24-32.

14.2.1 From the data of the field survey, plot a location sketch, list the high-water marks, plot a high-water profile for each bank, and transverse high-water profiles for upstream and downstream sides of the embankment if these will aid the definition of headwater and tailwater elevations, plot details of abutments and embankments in both plan and elevation, and cross 1 and 3 (see Figs. 24-28).

14.2.2 Determine from high-water profiles the water-surface elevations at sections 1 and 3 as described in 9.4. See 9.4.4 for the special case of eccentric openings. Compute the difference between the average elevation at 1 and the average elevation at section 3. This is the fall, Δh , through the contraction.

14.2.3 The bridge width, b , for short bridges should have been measured in the field. Use this distance or scale it from the plan or the plot of section 3, and lay out an equal length on section 1. The center of the low-water channel should occupy the same relative position to b in sections 1 and 3 (see Fig. 28). The entire b width is used regardless of the angle of skew, ϕ .

14.2.3.1 The length, b , on the approach section should embrace the flow that could pass through the opening without contraction. At sites where there is a winding low-flow channel upstream from the contraction, judgment will be required to lay out the b width in the proper position.

14.2.4 Subdivide the approach section if abrupt changes in the hydraulic radius occur. Subdivision for abrupt changes in roughness are not made unless they occur on the relative shallow overbank parts (see Fig. 28).

14.2.5 List the properties of section 1 (see Fig. 29) and compute the areas and wetted perimeters of each part. Compute the total area.

14.2.6 Compute the conveyance for each subsection (see Fig. 31). Sum the partial conveyances to obtain the total conveyance. Compute α_1 .

14.2.7 Compute the conveyances K_a , K_q and K_b . K_a is always the smaller of K_a and K_b . See Fig. 30.

14.2.8 Compute the contraction ratio, m , as:

$$m = \frac{K_a + K_b}{K_a + K_q + K_b} \quad (7)$$

14.2.9 List the properties of section 3 (see Fig. 31) and compute areas and wetted perimeters. Subdivide the section at the edge of each pier or pile bent and at abrupt changes in hydraulic radius.

14.2.10 Compute the conveyance of each subsection (see Fig. 32). Use net areas in conveyance computations. Even if section 3 is subdivided, α_3 is considered to be 1.00.

14.2.11 Measure and list the slope of the embankment and the abutments (see Fig. 32).

14.2.12 Classify the abutments as to type. If the abutments are different types, the discharge coefficient should be computed for each abutment as explained in 13.3.3. For compound abutments, use judgment in weighting the relative effects of each.

14.2.13 List the value of the items necessary to compute the base discharge coefficient, C' , and any adjustment factors needed.

14.2.14 Find the base curve of the discharge coefficient (see Figs. 7-15) corresponding to the type and slope of the embankments as determined in steps 11 and 12. Obtain the base coefficient, C' , from this curve. Interpolate between the final values of C if the slope is between the slopes for which base curves are shown. For flatter or steeper slopes, see method explained in 13.4.2 and 13.4.2.1.

14.2.15 List (see Fig. 32) the values of the items necessary to compute the ratios shown under "Standard Conditions" for the type of opening under consideration. Compute these ratios.

14.2.16 Determine the adjustment factors, k 's, from the secondary curves. Indicate values of all factors even though they may be 1.00.

14.2.17 Compute C by multiplying C' by the applicable k 's.

14.2.18 Compute the discharge by substituting in the discharge formula (see Fig. 33).

14.2.19 Compute the mean velocities in sections 1 and 3. The reasonableness of these velocities is a rough check on the computed discharge. Compute Froude number for final discharge. It should be less than 0.8 for a valid computation by this method. Show data for drainage area, unit discharge, gage height, and discharge (see Fig. 33).

15. Combination Sites

15.1 Floods often cause flow over the road near the bridge, and approach section properties and most ratios must be computed differently. The following procedure is suggested:

15.1.1 Compute flow over the road, using the entire area of section 1 to calculate the velocity of approach.

15.1.2 Estimate the total discharge and divide section 1 so that the total conveyance is divided in proportion to the discharges through the bridge and over the road. When the flow over the road occurs on both sides of the bridge, divide the approach section into three parts.

15.1.3 Use just that part of section 1 supplying flow to the bridge to compute A_1 , L_w , K_a , K_q , K_b , α_1 , m , and e .

15.1.4 Discharge through the bridge plus that over the road should check estimated discharge within 1%. If it does not, make new estimates until check is obtained.

16. Multiple-Opening Contractions

16.1 A multiple-opening contraction is defined as a series of independent single-opening contractions, all of which freely conduct water from a common approach channel. Independence of the openings is generally indicated when two or more pairs of abutments and one or more interior embankments

exist. Structures in which piers or webs separate several openings between two abutments are considered single-opening contractions.

16.2 To determine the discharge, establish in the approach channel pseudochannel boundaries that divide the flow between openings. This procedure defines a separate approach channel for each individual opening. Take section 1 at a distance one opening width upstream from the embankment in the approach channel defined for each opening. Use the water-surface elevation at that point for h_1 . As shown in Fig. 34, the approach sections to the various openings will not be located on a continuous line across the valley unless the width of all openings is the same. Compute the discharge through each opening, using identical procedures and discharge coefficients given previously for single-opening contractions.

16.2.1 To locate the pseudochannel boundaries between the embankment and the approach section, apportion the length of each embankment between openings in direct proportion to the gross areas, A_3 , of the openings on either side, the large length of embankment being assigned to the larger opening. Then, from the points on the embankment thus determined, project lines upstream parallel to the mean direction of flow. For computation, these lines are assumed to represent the fixed solid upstream boundaries of an equivalent single-opening contraction.

16.2.2 Determine the water-surface level, h_1 , at the location of 1 for each opening. Because high-water marks are commonly found only along the edge of the channel and the embankment, the value of h_1 for the central openings must usually be estimated from high-water marks on the upstream side of the interior embankments. Defining h_s as the maximum water-surface elevation along an interior embankment, the value of h_1 may be determined as:

$$h_1 = h_s - \frac{\alpha_1 Q_1^2}{2gA_1^2} + \frac{Q_1^2 L_w}{3K_1^2} \quad (8)$$

All quantities in the equation are for the pseudo-single-opening channel. The procedure requires the use of an assumed discharge that must be later verified in the computation of discharge.

16.2.3 Determine the downstream water level h_3 as for a single opening the average of water-surface elevations on the downstream side of the embankment on each side of the bridge opening.

17. Precision and Bias

17.1 Determination of the precision and bias for this test method is not possible, both at the multiple and single operator level, due to the high degree of instability of openchannel flow. Both temporal and spatial variability of the boundary and flow conditions do not allow for a consent test method to be used for representative sampling. A minimum bias, measured under ideal conditions, is directly related to the bias of the equipment used and is listed in the following sections. A maximum precision and bias cannot be estimated due to the variability of the sources of potential errors listed in Section 11 and the temporal and spatial variability of open-channel flow. Any estimate of these errors could be very misleading to the user.

17.2 In accordance with Section 1.6 of Practice D 2777, an exemption to the precision and bias statement required by Practice D 2777 was recommended by the Results Advisor and concurred with the Technical Operations section of the D-19 Executive Subcommittee on June 15, 1990.

18. Keywords

18.1 flood; open channel flow; water discharge

APPENDIX

(Nonmandatory Information)

X1. RELATED PUBLICATIONS

X1.1 For additional information relating to the subject of this test method, refer to the following publications:

Lane, E. W., "Experiments on the Flow of Water Through Contractions in Open Channels," *American Society of Civil Engineers Transactions*, Vol 83, 1920.

Kindsvater, C. E., and Carter, R. W., "Tranquil Flow

Through Open-Channel Constrictions," *American Society of Civil Engineers Transactions*, Vol 120, 1955.

Kindsvater, C. E., Carter, R. W., and Tracy, H. J., "Computation of Peak Discharge at Contractions," *U.S. Geological Survey Circular 284*, 1955.

ASTM D 5129

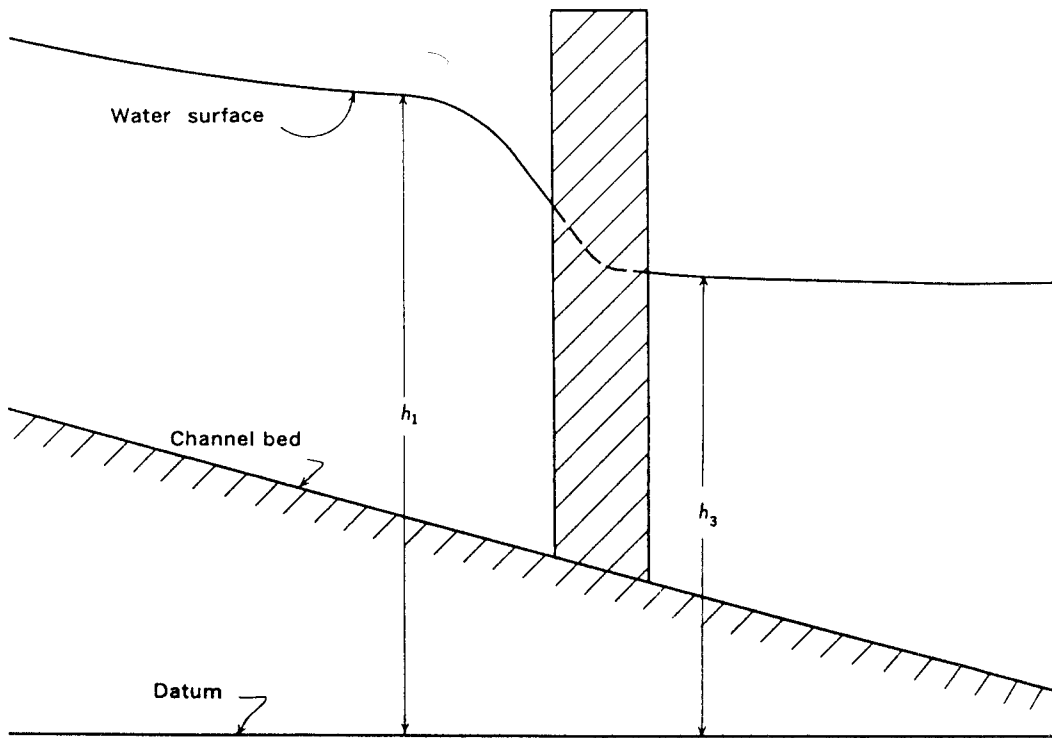
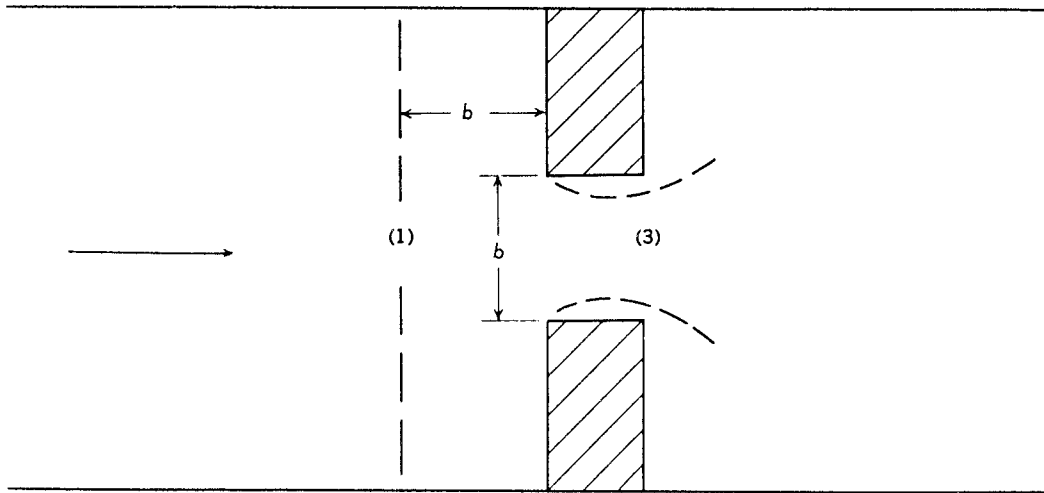

FIG. 1 Definition Sketch of an Open-Channel Contraction

ASTM D 5129

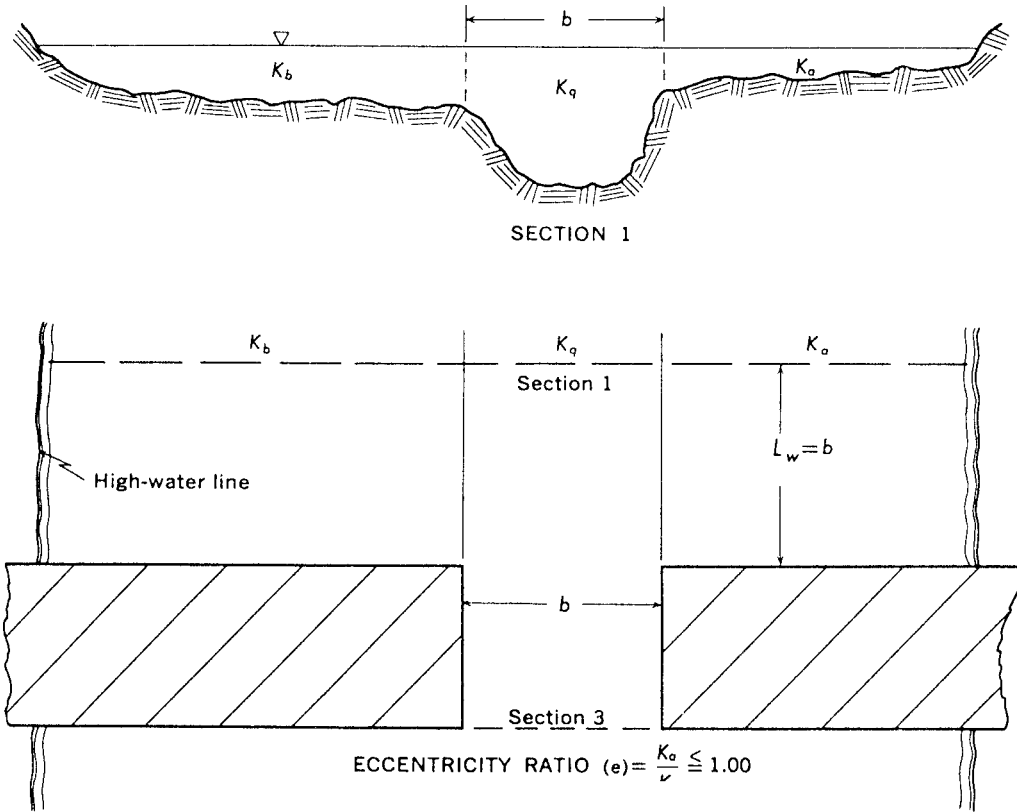

FIG. 2 Definition Sketch of an Eccentric Contraction

ASTM D 5129

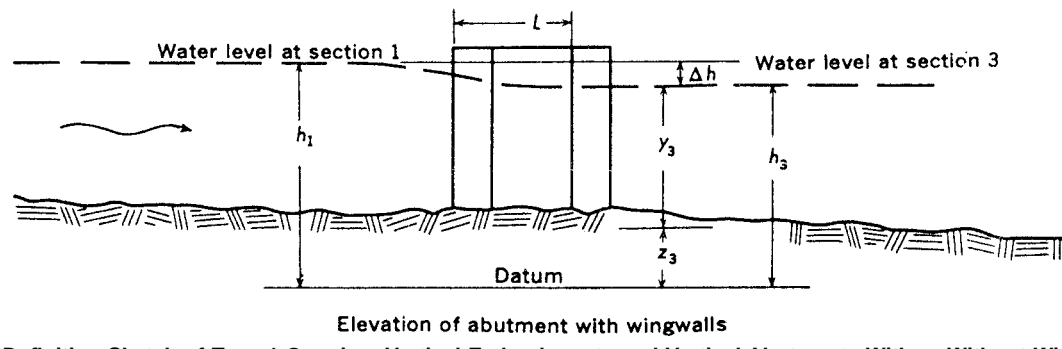
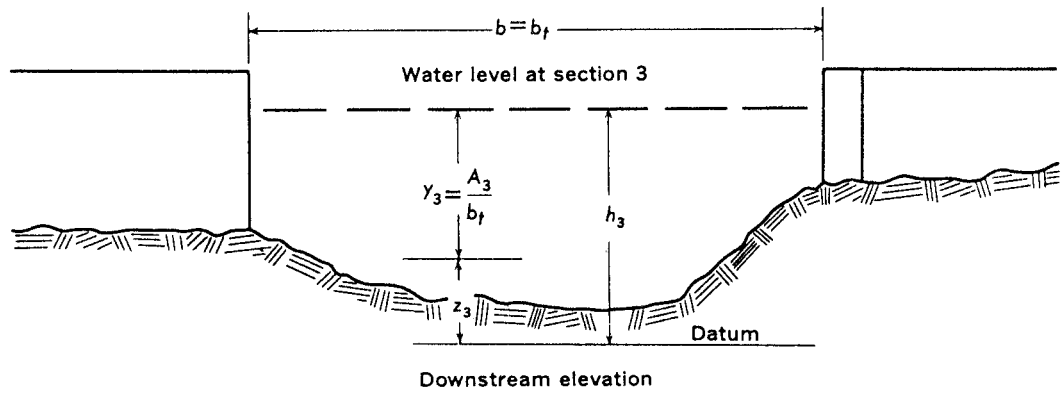
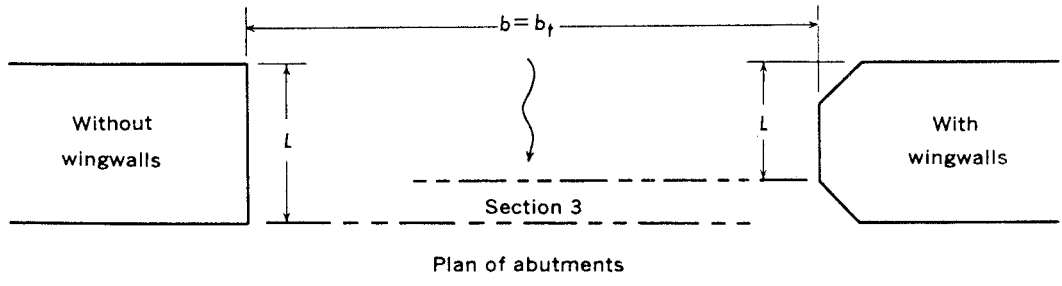

FIG. 3 Definition Sketch of Type 1 Opening, Vertical Embankments and Vertical Abutments With or Without Wingwalls

ASTM D 5129

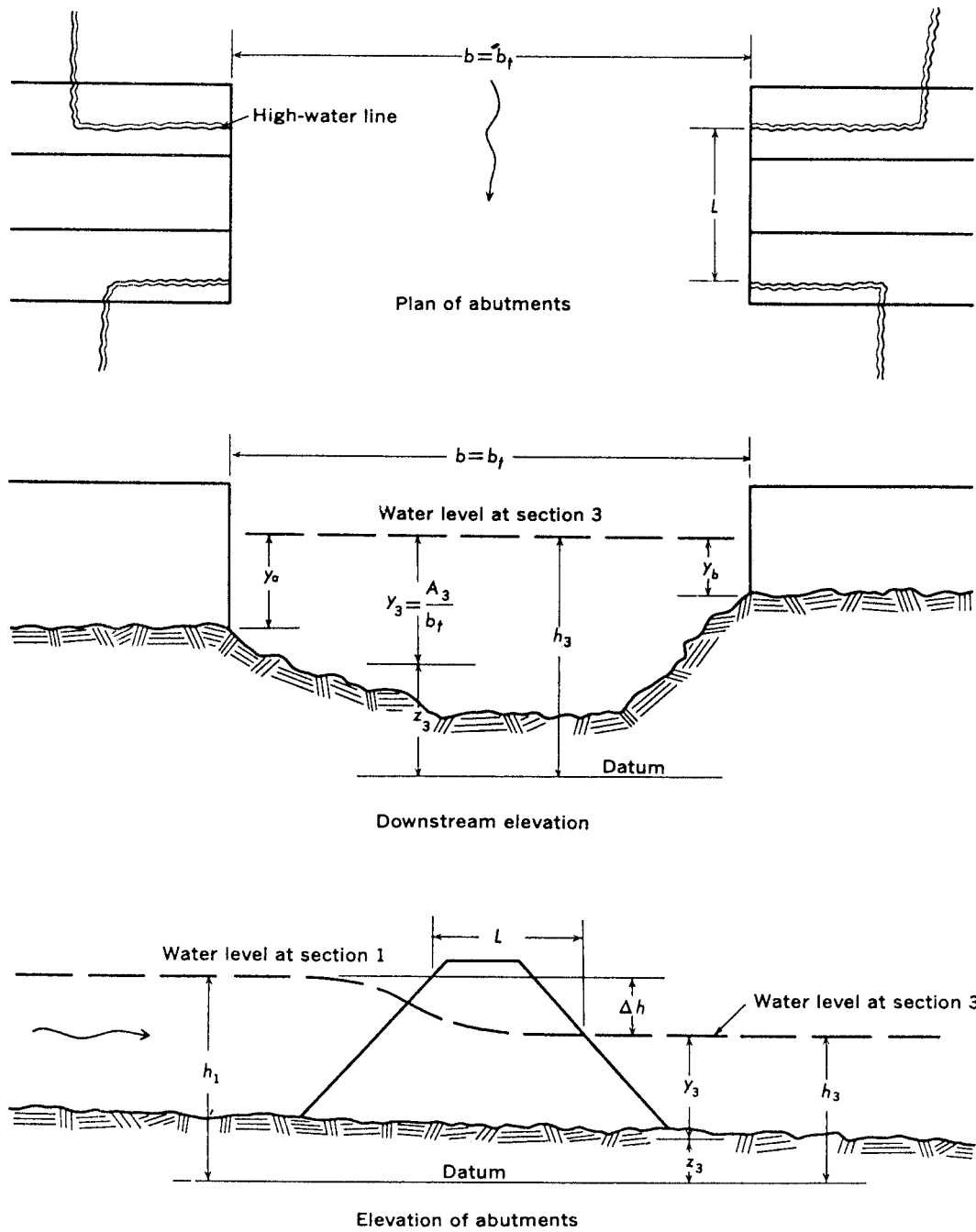

FIG. 4 Definition Sketch of a Type 2 Opening, Sloping Embankments and Vertical Abutments

ASTM D 5129

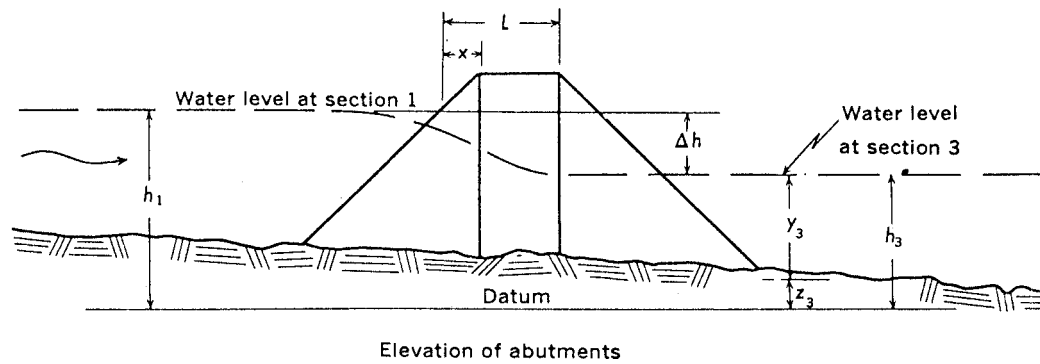
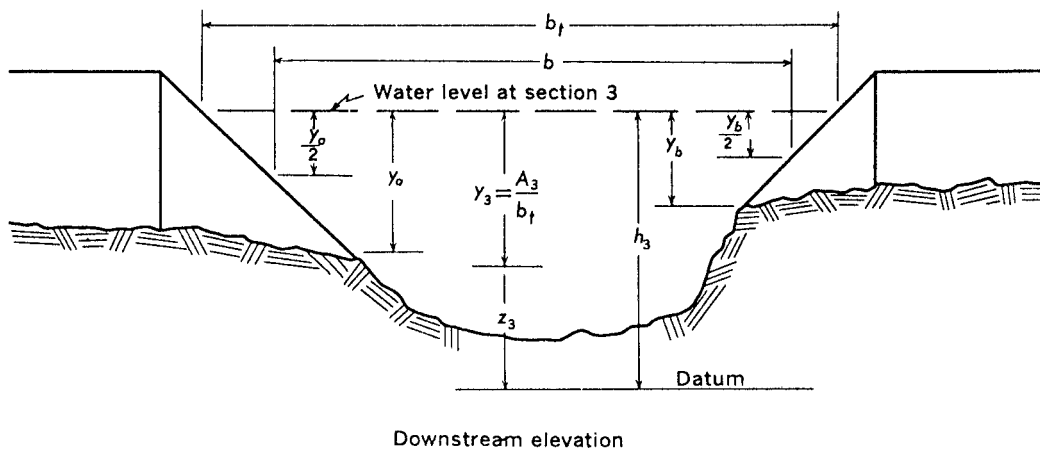
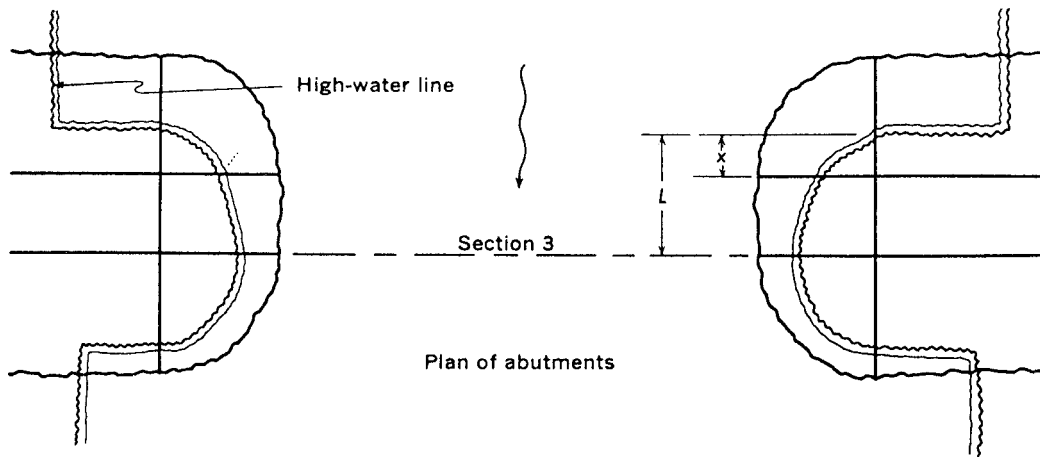

FIG. 5 Definition Sketch of a Type 3 Opening, Sloping Embankments and Sloping Abutments

ASTM D 5129

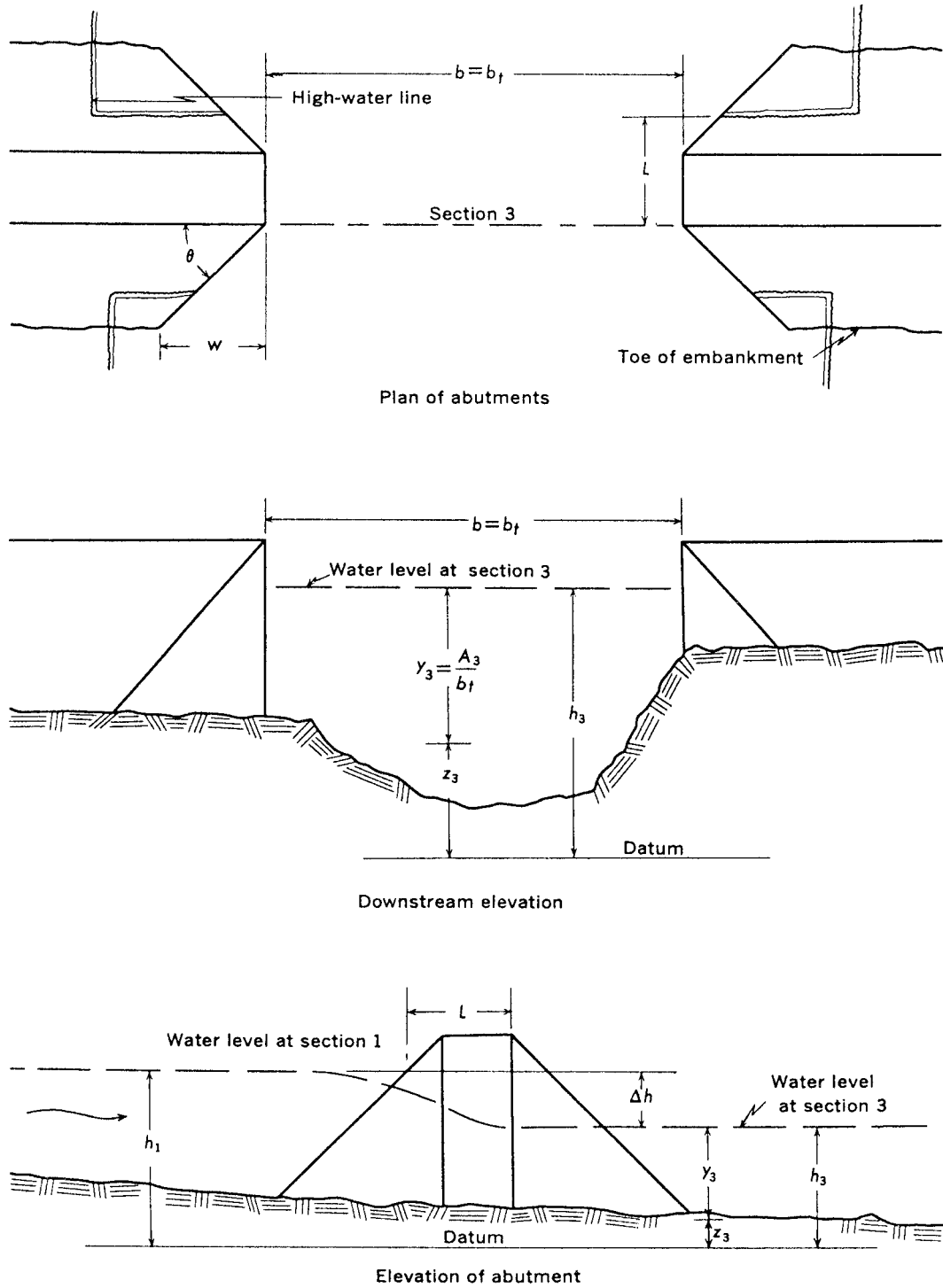

FIG. 6 Definition Sketch of a Type 4 Opening, Sloping Embankments and Vertical Abutments With Wingwalls

ASTM D 5129

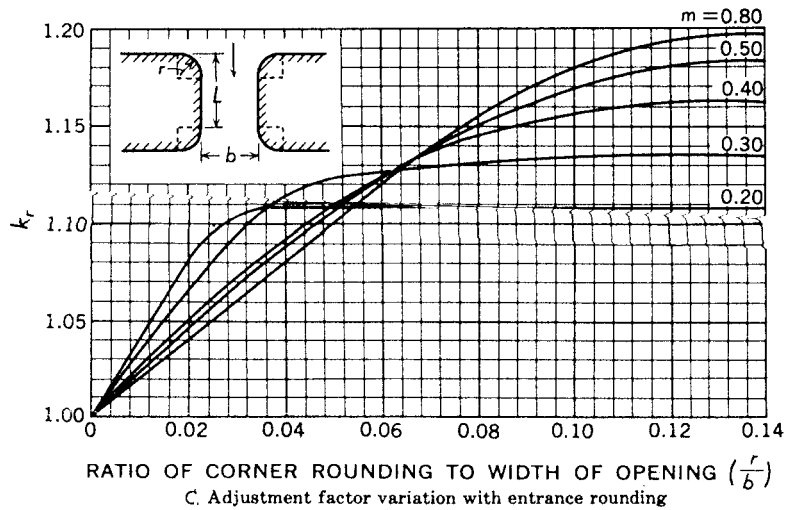
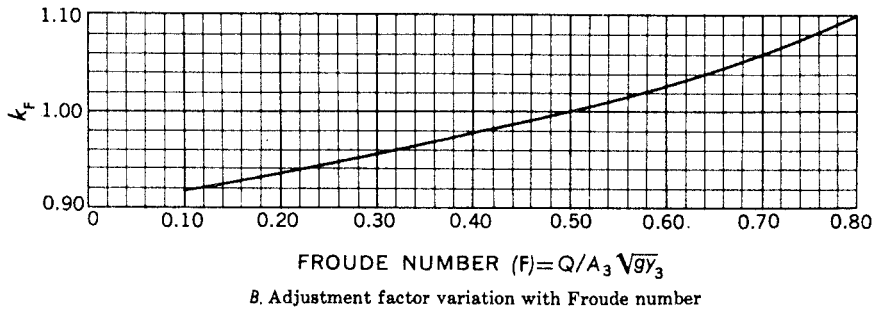
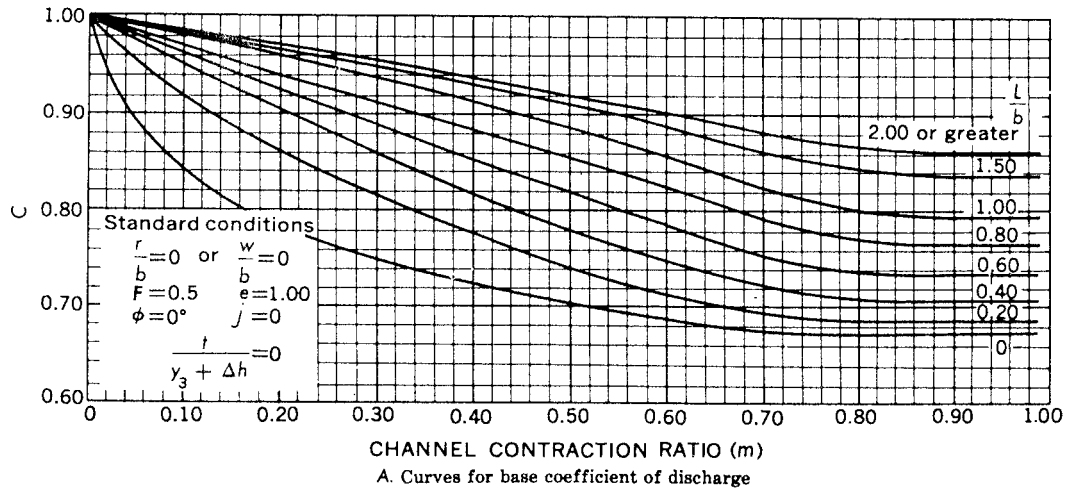
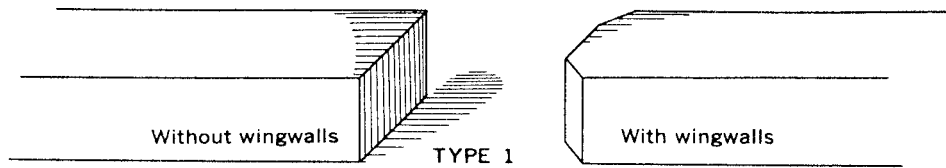

FIG. 7 Coefficients for Type 1 Opening, Vertical Embankments and Vertical Abutments

ASTM D 5129

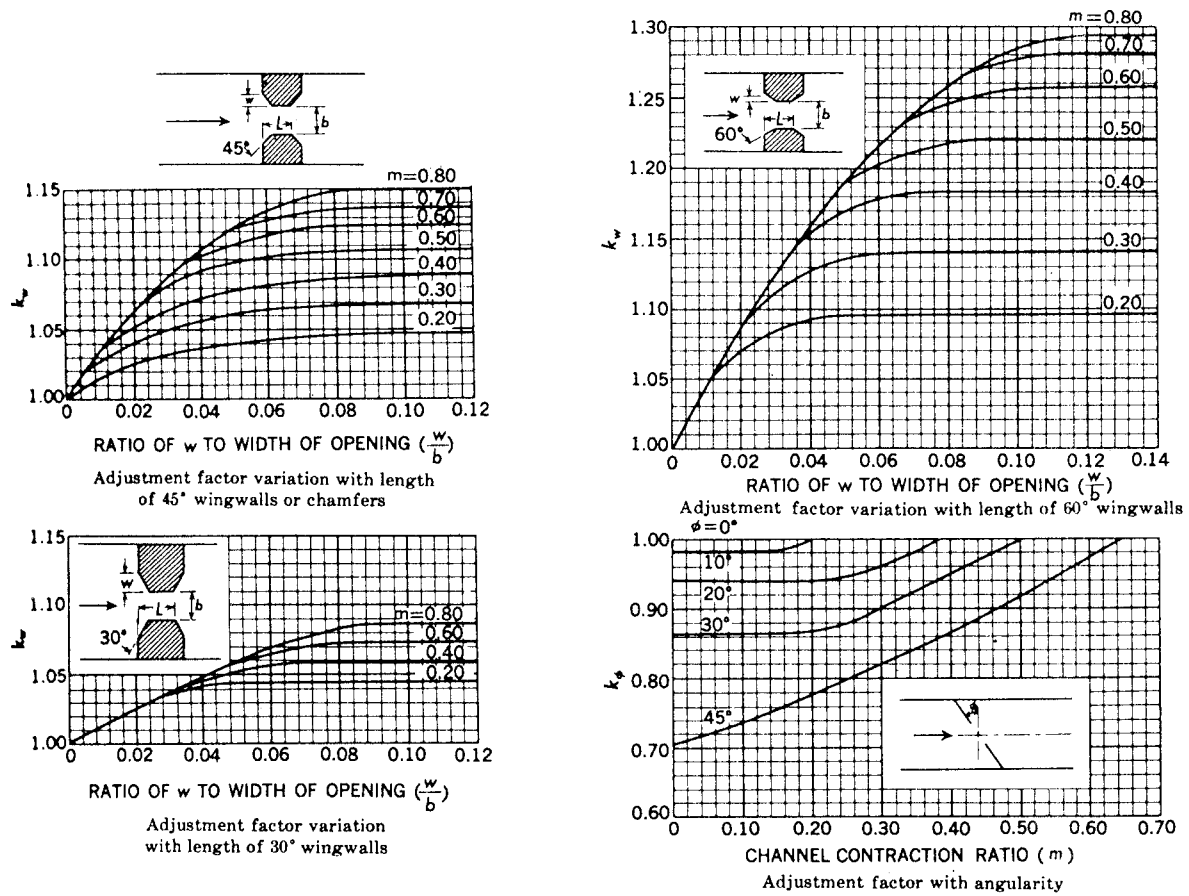

FIG. 8 Adjustment Factor Variation for Vertical Embankment and Abutment of Type 1 Opening

ASTM D 5129

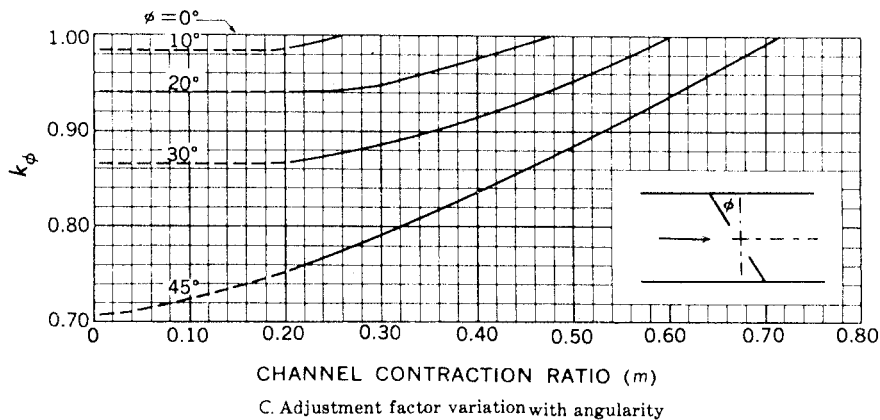
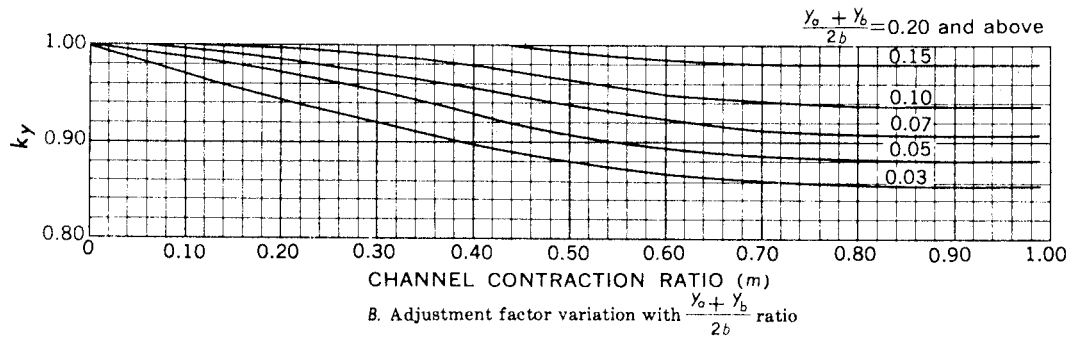
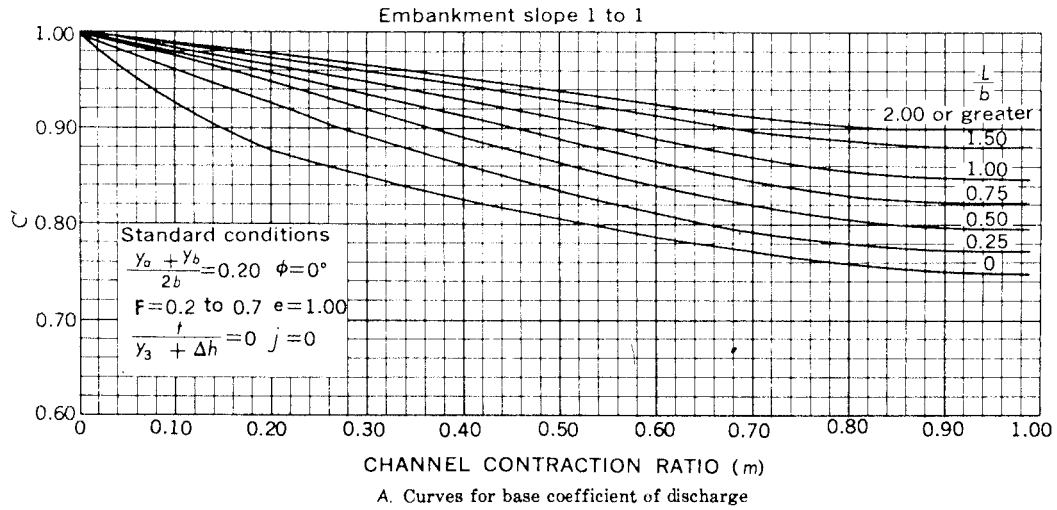
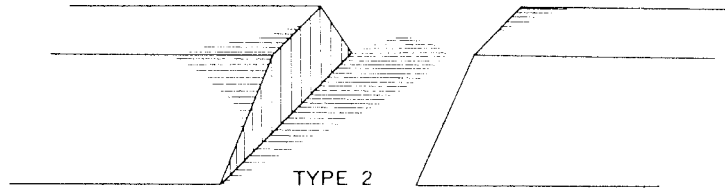

FIG. 9 Coefficients for Type 2 Opening, Embankment Slope 1 to 1, Vertical Abutment

ASTM D 5129

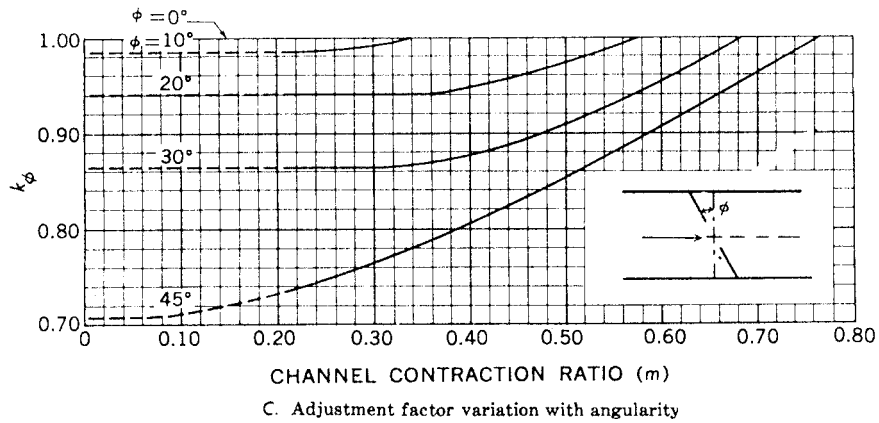
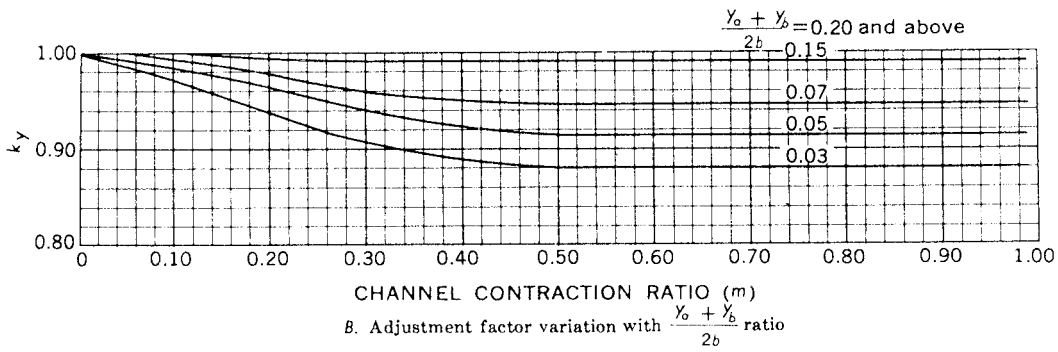
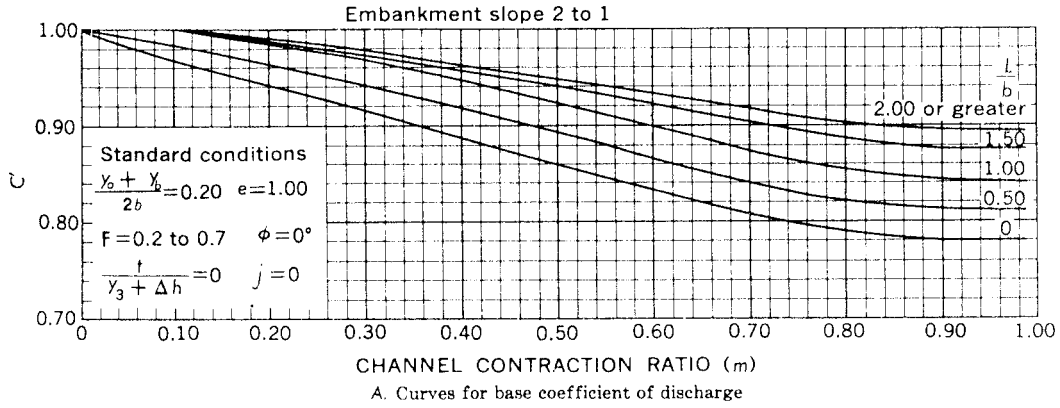
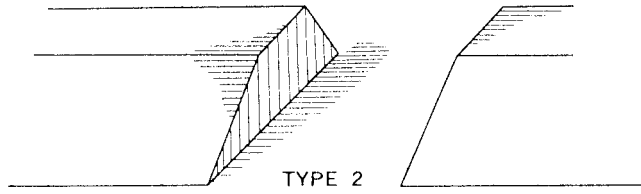

FIG. 10 Coefficients for Type 2 Opening, Embankment Slope 2 to 1, Vertical Abutment

ASTM D 5129

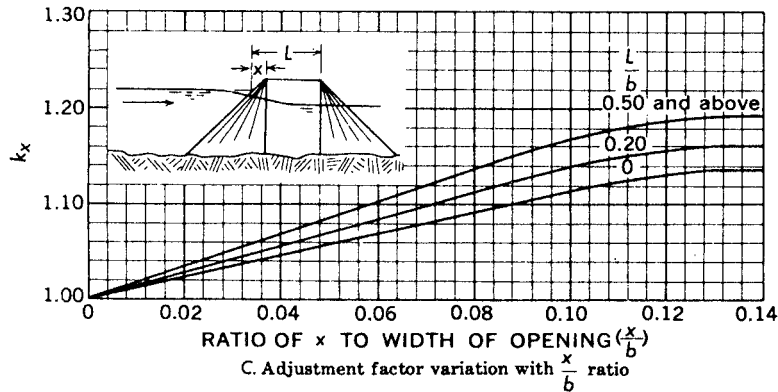
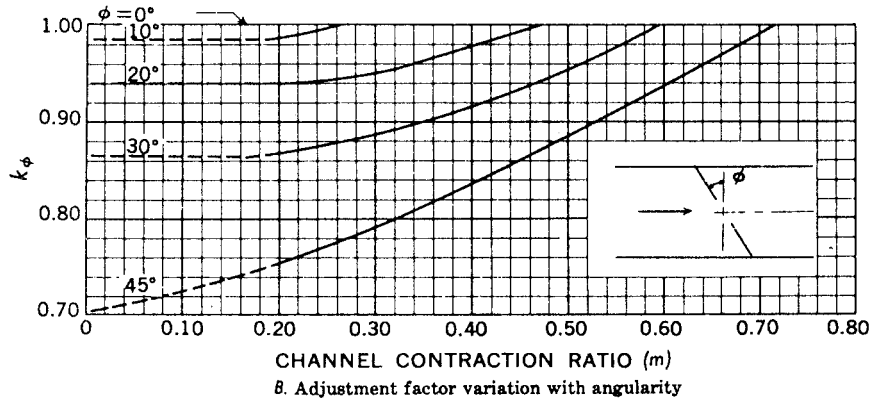
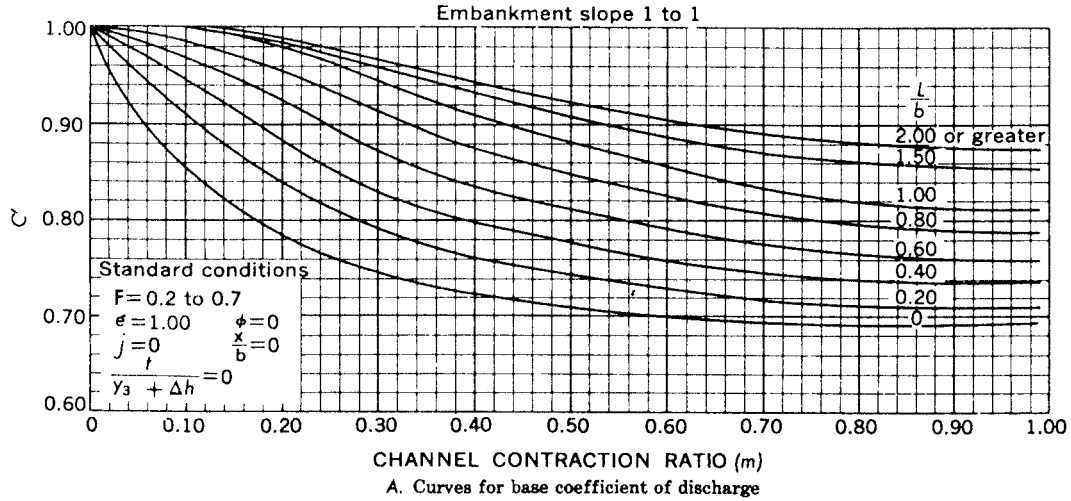
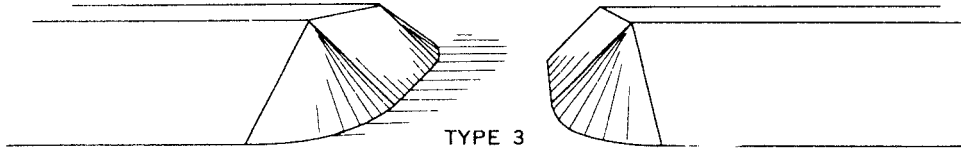

FIG. 11 Coefficients for Type 3 Opening, Embankment and Abutment Slope 1 to 1

ASTM D 5129

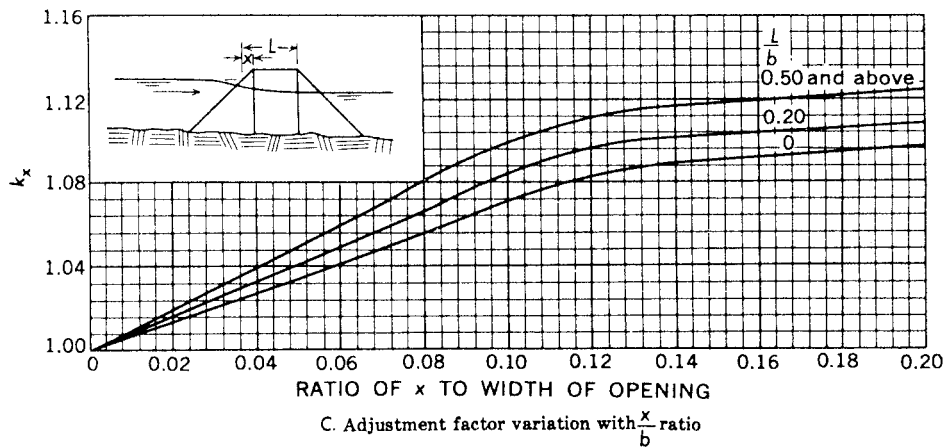
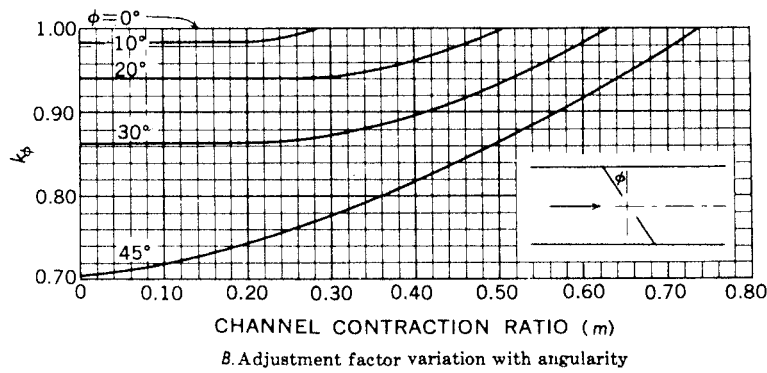
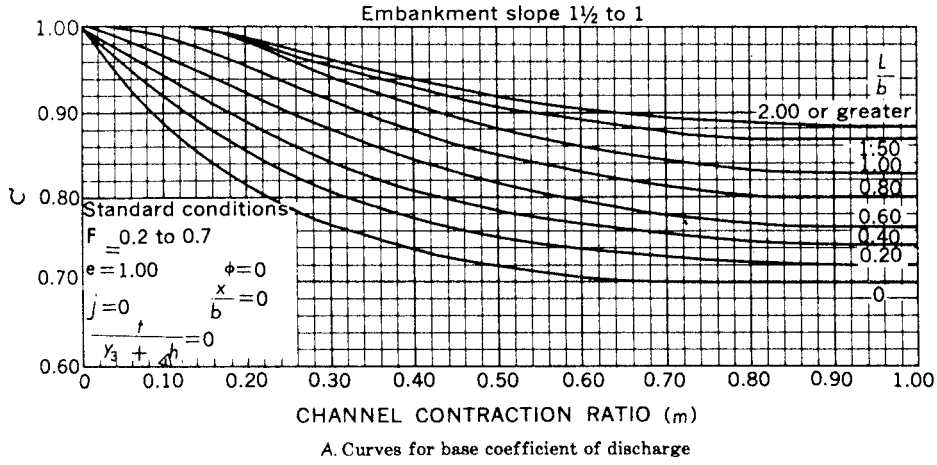
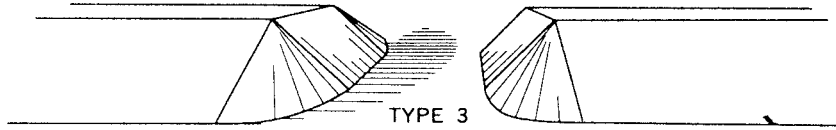

FIG. 12 Coefficients for Type 3 Opening, Embankment and Abutment Slope $1\frac{1}{2}$ to 1

ASTM D 5129

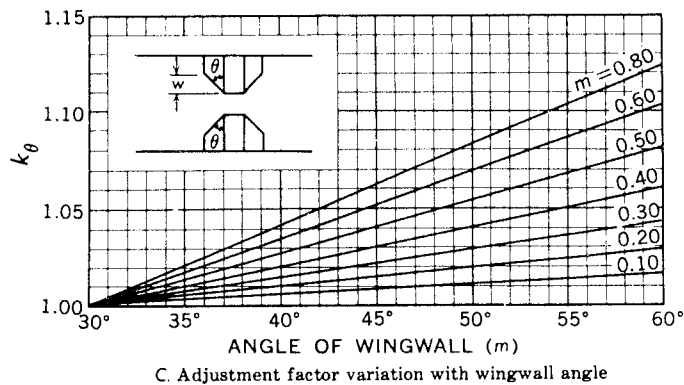
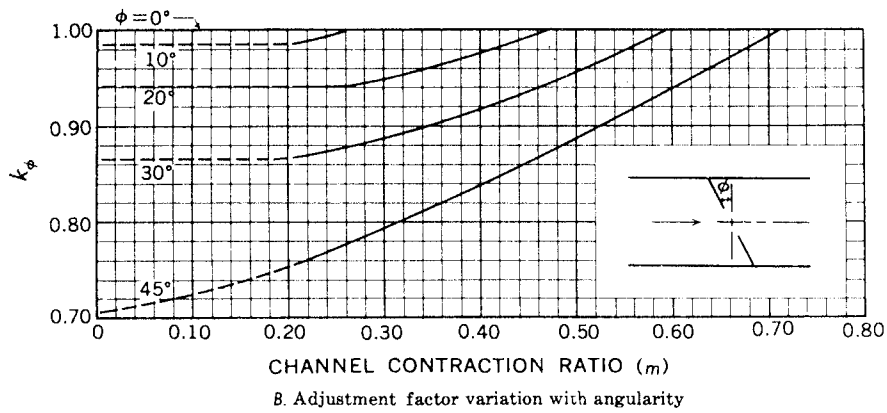
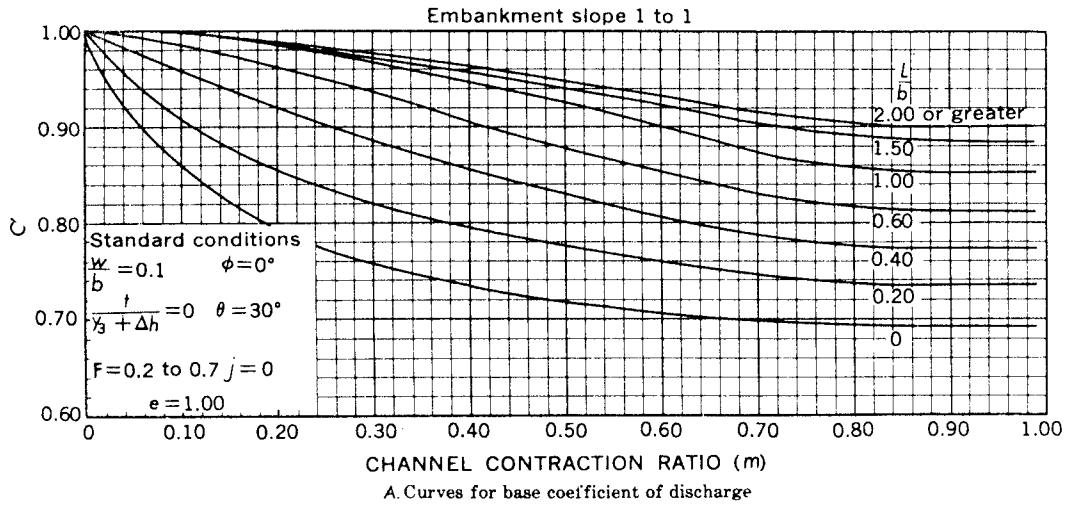
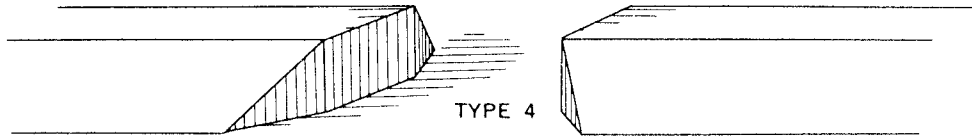

FIG. 14 Coefficients for Type 4 Opening, Embankment Slope 1 to 1, Vertical Abutments With Wingwalls

ASTM D 5129

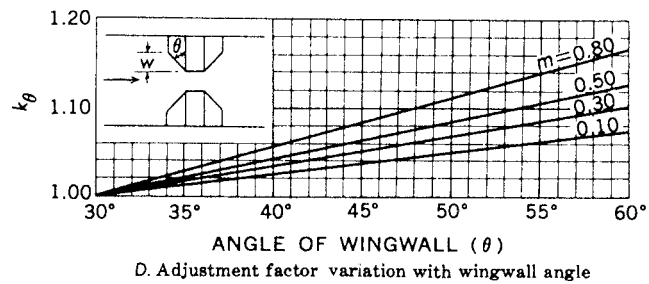
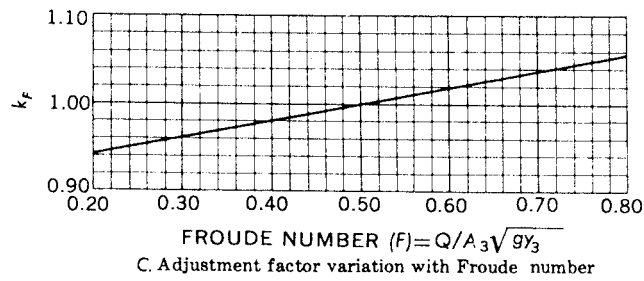
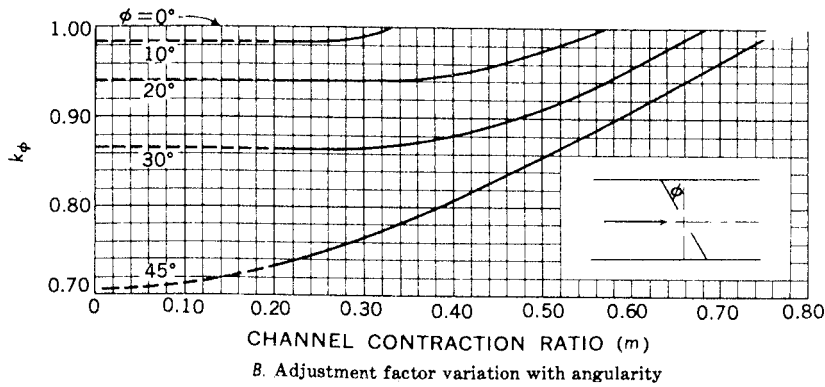
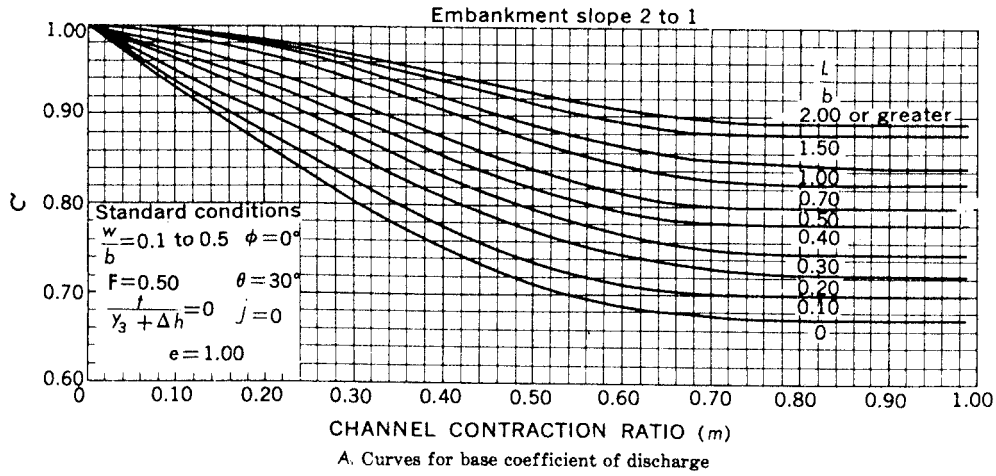
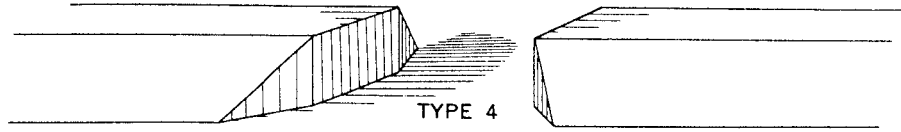

FIG. 15 Coefficients for Type 4 Opening, Embankment Slope 2 to 1, Vertical Abutments With Wingwalls

ASTM D 5129

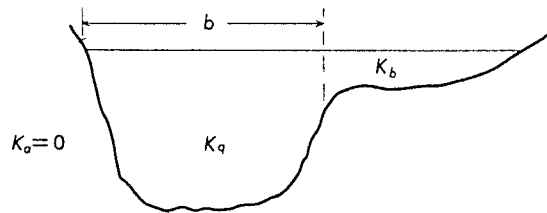
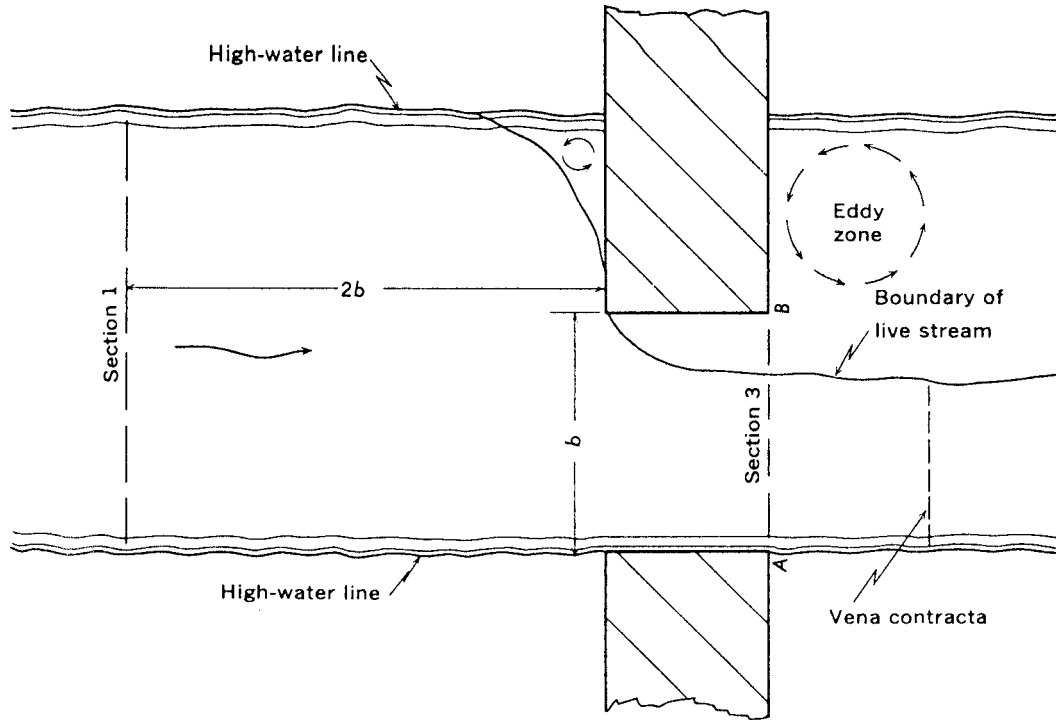

FIG. 16 Definition Sketch of a Fully Eccentric Contraction

ASTM D 5129

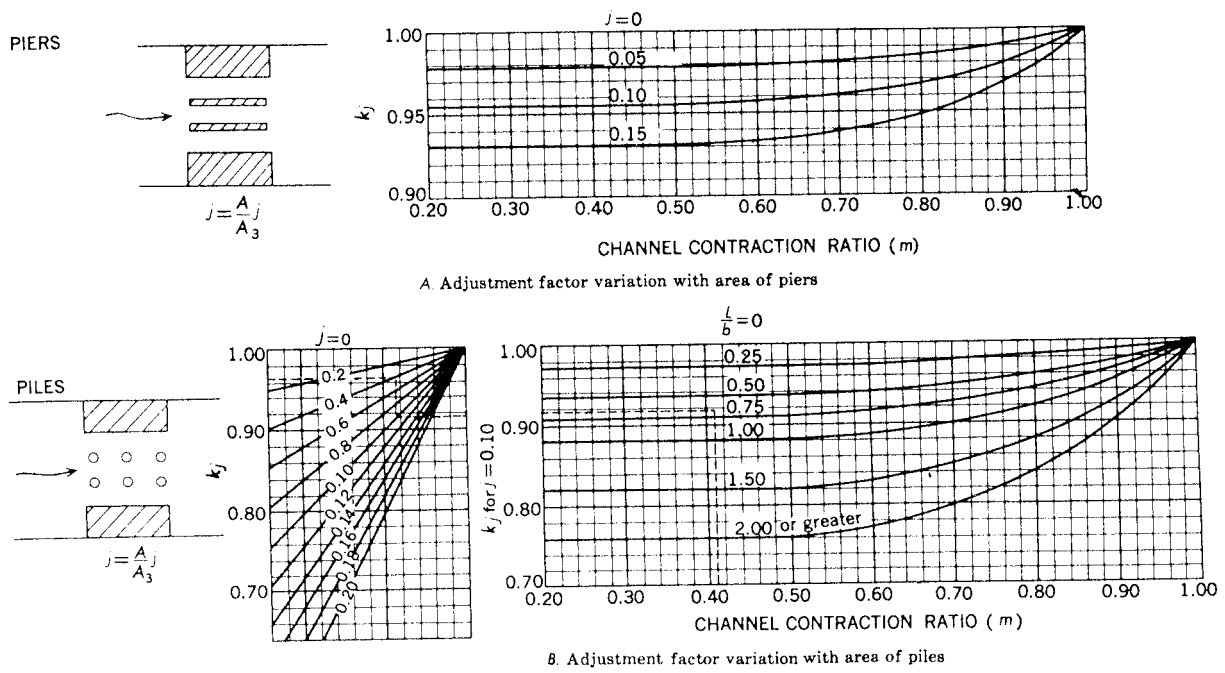

FIG. 17 Adjustment Factor Variation for Piers and Piles

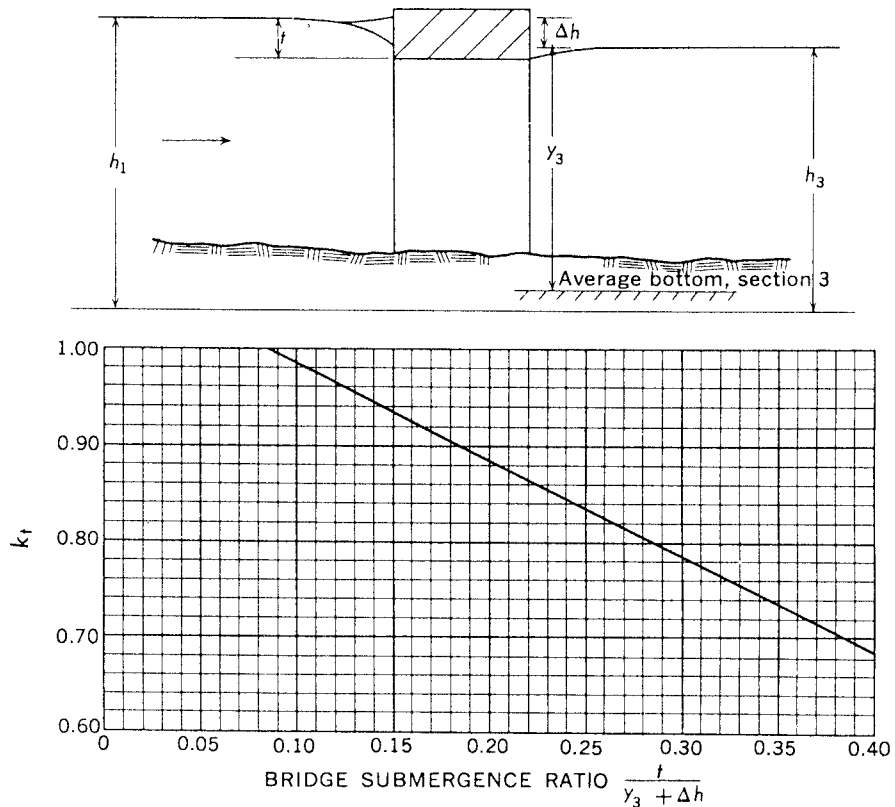
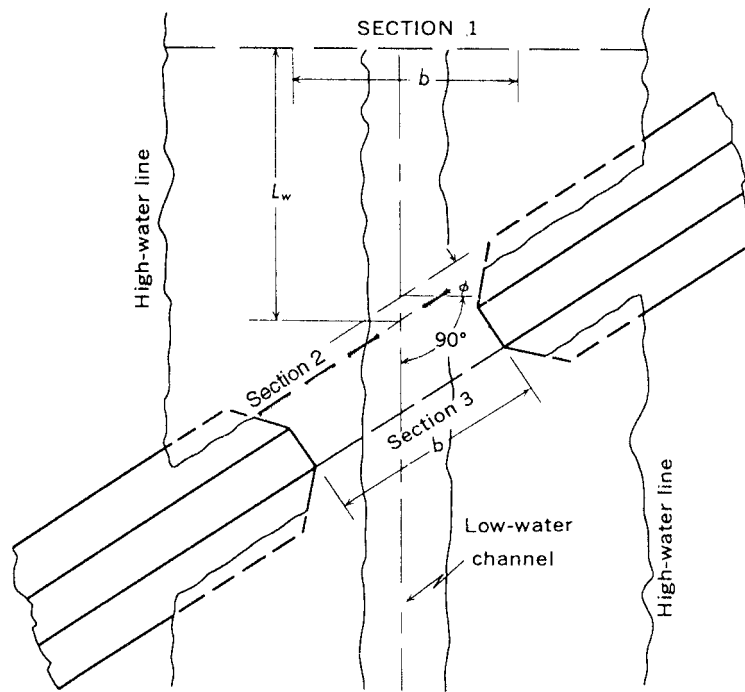

FIG. 18 Adjustment Factor Variation with Bridge Submergence Ratio

ASTM D 5129



ϕ is a measure of angularity

A. Condition of angularity

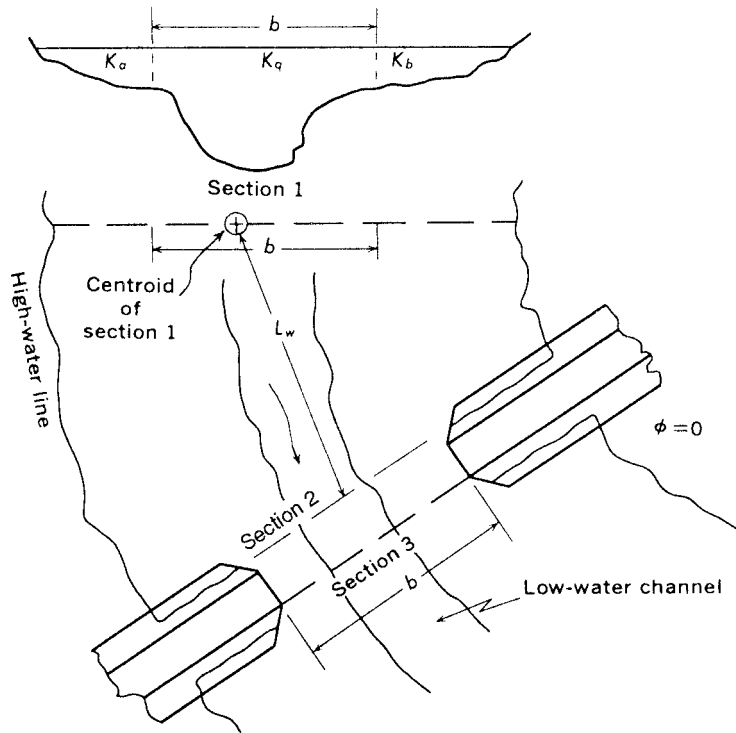

B. Condition of channel curvature

FIG. 19 Definition Sketch Comparing Conditions of Angularity and Channel Curvature

ASTM D 5129

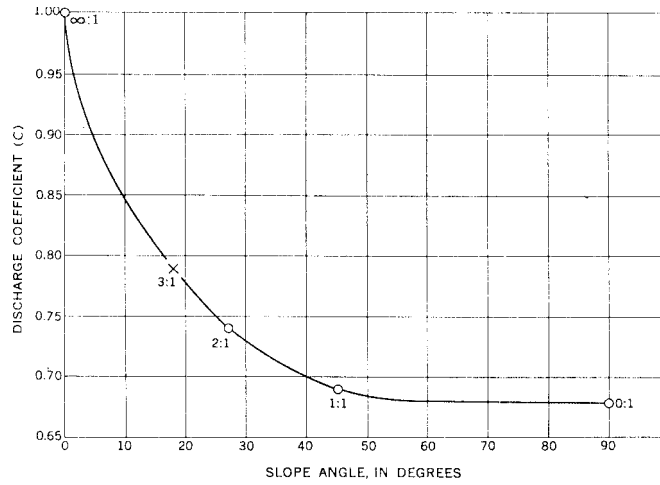

1. Type 1. Slope angle = 90°
 $C = C' \times k \times k = 0.68$
 2. Type 2 or 3. 1:1 slope = 45°
 $C = C' \times k \times k = 0.69$
 3. Type 2 or 3. 2:1 slope = 27°
 $C = C' \times k \times k = 0.74$
 4. No embankment. ∞: 1 slope = 0°
Assume $C = 1.00$
- Example—For 3:1 slope, or 18°, C from curve is 0.79.

FIG. 20 Method to Determine Discharge Coefficient for Embankment Slope Other than 1 to 1 or 2 to 1

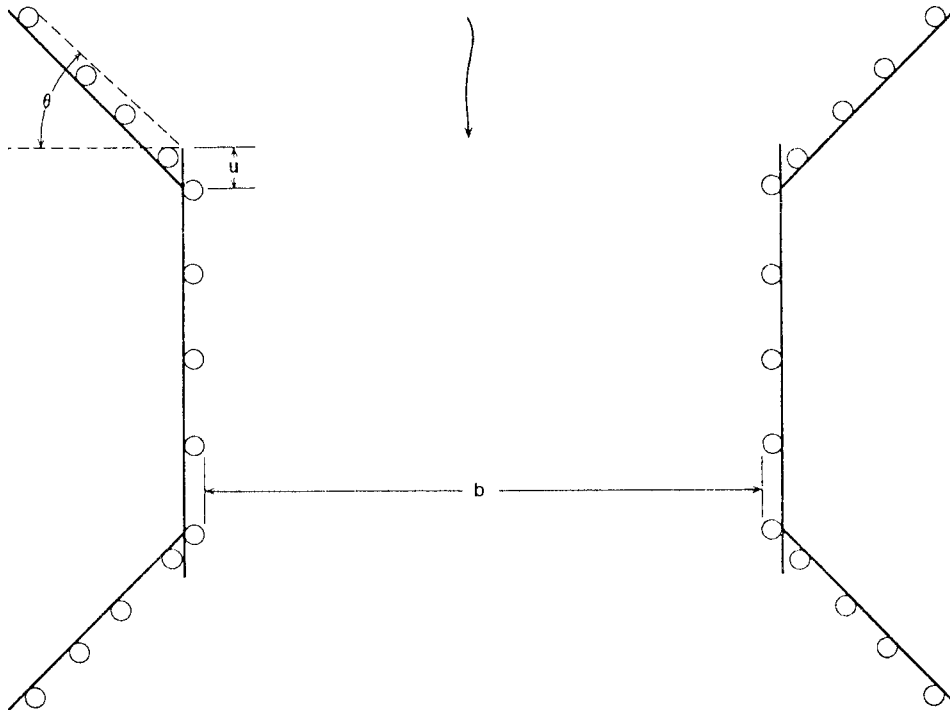

FIG. 21 Definition Sketch of Timber-and-Pile Bridge With Projecting Abutments

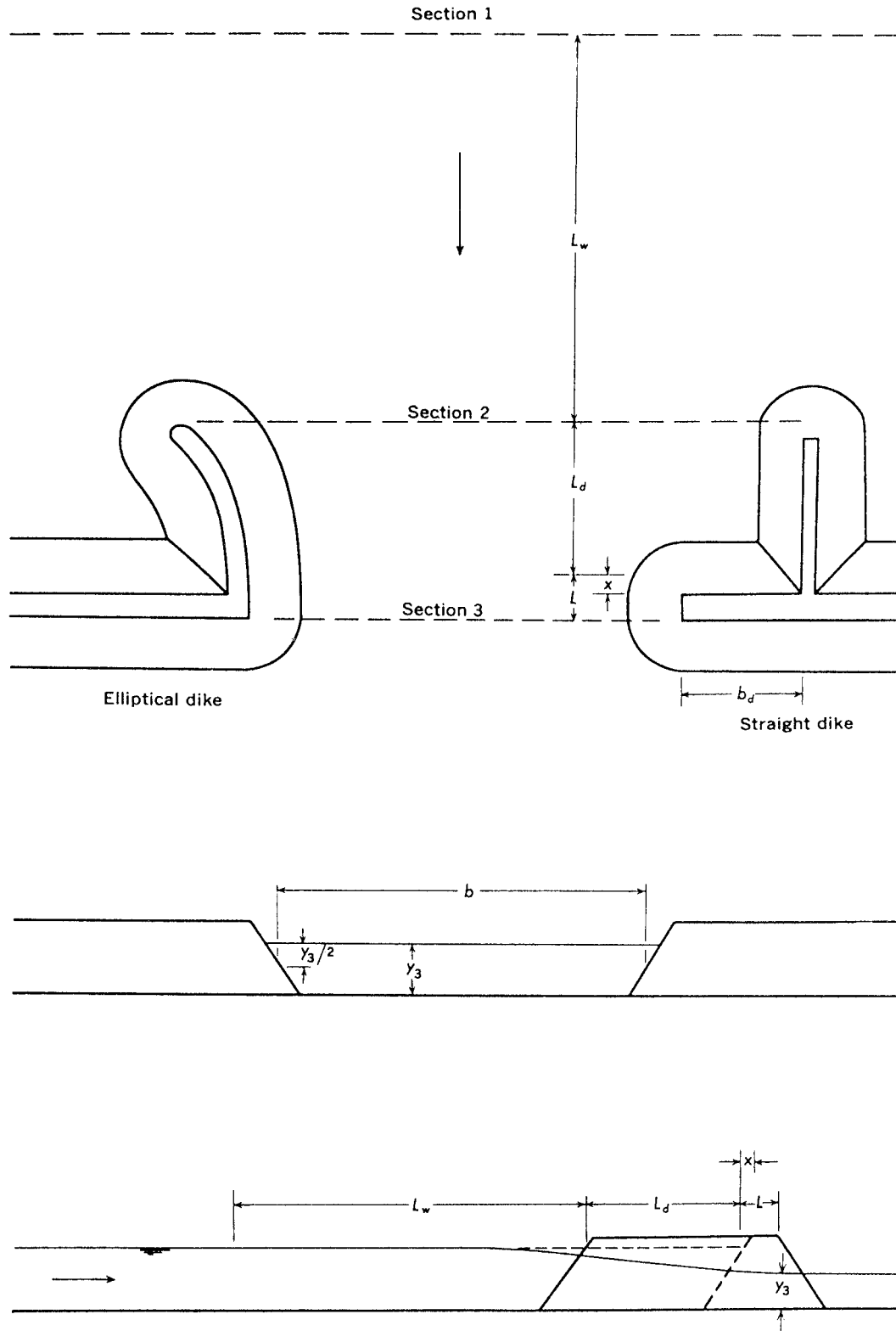
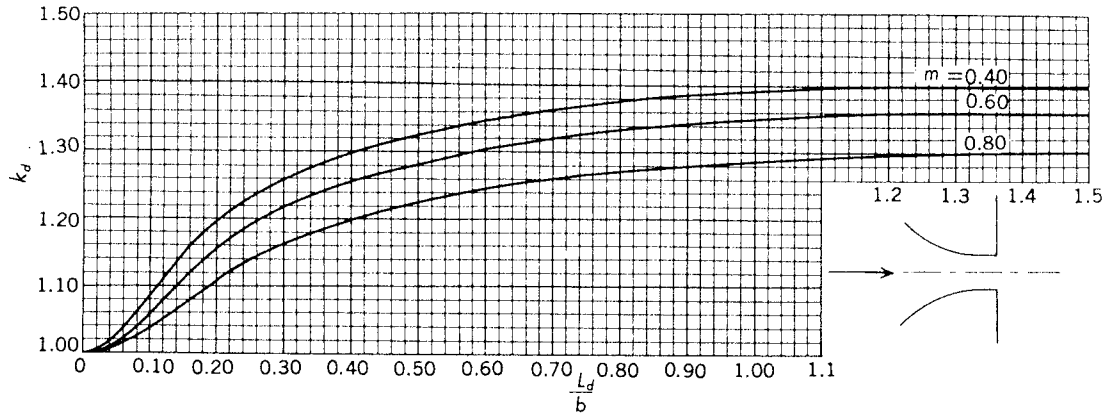
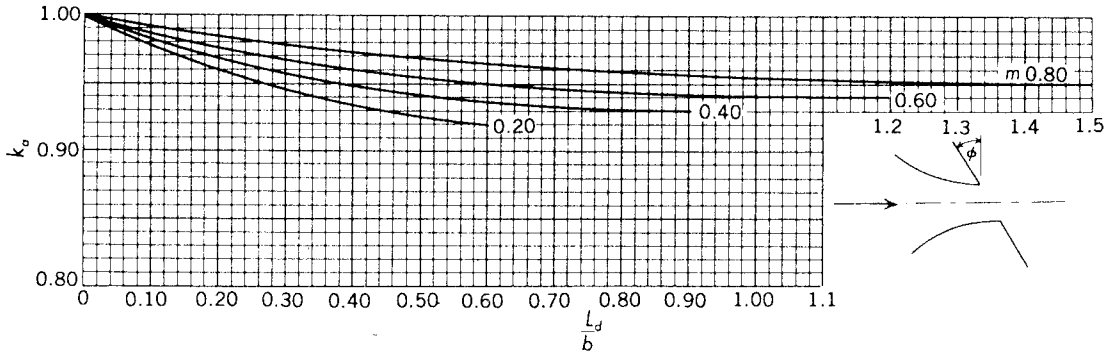

FIG. 22 Definition Sketches of Spur Dikes

ASTM D 5129



A. Adjustment factor variation with elliptical dike length



B. Adjustment factor variation with elliptical dike angularity

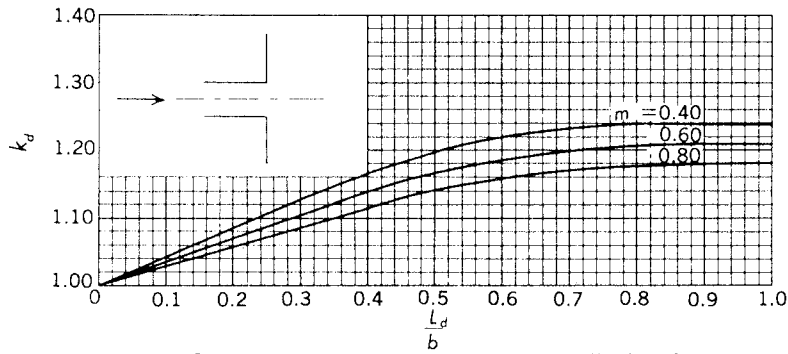

C. Adjustment factor variation with straight dike length

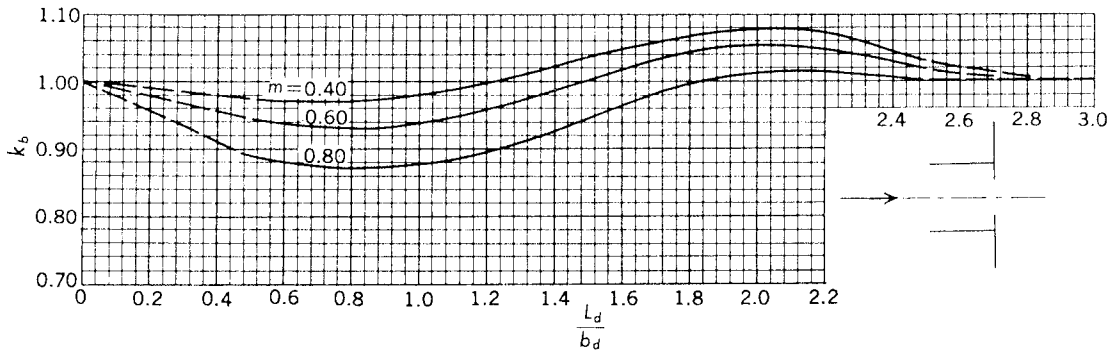

D. Adjustment factor variation with straight dike offset

FIG. 23 Adjustment Factor Variation for Spur Dikes

Roaring River near Lyon, Colo. - Flood of July 3, 1961

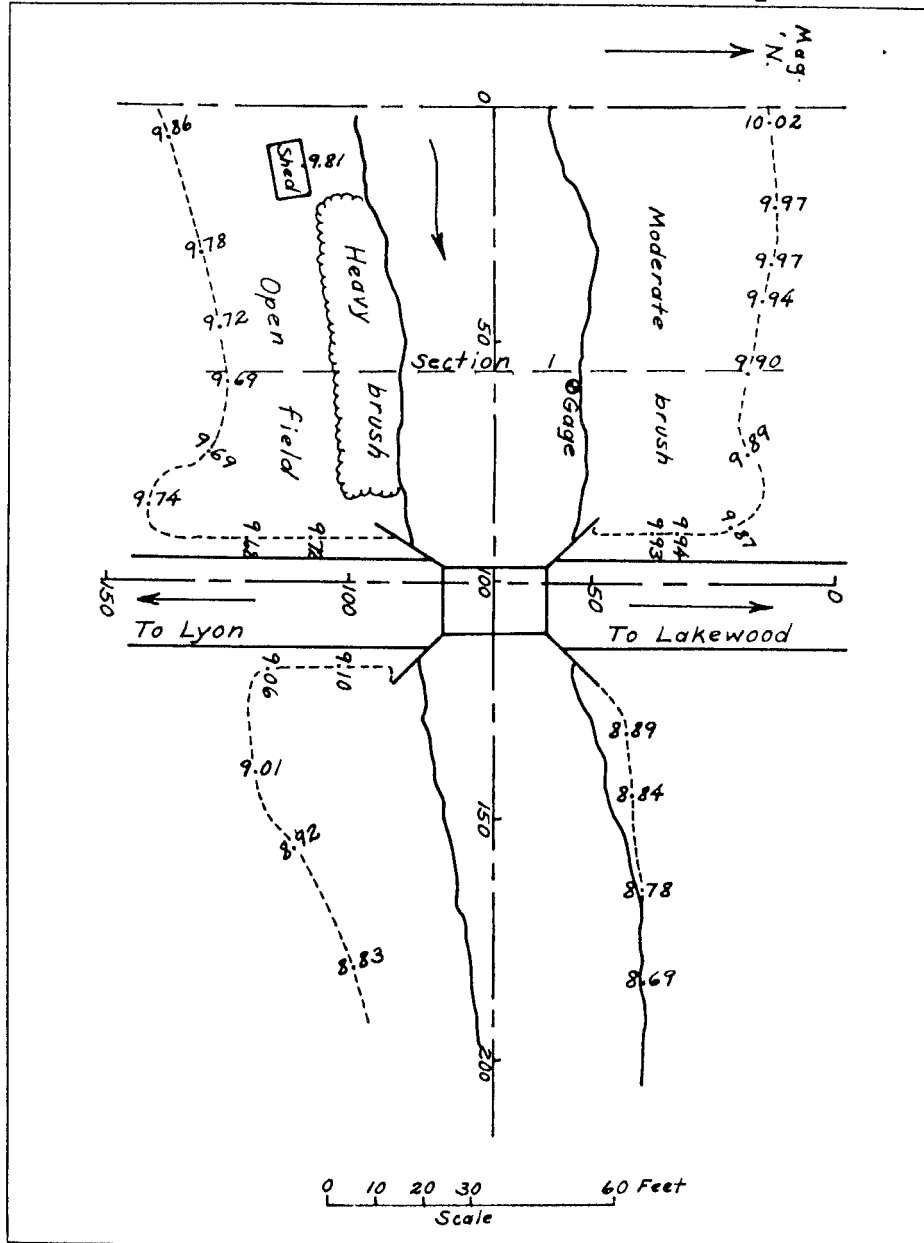

Sheet No. 1 of 10 Sheets. Prepared by H. S. C. Date 7-7-61. Checked by E. R. H. Date 7-10-61

FIG. 24 Sample Contracted-Opening Computation, Location Plan

ASTM D 5129

Roaring River near Lyon, Colo Flood of 7-3-61

High-water marks						
Left bank			Right bank			
Sta.	Elev.		Sta.	Elev.		
3	10.02		7	9.86		
21	9.97		14	9.81	in shed	
33	9.97		31	9.78		
41	9.94		48	9.72		
55	(9.91)	Sec 1	56	(9.70)	Sec 1	
56	9.90		58	9.69		
73	9.89		73	9.69		
88	9.87		84	9.74		
89	9.94		91	9.68		
90	9.93		91	9.72		
87	-	Upstr wingwalls	87	-	Upstr wingwall	
97	-	Upstr. bridge	97	-	Upstr. bridge	
111	(8.91)	Sec 3	111	(9.08)	Sec 3	
132	8.89		118	9.10		
144	8.84		119	9.06		
164	8.78		141	9.01		
183	8.69		156	8.92		
			181	8.83		
Transverse profile						
Upstream			Downstream			
L.B.	17	9.89	L.B.	40	8.78	
	21	9.87		41	8.84	
	32	9.94		43	8.89	
	37	9.93		59	-	L. abut.
	49	-		80	-	R. abut.
	97	-		101	9.10	
	107	9.72		116	9.06	
	121	9.68	R.B.	119	9.01	
R.B.	141	9.74				

Comp. D.E.F.
 checked G.H.S.
 2 of 10

FIG. 25 Sample Contracted-Opening Computation, List of High-Water Marks

Roaring River near Lyon, Colo. Flood of July 3, 1961

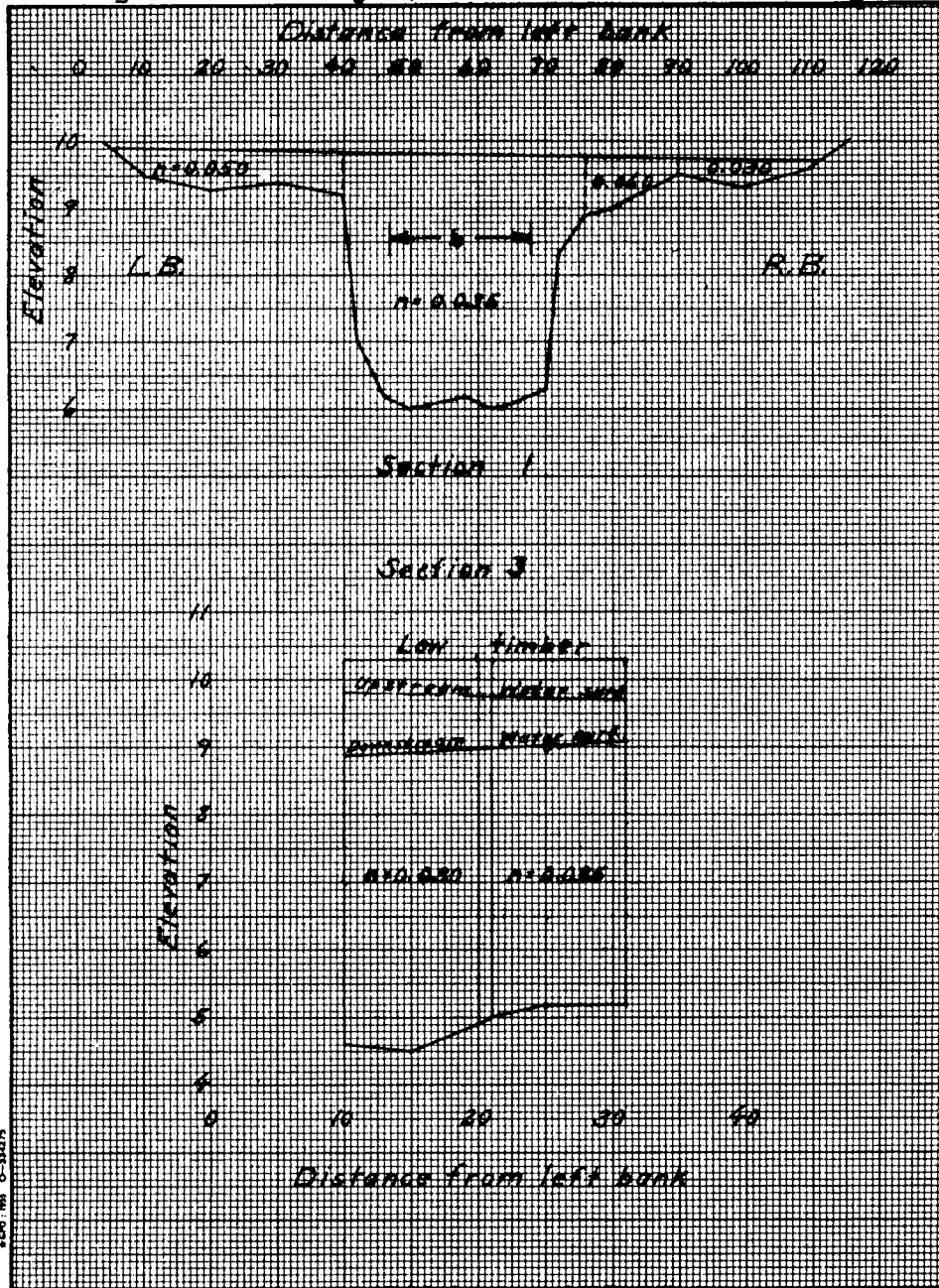

Sheet No. 5 of 10 Sheets. Prepared by H.S.C. Date 7-10-61 Checked by E.R.H. Date 7-12-61

FIG. 27 Sample Contracted-Opening Computation, Bridge Geometry

----- Roaring River near Lyon, Colo. ----- Flood of July 3, 1961

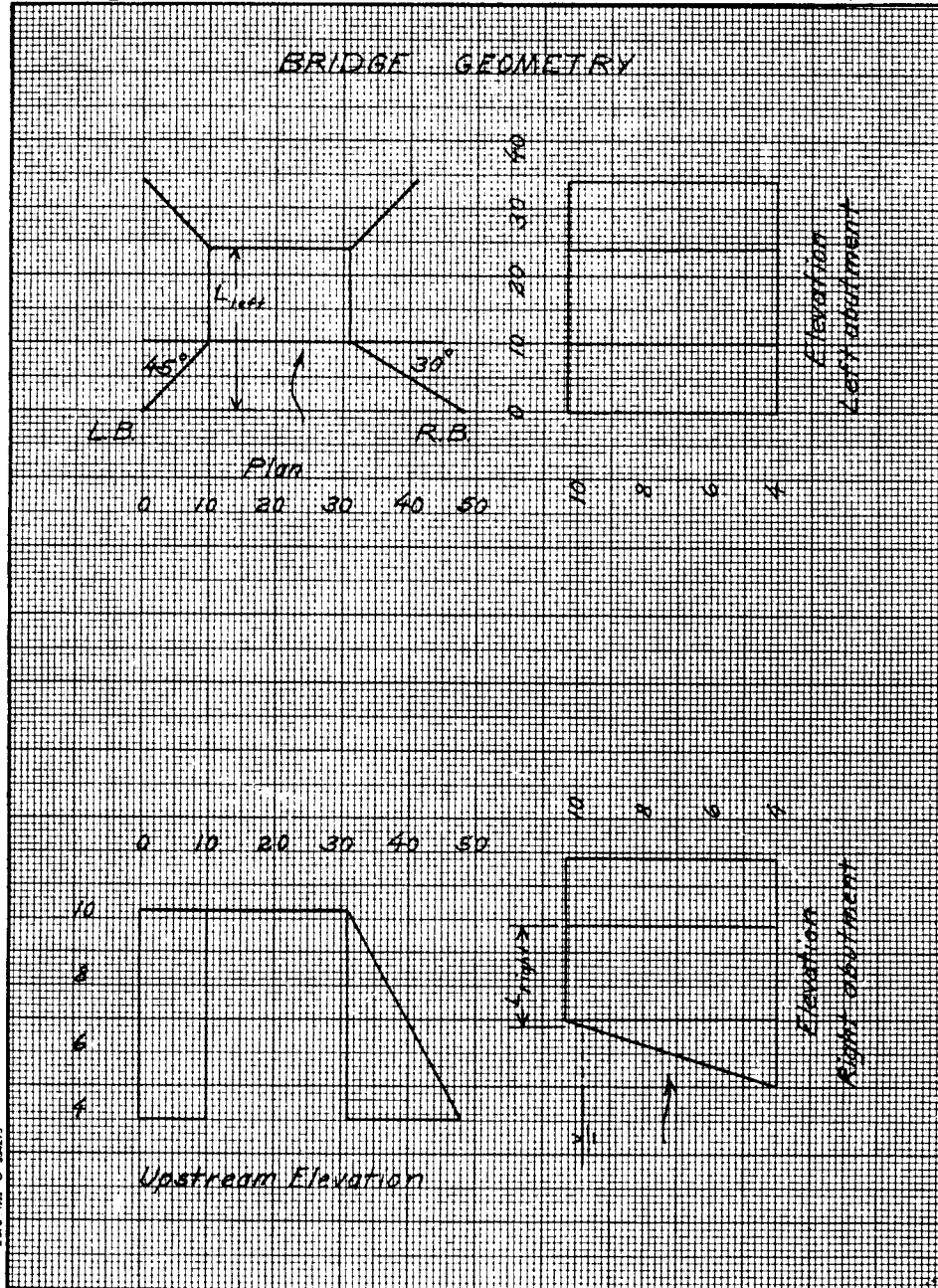

Sheet No. 4 of 10 Sheets. Prepared by H. S. C. Date 7-12-61 Checked by E. R. H. Date 7-12-61

FIG. 28 Sample Contracted-Opening Computation, Cross Sections

ASTM D 5129

Roaring River near Lyon, Colo. FLOOD OF July 3, 1961

SECTION - 1 (Approach section)									
STA.	DIST.	W. S. ELEV.	ELEV.	DEPTH	MEAN DEPTH	AREA	Cumul. Area	W. P.	
L. B. 4			10.0						
(5)	—	9.9	(9.9)	0	—	—			
10	5		9.5	.4	0.2	1.0	1.0	5.0	A = 17.0
20	10		9.3	.6	.5	5.0	6.0	10.0	WP = 35.0
30	10	9.9	9.4	.5	.55	5.5	11.5	10.0	
40	10	9.8	9.2	.6	.55	5.5	17.0	10.0	
42	2		7.0	2.8	1.7	3.4	20.4	3.0	
46	4		6.2	3.6	3.2	12.8	33.2	4.1	
50			6.0	3.8	3.7	14.8	48.0	4.0	
54			6.1	3.7	3.75	15.0	63.0	4.0	A = 131.6 - 17.0
58			6.2	3.6	3.65	14.6	77.6	4.0	= 114.6
62			6.0	3.8	3.7	14.8	92.4	4.0	WP = 37.9
66			6.1	3.7	3.75	15.0	107.4	4.0	
70	4		6.3	3.5	3.6	14.4	121.8	4.0	
72	2		8.3	1.5	.25	5.0	126.8	2.8	
76	4		8.9	.9	1.2	4.8	131.6	4.0	
80	4	9.8	9.0	.8	.85	3.4	135.0	4.0	A = 140.5 - 131.6 = 8.9
90	10	9.7	9.5	.3	.55	5.5	140.5	10.0	WP = 14.0
100	10		9.3	.5	.4	4.0	144.5	10.0	A = 148.2 - 140.5
110	10		9.6	.2	.35	3.5	148.0	10.0	= 7.7
(112)	2	9.7	(9.7)	0	.1	.2	148.2	2.0	WP = 22.0
116			10.0						
107	107					148.2			

Sheet No. 6 of 14 sheets. Prepared by H. S. C. Date 7-10-61. Checked by R. E. H. Date 7-12-61

FIG. 29 Sample Contracted-Opening Computation, Cross-Sectional Properties of Section 1

ASTM D 5129

Computation of channel-contraction ratio, m.
Roaring River near Lyon, CO for flood of July 3, 1989

APPROACH SECTION		SECTION 1							
Subsection	n	$\frac{1.486}{n}$	a	w.p.	r	r ^{2/3}	$K = \frac{1.486}{n} ar^{2/3}$		
5 - 40	0.050	29.7	17.0	35.0	0.49	0.62	310		
40 - 47	.035	42.5	19.9	8.1	2.46	1.82	1540	1850	K ₆
47 - 68	.035	42.5	77.7	21.0	3.70	2.39	7890	7890	K ₇
68 - 76	.036	42.5	17.0	8.8	1.93	1.55	1120		
76 - 90	.060	24.8	8.9	14.0	.64	.74	160		
90 - 112	.030	49.5	7.7	22.0	.35	.50	190	1470	K ₂
Total			148.2	108.9			11210		

$$m = \frac{K_2 + K_6}{K_2 + K_7 + K_6} = \frac{1470 + 1850}{11210} = 0.30$$

FIG. 30 Computation of Channel-Contraction Ratio, m

ASTM D 5129

Roaring River near Lyon, Colo. FLOOD OF July 3, 1989

SECTION - 3 (Contracted section)									
STA.	DIST.	W. S. ELEV.	ELEV.	DEPTH	MEAN DEPTH	AREA		W. P.	
L. B.									
10	—	8.91	8.9	0	—	—		—	
10	0	8.9	4.6	4.3	—	—		4.3	
15	5	9.0	4.5	4.5	4.4	22.0		5.0	A=43.5
20	5		4.9	4.1	4.3	21.5		5.0	WP=18.4
20	0		9.0	0	—	—		4.1	
Piles	1		—	—	Pile area 4.0				
21	—		9.0	0	—	—		—	
21	0		5.0	4.0	—	—		4.0	
25	4	9.0	5.2	3.8	3.9	15.6		4.0	A=38.7
31	6	9.1	5.2	3.9	3.85	23.1		6.0	WP=17.9
31	0	9.08	9.1	0	—	—		3.9	
21	21					82.2 net area			
						4.0 pile area			
						86.2 gross area = A ₃			

Sheet No. 8 of 10 sheets. Prepared by H. S. C. Date 7-10-89 Checked by E. R. H. Date 7-12-89

FIG. 31 Sample Contracted-Opening Computation, Cross-Sectional Properties of Section 3

ASTM D 5129

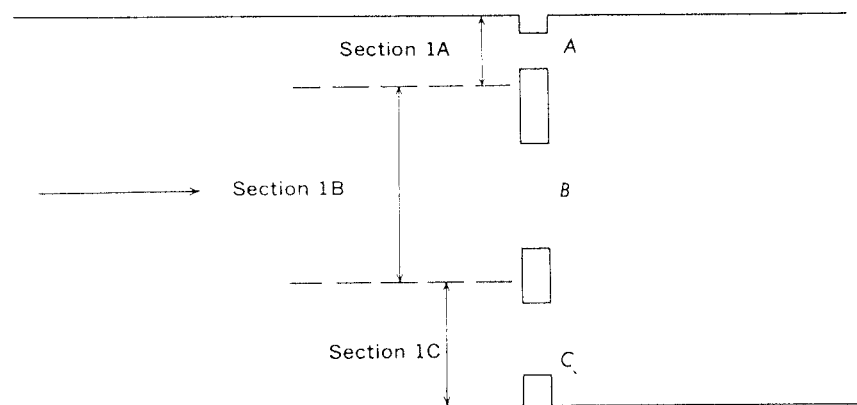

FIG. 34 Location of Approach Section and Flow Division Lines for a Multiple-Opening Constriction

The American Society for Testing and Materials takes no position respecting the validity of any patent rights asserted in connection with any item mentioned in this standard. Users of this standard are expressly advised that determination of the validity of any such patent rights, and the risk of infringement of such rights, are entirely their own responsibility.

This standard is subject to revision at any time by the responsible technical committee and must be reviewed every five years and if not revised, either reapproved or withdrawn. Your comments are invited either for revision of this standard or for additional standards and should be addressed to ASTM Headquarters. Your comments will receive careful consideration at a meeting of the responsible technical committee, which you may attend. If you feel that your comments have not received a fair hearing you should make your views known to the ASTM Committee on Standards, at the address shown below.

This standard is copyrighted by ASTM, 100 Barr Harbor Drive, PO Box C700, West Conshohocken, PA 19428-2959, United States. Individual reprints (single or multiple copies) of this standard may be obtained by contacting ASTM at the above address or at 610-832-9585 (phone), 610-832-9555 (fax), or service@astm.org (e-mail); or through the ASTM website (www.astm.org).