



Designation: D 5614 – 94 (Reapproved 1998)

Standard Test Method for Open Channel Flow Measurement of Water with Broad- Crested Weirs¹

This standard is issued under the fixed designation D 5614; the number immediately following the designation indicates the year of original adoption or, in the case of revision, the year of last revision. A number in parentheses indicates the year of last reapproval. A superscript epsilon (ϵ) indicates an editorial change since the last revision or reapproval.

1. Scope

1.1 This test method covers measurement of the volumetric flow rate of water in open channels with two types of horizontal broad-crested weirs: those having a square (sharp) upstream corner and those having a well-rounded upstream corner.

1.2 The values stated in inch-pound units are to be regarded as the standard. The values given in parentheses are for information only.

1.3 *This standard does not purport to address all of the safety concerns, if any, associated with its use. It is the responsibility of the user of this standard to establish appropriate safety and health practices and determine the applicability of regulatory limitations prior to use.*

2. Referenced Documents

2.1 ASTM Standards:

D 1129 Terminology Relating to Water²

D 2777 Practice for Determination of Precision and Bias of Applicable Methods of Committee D-19 on Water²

D 3858 Practice for Open-Channel Flow Measurement of Water by Velocity-Area Method²

2.2 ISO Standards:

ISO 555-1973 Liquid Flow Measurement in Open Channels—Dilution Methods for Measurement of Steady Flow—Constant Rate Injection Method³

ISO 3846-1989 Liquid Flow Measurement in Open Channels by Weirs and Flumes—Rectangular Broad-Crested Weirs³

ISO 4373-1979 Measurement of Liquid Flow in Open Channels—Water Level Measuring Devices³

ISO 4374-1990 Liquid Flow Measurement in Open Channels by Weirs and Flumes—Round-Nose Horizontal Crest Weirs³

3. Terminology

3.1 *Definitions*—For definitions of terms used in this test method, refer to Terminology D 1129.

3.2 Definitions of Terms Specific to This Standard:

3.2.1 *boundary layer displacement thickness*—the boundary layer is a layer of fluid flow adjacent to a solid surface (in this case, the weir crest and sidewalls) in which, due to viscous friction, the velocity increases from zero at the stationary surface to an essentially frictionless-flow value at the edge of the layer. The displacement thickness is a distance normal to the solid surface that the flow streamlines can be considered to have been displaced by virtue of the boundary-layer information.

3.2.2 *crest*—the horizontal plane surface of the weir.

3.2.3 *critical flow*—open channel flow in which the energy, expressed in terms of depth plus velocity head, is a minimum for a given flow rate and channel. The Froude number is unity at critical flow.

3.2.4 *Froude number*—a dimensionless number expressing the ratio of inertial to gravity forces in free surface flow. It is equal to the average velocity divided by the square root of the product of the average depth and the acceleration due to gravity.

3.2.5 *head*—*in this test method*, the depth of water above a specified elevation. The measuring head is the depth of flow above the weir crest measured at an appropriate location upstream of the weir; the downstream head is referenced similarly to the crest elevation and measured downstream of the weir. The head plus the corresponding velocity head is often termed the total head or total energy head.

3.2.6 *hydraulic jump*—an abrupt transition from supercritical flow to subcritical or tranquil flow, accompanied by considerable turbulence or gravity waves, or both.

3.2.7 *nappe*—the curved sheet or jet of water overfalling the downstream end of the weir.

3.2.8 *primary device*—the device (in this case, the weir) that creates a hydrodynamic condition that can be sensed by the secondary instrument.

3.2.9 *Reynolds number*—a dimensionless number expressing the ratio of inertial to viscous forces in a flow. The pertinent Reynolds number on the weir crest is equal to the (critical)

¹ This test method is under the jurisdiction of ASTM Committee D-19 on Water and is the direct responsibility of Subcommittee D19.07 on Sediments, Geomorphology, and Open-Channel Flow.

Current edition approved Sept. 15, 1994. Published November 1994.

² *Annual Book of ASTM Standards*, Vol 11.01.

³ Available from American National Standards Institute, 11 West 42nd St., 13th Floor, New York, NY 10036.

velocity multiplied by the crest length and divided by the kinematic viscosity of the water.

3.2.10 *secondary instrument*—*in this case*, a device that measures the depth of flow (referenced to the crest elevation) at an appropriate location upstream of the weir. The secondary instrument may also convert this measured head to an indicated flow rate or could totalize flow rate.

3.2.11 *stilling well*—a small free-surface reservoir connected through a restricted passage to the head-measurement location upstream of the weir so that a head measurement can be made under quiescent conditions.

3.2.12 *subcritical flow*—open channel flow that is deeper and at lower velocity than critical flow for the same flow rate; sometimes called tranquil flow. A Froude number less than one exists.

3.2.13 *submergence*—a condition in which the water level on the downstream side of the weir is high enough to affect the flow over the weir and hence alter the head-discharge relation. It is usually expressed as a ratio or percentage of downstream to upstream head or downstream to upstream total head.

3.2.14 *supercritical flow*—open channel flow that is shallower and at higher velocity than critical flow for the same flow rate. A Froude number greater than one exists.

3.2.15 *tailwater*—the water elevation immediately downstream of the weir.

3.2.16 *tranquil flow*—see *subcritical flow*.

3.2.17 *velocity head*—the square of the average velocity divided by twice the acceleration due to gravity.

4. Summary of Test Method

4.1 In broad-crested weirs, the length of the horizontal crest in the direction of flow is large enough relative to the upstream head for essentially rectilinear critical flow to occur at some point along the crest. This ideally permits the flow rate to be obtained from a single measurement of the upstream head; a corrective coefficient must be applied in practice. This coefficient has been evaluated experimentally for square-edge weirs and can be determined analytically for rounded weirs.

5. Significance and Use

5.1 Broad-crested weirs can be used for accurate measurements of a wide range of flow rates, but their structural simplicity and sturdiness make them particularly useful for measuring large flows under field conditions.

5.2 Because they require vertical sidewalls, broad-crested weirs are particularly adaptable to rectangular artificial channels or to natural and artificial channels that can readily be lined with vertical sidewalls in the immediate vicinity of the weir.

6. Interferences

6.1 Broad-crested weirs are not suitable for use in sediment-laden streams that are carrying heavy bed loads. However, floating debris is readily passed, particularly by the rounded weir (see 7.2.1).

6.2 Broad-crested weirs cannot be used beyond submergence limits because insufficient data exist to document their performance. It is therefore necessary to adhere to the tailwater-level limitations described in this test method.

7. Apparatus

7.1 A broad-crested weir measuring system consists of the weir itself and its immediate channel (the primary) and a head measuring device (the secondary). The secondary device can range from a simple staff gage for visual readings to an instrument that senses the depth continuously, converts it to a flow rate, and displays or transmits a readout or record of the instantaneous flow rate or totalized flow, or both.

7.2 *Square-Edge (Rectangular) Broad-Crested Weir:*

7.2.1 *Configuration*—The square-edge broad-crested weir as shown in Fig. 1 is rectangular in longitudinal profile and provides a plane horizontal crest that has finite length in the direction of flow and extends the full width of the channel between vertical sidewalls. A contracted section must be constructed as shown (see also 7.4.1.2) if the channel does not have vertical sidewalls or is wider than the desired crest. The vertical sidewalls must extend downstream of the downstream face of the weir a distance of at least twice the maximum head. Recommended limits on dimensions and geometric ratios are given in 7.2.5. The upstream and downstream faces must be vertical and perpendicular to the channel surfaces, and it is important that the upstream corner be square and sharp.

NOTE 1—High flow rates combined with floating debris may damage the sharp edge; rounded-edge weirs should be considered for such applications.

7.2.2 *Construction Requirements:*

7.2.2.1 The structure must be sturdy enough to withstand the maximum flow rate and must be watertight so that no measurable leakage can bypass it.

7.2.2.2 *Finish*—Large weirs constructed in the field should have a finish equivalent to that of smooth concrete. Smaller weirs, such as those in a laboratory environment, should have a smoothness equivalent to that of rolled sheet metal.

7.2.2.3 *Level*—The crest must not deviate from a level plane by more than 0.01 ft (2 mm) at any point or exceed a slope of 0.01 anywhere.

7.2.3 *Head Measurement Location*—Make the head measurement at a distance of 3 h to 4 h_{\max} upstream of the upstream face of the weir, where h_{\max} is the anticipated maximum head.

7.2.4 *Head-Discharge Relations:*

7.2.4.1 *Basic Equations*—The basic relation for the flow rate, Q , over a broad-crested weir is, in compatible units,

$$Q = (2/3)^{3/2} g^{1/2} C_v C_d B h^{3/2} \quad (1)$$

where:

h = measured upstream head referenced to the crest elevation,

B = width of the weir between the vertical side-walls,

g = acceleration due to gravity,

C_d = discharge coefficient that accounts for departures from ideal conditions, and

C_v = velocity-of-approach coefficient that permits the flow rate to be related to the measured head rather than the total head, H . Then,

$$C_v = (H/h)^{3/2} = [(h + \alpha V^2/2g)/h]^{3/2} \quad (2)$$

ASTM D 5614 – 94 (1998)

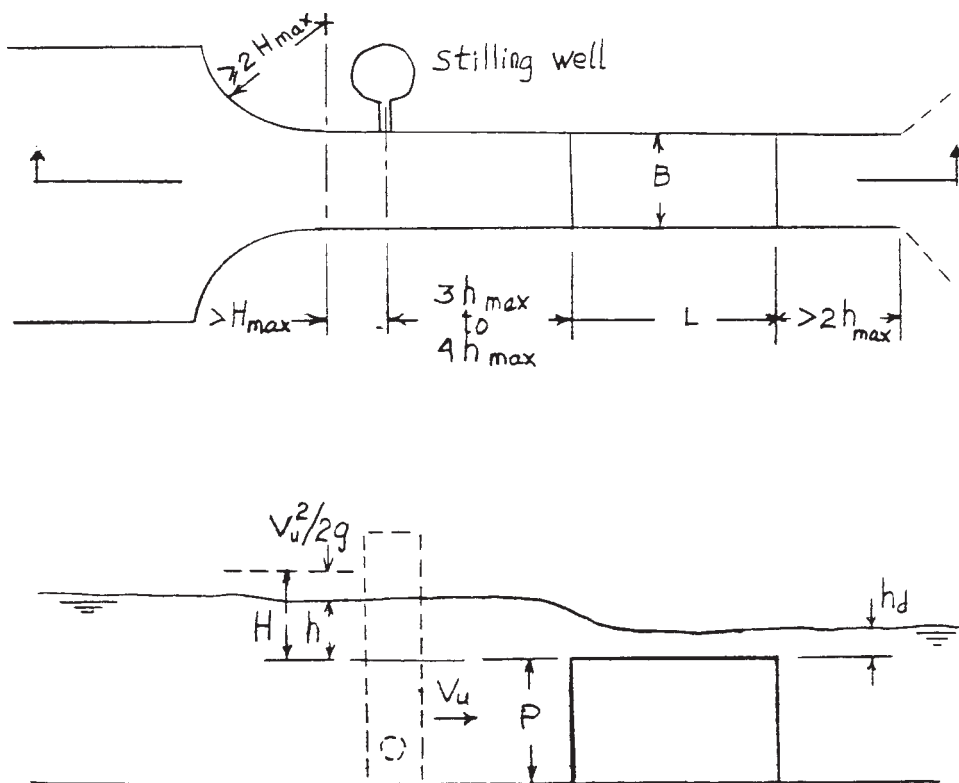

FIG. 1 Square-Edge Broad-Crested Weir

where:

V_u = average velocity at the head-measurement location, and

α = coefficient that accounts for any increase in the kinetic energy term caused by a nonuniform velocity distribution. However, in this test method, the approach velocity is considered sufficiently close to uniform (see 7.4.1) for α to be essentially unity.

7.2.4.2 In the case of square-edge weirs, both C_d and C_v are affected by the head-to-weir height ratio, h/P , so it is convenient to combine them into a single coefficient, C ; then,

$$Q = (2/3)^{3/2} g^{1/2} C B h^{3/2} \quad (3)$$

7.2.4.3 Discharge Coefficient, C :

(1) The discharge coefficient is given as a function of h/L and h/P in Fig. 2, which has been adapted from ISO 3846-1989.

(2) The discharge coefficient for $h/L \leq 0.3$ is constant at 0.850, provided that $h/P < 0.15$. (For $h/L > 0.4$, the weir is no longer truly broad crested in accordance with 4.1, since the flow over the crest is curvilinear throughout.)

7.2.5 Limiting Conditions—The flow conditions and dimensions of the square-edge weir are subject to the following limits:

- (1) $h > 0.2$ ft (0.06 m), or $0.1 L$, whichever is larger;
- (2) $B > 1$ ft (0.3 m);
- (3) $P > 0.5$ ft (0.15 m);
- (4) $0.1 < h/L < 1.6$;

(5) $h/P < 1.6$; and

(6) $0.1 < L/P < 4$.

The minimum h is recommended in order to minimize the effects of surface tension, viscosity, and surface roughness and to avoid small heads that may be difficult to measure accurately. The minimum h/L prevents frictional effects from causing the point of critical flow to shift away from the upstream end of the crest. The limitation on maximum h/P is intended to reduce the likelihood of upstream disturbances, and the remaining limitations are recommended mainly to conform to the experiments from which the coefficients were obtained. Limiting values of tailwater depth to avoid submergence are given in 7.4.2.2.

7.3 Rounded Broad-Crested Weir:

7.3.1 Configuration:

7.3.1.1 The rounded broad-crested weir is shown in Fig. 3. As in the square-edge weir, a plane level crest of finite streamwise length extends over the full channel width between vertical sidewalls. If the channel is not rectangular or of suitable width, construct a contracted section as shown. The upstream face must be vertical and perpendicular to the channel surfaces. However, the following geometric features depart from those of the square-edge weir.

7.3.1.2 To prevent separation round the upstream corner to a radius of at least $0.2 H_{max}$, where H_{max} is the anticipated maximum upstream total head.

NOTE 2—Sources customarily express rounded-weir dimensions in terms of total head, H . Users can place them in terms of measured head,

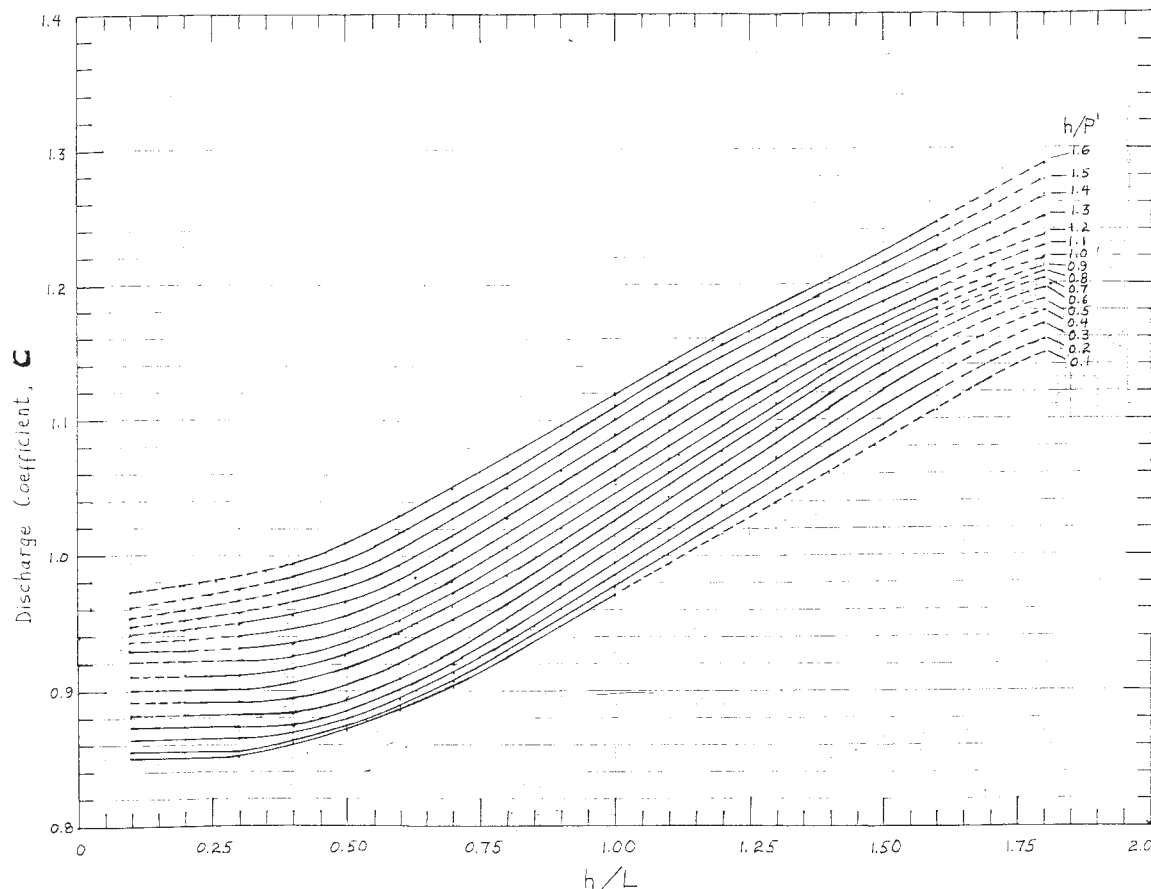

FIG. 2 Discharge Coefficients for Square-Edge Weirs (Dashed Portions of Curves Are Outside of the Recommended Limits)

h , by using (Eq 2) and Table 1. If H/P is limited to a maximum of 1.5 as recommended in 7.3.5, H/h will not exceed approximately 1.06.

7.3.1.3 The length of the horizontal part of the crest must be at least $1.75 H_{\max}$, and the total length (including radius) must be at least $2.25 H_{\max}$.

7.3.1.4 The downstream face of the rounded weir can be sloped rather than vertical; the only effect is on the tailwater depth necessary to avoid submergence (see 7.4.2.3).

7.3.2 Construction Requirements:

7.3.2.1 The watertightness and finish requirements for the rounded weir are the same as those for the square-edge weir given in 7.2.2.1 and 7.2.2.2.

7.3.2.2 Level—The crest of the rounded weir must be level within the slope of 0.001.

7.3.3 Head Measurement Location—Measure the head at a distance of $3 H$ to $4 H_{\max}$ upstream of the upstream face of the weir.

7.3.4 Head-Discharge Relations:

7.3.4.1 For rounded-edge weirs, the discharge coefficient, C_d , in Eq 1 is associated with frictional effects along the crest and may be expressed in terms of boundary layer growth as

$$C_d = [1 - (2\delta_* / L) (L/B)] [1 - (\delta_* / L) (L/h)]^{3/2} \quad (4)$$

where:

δ_* = boundary-layer displacement thickness.

The value of δ_* / L as a function of Reynolds number (see 3.2.9)

and relative surface roughness can be determined by methods given in ISO 4374-1990 and in fluid mechanics texts; however, unless the surfaces are excessively rough, it is sufficiently accurate to use $\delta_* / L = 0.003$ for relatively small and smooth weirs, as in a laboratory, and $\delta_* / L = 0.004$ for larger concrete weirs.

7.3.4.2 The velocity-of-approach coefficient, C_v , in Eq 1 is given in Table 1 as a function of $C_d B h / A_u$, where A_u is the cross-sectional area of the approach flow and is equal to $B(P + h)$.

7.3.5 Limiting Conditions—The flow conditions and dimensions of the rounded weir are subject to the following limitations:

- (1) $h \geq 0.2$ ft (0.06 m);
- (2) $0.05 \leq H/L \leq 0.57$;
- (3) $H/P < 1.5$;
- (4) $\rho \geq 0.5$ ft (0.15 m); and
- (5) $B \geq 1$ ft (0.3 m), $\geq H_{\max}$, and $\geq L/5$.

The minimum h is recommended in order to minimize the effects of surface tension and viscosity and to avoid small heads that may be difficult to measure accurately. The minimum H/L discourages the formation of surface waves along the crest and prevents excessive influence of surface roughness or other uncertainties on the determination of c_d . The limit on maximum H/L allows an assumption that curvature effects are insignificant in Eq 1. The remainder of the limitations are recommended mainly to conform to the database from which

ASTM D 5614 – 94 (1998)

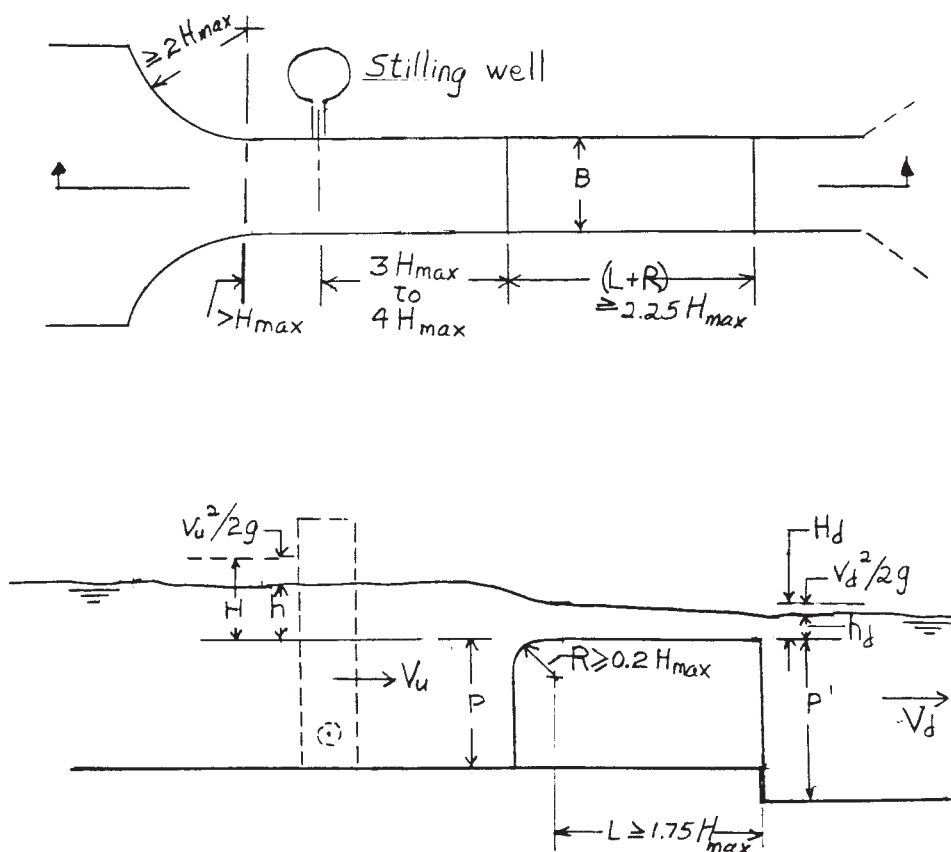

FIG. 3 Rounded Broad-Crested Weir

TABLE 1 Velocity-of-Approach Coefficients^A

$(C_d B h / A_u)$	C_v
0.1	1.002
0.2	1.009
0.3	1.021
0.4	1.039
0.5	1.064
0.6	1.098
0.7	1.146
0.8	1.218
0.9	1.340

^A Assumes $\alpha = 1.0$ (see 7.2.4.1).

experimental confirmation has been obtained. Also, excessively high H/P values may introduce upstream surface waves, and in no case should the approach Froude number (3.2.4) exceed 0.5. Limiting values of tailwater depth are given in 7.4.2.3.

7.4 Installation Conditions:

7.4.1 Approach Conditions:

7.4.1.1 The flow approaching the weir should be tranquil and distributed uniformly across the channel cross-section in order to satisfy the conditions of Eq 1 and of the experiments from which the database was obtained. For this purpose, define uniform velocity distribution as that associated with fully developed flow in a long, straight, moderately smooth channel. Straight, smooth approach lengths upstream of the head measurement location of ten times the maximum flow water surface width have been suggested for square-edge weirs (ISO 3846-1989) and five times the surface width for rounded weirs

(ISO 4374-1990) have been suggested; both lengths would have to be increased substantially in the presence of bends, turnouts, gates, etc. immediately upstream. In practice, however, there can be no universally accepted quantitative guidelines that will ensure a “uniform” velocity distribution, so the adequacy of the approach flow must be demonstrated on a case-by-case basis using measurements, experience with similar situations, or analytical approximations.

NOTE 3—Upstream bends, etc., close to the weir may affect not only the velocity distribution but also the water surface evaluation at the head measurement location.⁴

7.4.1.2 Where a channel contraction is necessary (Fig. 1 and Fig. 3), it must be conducted symmetrically with vertical walls curved at a radius of at least $2 H_{max}$, with the contraction ending tangent to the weir sidewalls at least $1 H_{max}$ upstream of the head-measurement location. The velocity distribution in accordance with 7.4.1.1 must prevail at the entrance to the contraction.

7.4.1.3 In debris-free flow, use baffles to bring the velocity distribution up to the requirements of 7.4.1.1, but they must be placed more than $10 H_{max}$ upstream of the head-measurement location.

7.4.1.4 The approach flow must be subcritical. If it is supercritical, form a hydraulic jump at least $30 H$ upstream of

⁴ Ackers, P., et al, *Weirs and Flumes for Flow Measurement*, John Wiley & Sons, New York, NY, 1979.

the head-measurement location to allow sufficient damping of surface waves to occur.

7.4.2 Downstream Conditions:

7.4.2.1 Do not operate broad-crested weirs under submerged conditions, that is, with the tailwater high enough to reduce the flow rate for a given upstream head. Limiting submerged conditions are given in the following paragraphs.

7.4.2.2 *Limiting Tailwater Elevation, Square-Edge Weirs*—The limiting ratio of downstream to upstream head, h_d/h , is a function of h/L . This ratio is 0.80 for $h/L \leq 0.3$; it decreases to approximately 0.60 at $h/L = 0.5$, to 0.40 at $h/L = 0.7$, to 0.24 at $h/L = 1.0$, and to 0.07 at $h/L = 1.6$.

7.4.2.3 *Limiting Tailwater Elevation, Rounded Weirs*—The limiting submergence ratio for rounded weirs is expressed as a ratio of downstream to upstream total head, H_d/H and is a function of H/P' , where P' is the height of the downstream face of the weir (if different from P). This ratio is 0.63 at $H/P' = 0.1$ and increases to approximately 0.75 at $H/P' = 0.5$ and to 0.80 for $H/P' \geq 1.0$. These ratios can be increased by approximately 0.05 if the downstream face of the weir is sloped at 1:5 (vertical:horizontal), in accordance with ISO 4374-1990.

7.4.2.4 Users should be aware of the possibility of increased downstream depths over time due to increased roughness or other changes in the channel. The installation of a downstream staff gage or other measuring device is recommended so that the submergence ratio can be calculated.

7.4.2.5 There should be no aeration of the nappe at the downstream end of a square-edge weir. (This condition is satisfied by the downstream extension of the side-walls specified in 7.2.1.)

7.5 Secondary System:

7.5.1 A minimal secondary system for continuous monitoring would contain a depth (head)-sensing device and an indicator or recorder from which the user could determine flow rates from the head-discharge relations. Optionally, the secondary system could convert the measured head to an indicated or recorded flow rate, or both, and also could transmit the information to a central location.

7.5.2 Continuous head measurements can be made with several types of sensors including, but not restricted to, the following: floats; pressure sensors, for example, bubble tubes and diaphragm gages; acoustic sensors; and electrical sensors, for example, resistance, capacitance, and oscillating probes.

7.5.3 Stilling Wells:

7.5.3.1 Stilling wells are recommended for accurate head measurements; they are required when float-driven recorders are used or when the water surface is rough.

7.5.3.2 The lateral area of the stilling well is governed partly by the requirement of the secondary instrument. For example, the clearance between a float and the wall of the stilling well should be at least 0.1 ft (2 cm) and should be increased to 0.25 ft (7.6 cm) if the well is made of concrete or other rough material, the float diameter itself being determined in part by permissible mechanical float lag error (see 11.5.3). Other types of sensors may also impose size requirements on the stilling well, and the maximum area may be limited by response lag. The depth of the stilling well must be sufficient to accommo-

date the anticipated range of head plus any sediment that may be deposited in the well.

7.5.3.3 The stilling well and its connection to the sidewall must be leakproof. Make provision for cleaning and flushing the well and connector pipe to remove any accumulated solids.

7.5.3.4 The opening in the channel sidewall connecting to the stilling well either directly or through a pipe must be at least 0.2 ft (0.06 m) below the minimum water level and have a perpendicular, flush, and burr-free junction with the wall. The wall should be smooth (equivalent to a smooth concrete) within a radius of at least 10 hole diameters around the center of the hole.

7.5.3.5 The proper size of the connector will depend on the particular situation, so specific diameters cannot be listed. It must be small enough to dampen surface disturbances effectively yet not so small that it introduces a time lag in the response or is difficult to keep open. For example, in relatively steady flows of clean water, diameters of 1/2 in. (1.3 cm) or even smaller may suffice, while more demanding field conditions such as a long connecting pipe may require a 3-in. (7.5-cm) or larger pipe. ISO 4374-1990 provides useful information on the sizing of connectors.

7.5.3.6 It is necessary to develop a method for referencing the stilling-well zero to the crest elevation.

8. Sampling

8.1 Sampling as defined in Terminology D 1129 is not applicable in this test method.

9. Calibration

9.1 An in-place calibration of the weir system is necessary if the design and installation conditions of Section 7 are not met. However, if those conditions are satisfied, calibration of the secondary system alone will suffice provided further that the estimated error for the standard weir coefficient in accordance with Section 11 is adequate for the purpose of the measurement. See also 9.3.

9.2 Calibrating the Secondary System:

9.2.1 To check the secondary instrument, it is necessary to make independent reference head measurements with a scale or preferable a point gage. Reference the zero of the scale or point gage to the elevation of the weir crest carefully. If the installation has a stilling well, make the reference measurement there for greatest accuracy. All measurements must be referenced to a common datum by engineering levels.

9.2.2 Compare the head indicated by the secondary instrument with the reference head (9.2.1). Repetition of this process over a range of heads will indicate whether zero adjustment is required. Repetition of individual measurements will provide information on the precision of the system.

NOTE 4—If the secondary readout is in terms of flow rate, the foregoing comparison must be made between the indicated flow rate and the flow rate computed using the reference head and the appropriate discharge equation of Section 7.

9.3 Calibrating the Complete System:

9.3.1 Methods for in-place calibration of the complete system include, but are not limited to, the following: velocity-area traverse, Practice D 3858; tracer dilution, ISO 555-1973; volumetric; and comparison with reference flow rate meter.

 **D 5614 – 94 (1998)**

9.3.2 Of the methods listed in 9.3.1, only the first three are likely to be usable in typical field situations. Full calibrations on-site are necessary when the weir system departs substantially from standard conditions or operates in a range subject to larger errors, for example, very low H/L in rounded weirs. Weirs used in the laboratory or under very controlled conditions require full calibrations.

10. Procedure

10.1 After initial calibration in accordance with 9.2 or 9.3, compare the secondary measurement daily with a reference measurement until an appropriate monitoring frequency can be established from the accumulated data.

10.2 Make routine equipment checks frequently at first, daily, in some cases, until a more appropriate frequency can be derived from the performance history. These checks include, but are not limited to, the following: secondary-sensor condition, surface condition, and elevation of the weir crest; condition of the sharp corner of square-edge weirs; zero elevation in the stilling well (particularly where there is a possibility of uneven subsidence of the structure); solids accumulation in the stilling well and connecting pipe; sediment accumulation upstream of the weir; and changes in the downstream channel that could affect submergence. In addition, perform routine maintenance on the secondary instrumentation as recommended by the manufacturer.

11. Precision and Bias

11.1 Determination of the precision and bias for this test method is not possible, both at the multiple and single operator level, due to the high degree of instability of open-channel flow. Both temporal and spatial variability of the boundary and flow conditions do not allow for a consent standard to be used for representative sampling. A minimum bias, measured under ideal conditions, is related directly to the bias of the equipment used and is listed in the following sections. A maximum precision and bias cannot be estimated due to the variability of the sources of potential errors listed in this section and the temporal and spatial variability of open-channel flow. Any estimate of these errors could be very misleading to the user.

11.2 In accordance with 1.6 of Practice D 2777, an exemption to the precision and bias statement required by Practice D 2777 was recommended by the Results Advisor and concurred with by the Technical Operations Section of the Executive Subcommittee on January 27, 1993.

11.3 *Total Measurement Error*—The error of a flow rate measurement results from a combination of the individual errors in the components of the discharge Eq 1 and Eq 3. The most important of these stem from uncertainties in the coefficients and in measurement of the head; the error in measurement of the weir width, B , is usually small and can be estimated readily by the user.

11.4 *Accuracy of the Coefficients:*

11.4.1 *Square-Edge Weirs*—The uncertainty in the coefficient C is $\pm 3\%$ for values of h/P up to 0.5. This uncertainty increases gradually to $\pm 4\%$ at $h/P = 1$ and to $\pm 5\%$ at $h/P = 1.6$.

11.4.2 *Rounded Weirs*—The uncertainty in the coefficient C_d is $\pm 3\%$ for $0.2 \leq H/L \leq 0.57$. For H/L between 0.05 and

0.2, the uncertainty (in percent) can be estimated from $\pm 2(21 - 20C_d)$, with the minimum not to fall below $\pm 3\%$ (absent an increase in α , the error in C_v should be negligible).

11.5 *Error in the Head Measurement:*

11.5.1 Errors in the measurement of head can make a large contribution to the total error (Eq 5), particularly at low heads, and it is important that the user make realistic estimates of the uncertainty in this measurement.

11.5.2 Regardless of the type of secondary device used, the error in referencing its zero to the weir crest will introduce an error that is constant in magnitude and therefore relatively more important at low flows.

11.5.3 All types of secondary devices, whether manual or automated, are subject to errors that are inherent in their use and that the user must estimate. For example, a staff gage placed on the channel sidewall is subject to reading errors due to water-surface disturbances and interpolation of the scale. The disturbances are eliminated if the gage is in a stilling well, but a restricted sight angle or inadequate lighting, or both, could introduce other uncertainties. Another example occurs in float systems, in which a significant error can be introduced by the float lag due to internal friction; estimate this error by measuring the friction torque and applying physical principles (and minimize it by the use of a large-diameter float). All contributions to the total error, from zero setting, sensor, recorder, etc., must be included in the total head-measurement error. However, a thorough calibration of the secondary system (9.2) provides information to assist the user in estimating some of the uncertainties. Other examples and information on head-measurement errors are available in other sources⁵ and ISO 4373-1979.

11.5.4 Some errors in head measurement can be minimized by careful maintenance (10.2). For example, grease coating may affect some types of wire probes, and acoustic devices may sense dense, foamy surfaces incorrectly. Also, users should be aware of the potential effect of crosswinds on the head measurement, especially in wide channels.

11.6 *Errors Due to Installation Conditions:*

11.6.1 *Approach Conditions*—Severely distorted upstream velocity profiles affect the coefficients and sometimes the head measurements. These errors generally cannot be quantified, and measuring stations exhibiting these characteristics must be calibrated in place to ensure accuracy.

11.6.2 *Downstream Conditions*—Errors due to submergences greater than those specified in 7.4.2.2 and 7.4.2.3 cannot be quantified, and these conditions should be avoided.

11.7 *Estimating the Total Measurement Error:*

11.7.1 One method of estimating the total percentage error of a flow measurement uses the square root of the sum of the squares of the individual error contributions. For example, for the standard weirs of Section 7, this becomes

$$e_t = [(e_1)^2 + (e_2)^2 + (1.5e_3)^2]^{1/2} \quad (5)$$

⁵ *Fluid Meters—Their Theory and Application*, 6th Ed., American Society of Mechanical Engineer, 1977.

 **D 5614 – 94 (1998)**

where:

- e_t = estimated total percentage error of a flow rate measurement,
- e_1 = estimated percentage error in the coefficient C or C_d ,
- e_2 = estimated percentage error in measurement of the weir width, B , and
- e_3 = estimated percentage error in the head, obtained by combining (square root of the sum of the squares) estimates of all individual components of the head-measurement error or by other means.

11.7.2 Equations similar to Eq 5 can be developed to include head-discharge relations obtained from in-place calibrations or to accommodate other error sources. Additional details on estimating total error can be found in ISO 4374-1990 and elsewhere.⁵

12. Keywords

12.1 dams; flumes; open-channel flow; streamflow

ASTM International takes no position respecting the validity of any patent rights asserted in connection with any item mentioned in this standard. Users of this standard are expressly advised that determination of the validity of any such patent rights, and the risk of infringement of such rights, are entirely their own responsibility.

This standard is subject to revision at any time by the responsible technical committee and must be reviewed every five years and if not revised, either reapproved or withdrawn. Your comments are invited either for revision of this standard or for additional standards and should be addressed to ASTM International Headquarters. Your comments will receive careful consideration at a meeting of the responsible technical committee, which you may attend. If you feel that your comments have not received a fair hearing you should make your views known to the ASTM Committee on Standards, at the address shown below.

This standard is copyrighted by ASTM International, 100 Barr Harbor Drive, PO Box C700, West Conshohocken, PA 19428-2959, United States. Individual reprints (single or multiple copies) of this standard may be obtained by contacting ASTM at the above address or at 610-832-9585 (phone), 610-832-9555 (fax), or service@astm.org (e-mail); or through the ASTM website (www.astm.org).