



Designation: D 4547 – 9803

Standard Guide for Sampling Waste and Soils for Volatile Organic Compounds¹

This standard is issued under the fixed designation D 4547; the number immediately following the designation indicates the year of original adoption or, in the case of revision, the year of last revision. A number in parentheses indicates the year of last reapproval. A superscript epsilon (ϵ) indicates an editorial change since the last revision or reapproval.

1. Scope

1.1 This guide describes recommended procedures for the collection, handling, and preparation of solid waste, soil, and sediment samples for subsequent determination of volatile organic compounds (VOCs). This class of compounds includes low molecular weight aromatics, hydrocarbons, halogenated hydrocarbons, ketones, acetates, nitriles, acrylates, ethers, and sulfides with boiling points below 200° Celsius (C) that are insoluble or slightly soluble in water.

1.2 Methods of sample collection, handling, storage, and preparation for analysis are described.

1.3 This guide does not cover the details of sampling design, laboratory preparation of containers, and the analysis of the samples.

1.4 It is recommended that this guide be used in conjunction with Guide D 4687.

1.5 *This standard does not purport to address all of the safety concerns, if any, associated with its use. It is the responsibility of the user of this standard to establish appropriate safety and health practices and determine the applicability of regulatory limitations prior to use. See 7.2 and 8.1.1 for specific warnings.*

2. Referenced Documents

2.1 *ASTM Standards:*

D 3550 Practice for Thick Wall Ring-Lined, Split Barrel, Drive Sampling of Soils²

¹ This guide is under the jurisdiction of ASTM Committee D34 on Waste Management and is the direct responsibility of Subcommittee D34.01.02 on Monitoring. Current edition approved ~~Sept. 10, 1998~~; 2003. Published ~~November 1998~~; August 2003. Originally published as ~~D 4547-91~~; approved in 1991. Last previous edition approved in 1998 as D 4547- ~~94~~8.

- D 4687 Guide for General Planning of Waste Sampling³
 D 4700 Guide for Soil Sampling from the Vadose Zone²
 D 5058 Test Methods for Compatibility of Screening Analysis of Waste³
 D 5792 Practice for Generation of Environmental Data Related to Waste Management Activities: Development of Data Quality Objectives³
 D 6051 Guide for Composite Sampling and Field Subsampling for Environmental Waste Management Activities³
 D 6418 Practice for Using the Disposable En Core Sampler for Sampling and Storing Soil for Volatile Organic Analysis³
 D 6640 Practice for Collection and Handling of Soils Obtained in Core Barrel Samplers for Environmental Investigations³
 E 856 Definitions of Terms and Abbreviations Relating to Physical and Chemical Characteristics of Refuse-Derived Fuel³
- 2.2 *Federal Standard:*
 Title 49 Transportation, Code of Federal Regulations (CFR), Part 172, List of Hazardous Substances and Reportable Quantities⁴

3. Terminology

- 3.1 *sample, n*—a portion of material taken from a larger quantity for the purpose of estimating properties or composition of the larger quantity. **(E 856)**
- 3.2 *subsample, n*—a portion of a sample taken for the purpose of estimating properties or composition of the whole sample. **(D 6051)**
- 3.2.1 *Discussion*—A subsample, by definition, is also a sample.

4. Summary of Guide

4.1 This guide addresses the use of tools for sample collection and transfer, conditions for sample storage, sample preservation, and two common means of sample preparation for analysis. Special attention is given to each step from sample collection to analysis to limit the loss of VOCs by volatilization ~~of and~~ biodegradation. The sample collected and analyzed should be representative of the parent matrix material sampled. The two methods cited for the preparation of samples for VOC analysis are methanol extraction and vapor partitioning (that is, purge-and-trap and headspace). The method of sample preparation for VOC analysis ~~is dependent on~~ should be consistent with the data quality objectives (see Practice ~~D 5792~~). ~~Although the equilibrium-driven proportions of VOC's in the different phases change during sample preparation and analysis, the overall intent of the methods in this guide are to minimize VOC losses.~~ D 5792).

5. Significance and Use

- 5.1 This guide describes sample collection and handling procedures designed to minimize losses of VOCs. The principal mechanisms for the loss of VOCs from materials during collection ~~and~~ handling and storage are volatilization and biodegradation. Susceptibility of various VOCs to these two loss mechanisms is both compound and matrix specific. In general, compounds with higher vapor pressures are more susceptible to volatilization than compounds with lower vapor pressures. Also, aerobically degradable compounds are generally more susceptible to biodegradation than anaerobically degradable compounds. In some cases, the formation of other compounds not originally present in the material ~~can occur~~. Loss or gain of VOCs leads to analytical results that are ~~both unrepresentative of the field conditions and ambiguous.~~ conditions.
- 5.2 Ancillary information concerning sample collection ~~and~~ handling and storage for VOC analysis is provided in Appendix X1 and Appendix X2. These appendixes and cited references are recommended reading for those unfamiliar with the many challenges presented during the collection ~~and~~ handling and storage of samples for VOC analysis.

6. Selection of Sample Preparation Method for VOC Analysis

6.1 Introduction:

- 6.1.1 Sample collection, handling, and preservation methods should be compatible with the method used to prepare the sample for VOC analysis, and meet the project's data quality objectives (see Practice D 5792). Preparation of a sample for instrumental analysis can be initiated either in the field or laboratory. In either case, prior to analysis, the sample should be placed into a tared volatile organic analysis (VOA) vial or bottle meeting the specifications given in ~~7.2.2. 7.3~~. When working with an uncharacterized solid waste, it is advisable to perform compatibility tests (see Test Methods D 5058) between the sample material and the solution (see ~~7.2.2.1 6.2 and 7.2.2.2 6.3~~) into which it will be transferred in preparation for analysis. For instance, when collecting highly contaminated soils or waste of unknown composition, ~~or both~~, it is strongly recommended that preliminary testing be performed to adequately characterize the waste materials so that when the user applies the procedures cited in this guide, there will be no chemical reaction which may jeopardize the user's safety.
- 6.1.2 Figs. 1 and 2 are flow diagrams showing some different options for combining sample collection, handling and preparation methods for instrumental analysis.

² Annual Book of ASTM Standards, Vol 04.08.

³ Annual Book of ASTM Standards, Vol 11.04.

⁴ Available from Superintendent of Documents, U.S. Government Printing Office, Washington, DC 20402.

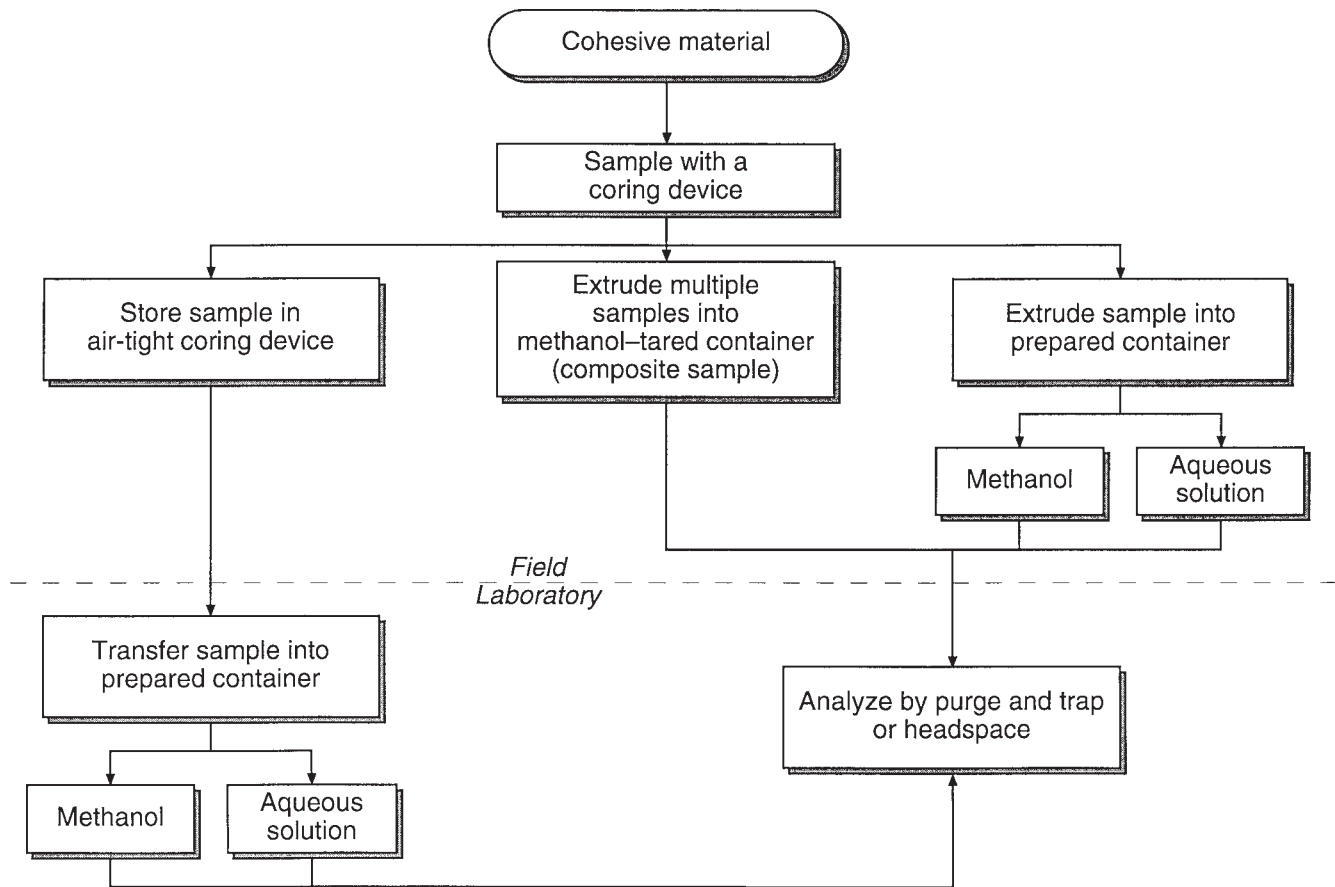

FIG. 1 Sample Handling Options for Cohesive Materials

6.2 Methanol Extraction:

6.2.1 This method involves the extraction of VOCs from a sample with methanol and the subsequent transfer of an aliquot of the extract to water for either purge-and-trap or headspace analysis.

6.2.2 Advantages of methanol extraction are (1) large samples or composite samples, or both, can be collected to enhance representatives (see Guide D 6051), (2) biodegradation is inhibited, (3) an efficient extraction of VOCs from the matrix materials can be achieved with methanol due to its strong affinity for these compounds and favorable wetting properties, (4) a subsample can be analyzed several times, and (5) sample extracts can be archived (held up to two months, and perhaps longer, archived, if verified that VOC losses have not occurred (see-8 10.2:1.21)).

6.2.2.3 The primary disadvantages of methanol extraction are (1) samples may have to be shipped as a flammable liquid depending on the amount of methanol present (for example, U.S. DOT reg. 49CFR§172.101), (2) hazards to personnel due to methanol’s toxicity and flammability, (3) detection limits are elevated due to analyte dilution, (4) possible interference of the methanol peak with VOCs of interest, (5) potential adverse impact of methanol on the performance of certain gas chromatograph/detector systems, and (6) in the United States of America, samples extracted with methanol must be disposed of as a regulated waste.

6.2.3 Some

6.2.4 Logistical challenges of performing these logistical-challenges tasks in the field can be overcome by extracting samples with methanol once they have been received in a laboratory, provided that the samples are transported intact and undisturbed in an airtight container (see-8 7.4:3.2, 9.1 and 9.2). Furthermore, if VOC levels are unknown, a replicate sample can be obtained and screened to determine if methanol extraction is appropriate for the expected contaminant concentrations.

6.3 Vapor Partitioning:

6.3.1 Vapor partitioning involves the direct analysis of a sample by either purge-and-trap or headspace. In both cases, the sample is placed into a tared volatile organic analysis (VOA) vial containing water or a preservative solution (for example, acidified water) from which the vapor is removed for analysis without the container being opened. Heat and water are usually used to assist with the partitioning of the VOCs from the sample. The opened.

6.3.2 The principal advantages of this method are (1) it can offer lower detection limits than methanol extraction because no dilution is involved, (2) there are no organic solvent interferences, and (3) there is no use of regulated organic solvents, which may require special shipment, disposal, and field handling practices.

6.3.2.3 The disadvantages associated with vapor partitioning are (1) the VOA vial (VOA vials are different sizes for automated

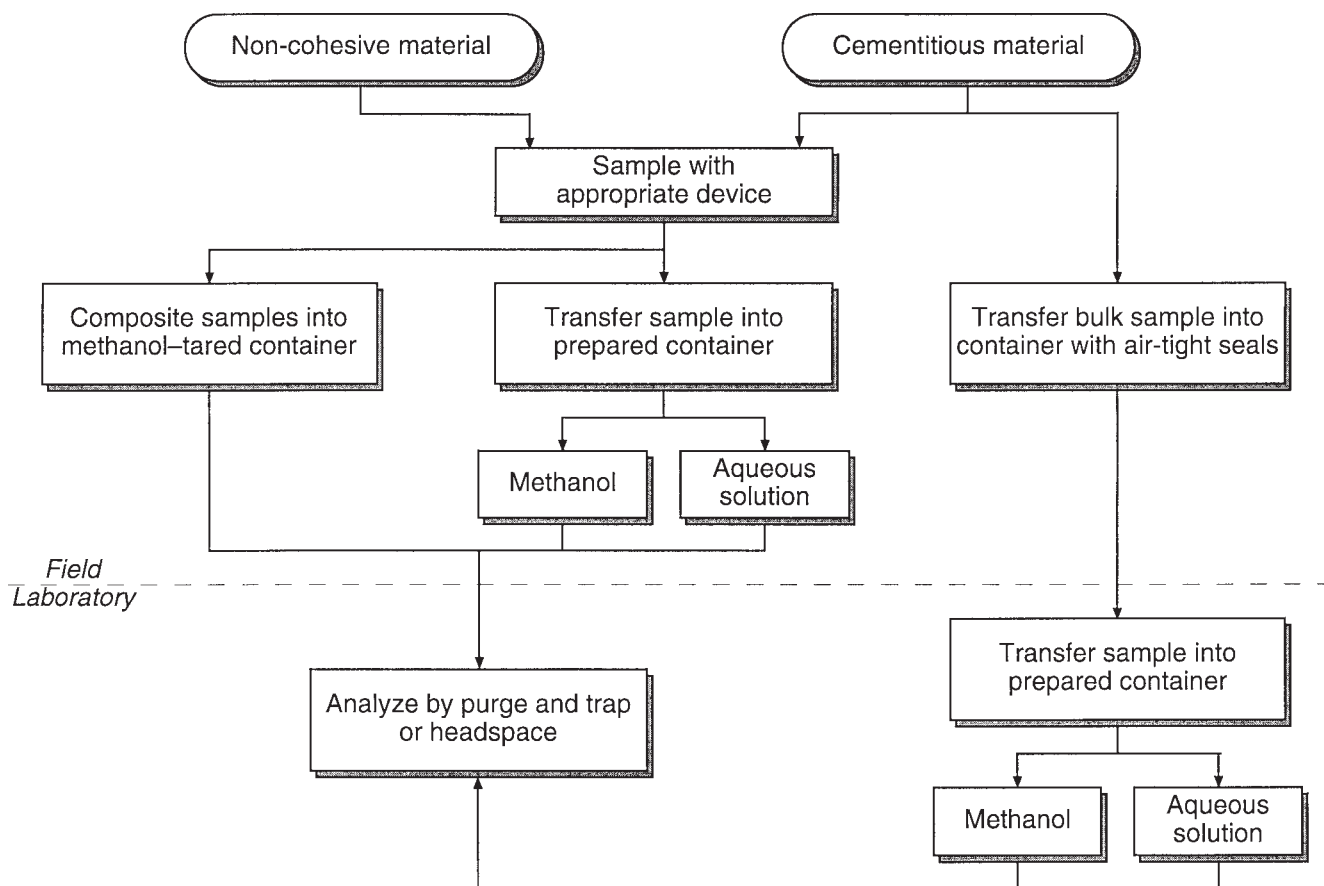

FIG. 2 Sample Handling Options for Non-Cohesive and Cementitious Materials

purge-and-trap and headspace instrumentation) or adapter used in conjunction with a VOA vial, or both, often are instrument specific, (2) sample size is limited (<10 g) by automated systems, (3) a matrix-appropriate method of preservation may be necessary (see Appendix X2), (4) vapor partitioning is less efficient at recovering VOCs from some materials than methanol extraction, and (5) when using purge-and-trap, only a single analysis of the same sample can be made; similarly only a single analysis may be possible with headspace analysis unless concentrations allow for the use of a small injection volume.

6.3.2.4 Limitations imposed by vapor phase partitioning methods with regard to number of analyses that can be performed on a single sample can be addressed by taking replicate samples.

6.3.35 When employing vapor phase partitioning methods, the logistical challenges of performing sample preparation in the field (see 7.2.2.2) 7.3.3) can be avoided by performing the preparation step in the laboratory, so long as the sample is transported to the laboratory intact and undisturbed, in an airtight container (see 8.1.1): 7.2.1). If VOC levels are unknown, a replicate sample can be obtained and screened to determine if it is appropriate to use of a vapor partitioning method of sample preparation.

7. Sample Collection

7.1 This section provides general sampling guidelines for a variety of materials Sampling Tools and conditions. The guidelines are intended Containers

7.1 All sample handling devices and vessels used to allow flexibility in the following:

7.1.1 The procedure collect and store samples for obtaining a sample from, for example, walls analysis should be constructed of test pits, surface grid locations, waste piles, building, nonreactive materials that will not sorb, leach or diffuse constituents of interest. Examples of materials that meet these criteria are glass, stainless steel, steel, and from bulk samples obtained with subsurface retrieval systems:

7.1.2 The design brass. Materials, such as polytetrafluorethylene (PTFE) and many rigid plastimecs also can be used, however, it should be recognized that they may have some limited adsorptive properties or allow slow diffusive passage of the equipment some VOCs. Materials which show limited reactivity can be used to obtain and transfer samples when they have a very short period of contact with the appropriate size sample or when they are necessary for analysis:

7.1.3 The selection making airtight (hermetic) seals. Collection tools and preparation storage containers made of materials other than those cited in this section should only be used after they have demonstrated equivalency. All collection tools and storage containers should be cleaned in a manner consistent with their intended use.

7.2 Preparation for Sampling:

7.2.1 All sampling and handling devices and vessels used to collect and store samples for analysis should be constructed of nonreactive materials that will not sorb, leach or diffuse constituents of interest. Examples of materials that meet these criteria are glass, stainless steel, and brass. Materials, such as polytetrafluorethylene and many rigid plastics also can be used, however, it should be recognized that they may have some limited adsorptive properties or allow slow diffusive passage of some VOCs. Materials which show limited reactivity can be used when they have a very short period of contact with the sample or when they are necessary for making airtight (hermetic) seals. Collection tools and storage containers made of materials other than those cited in this section should only be used after they have demonstrated equivalency. All collection tools and storage containers should be cleaned in a manner consistent with their intended use.

7.2.1.1 There are often several steps to sampling, particularly if it involves obtaining bulk materials from subsurface regions. Most of the equipment used to obtain samples from the subsurface was originally developed for the geotechnical industry. These subsurface bulk sample retrieval systems are designed to obtain intact cylindrical cores of material, ranging anywhere from 1 to 4 in. in diameter, and 1 to several ft in length. Two commonly used collection devices for subsurface sample collection are the split-spoon corer that opens to expose the entire length of the material obtained for subsampling and core barrel liners (that is, ring-lined barrel sampling, see Practice D 3550) that typically are subsampled through the open ends. Core barrel liners fit snugly within a corer and come in a variety of lengths and materials (stainless steel, brass, polytetrafluorethylene, PTFE, rigid plastics, etc.). Several liners, or a single long liner, can be placed within the core barrel, depending on the sampling plan (See **Warning** at the end of this paragraph). Additional information on the application and design of different types of subsurface collection systems available can be found in Guide D 4700. Subsurface materials retrieved for VOC characterization should be obtained (sampling tubes filled and brought to the surface) as quickly as possible and remain intact and undisturbed until they are subsampled (see Practice D6640). Subsampling of a bulk sample should occur within a couple of minutes of its being brought to the surface (see 7.3 8.1 through 7.6 8.3 for additional sampling guidance). (**Warning**—Core barrel liners are not recommended for storage of samples intended for VOC analysis because they do not have airtight seals (see Appendix X1).)

7.2.1.2 In addition to the coring devices which retrieve bulk quantities of material, there are smaller hand operated coring tools for obtaining samples of the appropriate size (for example, 5 coring devices capable of collecting 3- and 25-g) 15-cm³ volumes, for collection of approximately 5- and 25-g samples, respectively) for analysis (see Fig. 3). If one of these smaller coring devices is used to store the sample (see 8 9.1.1) for more than a few seconds, the main body should be constructed of materials that are nonreactive and have airtight seals that show limited sorption and penetration of VOCs. When the coring device is only used to rapidly transfer the sample to a VOA vial, corer material requirements are less stringent.

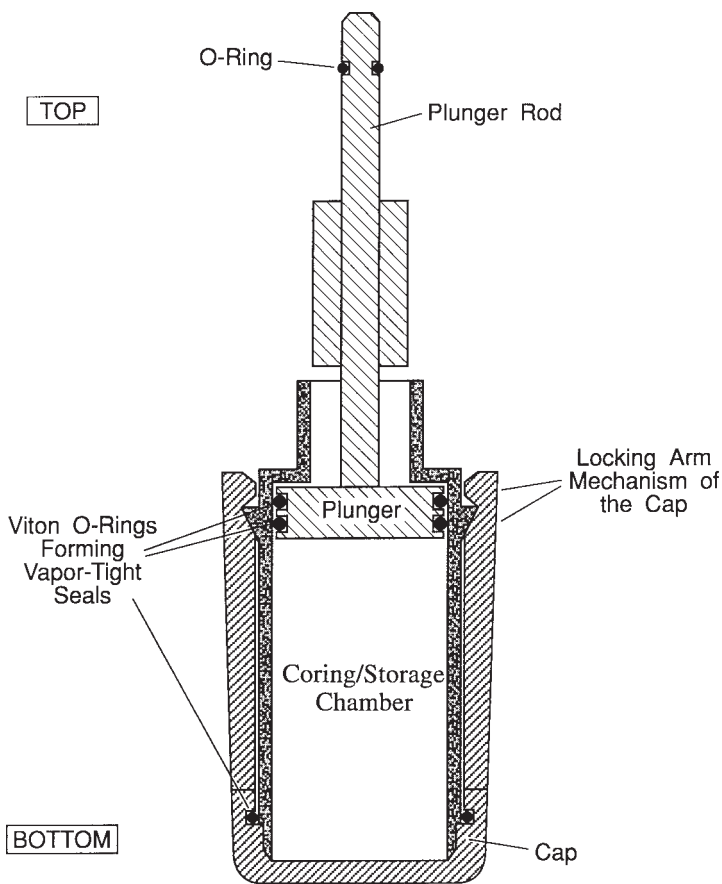

FIG. 3 Components of the En Core Sampler

7.2.2 VOA

7.3 Containers—VOA vials and bottles used for storage and preparation of samples for analysis should be made of glass and have airtight seals. To achieve ~~and an~~ airtight seal, these containers should have a thick septum cushion between the sealing material (~~polytetrafluoroethylene~~) (PTFE) and cap (rigid plastic screw cap or aluminum crimp top). ~~Polytetrafluoroethylene-lined PTFE-lined caps that do not have flexible septum backing often fail to achieve a liquid or airtight seal. Furthermore, the thickness of the polytetrafluoroethylene PTFE used for a lined septum, should be at least 10 min. These mil.~~

7.3.1 Preparation of VOA vials and bottles should be prepared as described in 7.2.2.1 Vial or 7.2.2.2 Bottle— Record the tared weight of the VOA vial or bottle and cap prior to adding the sampling event. Moreover, depending on the method of sample preparation and analysis, the vessel may also contain a solvent, or VOC free water, and if required a PTFE or glass coated stir bar at the time of sample collection (see Section 9).

7.2.3.1 Preparation of Containers for Methanol Extraction—~~Container preparation applies to both field and laboratory sample preparation.~~ The appropriate volume of analytical-grade methanol (high- performance liquid chromatography, spectrographic or spectrographic) ~~purge and trap~~ is added to the organic-free container by the laboratory that supplies the container, by the sample collector, or by a third party. The party that adds the methanol to the container should also be responsible for providing trip blanks and introducing surrogate compounds (see Guide D 4687). ~~Once If methanol has been placed is present in the sample container in the field, this container should be opened only to add the sample(s) and to remove aliquots for analysis: sample(s).~~ The tared weight of the container with methanol should be recorded prior to adding the sample to the container. A predetermined volume of sample is added to the methanol. This sample volume that corresponds to a weight in grams (g) that is equivalent to or less than the volume (mL) of methanol can then be introduced. The ratio (typically 1:1 to 10:1, methanol to material) between the two constituents should allow for formation of a clear layer of methanol over the sample after thorough mixing. The difference in weight of the container and cap, measured before and after the sample is introduced, is used to establish the sample's wet weight. Because of the water (moisture) present in most samples, calculation of the recovery of surrogate concentrations in the sample ~~analyte concentrations~~ should account for this source of dilution. **NOTE 1**—Initially the concentration of the surrogates is influenced only by the volume of methanol. After adding a sample, however, the liquid volume is increased by the volume of water present in the soil sample. The increased liquid volume results in a reduction in the surrogate concentration due to its dilution effect. After the moisture content of a sample is known, the expected surrogate concentration can be determined by multiplying the original surrogate concentration by: volume of methanol/total liquid volume.

7.2.2.2

7.3.3 Preparation of Containers for Vapor Partitioning—~~Container preparation applies to both field and laboratory sample preparation.~~ This method allows for the direct analysis of a sample by either purge-and-trap or headspace techniques. In both cases, the sample is placed into a VOA vial from which the vapor (only a portion for headspace analysis) is removed for analysis without the container being opened. Moreover, water that contains no detectable levels of VOCs is usually and if required a PTFE or glass coated stir bar should be present in the VOA vial prior to introducing the sample. Current automated equipment for purge-and-trap and headspace systems use 44- (or 40-) and 22-mL VOA vials, respectively. The volume of water used for these two different systems is typically 10 mL or less. ~~The addition of surrogate compounds and matrix spikes to samples prepared for vapor partitioning analysis can be problematic. Adding surrogates or matrix spikes (see Guide D 4687) to an open sample container prior to or immediately after sample collection can potentially result in Furthermore, the loss of VOCs from the VOA vial. A procedure for introducing surrogates or spikes that is less susceptible to VOC losses, can be performed by puncturing the septum with a needle (small gauge if done manually) after the sample has been sealed inside the container. If aromatic compounds are of concern and the sample will be held for more than 48 h before analysis, some form of chemical preservation in addition to refrigerated (4°C) storage should be used (see 8.2.2.2). When carbonates are not present, chemical preservation for aromatic compounds can be achieved by acidification to a pH of 2 or less with either sodium bisulfate or hydrochloric acid (for general guidance on testing for carbonates and the use of these acids to preserve samples, see Appendix X3). Precautions must be taken when preserving by acidification since certain compounds within the following classes: olefins, ketones, esters, ethers, and sulfides, will react under a low pH condition. Water, and if necessary, a chemical preservative, should be added to the sample container prior to adding the sample. Furthermore, the tared weight of the container should be recorded prior to adding the sample. The difference in weight of the container, measured before and after the sample is added, is used to determine the sample's wet weight. NOTE 2—Promising alternative methods~~

7.3.4 Preparation of preservation that may be considered when a low pH is undesirable Samples Transported and Stored in Solventless VOA Vials or carbonates Bottles—When samples are present and longer holding times held in a VOA vial or bottle, methanol can not be avoided; to the container by piercing the septum. In the case of a 5-g sample contained in Appendix X1 a 40-mL VOA vial, 5.0 mL of methanol can be added without over pressurization. When larger samples and Appendix X2:

7.2.3 A separate collocated sample bottles, or both, are used, experimental trials should be collected within a couple centimeters and from the same stratum performed to determine percent moisture content so that analyte concentration establish what volume of solution can be expressed on added. If performed manually, a dry weight basis. The location adjacent 23-gage or smaller needle should be used to where add the methanol. After the methanol is introduced, the soil sample for VOC analysis was removed should be inspected visually dispersed. If the sample is held beyond the laboratory-prescribed extraction and its characteristics logged. This adjacent material can also analysis period (typically 24 h or less), it is recommended that either the pierced septum be replaced

with one that is intact or that an aliquot of the methanol be transferred to an appropriate vessel for determining other relevant properties, such as general appearance, color, presence storage. If the pierced septum is replaced, it should be replaced with one that is intact by replacing the cap of the vial or bottle with a cap having an intact septum. When the laboratory prescribed extraction method uses elevated temperatures, or sonication, or both, it is recommended that the pierced septum be replaced prior to this treatment. To limit the loss of contamination, grain-size distribution, organic carbon content, etc. Collection VOCs when replacing the cap or transferring an aliquot of methanol, the container should be cooled to $4 \pm 2^\circ\text{C}$, and these ancillary samples functions should be performed after as quickly as possible. Cooling the sample lowers the vapor pressure of the analytes of interest and reduces the pressure created by adding the methanol. By having methanol present in the collection vessel prior to introducing the sample, the additional precautions associated with a pierced septum can be avoided. In addition, having methanol present in the collection vessel reduces the possibility of samples for VOC analysis.

7.3 VOCs being lost during the transfer step (that is, extrusion of a plug of soil from the sampling tool into the empty vessel.)

8. Sample Collection

8.1 *General Sampling Guidance*—After a fresh surface is exposed to the atmosphere, the sample collection process should be completed in a minimal amount of time. Removing a sample—Using an appropriate sized coring tool (see below), collect samples from a material should be done with at least amount of disruption (disaggregation) as possible. Additionally, rough trimming of the sampling location's surface layers should be considered if the material may have already lost VOCs (been freshly exposed for more than a couple surfaces of minutes) the soil or if it may be contaminated by other waste, different waste with minimal disturbance. The soil strata, or vegetation. Removal of surface layers can waste to be accomplished by scraping sampled may be an intact pit face or the surface using relatively undisturbed contents of a clean spatula, scoop, knife, split-barrel sampler or shovel.

7.4 *Sampling a core barrel liner. Before sampling, remove several centimeters of Cohesive but Uncemented Materials Using Devices Designed material to expose a fresh surface. Obtain a Sample Appropriate for Analysis:*

7.4.1 Samples of the appropriate size for analysis should be collected using a metal or rigid plastic coring tool (Fig. 3). For example, coring tools for the purpose of transferring a sample can be made from disposable plastic syringes by cutting off pressing (or hammering in a few cases) the tapered front end and removing of the rubber cap from the plunger (see Note 3). These smaller coring devices help maintain tool into the sample structure during collection and transfer to pit face or into the VOA vial end or side of a larger bottle, as do their larger counterparts used to retrieve subsurface materials. When inserting a clean coring tool into a fresh surface for sample collection, air should not be trapped behind the core sample. If air is trapped, it could either pass through Remove the sampled material causing VOCs to be lost or cause the sample to be pushed prematurely from the coring tool. For greater ease in pushing coring tools into the solid matrix, their front edge can be sharpened. The optimum diameter of the coring tool depends on the following: size of the opening on the collection vial or bottle (tool should fit inside mouth), particle size of the solid materials (for example, gravel-size particles would require larger samplers), and volume of sample required for analysis. For example when a 5-g sample of soil is specified, only a single 3-cm³ volume has would need to be collected (assuming the soil has density of 1.7 g/cm³). Larger sample masses or composite samples may be preferred as the heterogeneity of the material increases. Note 3—**Caution:** This coring device is not appropriate for sample storage.

7.4.2 An undisturbed sample is obtained by pushing the barrel of the coring tool into a freshly exposed surface and removing the corer once filled. The exterior of the barrel should be quickly wiped with a clean disposable towel. If the coring tool is used as a storage container, cap the open end after ensuring that the sealing surfaces are cleaned (see 8.1.1). If the device is solely used for collection and not storage, immediately extrude the sample into a tared VOA vial or bottle by gently pushing the plunger. During transfer of the sample into the container, care should be taken to prevent the sample from contacting the sealing surfaces which can comprise these surfaces and prevent an airtight seal. The volume of material collected should not cause excessive stress on the coring tool during intrusion into the material, or be so large that the sample easily falls apart during extrusion. Obtaining and transferring a sample should be done rapidly (<10 s) to reduce volatilization losses. If the vial or bottle contains methanol or another liquid, it should be held at an angle when extruding the sample into the container to minimize splashing. Just before capping, a visual inspection of the lip and threads of the sample vessel should be made, and any foreign debris should be removed with a clean towel, allowing an airtight seal to form.

7.5 *Devices that Can be Used for Sampling a Cemented Material:*

7.5.1 Samples of hard or cementitious material may be obtained by fragmenting a larger portion of the material using a clean chisel to generate aggregate(s) of a size that can be placed into a VOA vial or bottle. When transferring the aggregate(s), precautions must be taken to prevent compromising the sealing surfaces and threads of the container. Losses of VOCs by using this procedure are dependent on the location of the contaminant relative to the surface of the material being sampled. Therefore, caution should be taken in the interpretation of the data obtained from materials that fit this description. As a last resort when this task can not be performed on-site a large sample can be collected in a vapor-tight container and transported to the laboratory for further processing (see 8.1.2). Collecting, fragmenting, and adding the sample to a container should be accomplished as quickly as possible.

7.6 *Devices that Can be Used for Sampling a Noncohesive Material:*

7.6.1 When sampling gravel, or a mixture of gravel and fines, that can not be easily obtained or transferred using coring tools, as a last resort, a sample can be quickly transferred using a spatula or scoop (see discussion concerning the use of a spatula or scoop to collect samples for VOC analysis, in Appendix X1). Typically the collection vial or bottle will contain methanol or an aqueous

solution, therefore, samples should be dislodged with minimal splashing and without the spatula or scoop contacting the liquid contents. For some solids, a wide-bottom funnel or similar channeling device may be necessary to facilitate transfer to the container and prevent compromising of the sealing surfaces of the container. Caution should be taken in the interpretation of the data obtained from materials that fit this description. Losses of VOCs are likely because of the nature of the sampling method and the noncohesive nature of the material exposes more surface area to the atmosphere than for other types of samples. Another potential source of error during the sampling process, is the separation of coarser materials from fines, which can bias the concentration data if the different particle sizes, which have different surface areas, are not properly represented in the sample.

8. Sample Handling

8.1 Storage:

8.1.1 *Material Stored in Coring Device*—If the coring device also serves as Sampling of Cohesive but Uncemented Materials Using Devices Designed to Obtain a shipping container, it should have air tight seals. Presently the En-Core⁵ sampler, which is available Sample Appropriate for the collection, storage and transfer of approximately 5 and 25 g samples, is the only commercially available Analysis—Collect appropriate size sample for analysis using a metal or rigid plastic coring device that has been specifically designed to meet this requirement (see Fig. 4 tool (Figs. 3 and 4)). For example, coring tools for the purpose of transferring a sample can be made from disposable plastic syringes by cutting off the tapered front end and removing the rubber cap from the plunger (see **Warning** at the end of this paragraph). These smaller coring devices help maintain the sample structure during collection and transfer to the VOA vial or a larger bottle. When inserting a clean coring tool into a fresh surface for sample collection, air should not be trapped behind the sample. If air is trapped, it could either pass through the sampled material causing VOCs to be lost or cause the sample to be pushed prematurely from the coring tool. For greater ease in pushing coring tools into the solid matrix, their front edge can be sharpened. (**Warning**—This type of coring device is not appropriate for sample storage.)

8.1.2 Obtain an undisturbed sample by pushing the barrel of the coring tool into a freshly exposed surface and removing the

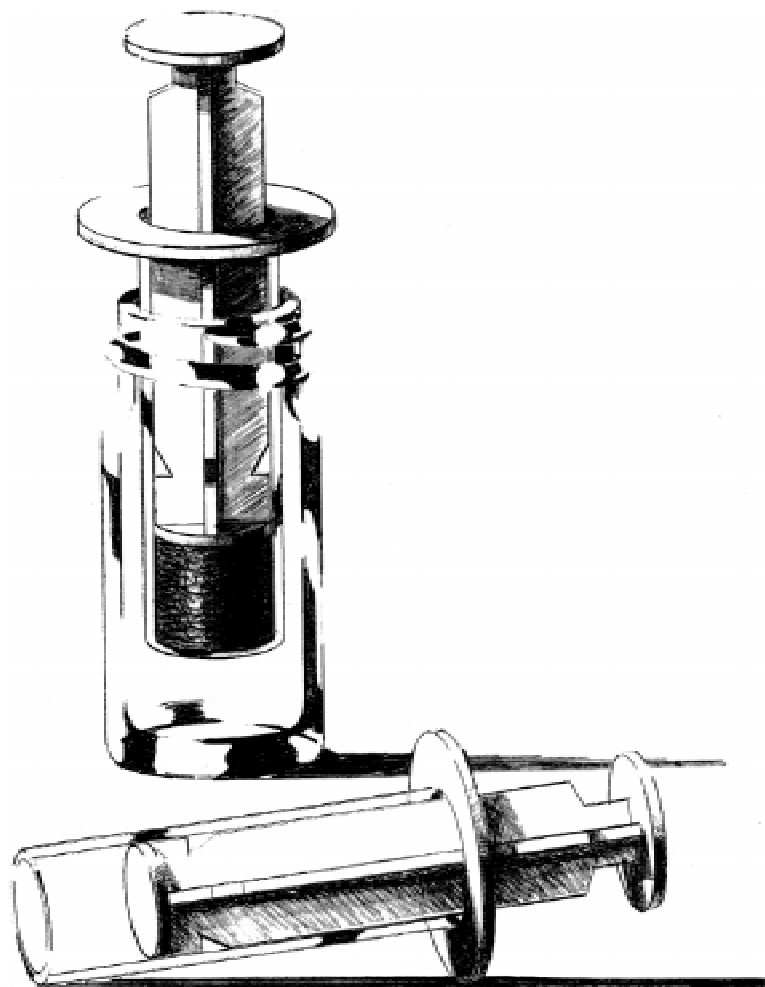

FIG. 4 A Coring Tool Made by Cutting the Tip Off a Plastic Syringe

corer once filled. Clean the exterior of the barrel by wiping with a clean disposable towel. If the coring tool is an En Core⁵ sampler and it is used as a storage container, cap the open end after ensuring that the sealing surfaces are cleaned (see 9.1.1). If the device is solely used for collection and not storage, immediately extrude the sample into a tared VOA vial or bottle by gently pushing the plunger. During transfer of the sample into the container, care should be taken to prevent the sample from contacting the sealing surfaces which can comprise these surfaces and prevent an airtight seal. The volume of material collected should not cause excessive stress on the coring tool during intrusion into the material, or be so large that the sample easily falls apart during extrusion. Obtaining and transferring a sample should be done rapidly (<10 s) to reduce volatilization losses. If the vial or bottle contains methanol or another liquid, it should be held at an angle when extruding the sample into the container to minimize splashing. Just before capping, a visual inspection of the lip and threads of the sample vessel should be made, and any foreign debris should be removed with a clean towel, allowing an airtight seal to form.

8.2 Devices That Can be Used for Sampling a Cementitious Material—Samples of hard or cementitious material may be obtained by fragmenting a larger portion of the material using a clean chisel to generate aggregate(s) of a size that can be placed into a tared VOA vial or bottle. When transferring the aggregate(s), precautions must be taken to prevent compromising the sealing surfaces and threads of the container. Losses of VOCs by using this procedure are dependent on the location of the contaminant relative to the surface of the material being sampled. Therefore, caution should be taken in the interpretation of the data obtained from materials that fit this description. As a last resort when this task can not be performed on-site, a large sample can be collected in a vapor-tight container and transported to the laboratory for further processing (see 9.1 and 9.2). Collecting, fragmenting, and adding the sample to a container should be accomplished as quickly as possible.

8.3 Devices That Can be Used for Sampling a Noncohesive Material—When sampling gravel, or a mixture of gravel and fines, that can not be easily obtained or transferred using coring tools, as a last resort, a sample can be quickly transferred using a spatula or scoop (see discussion concerning the use of a spatula or scoop to collect samples for VOC analysis, in Appendix X1). If the tared collection vial or bottle contains methanol or an aqueous solution, transfer the sample to the vial or bottle with minimal splashing and without the spatula or scoop contacting the liquid contents. For some solids, a wide-bottom funnel or similar channeling device may be necessary to facilitate transfer to the container and prevent compromising of the sealing surfaces of the container. Caution should be taken in the interpretation of the data obtained from materials that fit this description. Losses of VOCs are likely because of the nature of the sampling method and the noncohesive nature of the material exposes more surface area to the atmosphere than 48 h at $4 \pm 2^\circ\text{C}$ prior for other types of samples. Another potential source of error during the sampling process, is the separation of coarser materials from fines, which can bias the concentration data if the different particle sizes, which have different surface areas, are not properly represented in the sample.

8.4 Sampling Location Physical Characteristics—Collect a separate co-located sample within a couple of centimeters and from the same stratum and place in a suitable container for the determination of percent moisture content of the waste or soil. This sample should be collected in a container suitable for the retention of soil moisture. The location adjacent to preparing where the sample for VOC analysis was collected should be inspected visually and its characteristics logged. This adjacent material can also be retained for determining other relevant properties, such as general appearance, color, presence of oils, other visible signs of contamination, grain-size distribution, organic carbon content, etc. Collection of these ancillary samples should be performed after the collection of samples for VOC analysis.

9. Sample Storage, Transportation, and Preservation

9.1 Sample Storage and Transportation :

9.1.1 General Considerations—During an initial 48 h storage and transportation period, all samples for VOC analysis should be held in air-tight containers and cooled to at least $4 \pm 2^\circ\text{C}$.⁶ Refer to Appendix X2 for additional information concerning coring devices used as For storage and shipping containers.

8.1.2 Material Not Stored in Coring Device—To retard volatilization and biodegradation, samples transferred to a prepared VOC periods beyond 48 h, these air-tight containers (for example, VOA vial or bottle (see 7.2.2), whether preserved or not, En Core sampler [see Note 1]), should be cooled to $4 \pm 2^\circ\text{C}$ as soon as possible.

8.1.2.1 If contain a chemical preservative is not present, then samples should or be held under this condition for no longer than 48 h prior to analysis. conditions that ensure retention of the analytes of concern (see 9.2).

NOTE 4—If the sample is stored in the 1—The disposable En Core sampler is a coring device for 48 h, it should be analyzed promptly or preserved collection, storage, and transfer of soil samples. This device meets the specifications discussed in methanol or chemically preserved (for example, acidified) during 7.2.1 and 8.1.1. Guidance on the sample preparation step:

8.1.2.2 Chemically preserved (for example, acidified) subsamples awaiting vapor partitioning methods use of analysis should be analyzed as soon as possible and should not be stored for more than 14 days before analysis.

8.1.2.3 When samples are preserved by immersion in methanol, the holding period can be extended beyond the typical 14-day period, to up to two months, and perhaps longer, if verified (for example, demonstrated that no VOC losses occurred (see 8.2.1.2)).

⁵ En Core sampler, En Novative Technologies, Inc., 1241 Bellevue St, Green Bay, WI 54302. The En Core sampler is covered by a patent. Interested parties are invited to submit information regarding the identification of an alternative(s) to this patented item to the ASTM Headquarters. Your comments will receive careful consideration at a meeting of the responsible technical committee, which you may attend.

⁶ SW-846, Method 5035, 3rd Update.

8.2- En Core sampler is given in Practice D 6418.

9.2 Sample Preparation for Analysis Preservation Beyond 48 Hours:

9.2.1 Currently, it is recommended that samples stored in an air-tight container should be held for no longer than 48 h at 4 ± 2°C prior to analysis or preservation. Longer storage times at 4 ± 2°C can be applied if it can be demonstrated that the VOC concentrations are not affected or that the data generated at the time of analysis meets the data quality objectives. Extended sample storage can be achieved by using either physical or chemical methods of preservation. Sample preservation can be initiated at the time of sample collection or after arrival in a laboratory.

9.2.2 Physical Preservation—Samples contained in a VOA vial, a bottle, or coring device are physically preserved by low temperature storage (for example, preferably in a freezer set for -12 ± 5°C, or by using a temporary refrigerant, for example, a mixture of salt and ice or dry ice, see Appendix X2). Under this condition, sample storage (total time period starting at collection) can be extended up to 14 days. Longer periods of low temperature storage can be used provided it can be demonstrated that the VOC concentrations are not affected or that the data generated at the time of analysis meets the data quality objective. When low temperature storage is used for samples intended for analysis by vapor partitioning, VOC free water and if required a PTFE or glass coated stir bar should be present prior to adding the sample in the field (see 7.3.3). Special precautions may be necessary, for example, positioning the sample vessel on its side, when using a low temperature condition with VOA vials smaller than 40 mL, or when more than 5 mL of water is present, because of the potential for breakage caused by the formation of ice. When the sample is intended to be prepared by methanol extraction, this solvent can be introduced through the septa of the storage vessel after low temperature storage (see 7.3.4). In either case, immediately following low temperature storage of samples in VOA vials or bottles, the caps should be checked and tightened, if necessary. For the En Core sampler, the sample is extruded into a prepared VOA vial after low-temperature storage (see Practice D 6418).

9.2.3 Chemical Preservation—Samples immersed in methanol are chemically preserved. Under this condition, storage (total time period starting at collection) at 4 ± 2°C can be extended for up to 14 days. Longer periods of methanol preservation can be used provided if it can be demonstrated that the VOC concentrations are not affected or that the data generated at the time of analysis meets the data quality objectives. A chemical preservation method for samples intended to be analyzed by vapor partitioning, is acidification to a pH of 2 or less with either sodium bisulfate or hydrochloric acid. However, VOC samples containing carbonates should not be added to an acidic solution because of effervescence (for guidance on testing for carbonates and the use of these acids to preserve samples, see Appendix X3). Precautions must also be taken when preserving by acidification because certain compounds within the following classes; olefins, ketones, esters, ethers, and sulfides, will react under a low pH condition (see Appendix X2 for other potential problems). Acidified sample storage (total time period starting at collection) can be extended for up to 14 days at 4 ± 2°C. Longer periods of acidified sample storage can be used provided it can be demonstrated that the VOC concentrations are not affected or that the data generated at the time of analysis meets the data quality objectives.

10. Sample Preparation

10.1 Methanol Extraction:

8.2.1.1 Samples should be completely dispersed—Completely disperse samples in methanol, if possible (, by shaking, vortex mixing or sonication can be used), then allowed by sonication. Allow suspended particulates to settle so that an aliquot of clear supernatant can be removed for analysis. Some materials will show a slow release of VOCs to methanol; therefore, the dissolved VOC concentration may increase with increasing storage extraction time (see Appendix X1). This increased extraction of VOCs over time may be particularly pronounced with cementitious materials or materials that strongly adsorb VOCs. Vials and bottles containing methanol should always be stored upright and be allowed to reach room temperature before removing aliquots appropriate for analysis. Transfer of an aliquot for analysis should be performed using a clean liquid-tight syringe (composed of glass and metal) to withdraw the aliquot through the septum of the sample container. If necessary, the cap of the sample container can be removed, and an aliquot can be collected with either a clean glass syringe or pipette. However, the time that the cap is off the sample container should be minimized as much as possible to limit volatilization losses of solvent and VOCs. For purge-and-trap analysis, methanol aliquot volumes of less than 0.2 mL are typically transferred to a vessel containing 5 mL of organic-free water. For headspace analysis, methanol aliquot volumes as large as 1.0 mL, depending on the detector and analytes of concern, can be transferred to VOA vials containing 10 mL of organic-free water.8: When the re-analysis of the sample extract is a possibility, an aliquot of the extract should be archived by transferring it to an airtight vial (for example, 2 mL) with a PTFE-lined cap.

10.21.1 Periodic weighing of the sample container can be used to determine if a hermetic seal is being maintained, that is, no weight loss of methanol. Analysis of the surrogate compounds in the trip blanks (see Guide D 4687) can be used to establish whether containers chosen have an airtight seal.

8.2.2- methanol.

10.2 Vapor Partitioning:

8.2.2.1 Before being placed on the autosampler carousel, the sampled materials should be completely dispersed—Completely disperse samples in water, if possible (, by shaking, vortex mixing or sonication can be used); by sonication. This mixing of the solid material with the aqueous solution not only helps prevent the plugging of the sparging needle used by purge-and-trap systems but also assists in attaining an equilibrium state by completely exposing the sample to the partitioning solution. To enhance partitioning into the vapor phase, automated purge-and-trap and headspace analysis systems warm the sample to a selected

temperature (typically 40°C for purge-and-trap, this temperature or higher for headspace) prior to removing vapors for analysis.

~~8.2.2.2 Chemically preserved samples awaiting vapor phase partitioning analysis can show small losses of VOCs through the polytetrafluoroethylene-lined septum caps. For this reason, chemically preserved samples prepared for vapor partitioning methods of analysis should be analyzed as soon as possible and should not be stored for more than 14 days.~~

~~9.~~

11. Keywords

911.1 field sampling; methanol extraction; sample collection; sample handling; soil; solid wastes; vapor phase partitioning; volatile organic compounds

APPENDIXES

(Nonmandatory Information)

X1. ADDITIONAL INFORMATION CONCERNING SAMPLE COLLECTION AND HANDLING FOR VOC ANALYSIS.

X1.1 Volatile organic compounds (VOCs) are among the most frequently identified soil contaminants at Superfund and other hazardous waste sites. Because some VOCs are potentially mutagenic, carcinogenic, and teratogenic, they often are key factors in the risk assessment process at these sites. These risk assessments and other remedial decisions depend upon an accurate understanding of the levels and extent of VOC contamination in soils and other materials.

X1.2 In most materials, VOCs coexist as gaseous, liquid, and solid (sorbed) phases. The VOC equilibrium that exists among these phases is controlled by physiochemical properties, material properties, and environmental variables (1, 2).⁷ Unaccounted loss of analytes from any phase may result in rendering the sample unrepresentative of the material from which it was taken. For this reason, sample collection, handling, and analysis must be performed under conditions that maintain the accountability of all phases present (3).

X1.3 In general, uncontrolled losses of VOCs from materials occur through two mechanisms: volatilization and biodegradation. Volatilization losses occur whenever gaseous molecules, which have diffusion coefficients up to four orders of magnitude greater than liquid diffusion coefficients, are allowed to move freely. Therefore, whenever a new surface is exposed, VOC losses are incurred. The extent to which VOCs are lost depends on the vapor phase concentration (analyte vapor pressure), surface area exposed, duration of exposure, porosity of matrix, and perhaps meteorological conditions (4).

X1.4 Biological degradation of VOCs in samples is usually dominated by aerobic processes because many conventional intrusive collection methods expose the sample to the atmosphere. The rate of this biological degradation is dependent on several factors, including the indigenous microbiological population, chemical properties of the VOC, and temperature. Provided that sufficient quantities of electron acceptors, nutrients, and moisture are present, indigenous microbes continue to aerobically degrade compounds even when stored at 4°C (5). ~~A Non-halogenated aromatic compounds are quite susceptible to this loss mechanism. To inhibit biodegradation of these compounds, the sample can be immersed in methanol, frozen (see Appendix X2), or acidified to a pH of 2 or less, added to 20 mM (or greater) solution of cupric sulfate, or frozen to $-12 \pm 3^\circ\text{C}$ (applies to both samples dispersed in water within a partially filled container and samples held in a sealed En Core sampler). While the effectiveness of cupric sulfate and freezing on prohibiting microbiological activity is well known, the use of these two preservation methods with regard to samples held for VOC characterization, has not been documented. For this reason, these methods (preserving with cupric sulfate or freezing) should only be used when accompanied by a validation study. For cases where holding times of longer than 48 h are necessary and chemical preservation is not practical, the storage of samples in the En Core sampler at either $4 \pm 2^\circ\text{C}$ or $-12 \pm 3^\circ\text{C}$ is an option, provided it can be demonstrated that the longer holding periods used do not influence the VOC concentrations or that the data generated from the analysis of the samples meet the data quality objectives. Additional information concerning storage of samples in this type of coring device is further discussed in Appendix X2. less.~~

X1.5 ~~An example of a One~~ sampling procedure that fails to achieve accountability of all VOC phases is the collection of a bulk sample by using a spatula-type device to completely fill a bottle for sample storage and transportation (4, 6-10). Samples collected and transferred with spatula-type devices fail to control surface area exposure, for both cohesive and noncohesive materials. exposure. Moreover, in the process of filling a bulk sample bottle to capacity, the sealing surfaces often become compromised (dirty), preventing a vapor-tight seal during storage. For these reasons this procedure routinely results has been shown to result in concentrations that are less than 10 % of the in-situ contamination (6, 7-9-9).

⁷ The boldface numbers in parentheses refer to a list of references at the end of this standard.

X1.6 Another procedure that often performs poorly is the use of core barrel liners covered with either PTFE or aluminum foil for sample transportation and storage, because these barriers fail to serve as air-tight seals (3, 11). Sheets of PTFE that are only 2 or 3 mil (mil = 0.001 in.) thick are easily penetrated by VOC vapors. Elastic formulations of PTFE (for example, white plumber's tape) show much greater rates of VOC penetration than non-elastic semi-translucent formulations. Aluminum foil fails because an airtight seal is often not achieved when this material is folded over the end of a core barrel liner and it sometimes corrodes allowing small holes to form. The addition of plastic caps and sealing tape does not improve the performance of either PTFE or aluminum foil, since pliable plastics sorb VOCs and sealing tapes often contain VOCs in the adhesive, which serves as a potential artifact source.

X1.7 The procedures discussed in this guide are designed to limit VOC losses by volatilization and biodegradation. This is accomplished by stressing that (1) samples be collected only from freshly exposed surfaces, (2) collection and transfer of a sample be performed quickly and with minimal disruption to its physical state, (3) if possible, samples be held at $4 \pm 2^\circ\text{C}$ for not more than 48 h in an airtight vessel without taking (or initially including) additional preservation measures (chemical or perhaps freezing, particularly when aromatic compounds are under conditions that ensure retention of concern); the analytes of interest, and (4) and in the case of samples collected for vapor partitioning methods of analysis (purge-and-trap or headspace), the VOA vial's airtight seal never be broken prior to analysis.

X1.78 An additional source of inaccuracy in VOC analyses is their incomplete extraction from the sampled material (11-1612-17). This source of error can either be due to differences between sample preparation methods (that is, methanol extraction versus vapor partitioning) or the kinetics of the desorption processes. In general, as the indigenous total organic carbon content increases in a matrix, recoveries using vapor partitioning methods would be expected to decrease compared to methanol extraction, particularly for the more hydrophobic analytes (1617). Heat or sonication, or both, have been shown to speed up desorption processes (that is, mass transfer of analyte from the sampled matrix to the vapor phase or methanol); therefore, these more aggressive extraction steps should be considered when a total VOC concentration is needed. In some instances, incomplete extraction due to either the method used or the kinetics associated with the release of VOCs from a given matrix can result in an under estimation (perhaps as much as an order of magnitude) of the total VOC concentration present in a sample (11, 13, 15, 1612, 14, 16, 17).

X2. INFORMATION ON THE STORAGE PRESERVATION OF SAMPLES IN DISCRETE SAMPLERS AND COVERED CORE BARREL LINERS BY STORAGE UNDER LOW TEMPERATURE CONDITIONS

X2.1 The En Core sampler is a coring tool designed to collect, store, and transfer a discrete sample. Losses of VOCs due to biological degradation can be abated by storing samples at low temperatures, for VOC analysis. This sampler has three components: (1) a coring/storage chamber, which is volumetrically designed to collect either a 5-g or 25-g soil sample; (2) a vapor-tight plunger for the nondisruptive extrusion of the sample into an appropriate container example, in preparation for analysis; and (3) a press-on cap that has a vapor-tight seal and locking arm mechanism (see Fig. 4). The coring/storage chamber, plunger, and cap are constructed of an inert composite polymer. This device is certified as not having detectable levels of VOCs by the manufacturer and should not require cleaning, and field personnel don't have to handle chemical solutions or re-used. In addition, there are two stainless steel reusable handles that weigh samples. Moreover, freezing, rather than acidification, can be used to preserve VOCs in carbonaceous soils. An additional concern with the En Core sampler. One is designed for use during sample collection and acidification is that with some soil matrices, the other when extruding formation of acetone, a regulated compound itself, has been observed.

X2.2 Low temperatures that will freeze a soil sample in preparation for analysis. The manufacturer instructions should be followed when using the En Core sampler.

X2.2 Preliminary tests performed with the En Core sampler have demonstrated a freezer, by mixing table salt and ice together, or by using dry ice. It is recommended that this tool can prevent volatilization losses for up to six days when held at $4 \pm 2^\circ\text{C}$, and when stored at $-12 \pm 3^\circ\text{C}$ can prevent both losses due to biodegradation and volatilization these other temporary refrigerants, whenever possible. These other methods of achieving low temperatures that will freeze soil are intended for up short term use (1 to 14 days, 3 days), and perhaps longer. Although very promising, these initial results should not only be used to justify when the use of holding times longer than 48 h, unless it can following precautions are taken. When using salt and ice, this mixture should be demonstrated that contained in plastic bags, a longer storage time or different storage conditions, or both, do not influence high quality cooler should be used, and this refrigerant should be replaced when the concentration of the analyte(s) of interest in the matrix of concern or cooler temperature reaches -5°C . Use a thick walled Styrofoam cooler packed so that the data generated from analysis about two thirds of the samples meet the data quality objectives.

X2.3 Core barrel liners covered its volume is filled with either polytetrafluoroethylene or aluminum foil, are not recommended

for the storage bags containing a 1:3.6 weight ratio of samples intended NaCl to ice; initially establish a temperature of $-14 \pm 3^{\circ}\text{C}$, and keep below -5°C for VOC analysis because they do not have air-tight seals. Core barrel liners are inserts placed inside up to 20 h (18). However, a shorter period of refrigeration below -5°C would most likely have resulted if the cooler had been opened frequently for adding or hallow tube sampler (see Practice D 3550). When removing samples. If dry ice is used for storage, it should be placed below and above the sampled material exposed at the ends of these liners is often covered sample containers while not coming into direct contact with thin sheets of polytetrafluoroethylene or aluminum foil which are held in place with them. This can be accomplished by placing the sample containers inside a polyethylene cap cardboard box that is some times further wrapped (edges of cap and ends of then placed inside the sheet) cooler with a sealing tape. Core barrel liners, which are effective at maintaining dry ice packed around the sampled materials' structure often fail to retain VOCs sample box. This precaution is necessary because when these barriers are used dry ice comes into direct contact with some plastic materials it can cause them to cover the open ends (3). Sheets of polytetrafluoroethylene that are only 2 crack, or 3 mil (mil = 0.001 in.) thick are easily penetrated by VOC vapors. Elastic formulations of polytetrafluoroethylene (for example, white plumber's tape) show much greater rates of VOC penetration than non-elastic semi-translucent formulations. Aluminum foil fails because an airtight seal is often not achieved when this material is folded over may cause the end of seal on a core liner and it sometimes corrodes allowing small holes bottle to form. The addition of plastic caps fail because materials (that is, glass and plasetic) halve differengt contractile properties. The temperature inside a cooler packed with dry ice usually can not improve the performance of either polytetrafluoroethylene or aluminum foil; be measured with conventional thermometers, since pliable plastics sorb VOCs and sealing tapes it is often contain VOCs in their adhesive, which serves as a potential artifact source (3).

X2.4 Preliminary tests below -20°C . This extreme low temperature may affect the integrity of the seals of the sample container. There are also some special shipping concerns with both field and laboratory treated samples have confirmed the inadequacy use of these coverings to prevent significant VOC losses after only a few (two or four) days of storage at $4 \pm 2^{\circ}\text{C}$. In general, poorer performances were observed for aluminum foil two temporary refrigerants. For the salt and an elastic formulation of polytetrafluoroethylene as compared to a non-elastic formulation of polytetrafluoroethylene. Overall, it is expected ice mixture, the shipping period and conditions should be closely tracked so that the performance of core barrel liners to serve cooler temperature remains below -5°C . When dry ice is used as a storage chamber is subject to several variables, for example, refrigerant, a placard must be placed on the materials used to cover the ends, vapor pressure outside of the contaminant VOC(s), length of storage, cooler identifying the texture presence of the bulk material collected, this refrigerant and the method used to obtain and transfer subsamples. its weight.

X3. TESTING FOR CARBONATES

X3.1 Soil or waste samples may contain carbonates that will generate carbon dioxide gas (CO_2) when in contact with acid preservatives. The generation of CO_2 may drive off VOCs and cause sample containers to fail due to increased pressures within the container. To determine whether carbonates are present in waste and soil samples using an effervescence test: or soil, the following test should be performed.

X3.1.1 Moisten approximately 1 g of sample material that has been placed on a watch glass or similar surface with water, than stir to remove any trapped air.

X3.1.2 Add drop-wise a cold solution of 4N HCl to the moistened material while observing for effervescence using a hand lens. If effervescence (rapid formation of bubbles) is observed, then preservation by acidification is not appropriate. If effervescence is not observed samples can be preserved by acidification. To determine the amount of hydrochloric acid or sodium bisulfate required to give a pH of 2 or less add the prescribed (usually 5 g) amount of sample material to a vessel containing 5 mL of water, mix thoroughly, then slowly add one of these acids while monitoring that pH. The volume or weight of acid determined to be necessary to achieve a pH of 2 or less should then be added to vials containing 5 mL of water, prior to adding samples of similar materials.

REFERENCES

- (1) Minnich, M., Behavior and Determination of Volatile Organic Compounds in Soil: A Literature Review. EPA 600/R-93/140, National Exposure Research Laboratory, Las Vegas, NV, 1993.
- (2) Lewis, T. E., Crockett, A. B., Siegrist, R. L., and Zarrabi, K., Soil Sampling and Analysis for Volatile Organic Compounds, *Environmental Monitoring and Assessment*, 1994, 30: 213-246.
- (3) Hewitt, A. D., Lukash, N. J. E., Sampling for In-Vial Analysis of Volatile Organic Compounds in Soil, *Am. Environ. Lab* , 1996, 7: 15-19.
- (4) Siegrist, R. L., Jenssen, P. D., Evaluation of Sampling Method Effects on Volatile Organic Compounds Measurements in Contaminated Soils, *Environ. Sci. Technol.*, 1990, 24: 1387-1392.
- (5) Hewitt, A. D., Chemical Preservation of Volatile Organic Compounds in Soil, 1995, *Environ. Sci. Technol.*, 1995, 31, 67-70.
- (6) Urban, M. J., Smith, J. S., Schultz, E. K., Dickinson, R. K., Volatile Organic Analysis of a Soil Sediment or Waste Sample, Fifth Annual Waste Testing and Quality Assurance Symposium, U.S. Environmental Protection Agency, Washington, DC, 1989, II-87-II-101.
- (7) Ilias, A. M., Jeager, C., Evaluation of Sampling Techniques for the Analysis of Volatile and Total Recoverable Petroleum Hydrocarbons (TRPH) by IR, GC, and GC/MS Methods. In: Kostecky P. T., Calabrese E. J., Bonazountas M., *Eds*, *Hydrocarbon Contaminated Soils*, Vol 3, Chelsea, MI, Lewis Publishers, 1993, 3: 147-165.
- (8) Hewitt, A. D., Jenkins, T. F., Grant, C. L., Collection, Handling, and Storage: Keys to Improved Data Quality for Volatile Organic Compounds in Soil. *Am. Environ. Lab*, 1995, 7: 25-28.
- (9) Liikala, T. L., Olsen, K. B., Teel, S. S., Lanigan, D. C., Volatile Organic Compounds: Comparison of Two Sample Collection and Preservation Methods. *Environ. Sci. Technol.*, 1996, 30: 3441-7.
- (10) Smith, J. S., Enj, L., Comeau, J., Rose, C., Schulte, R. M., Barcelona, M. J., Kloop, K., Pilgrajm, M. J., Minnich, M., Feenstra, S., Urban, M. J., Moore, M. B., Maskarinec, M. P., Siegrist, R., Parr, J., and Claff, R. E., Volatile Organic Compounds in Soil: Accurate and Representative Analysis, 3152-4/96/0693, American Chemical Society, 1996, pp. 693-704.
- (11) Hewitt, A. D., Storage and Preservation of Soil Samples for Volatile Compound Analysis, USA Cold Regions Research and Engineering Laboratory, Special Report 99-5, 1999.
- (12) Sawhney, B. L., Pignatello, J. J., and Steinberg, S. M., Determination of 1,2 dibromoethane (EDB) in Field Soils: Implications for Volatile Organic Compounds, *J. Environ. Qual.*, 1998, 17: 149-52.
- (13) Hewitt, A. D., Miyares, P. H., Leggett, D. C., Jenkins, T. F., Comparison of Analytical Methods for Determination of Volatile Organic Compounds, *Environ. Sci. Technol.*, 1992, 26: 1932-8.
- (14) Askari, M. D. F., Maskarinec, M. P., Smith, S. M., Beam, P. M., and Travis, C. C., Effectiveness of Purge-and-trap for Measurement of Volatile Organic Compounds in Aged Soils, *Analytical Chemistry*, 1996, 68: 3431-3433.
- (15) Minnich, M. M., Zimmerman, J. H., and Schumacher, B. A., Extraction Methods for Recovery of Volatile Organic Compounds from Fortified, Dry Soils, *J. Assoc. Off. Anal. Chem.*, 1996, 79: 1198-1204.
- (16) Ball, W. P., Xia, G., Durfee, D. P., Wilson, R. D., Brown, M. J., and Mackay, D. M., Hot Methanol Extraction for the Analysis of Volatile Organic Chemicals in Subsurface Core Samples from Dover Air Force Base, Delaware, *Ground Water Monitoring and Remediation*, 1997, 17: 104-21.
- (17) Hewitt, A. D., Comparison of Sample Preparation Methods for the Analysis of Volatile Organic Compounds in Soil Samples: Solvent Extraction versus Vapor Partitioning, 1998, *Environ. Sci. Technol.* , 1998, 32: 143-9.
- (18) Hewitt, A. D., Frozen Storage of Soil Sample for Volatile Organic Compound Analysis, *Environmental Testing and Analysis* , Vol 8(5), 1999, pp. 18-25.
- (19) Sorini, S. S., Schabron, J. F., Rovani, J. F., Jr., En Core Sampler Performance: Storing Soil for VOC Analysis, *Soil and Sediment Contamination*, 2002, 11(1): pp. 19-40.

ASTM International takes no position respecting the validity of any patent rights asserted in connection with any item mentioned in this standard. Users of this standard are expressly advised that determination of the validity of any such patent rights, and the risk of infringement of such rights, are entirely their own responsibility.

This standard is subject to revision at any time by the responsible technical committee and must be reviewed every five years and if not revised, either reapproved or withdrawn. Your comments are invited either for revision of this standard or for additional standards and should be addressed to ASTM International Headquarters. Your comments will receive careful consideration at a meeting of the responsible technical committee, which you may attend. If you feel that your comments have not received a fair hearing you should make your views known to the ASTM Committee on Standards, at the address shown below.

This standard is copyrighted by ASTM International, 100 Barr Harbor Drive, PO Box C700, West Conshohocken, PA 19428-2959, United States. Individual reprints (single or multiple copies) of this standard may be obtained by contacting ASTM at the above address or at 610-832-9585 (phone), 610-832-9555 (fax), or service@astm.org (e-mail); or through the ASTM website (www.astm.org).